

APX9131

Hall Effect Micro Switch IC

Features

- Micro Power Operation for Battery Applications
- Chopper Stabilized Amplifier
- Independent of North or South Pole Magnet, Easy for Manufacture
- Small Size Package
- Lead Free Available (RoHS Compliant)

Applications

- Micro Switch
- Handheld Wireless Application Wake Up Switch
- Clamp Shell Type Application Switch
- Magnet Switch in Low Duty Cycle Applications

General Description

The APX9131 integrated circuit is an ultra-sensitive, pole independent Hall-effect switch with a latched digital output. 2.5 volt to 3.5 volt operation and a unique clocking scheme reduce the average operating power requirements. Either a north or south pole of sufficient flux will turn the output on; in the absence of a magnetic field, the output is off. The polarity independence and minimal power requirement allow this device to be easily replaced reed switch for superior for signal conditioning. Advanced CMOS processing is used to take advantage of low-voltage and low-power requirements, SOT-23 and TO-92 packages provide an optimized package for most applications.

Pin Description

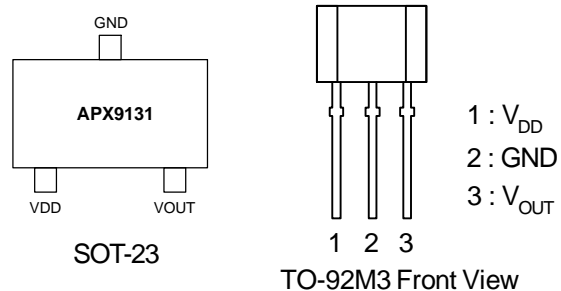

Ordering Information

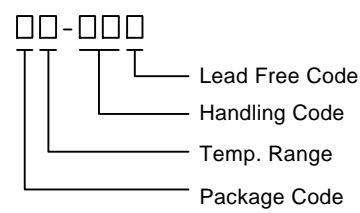
<p>APX9131</p> 	<p>Package Code A : SOT-23 AT : SOT-23 Thin E : TO-92M3 Operating Ambient Temp. Range I : -40 to 85°C Handling Code TR : Tape & Reel Lead Free Code L : Lead Free Device Blank : Original Device</p>
<p>APX9131 A/AT: X31X X: Date Code</p>	<p>APL9131 E: APX 9131 XXXXX XXXXX - Date Code</p>

Note: ANPEC lead-free products contain molding compounds/die attach materials and 100% matte tin plate termination finish; which are fully compliant with RoHS and compatible with both SnPb and lead-free soldering operations. ANPEC lead-free products meet or exceed the lead-free requirements of IPC/JEDEC J STD-020C for MSL classification at lead-free peak reflow temperature.

ANPEC reserves the right to make changes to improve reliability or manufacturability without notice, and advise customers to obtain the latest version of relevant information to verify before placing orders.

Function Pin Descriptions

No	Name	Function
1	V_{DD}	Power Input
2	V_{OUT}	When a magnetic field enters the hall element and exceeds the operate point B_{OPS} (or less than B_{OPN}) the output turns on (output is low). When the magnetic field is below the release point B_{RPS} (or above B_{RPN}), the output turns off (output is high). It is design with open drain configuration and connecting a pull up resistor from V_{OUT} to V_{DD} is necessary. It cannot be floating.
3	GND	Ground Connection

Block Diagram

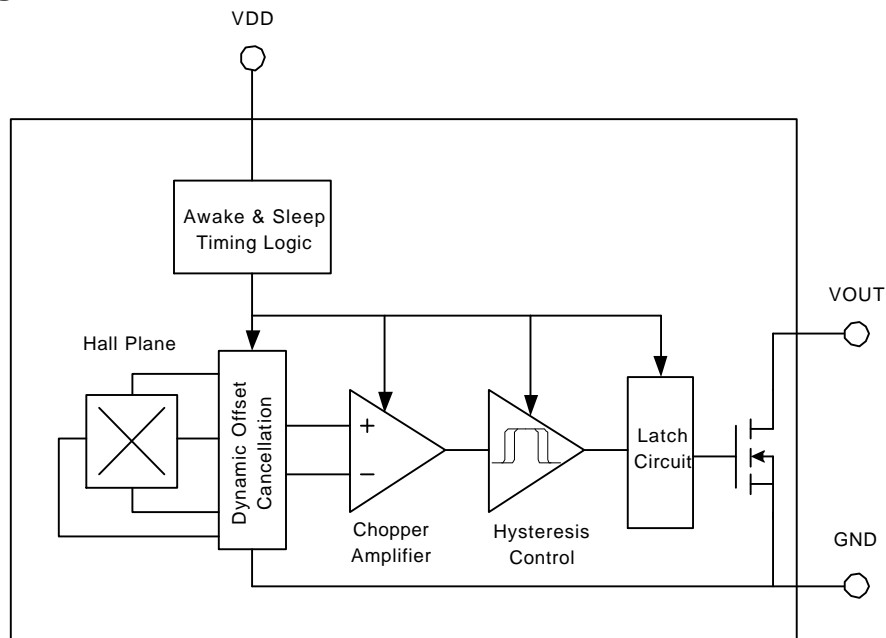

Typical Applications

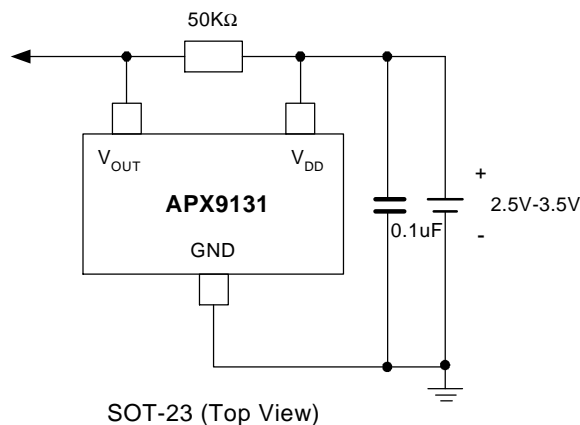

Absolute Maximum Ratings ($T_A = 25^\circ\text{C}$ unless otherwise noted)

Symbol	Parameter	Rating	Unit
V_{DD}	Supply Voltage	5	V
V_{OUT}	Output Voltage	5	V
T_J	Junction Temperature Range	150	°C
T_{STG}	Storage Temperature Range	-65 to +150	

Electrical Characteristics ($T_A = 25^\circ\text{C}$, $V_{DD}=3\text{V}$ unless otherwise noted)

Symbol	Characteristic	Test Condition	APX9131			Unit
			Min.	Typ.	Max.	
V_{DD}	Supply Voltage Range	Operating	2.5		3.5	V
I_{DD}	Supply Current	Average		5	10	μA
		Awake		1.2	2	mA
		sleep		2	8	μA
I_{OFF}	Output Leakage Current	$V_{OUT} = 3.5\text{V}$, $B_{RPN} < B < B_{RPS}$			1.0	μA
V_{OL}	Output Low Voltage	$I_{SINK} = 1\text{mA}$		20	40	mV
t_{awake}	Wake up Time			180		μs
t_{period}	Period			60		mS
d.c.	Duty Cycle			0.3		%
f_c	Chopping Frequency			11		KHz

Magnetic Characteristics ($T_A = 25^\circ\text{C}$, $V_{DD}=3\text{V}$ unless otherwise noted)

Symbol	Characteristic	Test Condition	APX9131			Unit
			Min.	Typ.	Max.	
B_{OPS}	Operate Points			50	75	G
B_{OPN}			-75	-50		G
B_{RPS}	Release Points		10	35		G
B_{RPN}				-35	-10	G
B_{hys}	Hysteresis			15		G

Typical Characteristics

Switching Points vs. Ambient Temperature

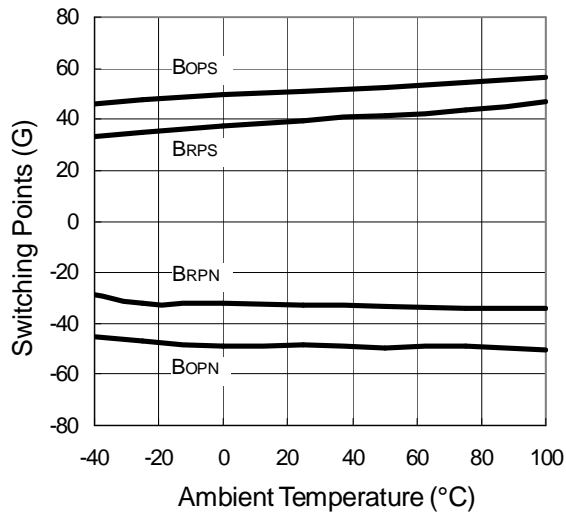

Switching Points vs. Supply Voltage

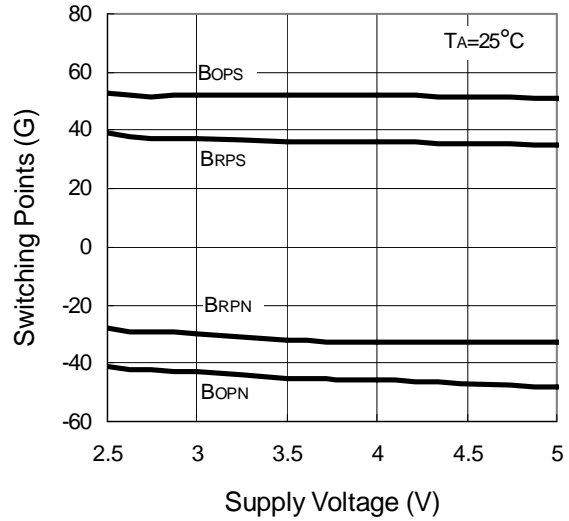

Average Supply Current vs. Ambient Temperature

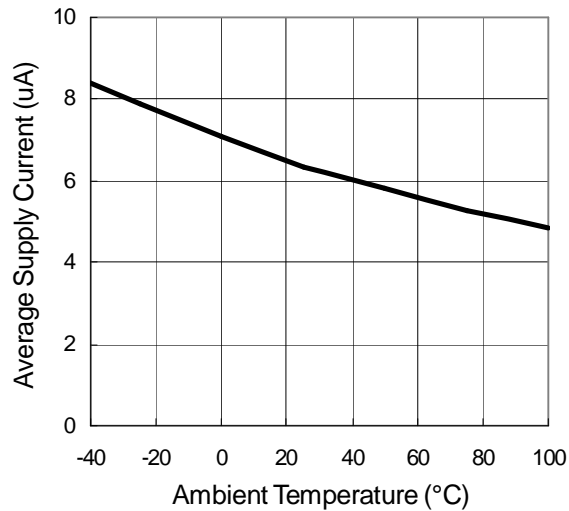

Average Supply Current vs. Supply Voltage

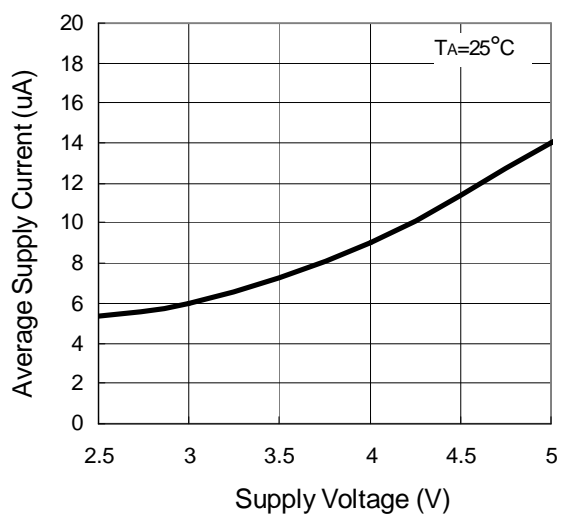

Typical Characteristics

Output Sink Current vs. Output Low Voltage

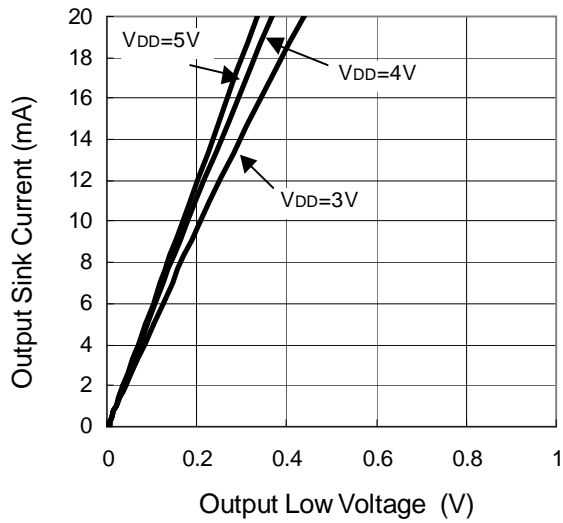

Output Switch Waveform

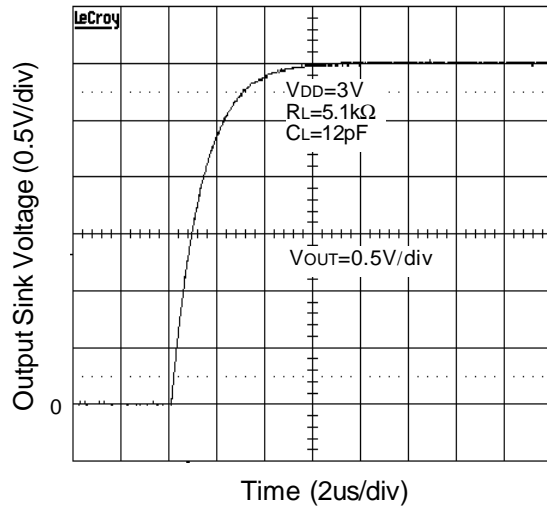

Output Switch Waveform

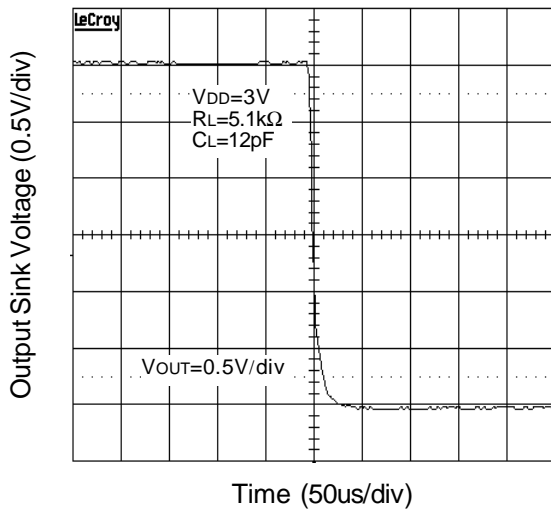

Function Description

Operation

The output of APX9131 switches low (turns on) when in presence of strong flux density facing the marked side of package exceeds the operate point B_{OPS} (or is less than B_{OPN}). After turn-on, the output is capable of sinking up to 1 mA and the output voltage is low (turns on). In absence of flux density below the release point B_{RPS} (or increased above B_{RPN}), the APX9131 output switches high (turns off). The difference in the magnetic operated and released point is the hysteresis (B_{hys}) of the device. This built-in hysteresis allows clean switching of the output even in the presence of external mechanical bouncing vibration and electrical noise.

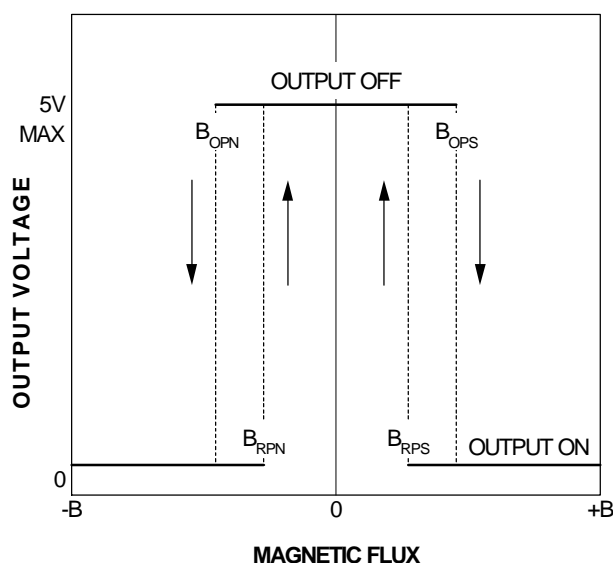

Application Information

It is strongly recommended that an external bypass capacitor be connected (in close to the Hall sensor) between the supply and ground of the device to reduce both external noise and noise generated by the chopper-stabilization technique. This is especially true due to the relatively high impedance of battery supplies. The output is an open drain output, it must be

Pole-independent

The pole-independent sensing technique allows for operation with either a north or south pole magnet orientation, enhancing the manufacturability of the device. The state-of-the-art technology provides the same output polarity for either pole in presence.

Awake & Sleep

Internal awake & sleep timing block circuit activates the sensor for 180 μ s and deactivates it for the remainder of the period (60 ms). A short "awake" time allows for stabilization prior to the sensor sampling and data latching on the falling edge of the timing pulse. While in sleep cycle the output is latched in its previous state.

Chopper Stabilized Technique

The chopper stabilized technique cancels the mismatching of the hall element, the amplifier offset voltage and temperature sensitive drift by the dynamic offset cancellation and switched capacitor technique. This technique produces devices have an extremely stable Hall output voltage, therefore the magnetic switch points are stable.

connected a pull-up resistor to a supply voltage which is lower than 5V, connect a 50k Ω resistor to VDD in common use.

Packaging Information

SOT-23

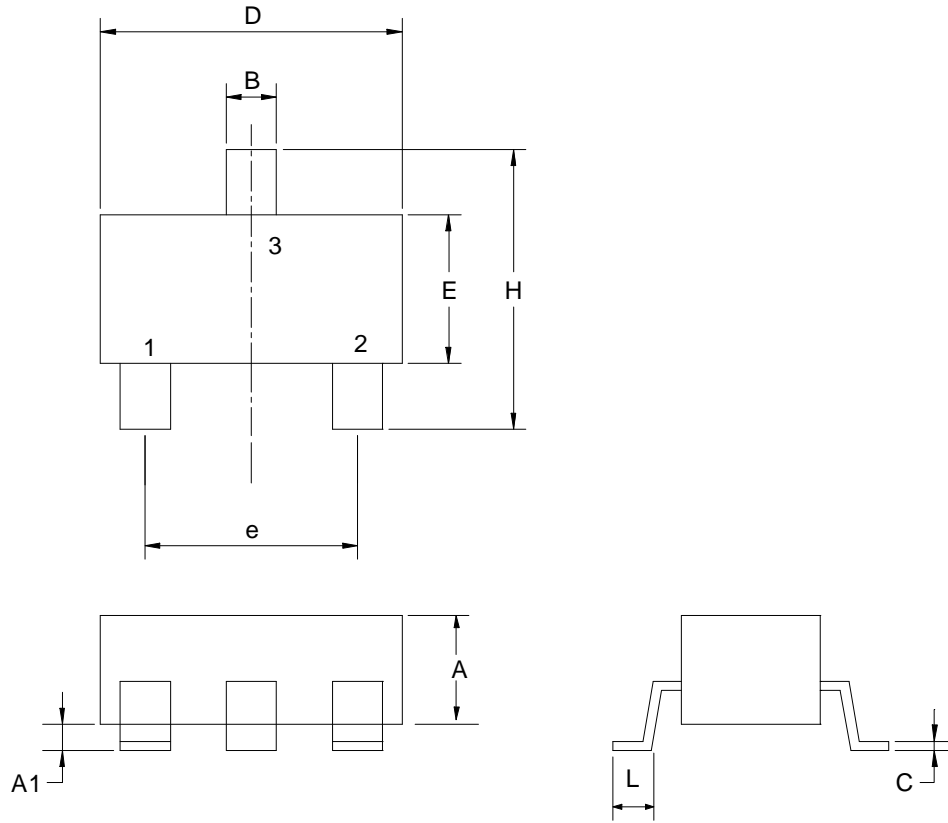

Dim	Millimeters		Inches	
	Min.	Max.	Min.	Max.
A	1.00	1.30	0.039	0.051
A1	0.00	0.10	0.000	0.004
B	0.35	0.51	0.014	0.020
C	0.10	0.25	0.004	0.010
D	2.70	3.10	0.106	0.122
E	1.40	1.80	0.055	0.071
e	1.90/2.1 BSC.		0.075/0.083 BSC.	
H	2.40	3.00	0.094	0.118
L	0.37		0.015	

Package Information

SOT-23Thin

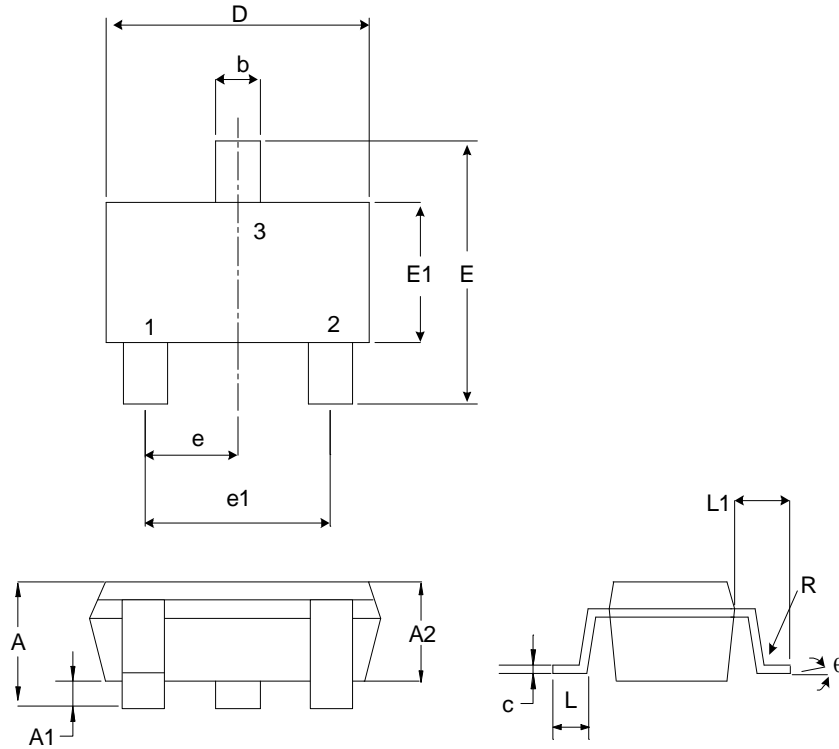

Dim	Millimeters		Inches	
	Min.	Max.	Min.	Max.
A	0.70	0.90	0.028	0.035
A1	0.00	0.10	0.000	0.004
A2	0.70	0.80	0.028	0.031
b	0.35	0.51	0.014	0.020
c	0.10	0.25	0.004	0.010
D	2.80	3.00	0.110	0.118
E	2.60	3.00	0.102	0.118
E1	1.50	1.70	0.059	0.067
e	0.95 BSC		0.0374 BSC	
e1	1.90 BSC		0.0748 BSC	
L	0.37	-	0.015	
L1	0.60 REF		0.0236 REF	
R	0.10	-	0.004	-
θ	0°	8°	0°	8°

Package Information

TO-92M3

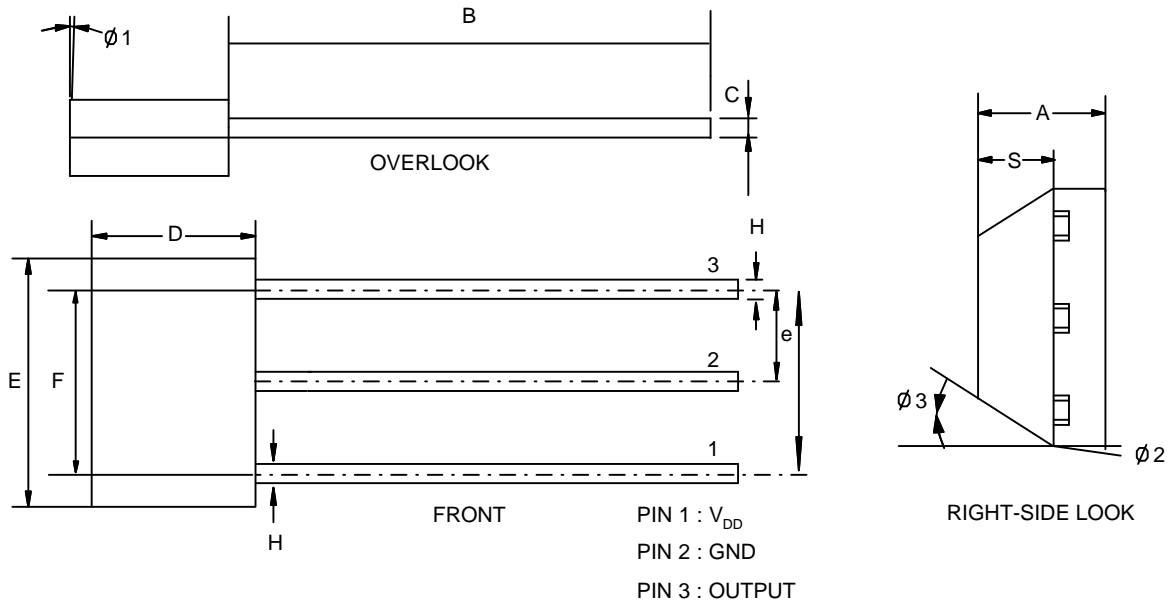

Dim	Millimeters		Inches	
	Min.	Max.	Min.	Max.
A	1.40	1.60	0.055	0.063
B	10	11	0.394	0.433
	14	15	0.551	0.591
C	0.35	0.41	0.014	0.016
D	2.80	3.20	0.110	0.126
e	1.24	1.30	0.049	0.051
E	3.90	4.30	0.154	0.169
F	2.34	2.64	0.092	0.104
G	4.04	4.24	0.159	0.167
H	0.35	0.41	0.014	0.016
I	2.51	2.57	0.099	0.101
S	0.63	0.81	0.025	0.032
$\phi 1$	5°		5°	
$\phi 2$	3°		3°	
$\phi 3$	45°		45°	

Physical Specifications

Terminal Material	Solder-Plated Copper (Solder Material : 90/10 or 63/37 SnPb), 100%Sn
Lead Solderability	Meets EIA Specification RSI86-91, ANSI/J-STD-002 Category 3.
Packaging	3000 devices per reel

Reflow Condition (IR/Convection or VPR Reflow)

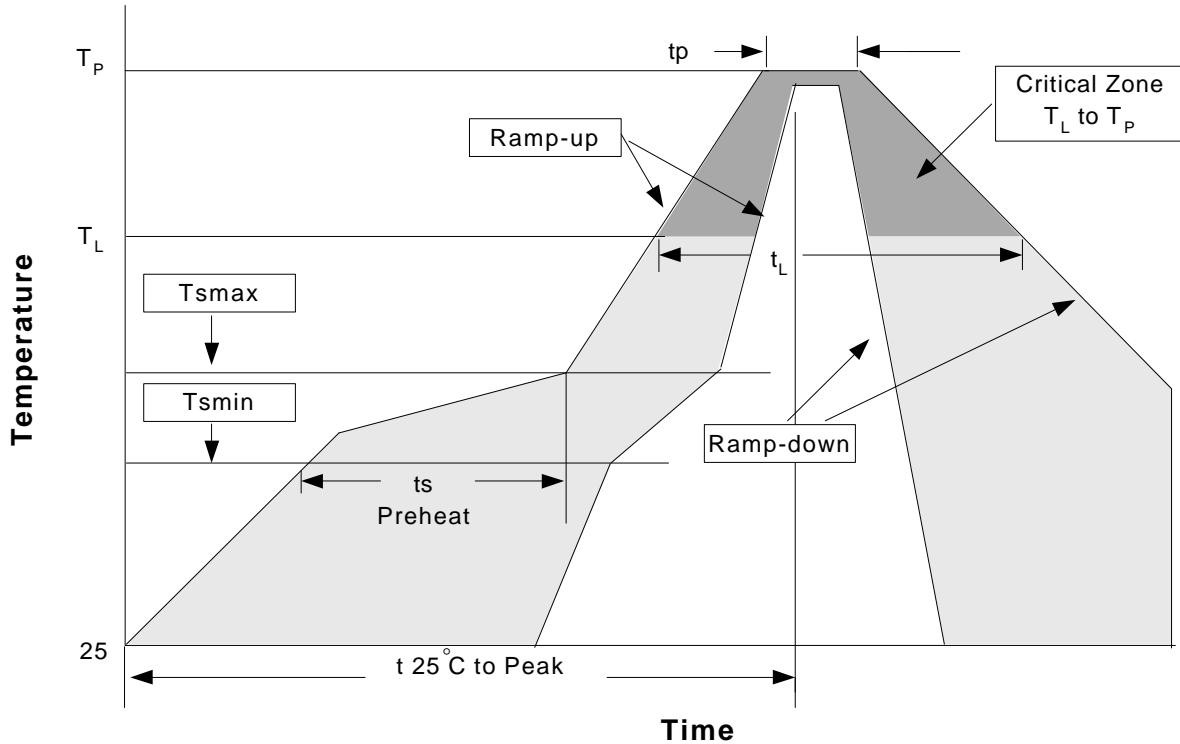

Classification Reflow Profiles

Profile Feature	Sn-Pb Eutectic Assembly	Pb-Free Assembly
Average ramp-up rate (T_L to T_P)	3°C/second max.	3°C/second max.
Preheat		
- Temperature Min (T_{smin})	100°C	150°C
- Temperature Max (T_{smax})	150°C	200°C
- Time (min to max) (t_s)	60-120 seconds	60-180 seconds
Time maintained above:		
- Temperature (T_L)	183°C	217°C
- Time (t_L)	60-150 seconds	60-150 seconds
Peak/Classification Temperature (T_p)	See table 1	See table 2
Time within 5°C of actual Peak Temperature (t_p)	10-30 seconds	20-40 seconds
Ramp-down Rate	6°C/second max.	6°C/second max.
Time 25°C to Peak Temperature	6 minutes max.	8 minutes max.

Note: All temperatures refer to topside of the package .Measured on the body surface.

Classification Reflow Profiles(Cont.)

Table 1. SnPb Eutectic Process – Package Peak Reflow Temperatures

Package Thickness	Volume mm ³ <350	Volume mm ³ ≥350
<2.5 mm	240 +0/-5°C	225 +0/-5°C
≥2.5 mm	225 +0/-5°C	225 +0/-5°C

Table 2. Pb-free Process – Package Classification Reflow Temperatures

Package Thickness	Volume mm ³ <350	Volume mm ³ 350-2000	Volume mm ³ >2000
<1.6 mm	260 +0°C*	260 +0°C*	260 +0°C*
1.6 mm – 2.5 mm	260 +0°C*	250 +0°C*	245 +0°C*
≥2.5 mm	250 +0°C*	245 +0°C*	245 +0°C*

*Tolerance: The device manufacturer/supplier **shall** assure process compatibility up to and including the stated classification temperature (this means Peak reflow temperature +0°C. For example 260°C+0°C) at the rated MSL level.

Reliability test program

Test item	Method	Description
SOLDERABILITY	MIL-STD-883D-2003	245°C , 5 SEC
HOLT	MIL-STD-883D-1005.7	1000 Hrs Bias @ 125 °C
PCT	JESD-22-B, A102	168 Hrs, 100 % RH , 121°C
TST	MIL-STD-883D-1011.9	-65°C ~ 150°C, 200 Cycles
ESD	MIL-STD-883D-3015.7	VHBM > 2KV, VMM > 200V
Latch-Up	JESD 78	10ms , I _{tr} > 100mA

Carrier Tape & Reel Dimensions

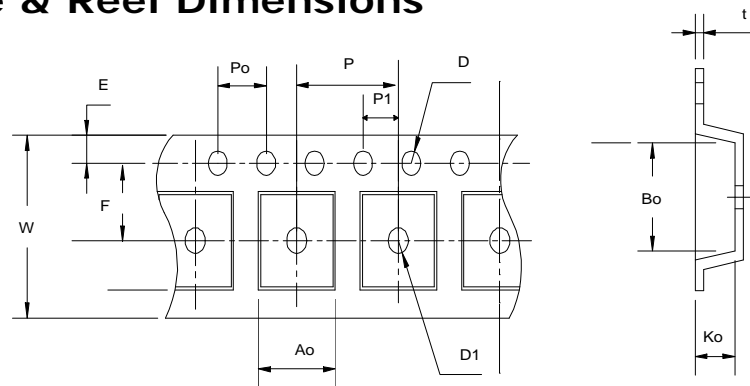

Carrier Tape & Reel Dimensions(Cont.)

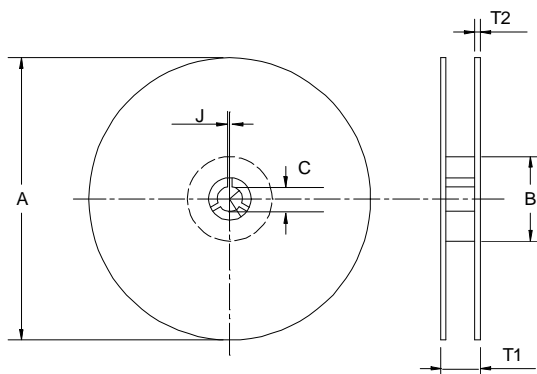

Application	A	B	C	J	T1	T2	W	P	E
SOT-23	178±1	60 ± 1.0	12.0	2.5 ± 0.15	9.0 ± 0.5	1.4	8.0+ 0.3 - 0.3	4.0	1.75
	F	D	D1	Po	P1	Ao	Bo	Ko	t
	3.5 ± 0.05	1.5 +0.1	0.1MIN	4.0	2.0 ± 0.05	3.1	3.0	1.3	0.2±0.03
Application	A	B	C	J	T1	T2	W	P	E
SOT-23 Thin	178±1	60 ± 1.0	12.0	2.5 ± 0.15	9.0 ± 0.5	1.4	8.0+ 0.2	4.0±0.1	1.75±0.1
	F	D	D1	Po	P1	Ao	Bo	Ko	t
	3.5 ± 0.05	φ1.55+ 0.05	φ 1.1±0.1	4.0±0.1	2.0 ± 0.05	3.3±0.1	3.2±0.1	1.1±0.1	0.25±0.05
Application	A0	A1	A2	A3	B0	B1	B2	C0	C1
TO-92	3.18~12	90±1	76±1	30±1	90±1	31±1	76±1	5.8	3.8
	C2	D	D1	D2	F1=F2	F1-F2	M	H	H1
	7.8	4.0±0.2	0.36~0.53	9.0 MAX	2.5+0.2 -0.1	±0.3	2.5±0.5	16±0.5	9±0.5
	H2	H2A	H3	H4	H5=H0+M	L	L1	P	P1
	0.5 MAX	0.5 MAX	27.0 MAX	20.0 MAX	18.5±0.5	11.0 MAX	2.5 MIN	12.7±0.3	6.35±0.4
	P2	T	T1	T2	T3	T4	W	W1	W2
	50.8±0.5	0.55 MAX	1.42 MAX	0.36~0.68	15	1.7	18.0±0.2	6.0±0.2	≤1

(mm)

Cover Tape Dimensions

Application	Carrier Width	Cover Tape Width	Devices Per Reel
SOT- 23	8	5.3	3000
SOT- 23 Thin	8	5.3	3000
TO-92	17.5~19	5.0~7.0	2000

(mm)

Customer Service

Anpec Electronics Corp.

Head Office :

No.6, Dusing 1st Road, SBIP,
Hsin-Chu, Taiwan, R.O.C.
Tel : 886-3-5642000
Fax : 886-3-5642050

Taipei Branch :

7F, No. 137, Lane 235, Pac Chiao Rd.,
Hsin Tien City, Taipei Hsien, Taiwan, R. O. C.
Tel : 886-2-89191368
Fax : 886-2-89191369

