

Three-Phase Full-wave Sine-wave Brushless Motor Driver

Features

- Three-Phase Full-Wave Sine-Wave Driver
- Sensor-Less driver control
- Rpm-Curve Control
- Rotation Direction Selectable
- Built-in 5V LDO Regulator
- Built-in Current Limit Circuit
- Built-in Over Current Protection
- Built-in Lock Protection and Auto Restart Function
- Soft Start Function
- FG, 1/2FG, 1/3FG or RD Output
- Built-in Thermal Shutdown Protection
- QFN4x4-24A Package
- Lead Free and Green Device Available (RoHS Compliant)
- PWM or SET or PWM+SET control OUT Duty
- Power Saving Function (PWM=0)
- Reset Signal Input

General Description

The APX9322A is a three-phase full-wave sine-wave brushless motor drive by sensor-less. This IC built-in linear or direct PWM input speed control, leading angle setting, current limit and soft start features suitable for the three-phase brushless DC motors. The APX9322A is available in QFN4x4-24A package(see Pin Configuration).

Pin Configuration

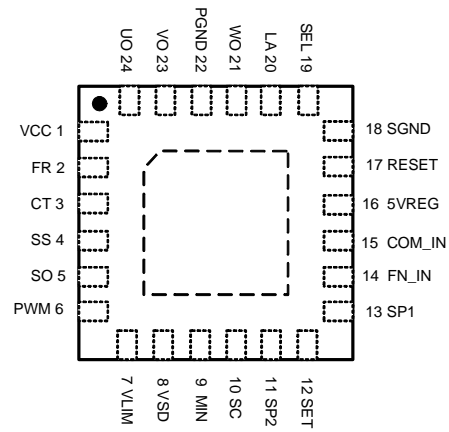



**QFN4x4-24A
Top View**

 =Thermal Pad (connected to the GND plane for better heat dissipation)

Applications

- Home Appliance Cooling Fan
- Instrumentation Fan

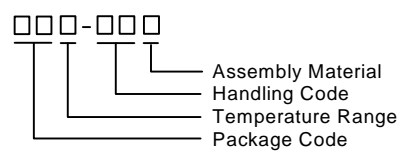
Ordering and Marking Information

<p>APX9322A □□□-□□□</p> <p style="margin-left: 40px;">  </p>	<p>Package Code QA : QFN4x4-24A</p> <p>Operating Ambient Temperature Range I : -40 to 105 °C</p> <p>Handling Code TR : Tape & Reel</p> <p>Assembly Material G: Halogen and Lead Free Device</p>
<p>APX9322A QA : </p>	<p>XXXXXX - Date Code</p>

Note1: ANPEC lead-free products contain molding compounds/die attach materials and 100% matte tin plate termination finish; which are fully compliant with RoHS. ANPEC lead-free products meet or exceed the lead-free requirements of IPC/JEDEC J-STD-020C for MSL classification at lead-free peak reflow temperature. ANPEC defines "Green" to mean lead-free (RoHS compliant) and halogen free (Br or Cl does not exceed 900ppm by weight inhomogeneous material and total of Br and Cl does not exceed 1500ppm by weight).

Absolute Maximum Ratings (Note 2)

Symbol	Parameter	Ratings	Unit
V _{CC}	VCC Pin Supply Voltage (VCC to SGND)	-0.3 to 20	V
I _{OUT}	UO, VO, WO Pin Maximum Output Peak Current	4	A
V _{UO} , V _{VO} , V _{WO}	UO, VO and WO Pins Output Voltage	VPGND-0.3 to VCC	V
V _{LA}	LA Pins Input Voltage (LA to SGND)	-0.3 to 7	V
V _{SET}	SET Pins Input Voltage (SET to SGND)	-0.3 to 7	V
I _{5VREG}	5VREG Pin Output Source Current	20	mA
V _{SP1}	SP1 Pin Input Voltage (SP1 to SGND)	-0.3 to 7	V
V _{SP2}	SP2 Pin Input Voltage (SP2 to SGND)	-0.3 to 7	V
V _{MIN}	MIN Pin Input Voltage (MIN to SGND)	-0.3 to 7	V
V _{VSD}	VSD Pin Input Voltage (VSD to SGND)	-0.3 to 7	V
V _{VLIM}	VLIM Pin input Voltage (VLIM to SGND)	-0.3 to 7	V
V _{SEL}	SEL Pins Input Voltage (SEL to SGND)	-0.3 to 7	V
V _{SO}	SO Pin Output Voltage	-0.3 to 20	V
I _{SO}	SO Pin Maximum Output Sink Current	10	mA
V _{PWM}	PWM Pin Input Voltage (PWM to SGND)	-0.3 to VCC	V
V _{FR}	FR Pin Input Voltage (FR to SGND)	-0.3 to 7	V
T _J	Maximum Junction Temperature	150	°C
T _{STG}	Storage Temperature	-65 to 150	°C
T _{SDR}	Maximum Lead Soldering Temperature, 10 Seconds	260	°C

Note 2: Absolute Maximum Ratings are those values beyond which the life of a device may be impaired. Exposure to absolute maximum rating conditions for extended periods may affect device reliability.

Thermal Characteristics

Symbol	Parameter	Typical Value	Unit
θ _{JA}	Thermal Resistance-Junction to Ambient (Note 3) QFN4x4-24A	50	°C/W
θ _{JC}	Thermal Resistance-Junction to Case (Note 4) QFN4x4-24A	20	°C/W
P _D	Power Dissipation, TA=25°C	2.5	W

Note 3: θ_{JA} is measured with the component mounted on a high effective thermal conductivity test board in free air. The exposed pad of QFN4x4-24A is soldered directly on the PCB.

Note 4: The case temperature is measured at the center on the top of the QFN4x4-24A package.

Recommended Operation Conditions (Note 5)

Symbol	Parameter	Range	Unit
V _{CC}	VCC Pin Supply Voltage Range	4.5 to 17	V
V _{LA}	LA Pins Input Voltage	0 to V _{5VREG}	V
V _{SET}	SET Pins Input Voltage	0 to V _{5VREG}	V
V _{SP1}	SP1 Pin Input Voltage	0 to V _{5VREG}	V
V _{SP2}	SP2 Pin Input Voltage	0 to V _{5VREG}	V
V _{MIN}	MIN Pin Input Voltage Range	0 to V _{5VREG}	V
V _{VSD}	VSD Pin Input Voltage	0 to V _{5VREG}	V
V _{VLM}	VLIM Pin Input Voltage	0 to V _{5VREG}	V
V _{FR}	FR Pin Input Voltage	0 to V _{5VREG}	V
V _{SEL}	SEL Pins Input Voltage	0 to V _{5VREG}	V
T _A	Ambient Temperature	-40 to 105	°C
T _J	Junction Temperature	-40 to 125	°C

Note 5: Refer to the typical application circuit

Electrical Characteristics (V_{CC}=12V, T_A= 25 °C. unless otherwise specified)

Symbol	Parameter	Test Conditions	APX9322A			Unit
			Min	Typ	Max	
SUPPLY CURRENT						
V _{5VREG}	5VREG Pin Output Voltage	I _{5VREG} = -10mA	4.8	5	5.2	V
I _{CC1}	Operating Current	Rotation Mode	3.5	5	6	mA
I _{CC2}	Operating Current	Lock Protection Mode	3.5	5	6	mA
I _{CC3}	Standby Supply Current	PWM=0	-	200	250	μA
OUTPUT DRIVERS						
V _{OL}	Low-side Output Saturation Voltage	V _{CC} =12V; I _{OUT} =400mA	-	45	75	mV
V _{OH}	High-side Output Saturation Voltage	V _{CC} =12V; I _{OUT} =400mA	-	70	105	mV
V _{SO}	SO Pin Low Voltage	I _{SO} =5mA	-	0.2	0.3	V
I _{SO}	SO Pin Off Leakage Current	V _{SO} =12V	-	0.2	1	μA
V _{ZC}	Output BEMF ZC Hysteresis		-	±100	-	mV
DO _{MIN}	Minimum Output Duty		10	-	-	%
LOCK PROTECTION						
V _{CTH}	CT Pin High Level Voltage		2.7	3	3.2	V
V _{CTL}	CT Pin Low Level Voltage		0.8	1	1.2	V
I _{CT1}	CT Charge Current	V _{CT} =0.7 V	1.5	2	2.5	μA
I _{CT2}	CT Discharge Current	V _{CT} =3.5V	0.15	0.2	0.25	μA
R _{CT}	CT Charge/Discharge Current Ratio		8	10	12	-
START UP OSCILLATOR						
V _{SCH}	SC Pin High Level Voltage		1	1.2	1.4	V
V _{SCL}	SC Pin Low Level Voltage		0.5	0.6	0.7	V
I _{SC1}	SC Pin Charge Current	V _{SC} =0V	20	40	50	μA
I _{SC2}	SC Pin Discharge Current	V _{SC} =2V	30	45	60	μA

Electrical Characteristics (Cont.) ($V_{CC}=12V$, $T_A=25\text{ }^\circ\text{C}$. unless otherwise specified)

Symbol	Parameter	Test Conditions	APX9322A			Unit
			Min	Typ	Max	
SOFT START OSCILLATOR						
V_{SSH}	SS Pin High Level Voltage		1	1.2	1.4	V
V_{SSL}	SS Pin Low Level Voltage		0.5	0.6	0.7	V
I_{SS1}	SS Pin Charge Current	$V_{SS}=0V$	6	10	14	μA
I_{SS2}	SS Pin Discharge Current	$V_{SS}=2V$	6	10	14	μA
FR						
V_{FRH}	FR Pin High Level Voltage		2.5	-	V_{5VREG}	V
V_{FRL}	FR Pin Low Level Voltage		0	-	1	V
I_{FR}	FR Pin Bias Current	$V_{FR}=0V$	0.6	1.2	1.8	μA
PWM MODE						
V_{PVMH}	High Level Voltage for PWM Mode		2.5	-	5.5	V
V_{PVML}	Low Level Voltage for PWM Mode		0	-	1	V
I_{PWM}	PWM Pin Bias Current	$V_{PWM}=0V$	-	20	40	μA
F_{PWM}	PWM Input Frequency		1	-	50	kHz
F_{OUT}	Output Switch Frequency		26	28	30	kHz
CURRENT PROTECTION						
I_{LIM}	Current Limit Level	$V_{LIM}=0\sim 1V$	-	0	-	A
	Current Limit Level	$V_{LIM}=2.5V$	-	1.75	-	A
	Current Limit Level	$V_{LIM}=4\sim 4.5V$	-	3.5	-	A
	Current Limit Level	$V_{LIM}=4.5V\text{ to }V_{5VREG}$	-	2.3	-	A
I_{OCP}	Over Current Protection		-	3.6	-	A
THERMAL PROTECTION						
	Thermal Protection Temperature		-	165	-	$^\circ\text{C}$
	Thermal Protection Hysteresis		-	30	-	$^\circ\text{C}$

Typical Operating Characteristics

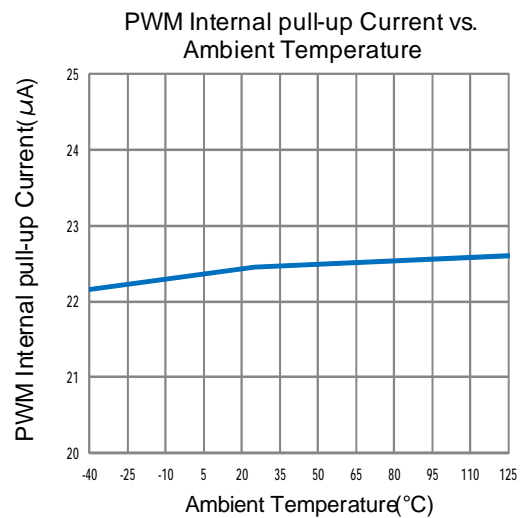
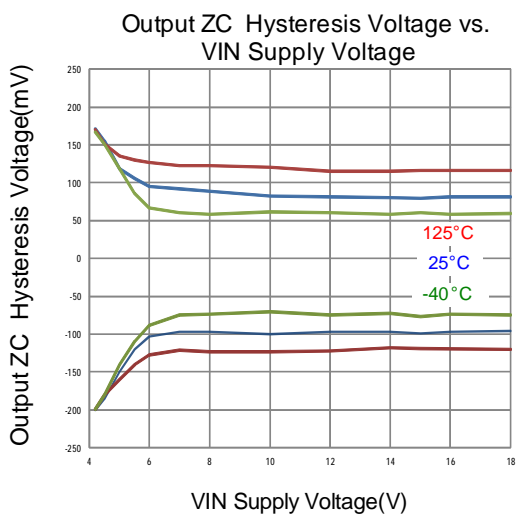
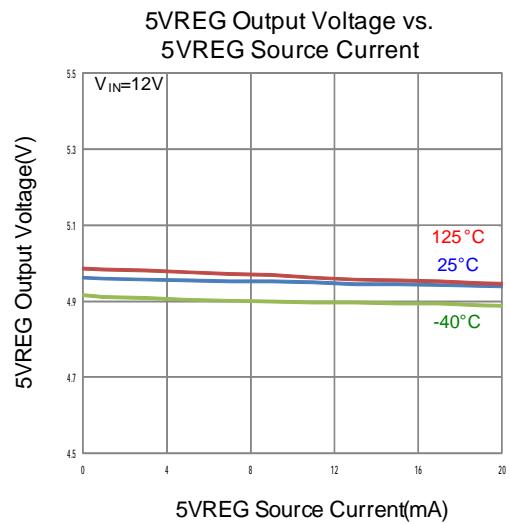
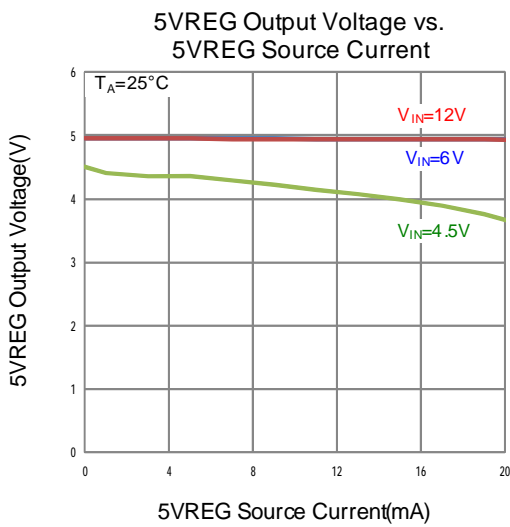
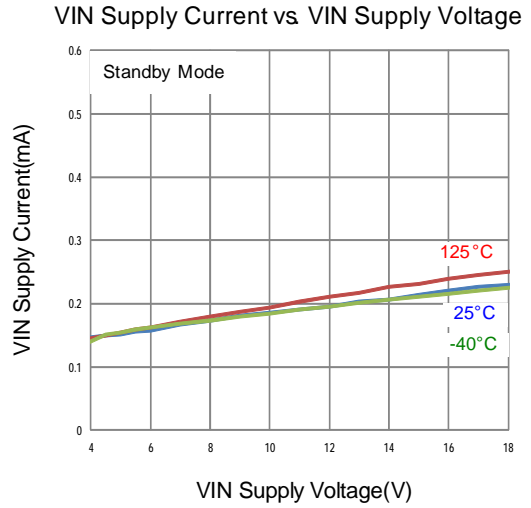
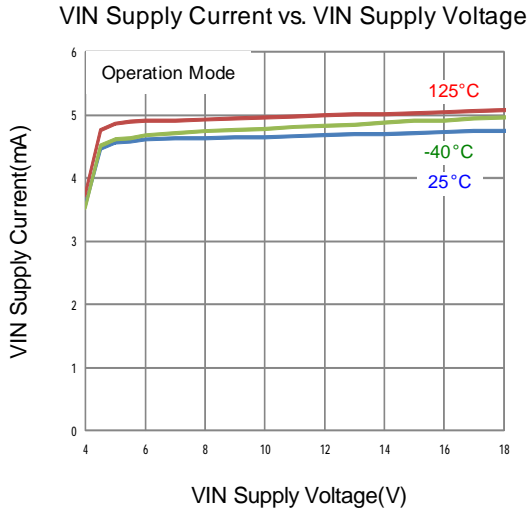

Typical Operating Characteristics (Cont.)

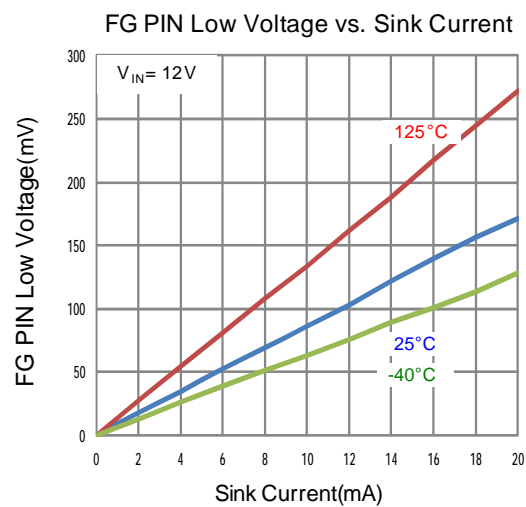
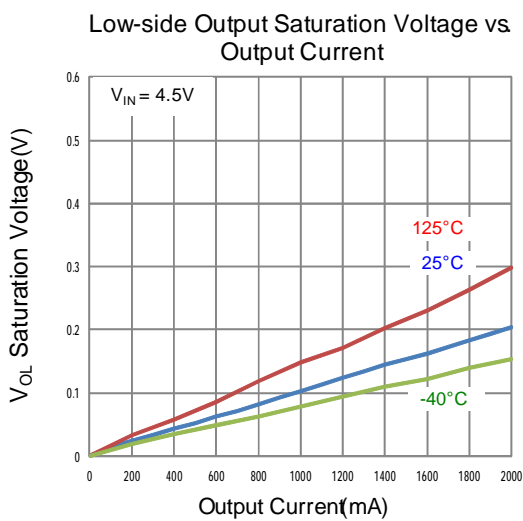
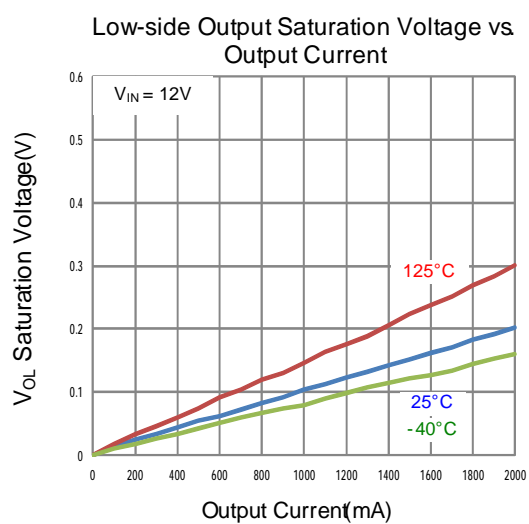
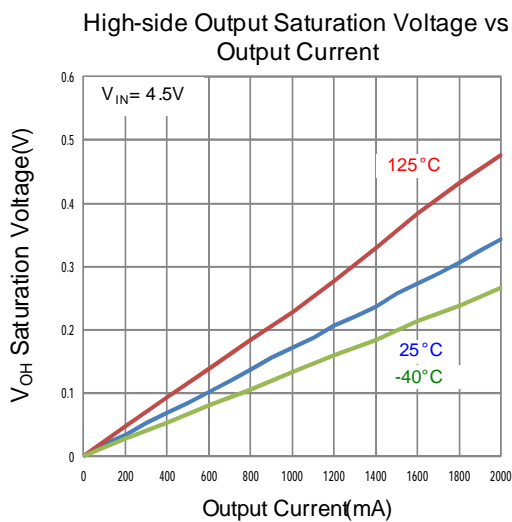
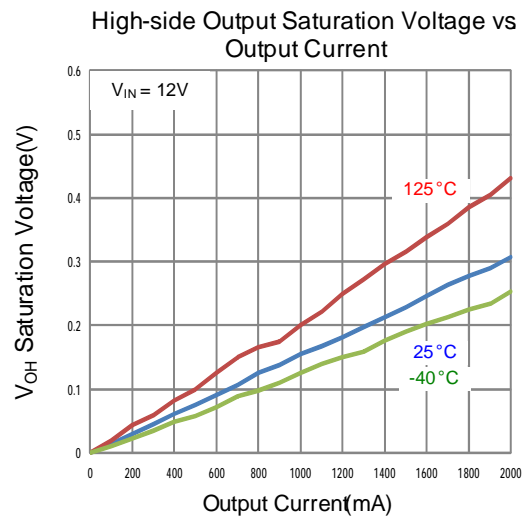
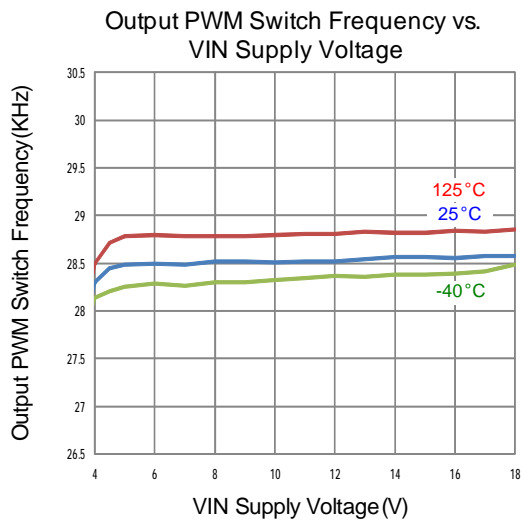

Typical Operating Characteristics (Cont.)

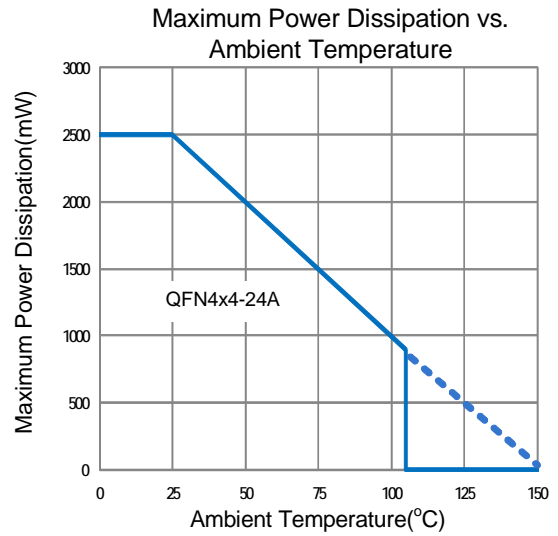
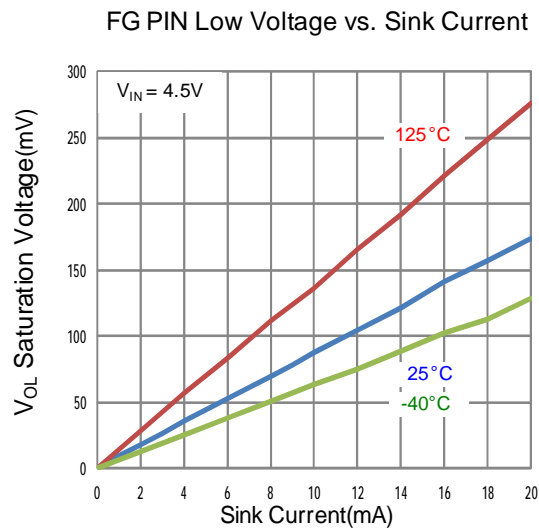

Pin Description

PIN		FUNCTION
NO.	NAME	
1	VCC	Supply Voltage Input Pin.
2	FR	Rotation Direction Control. Low Level Input (short to GND): U → W → V (Reverse) High Level Input (short to 5VREG or floating): U → V → W (Forward)
3	CT	Shutdown Time and Restart Time Setting. Connect a capacitor to SGND to set shutdown time and restart time in lock mode.
4	SS	Soft-Start Time Setting. Connect a capacitor to SGND to set soft-start time to reduce the large current at power on and lock-restart mode.
5	SO	Rotation Speed Output or Rotation Detection Output. This is an open-drain output.
6	PWM	PWM Signal Input Terminal. Please let it be floating when not be used.
7	VLIM	Current Limit Setting Input Pin.
8	VSD	Shutdown PWM Duty Setting. Use a voltage divider from 5VREG to set VSD pin voltage for setting Shutdown PWM Duty.
9	MIN	Minimum Speed Setting. Use a voltage divider from 5VREG to set MIN pin voltage for setting minimum speed.
10	SC	Start-up Time Setting Input Pin. Connect a capacitor to SGND to set the start-up timing.
11	SP2	Maximum Speed Setting. Use a voltage divider from 5VREG to set MIN pin voltage for setting maximum speed.
12	SET	Speed Setting. External voltage into SET pin to set fan speed.
13	SP1	Minimum PWM Duty Setting. Use a voltage divider from 5VREG to set SP1 pin voltage for setting minimum PWM Duty.
14	FN_IN	Internal Motor Floating Terminal Voltage Output Pin. Connect a capacitor to COM_IN to filter.
15	COM_IN	Internal Motor Neutral Point Input Pin. Connect a capacitor to FN_IN to filter.
16	5VREG	5V Regulator Output. This is a 5V constant-voltage output for application circuit biases.
17	RESET	Reset Signal Input.
18	SGND	Control Stage GND.
19	SEL	FG · RD or Modulation Shift Mode Setting. Use a voltage divider from 5VREG to set SEL pin voltage for setting.
20	LA	Input terminal for setting lead angle. Use a voltage divider from 5VREG to set VLA pin voltage for the lead angle setting.
21	WO	Driver Output Pin. Output signal for driving motor phase W.
22	PGND	Power Stage GND.
23	VO	Driver Output Pin. Output signal for driving motor phase V.
24	UO	Driver Output Pin. Output signal for driving motor phase U.

Block Diagram

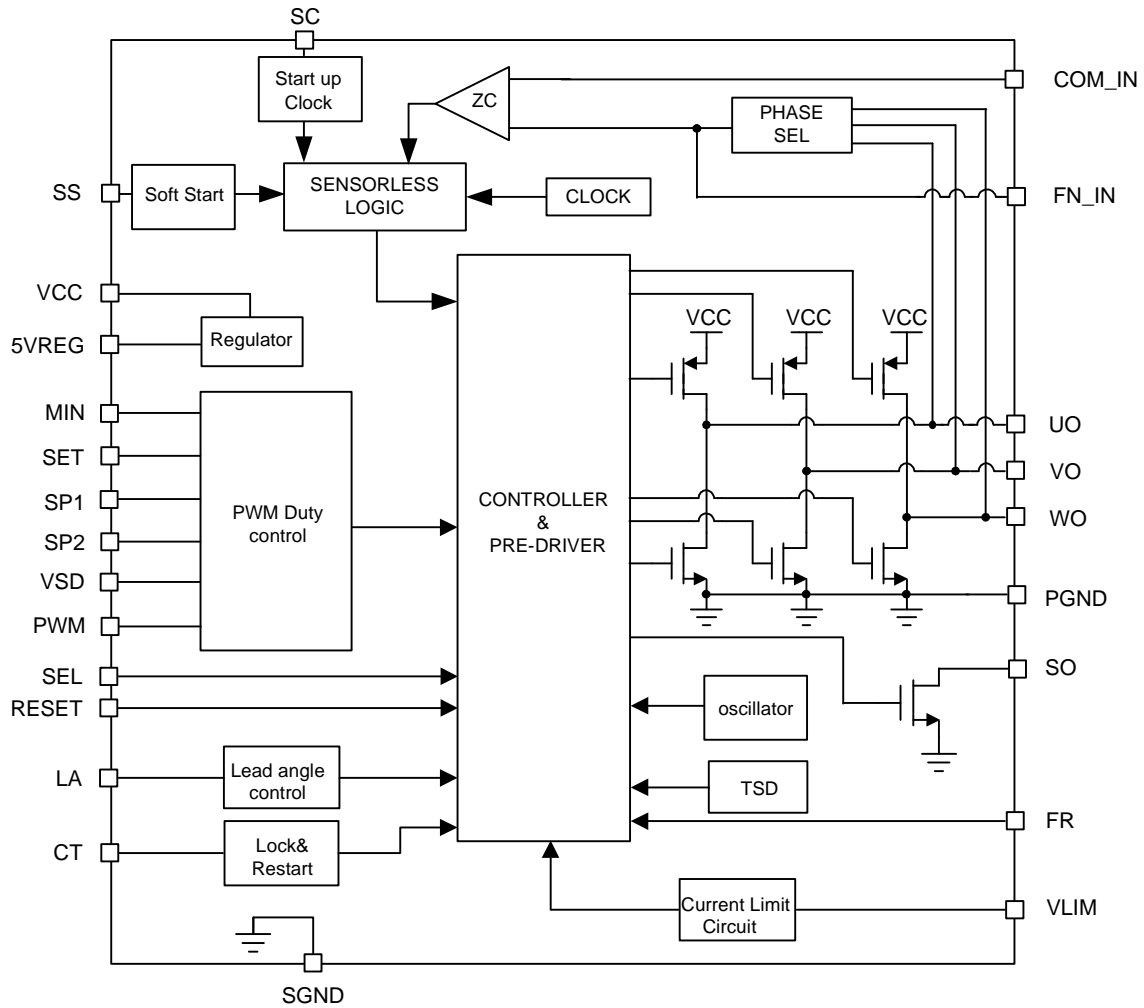

Typical Application Circuit

Circuit 1: PWM Speed Control

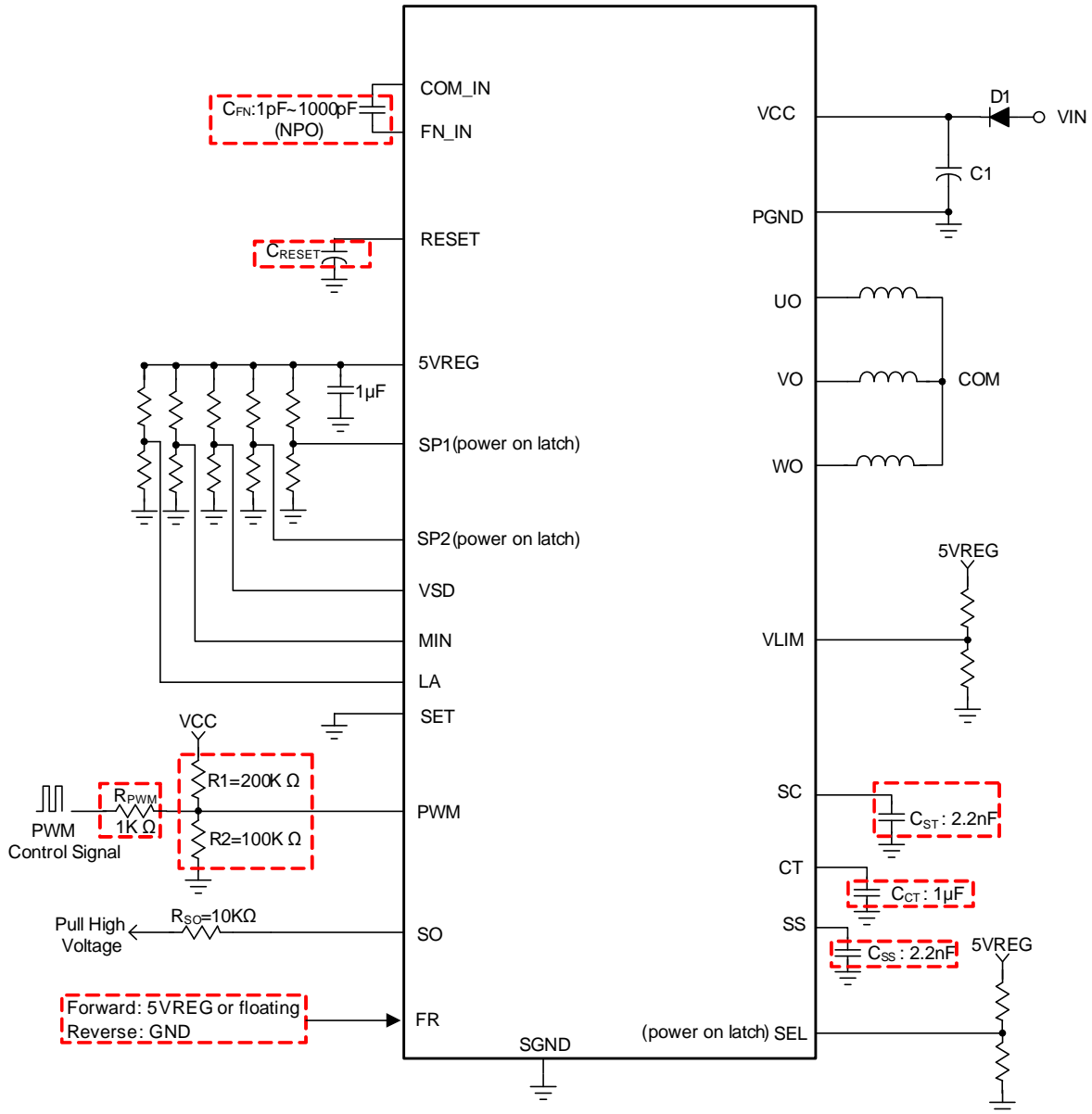

Note: 1. The capacitance of C_{FN} , C_{RESET} , C_{SS} , C_{ST} and C_{CT} can be fine tune for different parameter of motor .

2. R_{PWM} is optional to protect internal circuit for abnormal voltage stress.
3. FR prohibited changing the level when fan operation.
4. COM_IN and FN_IN are internal neutral point pin, not allow connect any voltage.
5. R1 and R2 are option for PWM drive capability

Typical Application Circuit

Circuit 2: SET Voltage Input Speed Control

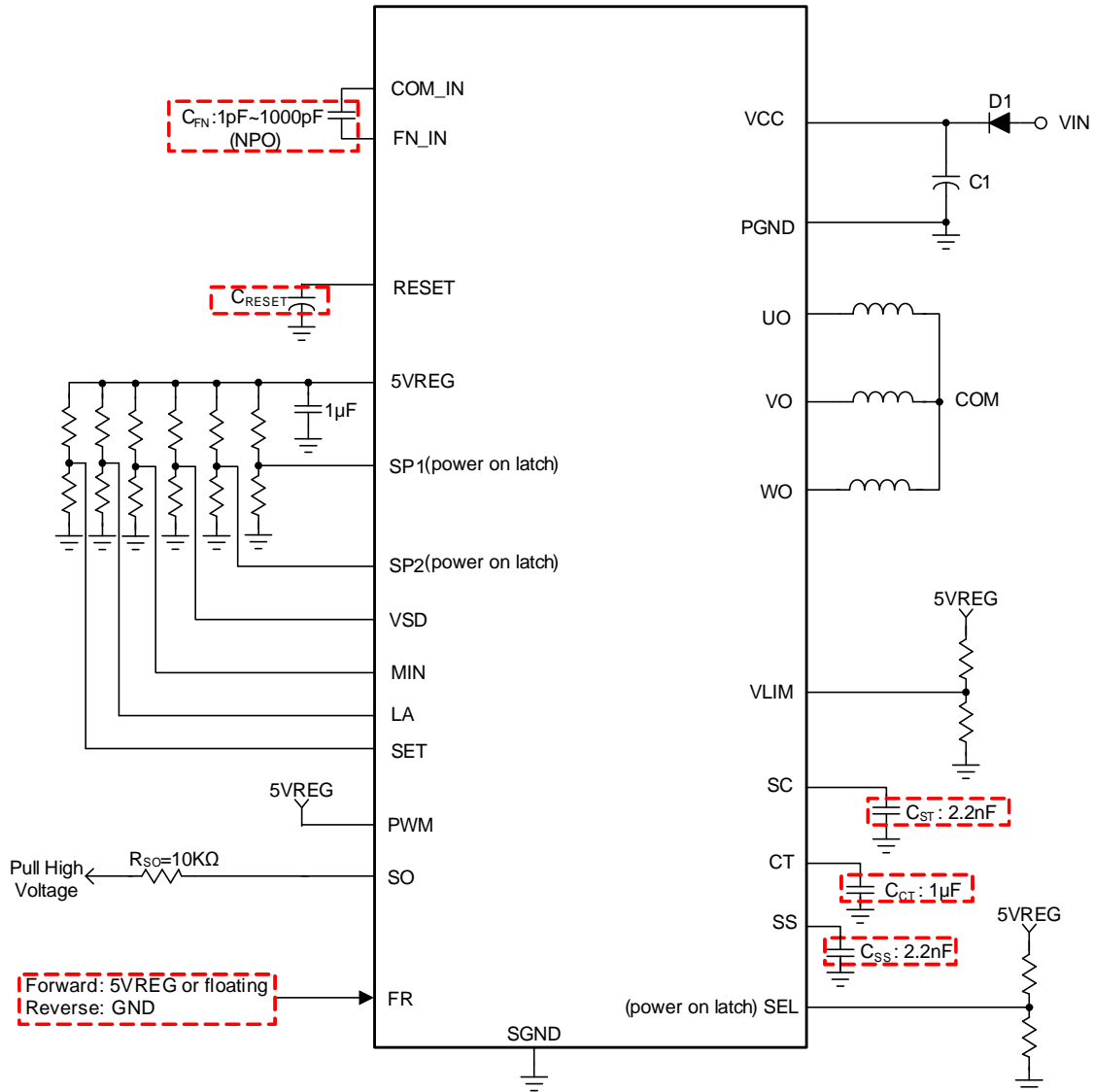

- Note: 1. The capacitance of C_{FN} , C_{RESET} , C_{SS} , C_{ST} and C_{CT} can be fine tune for different parameter of motor .
 2. FR prohibited changing the level when fan operation.
 3. COM_IN and FN_IN are internal neutral point pin, not allow connect any voltage.

Function Descriptions

Rpm-Curve Control

The APX9322A has four input pin SP1, SP2, VSD and MIN to control output duty of driver for the rotation speed of motor. The minimum output duty need larger than 10%.

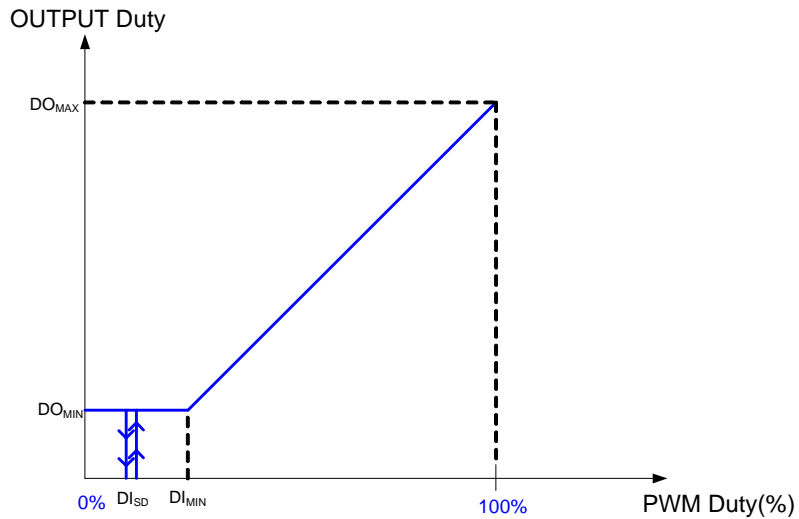

Figure1: Output Duty Control

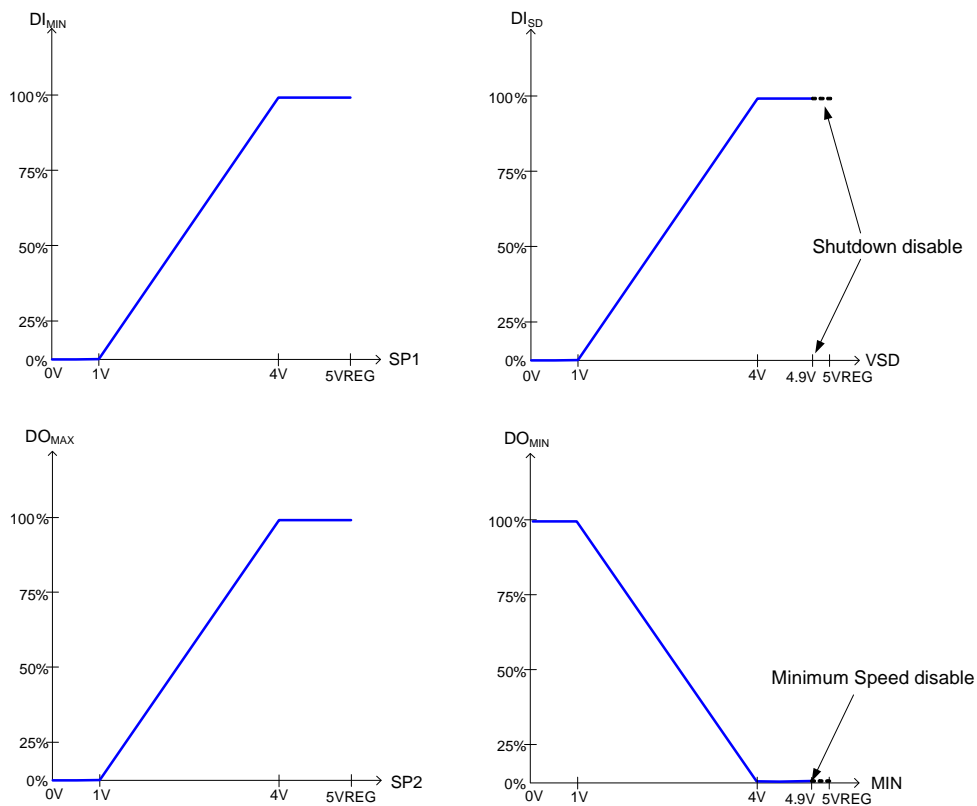

Figure 2: DI_{MIN} , DI_{SD} , DO_{MAX} , and DO_{MIN} need SP1, VSD, SP2, and MIN to control

Function Descriptions (Cont.)

PWM or SET Control or PWM+SET

The APX9322A also support direct PWM input signal or SET input voltage or PWM+SET speed control. When the MIN pin pulled up to V_{5VREG} , the PWM or SET input pin to control the output duty directly.

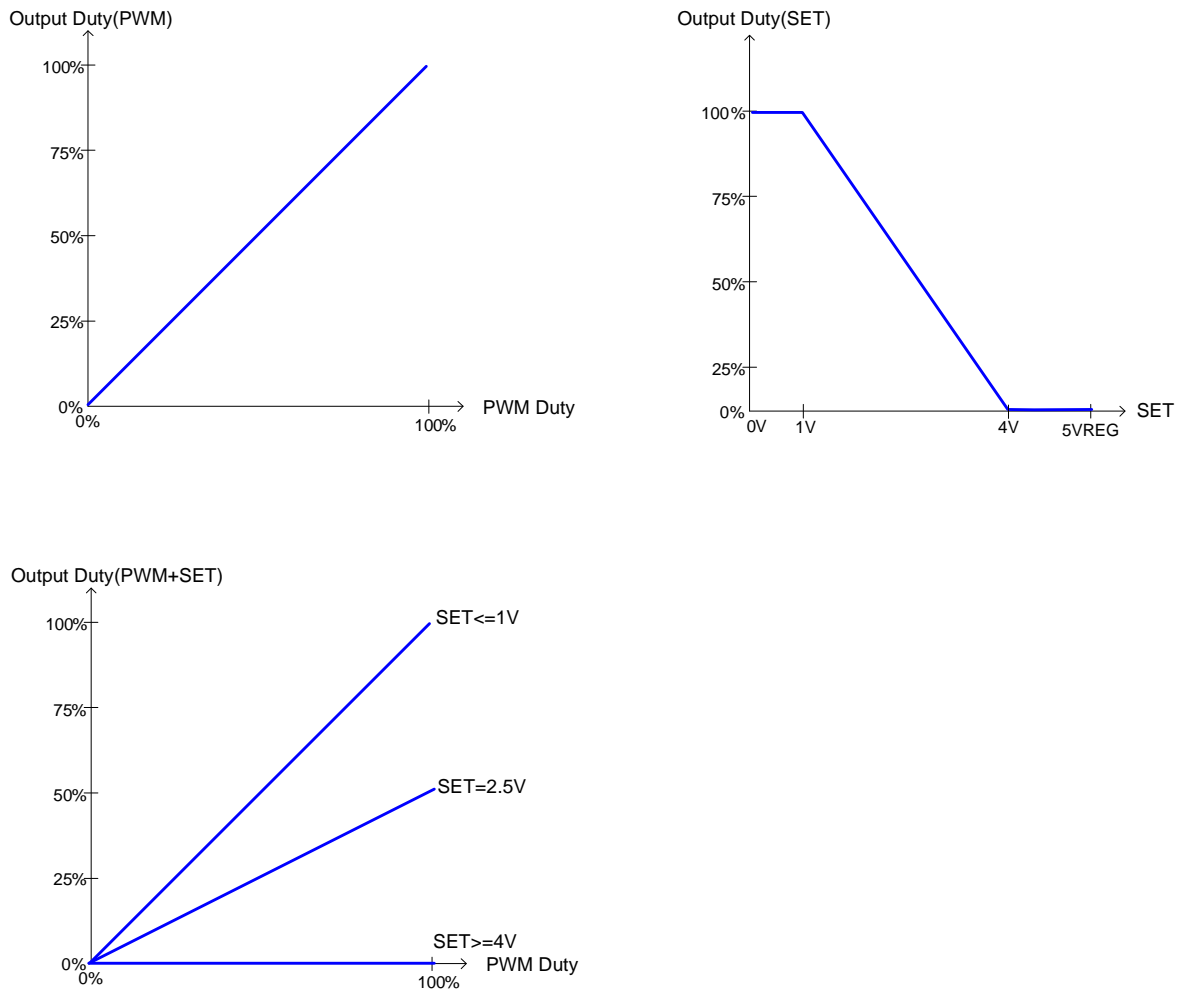

Figure3: Direct PWM Mode or SET Mode or PWM+SET Mode Output Duty Control

Function Descriptions (Cont.)

Lead Angle Control

The APX9322A built in automatic lead angle controlled by the duty variation of PWM. The maximum lead angle can be adjusted between 0° to 58° in 32 separate steps according to the input voltage of LA pin, which works with 0V to V_{5VREG} . The lead angle control range is 0° to the maximum value set by LA input for PWM duty 0% to 100%.

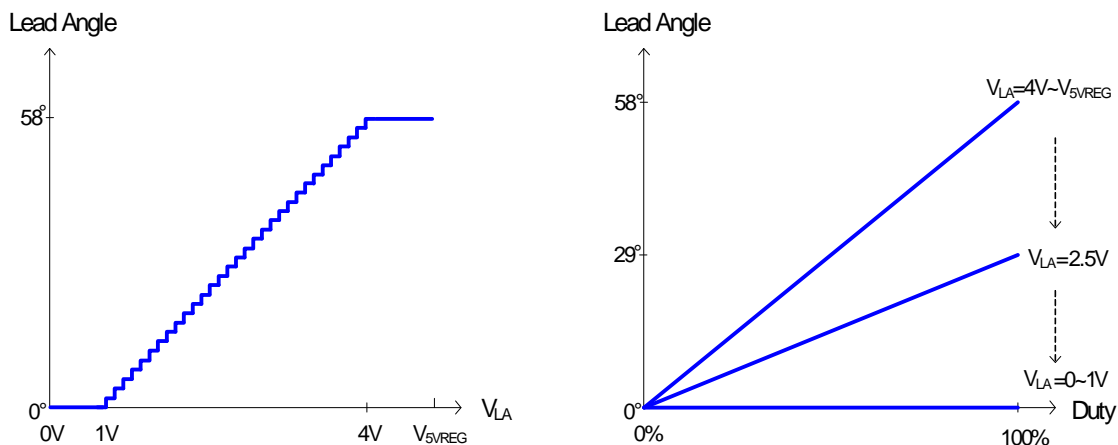

Figure4: Lead Angle Control

SEL Control

The APX9322A also support FG, 1/2FG, 1/3FG or RD Output.

SEL Pin Input Voltage	SO Output	Modulation pattern
0V~1.6V	FG	shift pattern
1.6V~2.2V	RD	shift pattern
2.2V~2.8V	1/2FG	shift pattern
2.8V~3.4V	1/3FG	shift pattern
3.4V~5V	FG	original pattern

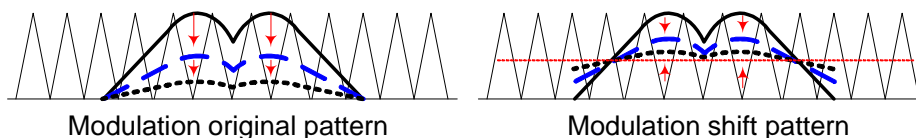

Table 1: SEL Pin Definition

Function Descriptions (Cont.)

Sine Wave Modulation

This is a soft switch PWM output to make the phase current smoother, which can reduce the noise of motor in switch interval. Using PWM duty control to simulate the idea sine wave output current.

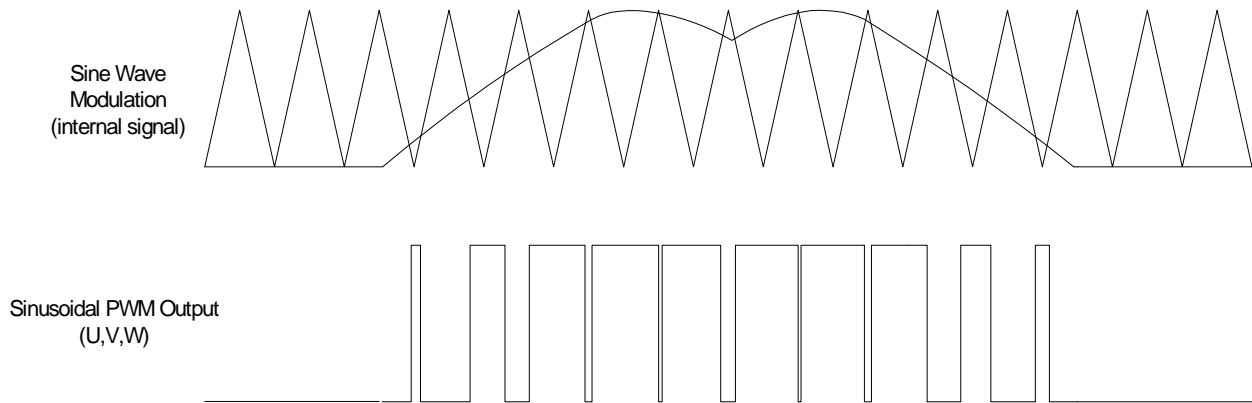

Figure 5: Sine Wave Modulation PWM Output

Function Descriptions (Cont.)

Lock Protection and Auto Restart

The APX9322A provides the lockup protection and automatic restart functions for preventing the coil burnout while the fan motor is locked. Connecting the capacitor from CT pin to SGND can determine the shut down time and restart time.

Current Limit and Over Current Protection (OCP)

The APX9322A includes an internal current sense circuits for current limit and over-current protection (OCP). When the total current of three phase over the current limit level, the high side driver will be turned off to stop supplying current to the motor. If the total output current over the OCP current level, the OCP function will be enable to turn-off all of the output driver to prevent output short through condition until pull low PWM pin or re-power on or wait 2 seconds.

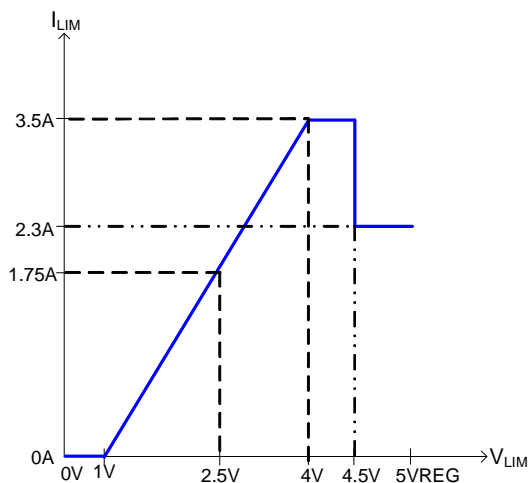

Figure 6: Current Limit Control

Thermal Protection

The APX9322A is designed with a thermal protection to protect the IC from the damage of over temperature. When internal junction temperature reaches 165°C, the output devices will be switched off. When the IC's junction temperature cools by 30°C, the thermal sensor will turn the output devices on again resulting in a pulsed output during continuous thermal overload.

Application Information

Input Protection Diode & Capacitor

The IC should be added a protection diode (D1) to prevent the damage from the power reverse connection. However, the protection diode will cause a voltage drop on the supply voltage. The current rating of the diode must be greater than the maximum output current. For the noise reduction purpose, a capacitor (C1) must connect between VCC and GND. It is the suggestion that C1 should be placed as close as possible to the device VCC pin.

SC Capacitor

The SC pin capacitor is used to set the force start up timing (T_{SC}) for sine-wave start up. Adjust the SC capacitor can set the start up timing for different motor or loading of fan motor. T_{SC} would increase in proportion to the capacitor.

EX:

$$T_{SC} = \frac{2 \times (V_{SCH} - V_{SCL}) \times C_{SC}}{I_{SC}} \times 80 \times 32$$

For example:

$$C_{SC} = 1.0nF$$

$$V_{SCL} = 0.6V, V_{SCH} = 1.2V, I_{SC} = (I_{SC1} + I_{SC2})/2 = 42.5\mu A$$

The force start up time is 72.28ms

$$\begin{array}{l} : \\ C_{SC} = 1.0nF \gggg T_{SC} = 72.28ms \\ C_{SC} = 2.2nF \gggg T_{SC} = 159.021ms \\ : \\ C_{SC} = 5nF \gggg T_{SC} = 361.41ms \\ : \end{array}$$

Application Information

SS Capacitor

The SS capacitor is used to set the output duty change rate for soft start. The time (T_{SS}) is define the time of output duty from 0% to 100%. T_{SS} would increase in proportion to the capacitor.

EX:

$$T_{SS} = \frac{2 \times (V_{SSH} - V_{SSL}) \times C_{SS}}{I_{SS}} \times 64 \times 512$$

For example:

$$C_{SS} = 1\text{nF}$$

$$V_{SSL} = 0.6\text{V}, V_{SSH} = 1.2\text{V}, I_{SS} = 10\mu\text{A}$$

The time (T_{SS}) of duty change from 0% to 100% is 3.93s

$$C_{SS} = 1.0\text{nF} \gggg T_{SS} = 3.93\text{s}$$

$$C_{SS} = 2.2\text{nF} \gggg T_{SS} = 8.646\text{s}$$

:

:

$$C_{SS} = 5.0\text{nF} \gggg T_{SS} = 19.65\text{s}$$

Application Information

CT Capacitor

The capacitor that is connected from CT pin to GND determines the shutdown time and restart time.

$$\text{Locked Detection Time} = \frac{C_{CT} \times (V_{CTH} - 0.2V)}{I_{CT1}}$$

$$\text{Restart Time} = \frac{C_{CT} \times (V_{CTH} - V_{CTL})}{I_{CT1}}$$

$$\text{Shutdown Time} = \frac{C_{CT} \times (V_{CTH} - V_{CTL})}{I_{CT2}}$$

For example:

$$V_{CC} = 12V, C_{CT} = 1\mu F$$

$$V_{CTL} = 1V, V_{CTH} = 3V, I_{CT1} = 2\mu A, I_{CT2} = 0.2\mu A$$

$$\text{Locked Detection Time} = 1.4s$$

$$\text{Restart Time} = 1s$$

$$\text{Shutdown Time} = 10s$$

The value of C_{CT} must be considered with soft start up result.

RESET Capacitor

The capacitor that is connected from RESET pin to GND determines the Electric Motor braking time before the power on and restart of motor.

$$\text{Braking time} = \frac{C_{RESET} \times V_{RESET}}{I_{RESET}}$$

EX:

$$I_{RESET} = 1.2\mu A, V_{RESET} = 1.9V, C_{RESET} = 0.22\mu F$$

$$\text{Braking time} = 0.348s$$

Package Information

QFN4x4-24A

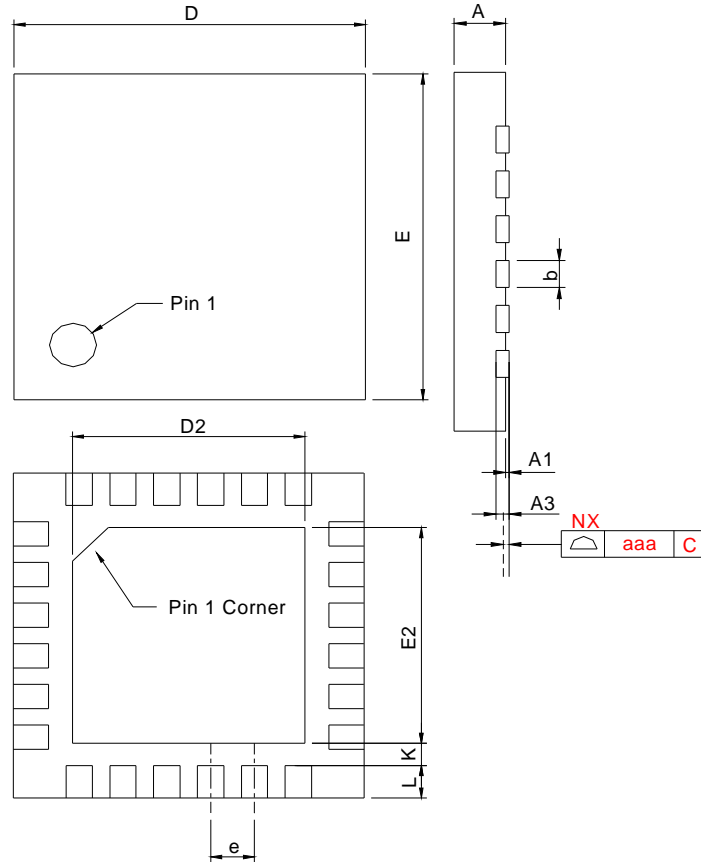

SYMBOL	QFN4*4-24A			
	MILLIMETERS		INCHES	
	MIN.	MAX.	MIN.	MAX.
A	0.80	1.00	0.032	0.039
A1	0.00	0.05	0.000	0.002
A3	0.20 REF		0.008 REF	
b	0.18	0.30	0.007	0.012
D	3.90	4.10	0.154	0.161
D2	2.00	2.50	0.079	0.098
E	3.90	4.10	0.154	0.161
E2	2.00	2.50	0.079	0.098
e	0.50 BSC		0.020 BSC	
L	0.35	0.45	0.014	0.018
K	0.20		0.008	
aaa	0.08		0.003	

Note : 1. Followed from JEDEC MO-220 WGGD-6.

Carrier Tape & Reel Dimensions

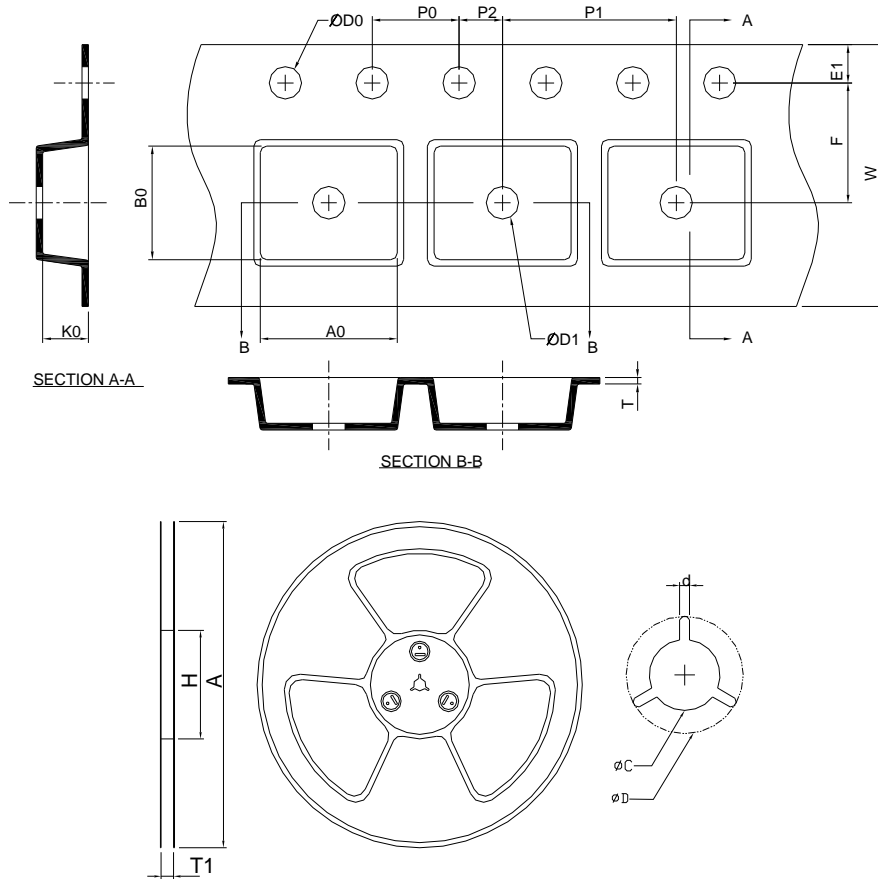

Application	A	H	T1	C	d	D	W	E1	F
QFN 4x4-24A	330.0±2.00	50 MIN.	12.4+2.00 -0.00	13.0+0.50 -0.20	1.5 MIN.	20.2 MIN.	12.0±0.30	1.75±0.10	5.5±0.05
	P0	P1	P2	D0	D1	T	A0	B0	K0
	4.0±0.10	8.0±0.10	2.0±0.05	1.5+0.10 -0.00	1.5 MIN.	0.6+0.00 -0.40	4.30±0.20	4.30±0.20	1.30±0.20

(mm)

Devices Per Unit

Package type	Packing	Quantity
QFN 4x4-24A	Tape & Reel	3000

Taping Direction Information

QFN4x4-24A

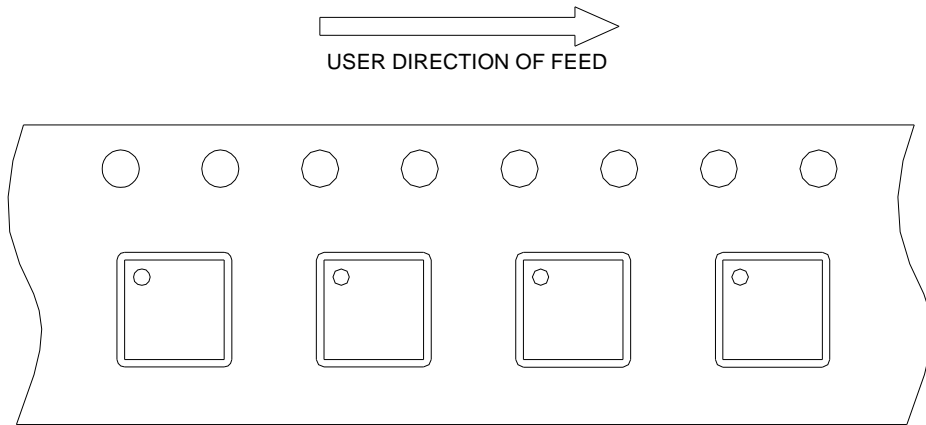

Classification Profile

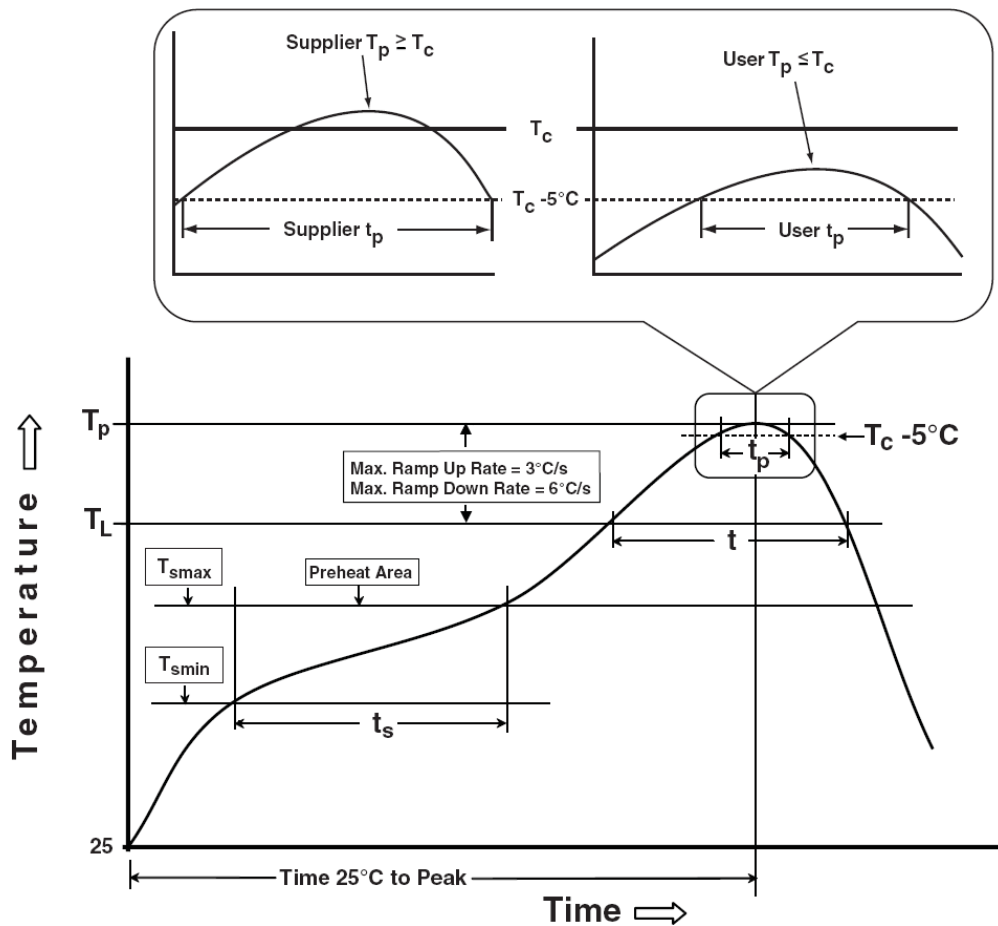

Classification Reflow Profiles

Profile Feature	Sn-Pb Eutectic Assembly	Pb-Free Assembly
Preheat & Soak Temperature min (T_{smin}) Temperature max (T_{smax}) Time (T_{smin} to T_{smax}) (t_s)	100 °C 150 °C 60-120 seconds	150 °C 200 °C 60-120 seconds
Average ramp-up rate (T_{smax} to T_p)	3 °C/second max.	3°C/second max.
Liquidous temperature (T_L) Time at liquidous (t_L)	183 °C 60-150 seconds	217 °C 60-150 seconds
Peak package body Temperature (T_p)*	See Classification Temp in table 1	See Classification Temp in table 2
Time (t_p)** within 5°C of the specified classification temperature (T_c)	20** seconds	30** seconds
Average ramp-down rate (T_p to T_{smax})	6 °C/second max.	6 °C/second max.
Time 25°C to peak temperature	6 minutes max.	8 minutes max.
* Tolerance for peak profile Temperature (T_p) is defined as a supplier minimum and a user maximum. ** Tolerance for time at peak profile temperature (t_p) is defined as a supplier minimum and a user maximum.		

Table 1. SnPb Eutectic Process – Classification Temperatures (T_c)

Package Thickness	Volume mm ³ <350	Volume mm ³ ≥350
<2.5 mm	235 °C	220 °C
≥2.5 mm	220 °C	220 °C

Table 2. Pb-free Process – Classification Temperatures (T_c)

Package Thickness	Volume mm ³ <350	Volume mm ³ 350-2000	Volume mm ³ >2000
<1.6 mm	260 °C	260 °C	260 °C
1.6 mm – 2.5 mm	260 °C	250 °C	245 °C
≥2.5 mm	250 °C	245 °C	245 °C

Reliability Test Program

Test item	Method	Description
SOLDERABILITY	JESD-22, B102	5 Sec, 245°C
HOLT	JESD-22, A108	1000 Hrs, Bias @ $T_j=125^\circ\text{C}$
PCT	JESD-22, A102	168 Hrs, 100%RH, 2atm, 121°C
TCT	JESD-22, A104	500 Cycles, -65°C~150°C
HBM	MIL-STD-883-3015.7	VHBM ≥ 2KV
MM	JESD-22, A115	VMM ≥ 200V
Latch-Up	JESD 78	10ms, $1_{tr} \geq 100\text{mA}$

Customer Service

Anpec Electronics Corp.

Head Office :

No.6, Dusing 1st Road, SBIP,
Hsin-Chu, Taiwan
Tel : 886-3-5642000
Fax : 886-3-5642050

Taipei Branch :

2F, No. 11, Lane 218, Sec 2 Jhongsing Rd.,
Sindian City, Taipei County 23146, Taiwan
Tel : 886-2-2910-3838
Fax : 886-2-2917-3838