

Three-Phase Sensor-Less Fan Motor Driver

Features

- **Three-Phase Full-Wave Sensor-Less Drive**
- **Adjustable Forced Commutation Frequency (for Start-up)**
- **Built-In External PWM or VSP Speed Control**
- **Built-In Quick Start Function**
- **FG, 1/2FG or RD Output**
- **Power Saving Function**
- **Built-In Lock Protection and Auto Restart Function**
- **Built-in Thermal Protection Circuit**
- **Lead Free and Green Device Available (RoHS Compliant)**

General Description

The APX9359A provides all the circuitry for sensor-less speed control of three-phase brushless DC motor. The controller functions include start-up circuit, back-EMF commutation control, Pulse Width Modulation (PWM) speed control, voltage speed control, lock protection, and thermal shutdown circuit. The APX9359A is suitable for both game machine and CPU cooler that need silent drivers. It is available in VTDFN2x2-10 package.

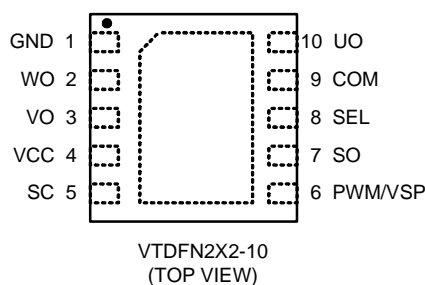

Pin Configuration



Applications

- **Motor Driver For Silent Fans**
- **Variable Speed Control Fans**

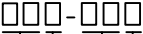
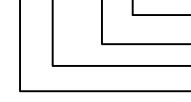
Ordering and Marking Information

<p>APX9359A </p> <p>  Assembly Material Handling Code Temperature Range Package Code </p>	<p>Package Code QF : VTDFN2X2-10 Operating Ambient Temperature Range I : -40 to 105 °C Handling Code TR : Tape & Reel Assembly Material G : Halogen and Lead Free Device</p>
<p>APX9359A QF : </p>	<p>X - Date Code</p>

Note: ANPEC lead-free products contain molding compounds/die attach materials and 100% matte tin plate termination finish; which are fully compliant with RoHS. ANPEC lead-free products meet or exceed the lead-free requirements of IPC/JEDEC J-STD-020C for MSL classification at lead-free peak reflow temperature. ANPEC defines "Green" to mean lead-free (RoHS compliant) and halogen free (Br or Cl does not exceed 900ppm by weight inhomogeneous material and total of Br and Cl does not exceed 1500ppm by weight).

ANPEC reserves the right to make changes to improve reliability or manufacturability without notice, and advise customers to obtain the latest version of relevant information to verify before placing orders.

Absolute Maximum Ratings (Note 1)

Symbol	Parameter	Rating	Unit
V _{CC}	VCC Pin Supply Voltage (VCC to GND)	-0.3 to 7	V
I _{OUT}	UO/O/WO Pin Output Current	1	A
V _{UO/V_{VO}/V_{WO}}	UO/O/WO Pin Output Voltage	-0.3 to 7	V
V _{PWM/VSP}	PWM/VSP Pin Maximum Input Voltage	-0.3 to 7	V
V _{SO}	SO Pin Output Voltage	-0.3 to 7	V
I _{SO}	SO Pin Maximum Output Sink Current	10	mA
T _J	Junction Temperature	-40 to 150	°C
T _{STG}	Storage Temperature	-65 to 150	°C
T _{SDR}	Maximum Lead Soldering Temperature (10 Seconds)	260	°C

Note 1: Stresses beyond those listed under "absolute maximum ratings" may cause permanent damage to the device. These are stress ratings only and functional operation of the device at these or any other conditions beyond those indicated under "recommended operating conditions" is not implied. Exposure to absolute maximum rating conditions for extended periods may affect device reliability.

Thermal Characteristics

Symbol	Parameter	Typical Value	Unit
θ_{JA}	Thermal Resistance-Junction to Ambient ^(Note 2) VTDFN2x2-10	104	°C/W
P _D	Power Dissipation, T _A =25 °C VTDFN2x2-10	1.2	W

Note 2: θ_{JA} is measured on a board (30x30x1.2mm, Glass epoxy). The Thermal Pad on the bottom of VTDFN2x2-10 package should be soldered directly to the PCB's Thermal Pad area that with several thermal vias connect to ground plane, and the PCB is a 2-layer, 10mm square with 2oz copper thickness.

Recommended Operating Conditions

Symbol	Parameter	Range	Unit
V _{CC}	VCC Pin Supply Voltage Range	2 to 6	V
V _{PWM/VSP}	PWM/VSP Pin Input Voltage Range	0 to V _{CC}	V
T _A	Ambient Temperature	-40 to 105	°C
I _{OUT}	UO/O/WO Pin Average Output Current	0 to 400	mA

Note 3: Refer to the typical application circuit.

Electrical Characteristics ($V_{CC}=5V$, $T_A=25^\circ C$, unless otherwise specified)

Symbol	Parameter	Test Conditions	APX9359A			Unit
			Min	Typ	Max	
SUPPLY CURRENT						
I_{CC1}	Operating Current	Rotation Mode	-	3	5	mA
I_{CC2}		Standby Mode (PWM=0)	-	100	150	μA
PWM CONTROL						
V_{PWMH}	PWM Input High Level Voltage		2.5	-	$V_{CC}+0.3$	V
V_{PWML}	PWM Input Low Level Voltage		-0.3	-	0.8	V
I_{PWMH}	PWM High Input Current	PWM=VCC	-	0	-	μA
I_{PWML}	PWM Low Input Current	PWM=GND	-	-10	-	μA
F_{PWM}	PWM Input Frequency		2	-	50	kHz
F_{OUT}	Output Switch Frequency		26	31	36	kHz
OUTPUT DRIVERS						
V_O	Output Driver Saturation Voltage	$I_{OUT} = 250mA$, Upper and Lower total	-	0.25	0.45	V
V_{SO}	SO Pin Low Voltage	$I_{SO} = 5mA$	-	0.1	0.3	V
I_{SO}	SO Pin Leakage Current	$V_{SO} = 5V$	-	<0.1	1	μA
LOCK PROTECTION						
T_{ON}	Lock Detection On Time		0.705	0.75	0.795	sec
T_{OFF}	Lock Detection Off Time		4.25	5	5.75	sec
Oscillator						
V_{SCH}	SC Pin High Level Voltage		1	1.2	1.4	V
V_{SCL}	SC Pin Low Level Voltage		0.5	0.6	0.7	V
I_{SC1}	SC Pin Charge Current	$V_{SC}=0V$	-	15	-	μA
I_{SC2}	SC Pin Discharge Current	$V_{SC}=1.2V$	-	15	-	μA
Quick Start						
T_{QS}	Quick Start Enable Time		-	10	-	ms
THERMAL SHUTDOWN						
OTS	Over Temperature Shutdown Threshold		-	165	-	$^\circ C$
	Over Temperature Shutdown Hysteresis		-	30	-	$^\circ C$

Pin Description

PIN		Function
NO.	NAME	
1	GND	Ground Pin.
2	WO	Driver Output Pin. Output signal for driving motor phase W.
3	VO	Driver Output Pin. Output signal for driving motor phase V.
4	VCC	Supply Voltage Input Pin.
5	SC	Start-up Commutation Time Setting. Connect a capacitor to GND to set start-up commutation time.
6	PWM/VSP	PWM or VSP Signal Input Pin. Input PWM or Voltage signal to control rotation speed.
7	SO	Rotation Speed Output or Rotation Detection Output. This is an open-drain output.
8	SEL	Mode Setting. Use a voltage divider from VCC to set SEL pin voltage for setting.
9	COM	Motor Neutral Point Input Pin.
10	UO	Driver Output Pin. Output signal for driving motor phase U.

Block Diagram

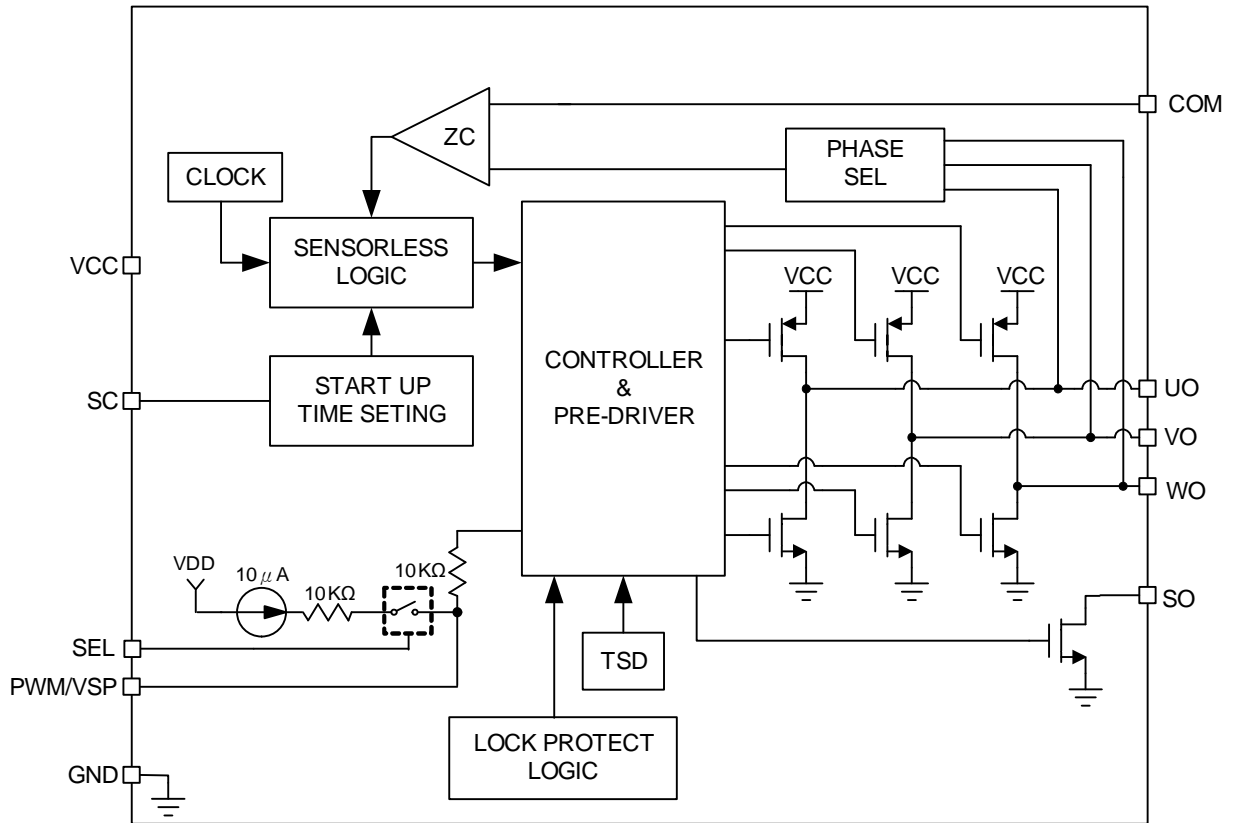

Typical Application Circuit

Circuit1: PWM Speed Control

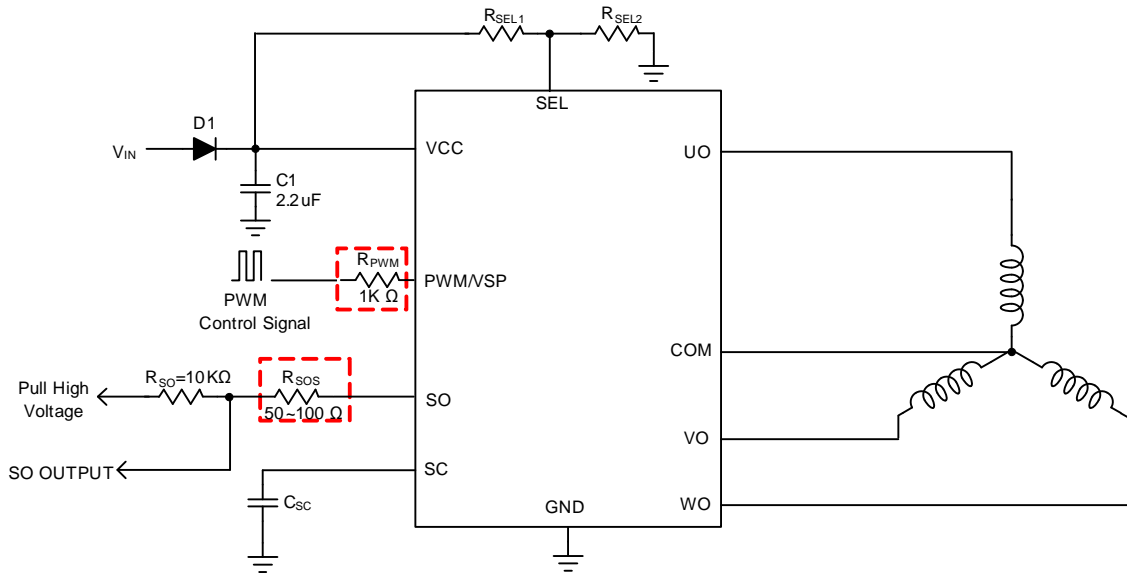

Note: 1. R_{PWM} and R_{SOS} are optional to protect internal circuit for abnormal voltage stress.

Circuit2: VSP Speed Control

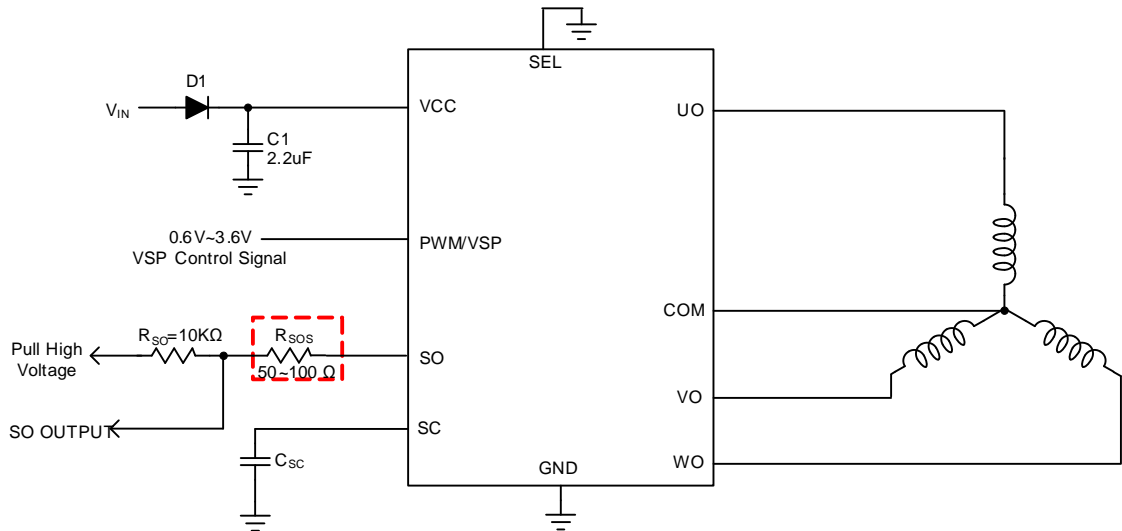

Note: 1. R_{SOS} is optional to protect internal circuit for abnormal voltage stress.
 2. VSP is prohibited floating.

Function Description

PWM Speed Control (fixed output frequency)

It is possible to change rotation speed of the motor by switching output transistor. The on-duty of switching depends on the signal from input of PWM terminal. The output PWM frequency is fixed to 31KHz typically.

VSP Speed Control

The APX9359A also support VSP input voltage speed control. When the SEL pin pulled down to GND, the VSP input pin to control the output duty directly.

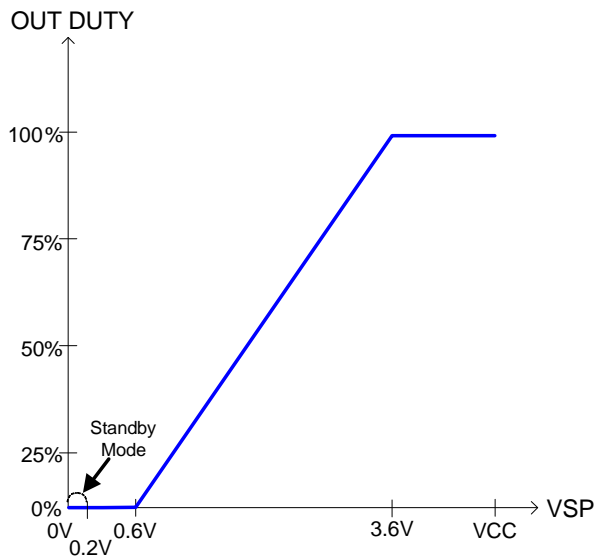

Figure 1: VSP Control

Quick Start and Standby Mode

This IC would enter standby mode when the PWM input keeps low level for more than 10ms (typ.). In standby mode, the supply current is around 100 μ A and the lock protection function doesn't work, therefore, starting fan is unobstructed when releasing standby mode.

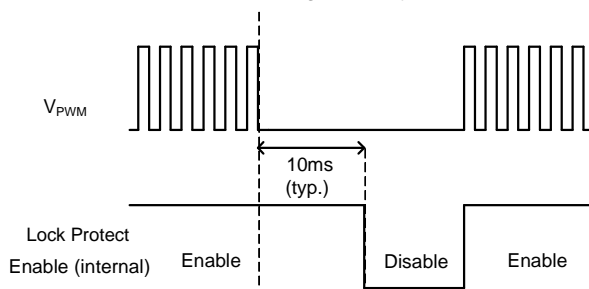

Figure 2. Quick Start Waveform

Function Description (Cont.)

SEL Control

The APX9359A support FG, 1/2FG or RD Output.

SEL Pin Input Voltage	R_{SEL1}/R_{SEL2}	SO Output	Speed Control
GND	Open/GND	FG	VSP
0.2(V) ~ 0.4*VCC(V)	30K Ω /10K Ω	RD	PWM
0.4*VCC(V) ~0.8*VCC(V)	10K Ω /15K Ω	1/2FG	PWM
VCC	VCC/ Open	FG	PWM

Table 1: SEL Pin Definition

SO Output

The SO pin is an open-drain output, connecting a pull up resistor to a high level voltage for the speed detection function. During the Lock Mode, the SO will always high (switch off). Open the terminal when not in use.

Lock Protection and Automatic Restart

The APX9359A provides the lock protection and automatic restart functions to prevent the coil burnout while the fan is locked. As the fan is locked, the IC will come into start-up operation for 0.75 second. Then, the IC will switch to lock protection mode to turn off output driver for 5 seconds. After lock protection mode, the IC switches to start-up operation again. If the locked condition still remains, the lock-and-restart process will be recurred until the locked condition is released.

Thermal Protection

The APX9359A has thermal protection. When internal junction temperature reaches 165°C, the output devices will be switched off. When the IC's junction temperature cools down 30°C, the thermal sensor will turn on the output devices again, resulting in a pulsed output during continuous thermal protection.

Application Information

Input Protection Diode & Capacitor

It is necessary to add a protection diode (D1) to prevent the damage from the power reverse connection. However, the protection diode will cause a voltage drop on the supply voltage. The current rating of the diode must be larger than the maximum output current. For the noise reduction purpose, a capacitor (C1) is connected between VCC and GND. (see Typical Application Circuit) It's suggested that C1 should be placed as close as possible in the VCC pin.

SC Capacitor

The capacitor connected between SC pin and GND can define the frequency of force commutation. The optimal design of the frequency could make sure the motor start-up in succeed. Its capacitance from 1nF to 10nF is recommended.

SO Resistor

The value of the SO resistor could be decided by the following equation:

$$R_{SO} = \frac{V_{CC} - V_{SO}}{I_{SO}}$$

For example:

$$V_{CC} = 5V, I_{SO} = 5mA, V_{SO} = 0.1V, R_{SO} = 0.98k\Omega$$

The value of resistor in the range of 1k Ω to 10k Ω is recommended.

Package Information

VTDFN2x2-10

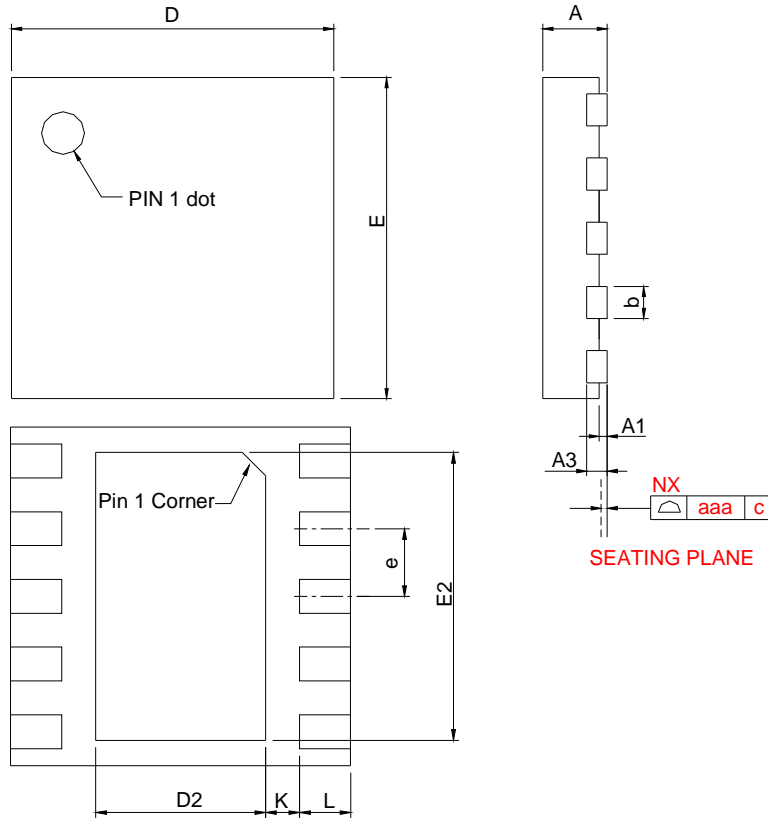

SYMBOL	VTDFN2*2-10			
	MILLIMETERS		INCHES	
	MIN.	MAX.	MIN.	MAX.
A	0.50	0.60	0.020	0.024
A1	0.00	0.05	0.000	0.002
A3	0.152 REF		0.006 REF	
b	0.15	0.25	0.006	0.010
D	1.90	2.10	0.075	0.083
D2	0.80	1.00	0.032	0.039
E	1.90	2.10	0.075	0.083
E2	1.40	1.60	0.055	0.063
e	0.40 BSC		0.016 BSC	
L	0.25	0.35	0.010	0.014
K	0.20		0.008	
aaa	0.08		0.003	

Carrier Tape & Reel Dimensions

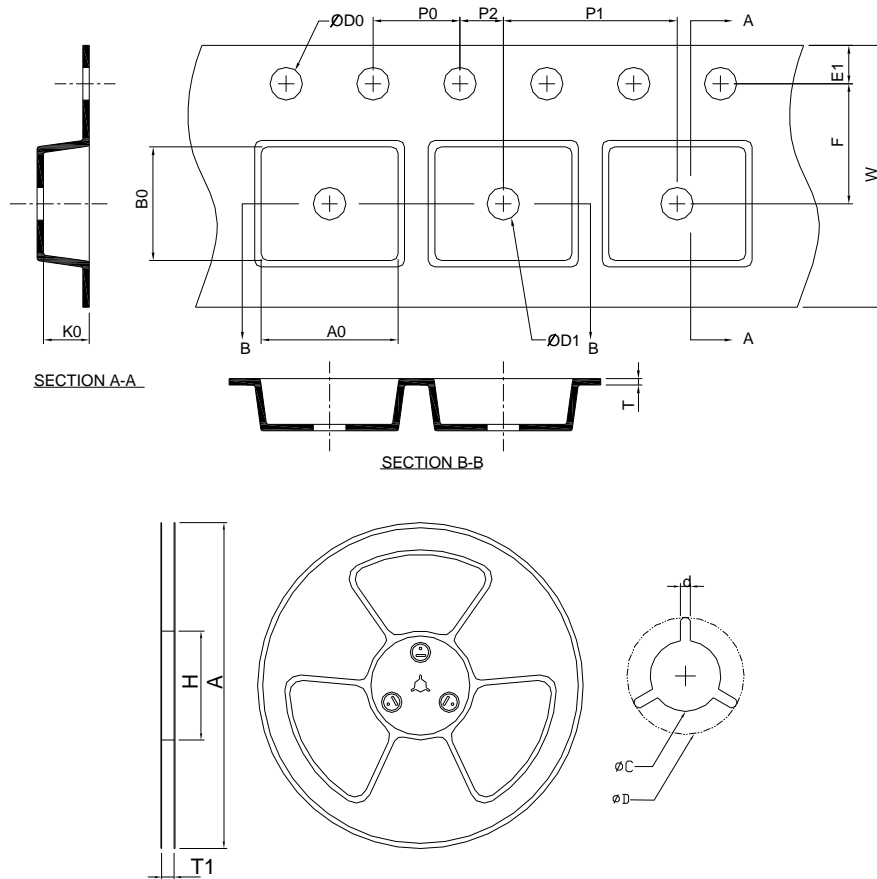

Application	A	H	T1	C	d	D	W	E1	F
VTDFN2x2-10	178.0±2.00	50 MIN.	8.4+2.00 -0.00	13.0+0.50 -0.20	1.5 MIN.	20.2 MIN.	8.0±0.20	1.75±0.10	3.5±0.05
	P0	P1	P2	D0	D1	T	A0	B0	K0
	4.0±0.10	4.0±0.10	2.0±0.05	1.5+0.10 -0.00	1.5 MIN.	0.6+0.00 -0.40	2.20±0.15	2.20±0.15	0.75±0.05

(mm)

Devices Per Unit

Package Type	Unit	Quantity
VTDFN2x2-10	Tape & Reel	3000

Taping Direction Information

VTDFN2x2-10

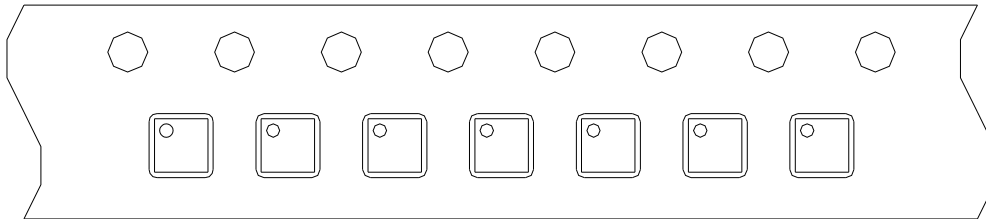
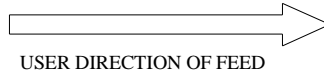

Classification Profile

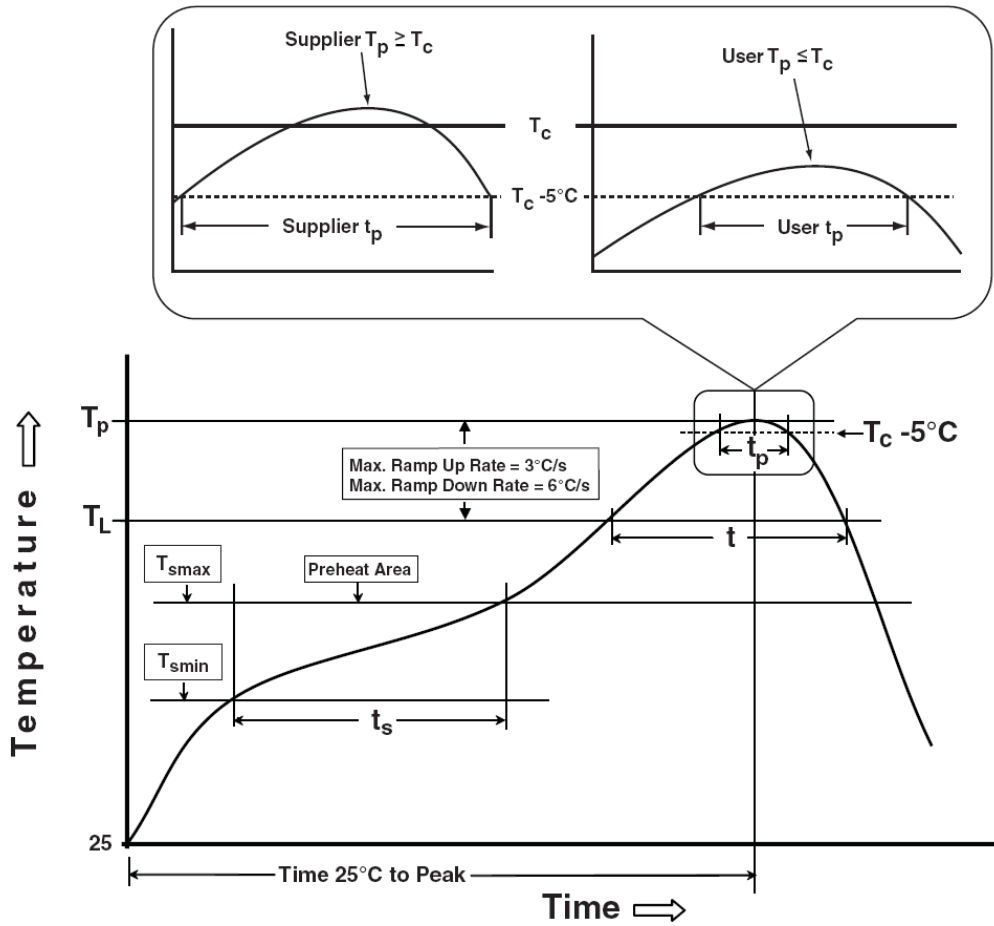

Classification Reflow Profiles

Profile Feature	Sn-Pb Eutectic Assembly	Pb-Free Assembly
Preheat & Soak Temperature min (T_{smin}) Temperature max (T_{smax}) Time (T_{smin} to T_{smax}) (t_s)	100 °C 150 °C 60-120 seconds	150 °C 200 °C 60-120 seconds
Average ramp-up rate (T_{smax} to T_p)	3 °C/second max.	3°C/second max.
Liquidous temperature (T_L) Time at liquidous (t_L)	183 °C 60-150 seconds	217 °C 60-150 seconds
Peak package body Temperature (T_p)*	See Classification Temp in table 1	See Classification Temp in table 2
Time (t_p)** within 5°C of the specified classification temperature (T_c)	20** seconds	30** seconds
Average ramp-down rate (T_p to T_{smax})	6 °C/second max.	6 °C/second max.
Time 25°C to peak temperature	6 minutes max.	8 minutes max.
* Tolerance for peak profile Temperature (T_p) is defined as a supplier minimum and a user maximum. ** Tolerance for time at peak profile temperature (t_p) is defined as a supplier minimum and a user maximum.		

Table 1. SnPb Eutectic Process – Classification Temperatures (T_c)

Package Thickness	Volume mm ³ <350	Volume mm ³ ≥350
<2.5 mm	235 °C	220 °C
≥2.5 mm	220 °C	220 °C

Table 2. Pb-free Process – Classification Temperatures (T_c)

Package Thickness	Volume mm ³ <350	Volume mm ³ 350-2000	Volume mm ³ >2000
<1.6 mm	260 °C	260 °C	260 °C
1.6 mm – 2.5 mm	260 °C	250 °C	245 °C
≥2.5 mm	250 °C	245 °C	245 °C

Reliability Test Program

Test item	Method	Description
SOLDERABILITY	JESD-22, B102	5 Sec, 245°C
HOLT	JESD-22, A108	1000 Hrs, Bias @ $T_j=125^{\circ}C$
PCT	JESD-22, A102	168 Hrs, 100%RH, 2atm, 121°C
TCT	JESD-22, A104	500 Cycles, -65°C~150°C
HBM	MIL-STD-883-3015.7	VHBM ≥ 2KV
MM	JESD-22, A115	VMM ≥ 200V
Latch-Up	JESD 78	10ms, $1_{tr} \geq 100mA$

Customer Service

Anpec Electronics Corp.

Head Office :

No.6, Dusing 1st Road, SBIP,
Hsin-Chu, Taiwan
Tel : 886-3-5642000
Fax : 886-3-5642050

Taipei Branch :

2F, No. 11, Lane 218, Sec 2 Jhongsing Rd.,
Sindian City, Taipei County 23146, Taiwan
Tel : 886-2-2910-3838
Fax : 886-2-2917-3838