

# 1/2.6-inch 2.3 Mp CMOS Digital Image Sensor with Global Shutter



**ON Semiconductor®**

[www.onsemi.com](http://www.onsemi.com)

## AR0234CS

### Description

The AR0234CS is a 1/2.6-inch 2Mp CMOS digital image sensor with an active-pixel array of 1920 (H) x 1200 (V). It incorporates a new innovative global shutter pixel design optimized for accurate and fast capture of moving scenes at full resolution 120 frame per second. The sensor produces clear, low noise images in both low-light and bright scenes. It includes sophisticated camera functions such as auto exposure control, windowing, row skip mode, column-skip mode, pixel-binning and both video and single frame modes. It is programmable through a simple two-wire serial interface. The AR0234CS produces extraordinarily clear, sharp digital pictures with an industry leading Global Shutter Efficiency, and its ability to capture both continuous video and single frames makes it the perfect choice for a wide range of applications, including scanning and industrial inspection.

**Table 1. KEY PERFORMANCE PARAMETERS**

Parameter	Typical Value
Optical Format	1/2.6-inch (6.8 mm)
Active Pixels	1920 (H) x 1200 (V) = 2.3 Mp
Pixel Size	3.0 μm
Color Filter Array	RGB or Monochrome
Chief Ray Angle	0° or 28°
Shutter Type	Global Shutter
Input Clock Range	6–54 MHz
Output Pixel Clock (Maximum)	90 MHz
Output	
Serial	8-bit/10-bit MIPI, 1, 2, or 4-lane D-PHY 1.2, CSI-2 1.2
Parallel	8-bit/10-Bit
Frame Rate	
Full resolution	120fps (4-lane MIPI), Default Max data rate 900 Mbps/lane 30 fps (Parallel)
720p	120 fps (MIPI) 50 fps (Parallel)
Responsivity	
Monochrome	56 Ke/lux*s
Color	22.3 Ke/lux*s
SNRMAX	38 dB
Dynamic Range	71.4 dB
Supply Voltage	
I/O	1.8 or 2.8 V
Digital	1.2 V
Analog	2.8 V
Operational Power Consumption	<395 mW at 120 FPS, Full Resolution
Operating Temperature	–40°C to + 85°C (Ambient) –40°C to +105°C (Junction)
Package Options	9.995 x 5.595 CSP Bare Die

### ORDERING INFORMATION

See detailed ordering and shipping information on page 2 of this data sheet.

### Features

- Superior Low-light and IR Performance
- HD Video (1080p120)
- 8-bit/10-bit MIPI, 1/2/4-lane MIPI or 8-bit/10-bit Parallel Data Interface
- Automatic Black Level Calibration (ABLC)
- On-chip Auto Exposure Control with Statistics Engine for Any 5x5 Programmable Region of Interest (ROI).
- Horizontal and Vertical Mirroring, Windowing and Pixel Binning
- Flexible Control for Row and Column Skip Mode
- Different On-Chip Trigger Modes for Synchronization
- Built in Strobe Illumination Control
- On-Chip Phase Lock Loop (PLL)
- On-Chip Lens Shading Correction

This document, and the information contained herein, is CONFIDENTIAL AND PROPRIETARY and the property of Semiconductor Components Industries, LLC., dba ON Semiconductor. It shall not be used, published, disclosed or disseminated outside of the Company, in whole or in part, without the written permission of ON Semiconductor. Reverse engineering of any or all of the information contained herein is strictly prohibited.

© 2017, SCILLC. All Rights Reserved.

**Applications**

- Bar Code Scanner
- Gesture Recognition
- 3D Scanning
- Positional Tracking
- Iris Scanning
- Augmented Reality
- Virtual Reality
- Biometrics
- Machine Vision

**ORDERING INFORMATION**

**Table 2. AVAILABLE PART NUMBERS**

Part Number	Product Description	Orderable Product Attribute Description
AR0234CSSM28SUKA0-CP	2.3MP 1/2.6", Mono, 28° CRA	CSP Chip Tray with Protective Film
AR0234CSSM28SUKA0-CR	2.3MP 1/2.6", Mono, 28° CRA	CSP Chip Tray without Protective Film
AR0234CSSM28SUKA0-CP1	2.3MP 1/2.6", Mono, 28° CRA	CSP Chip Tray with Protective Film Low MOQ
AR0234CSSM28SUD20	2.3MP 1/2.6", Mono, 28° CRA	Bare Die
AR0234CSSM28SUKAH3-GEVB	2.3MP 1/2.6", Mono, 28° CRA	Demo Headboard

AR0234CSSM00SUKA0-CP	2.3MP 1/2.6", Mono, 0° CRA	CSP Chip Tray with Protective Film
AR0234CSSM00SUKA0-CR	2.3MP 1/2.6", Mono, 0° CRA	CSP Chip Tray without Protective Film
AR0234CSSM00SUKA0-CP1	2.3MP 1/2.6", Mono, 0° CRA	CSP Chip Tray with Protective Film Low MOQ
AR0234CSSM00SUD20	2.3MP 1/2.6", Mono, 0° CRA	Bare Die
AR0234CSSM00SUKAH3-GEVB	2.3MP 1/2.6", Mono, 0° CRA	Demo Headboard

AR0234CSSC28SUKA0-CP	2.3MP 1/2.6", RGB, 28° CRA	CSP Chip Tray with Protective Film
AR0234CSSC28SUKA0-CR	2.3MP 1/2.6", RGB, 28° CRA	CSP Chip Tray without Protective Film
AR0234CSSC28SUKA0-CP1	2.3MP 1/2.6", RGB, 28° CRA	CSP Chip Tray with Protective Film Low MOQ
AR0234CSSC28SUD20	2.3MP 1/2.6", RGB, 28° CRA	Bare Die
AR0234CSSC28SUKAH3-GEVB	2.3MP 1/2.6", RGB, 28° CRA	Demo Headboard

AR0234CSSC00SUKA0-CP	2.3MP 1/2.6", RGB, 0° CRA	CSP Chip Tray with Protective Film
AR0234CSSC00SUKA0-CR	2.3MP 1/2.6", RGB, 0° CRA	CSP Chip Tray without Protective Film
AR0234CSSC00SUKA0-CP1	2.3MP 1/2.6", RGB, 0° CRA	CSP Chip Tray with Protective Film Low MOQ
AR0234CSSC00SUD20	2.3MP 1/2.6", RGB, 0° CRA	Bare Die
AR0234CSSC00SUKAH3-GEVB	2.3MP 1/2.6", RGB, 0° CRA	Demo Headboard

NOTE: Please check with an ON Semiconductor sales representative for availability of these parts.

**Table 3. FRAME RATES FOR MASTER, AUTOMATIC TRIGGER AND MULTI-SENSOR SYNC MODE**

Resolution	Interface	Frame Rate (frames per sec)
Full Resolution 1920x1200	MIPI	120
		60
		30
	Parallel	30
2x2_Binning 960x600	MIPI	237
		120

**Table 4. FRAME RATES FOR PULSE TRIGGER MODE**

Resolution	Interface	Frame Rate (frames per sec)
Full Resolution 1920x1200	MIPI	60
		30
	Parallel	30
2x2_Binning 960x600	MIPI	120
		60

## GENERAL DESCRIPTION

The ON Semiconductor AR0234CS can be operated in its default mode or programmed for frame size, exposure, gain, and other parameters. The default mode output is a full-resolution image at 120 frames per second (fps). It outputs 8-bit or 10-bit raw data using parallel output ports or 10-bit or 8-bit using serial (MIPI) output ports. The device may be operated in video (master) mode or in frame trigger mode.

FRAME\_VALID and LINE\_VALID signals are output on dedicated pins, along with a synchronized pixel clock. A dedicated FLASH pin can be programmed to control external LED or flash exposure illumination.

The AR0234CS includes additional features to allow application-specific tuning: windowing, adjustable auto-exposure control, auto black level correction,

on-board temperature sensor, row-skip and column-skip modes and binning modes.

The sensor is designed to operate in a wide ambient temperature range ( $-40^{\circ}\text{C}$  to  $+85^{\circ}\text{C}$  ambient).

## FUNCTIONAL OVERVIEW

The AR0234CS is a global shutter sensor that generates a stream of pixel data at a constant frame rate. It uses an on-chip, phase-locked loop (PLL) that can be optionally enabled to generate all internal clocks from a single master input clock running between 6 and 54 MHz. The maximum output pixel rate is 90 Mp/s for parallel interface and 90 Mp/s per lane for MIPI interface, corresponding to a clock rate of 90 MHz. Figure 1 shows a block diagram of the sensor.

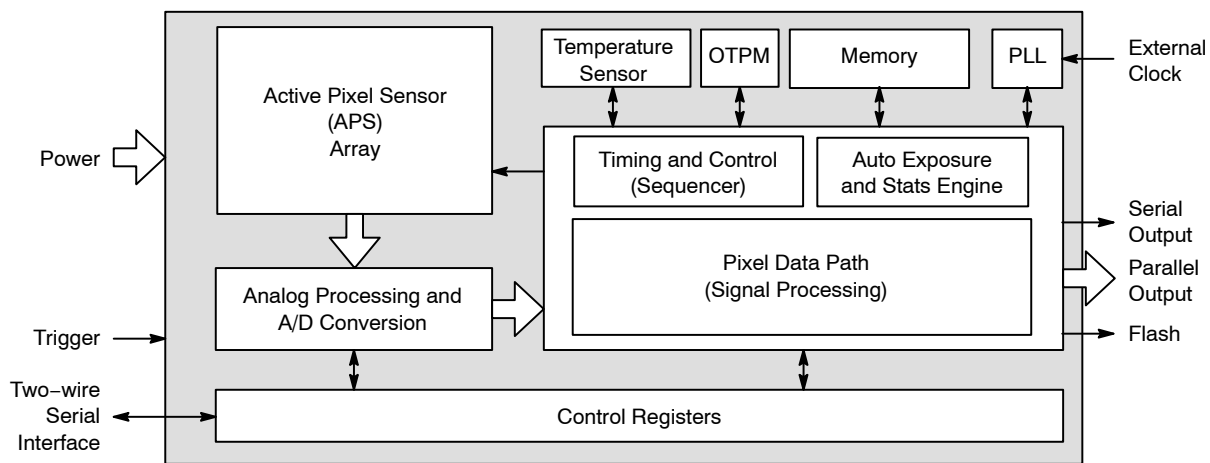

Figure 1. Block Diagram

User interaction with the sensor is through the two-wire serial bus, which communicates with the array control, analog signal chain, and digital signal chain. The core of the sensor is a 2.3 Mp Active-Pixel Sensor array. The AR0234CS features global shutter technology for accurate capture of moving images. The exposure of the entire array is controlled by programming the integration time by register setting. All pixels simultaneously integrate light and store signal at the pixel. Once a row readout sequence has been initiated, each pixel's stored signal is then transferred through the analog signal chain (providing offset and gain) and then through each column analog-to-digital converter (ADC). The output from the ADC is a 10-bit value for each pixel in the array. The ADC output passes through a digital processing signal chain (which provides further data path corrections and applies digital gain). The pixel data are output at a rate of up to 90 Mp/s, for parallel interface and 90 Mp/s per lane for MIPI interface to frame and line synchronization signals.

## FEATURES OVERVIEW

The AR0234CS Global Shutter sensor has a wide array of features to enhance functionality and to increase versatility. A summary of features follows.

- **3.0  $\mu\text{m}$  Global Shutter Pixel**  
To improve the low light performance and to capture the moving images accurately a large (3.0  $\mu\text{m}$ ) global shutter pixel is implemented for better image optimization.
- **Operating Modes**  
The AR0234CS works in master (video), Slave/ Trigger (single frame), or Auto Trigger modes. In master mode, the sensor generates the integration and readout timing. In Slave/trigger mode, it accepts a trigger from external host to start exposure, then generates the exposure and readout timing. The external trigger signal allows for precise control of frame rate and register change

- updates. The exposure time is programmed through the two-wire serial interface for both modes.
- Window Control  
Configurable window size and blanking times allow a wide range of resolutions and frame rates. Digital binning and skipping modes are supported, as are vertical and horizontal mirror operations.
  - Frame Rate  
AR0234CS is capable of running up to 120 fps at full (1920 x 1200) resolution for MIPI interface and 30 fps at full resolution for parallel interface.
  - Embedded Data and Statistics  
The AR0234CS has the capability to output image data and statistics embedded within the frame timing.
  - Multi-Camera Synchronization  
The AR0234CS supports advanced line synchronization controls for multi-camera (stereo) support.
  - Context Switching and Register Updates  
Context switching may be used to rapidly switch between two sets of register values.
  - Gain  
A programmable analog gain of 1.68x to 16x applied globally to all color channels is available, along with a digital gain of 1x to 16x that may be configured on a per color channel basis. Programmable analog gain for Parallel interface is limited to 8x.
  - Automatic Exposure Control  
The integrated automatic exposure control may be used to ensure optimal settings of exposure and gain are computed and updated every other frame. Image can be partitioned into 5 x 5 programmable ROI. Each of these 25 ROI can be selected or deselected for AEC calculation.
  - MIPI  
The AR0234CS Global Shutter image sensor supports one, two and four lanes of MIPI data. Compliant to MIPI standards:
    - ◆ MIPI Alliance Standard for CSI-2 version 1.2
    - ◆ MIPI Alliance Standard for D-PHY version 1.2
  - PLL  
An on chip PLL provides reference clock flexibility and supports spread spectrum sources for improved EMI performance.
  - Reset  
The AR0234CS may be reset by a register write, or by a dedicated input pin.
  - Output Enable  
The AR0234CS output pins may be tri-stated using a dedicated output enable pin.
  - Temperature Sensor
  - Black Level Correction  
The AR0234 sensor has built in controls for black level (delta dark) correction and calibration. The magnitude of dark current can be measured by utilizing optically dark rows and used to compensate black level in the visible array.
  - Row Noise Correction  
Row Noise Correction feature cancels the row to row variation in the image caused by variation in the signal chain in every row readout
  - Test Patterns  
Several test patterns may be enabled for debug purposes. These include a solid color, color bar, fade to gray, and a walking 1s test pattern.
  - Silicon/OTPM Revision Information  
A revision register is provided to read out (via I<sup>2</sup>C) silicon and OTPM revision information. This will be helpful to distinguish material if there are future OTPM or silicon revisions.
  - Lens Shading Correction  
An on-chip lens shading correction algorithm is included which can be used to correct lens shading and eliminate fixed pattern noise (FPN).
  - Compression  
AR0234CS can optionally compress 10-bit data to 8-bit using DPCM compression.

**ACTIVE ARRAY**

The AR0234CS active pixel array is configured as 1920 columns by 1200 rows. The first active pixel is top right corner of the active pixel array (see Figures 2 and 3 below).

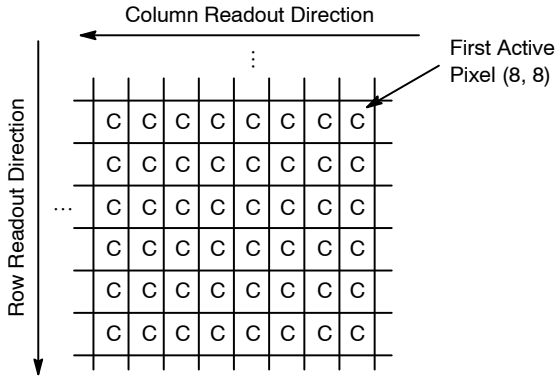

**Figure 2. Pixel Mono Pattern Detail (Top Right Corner)**

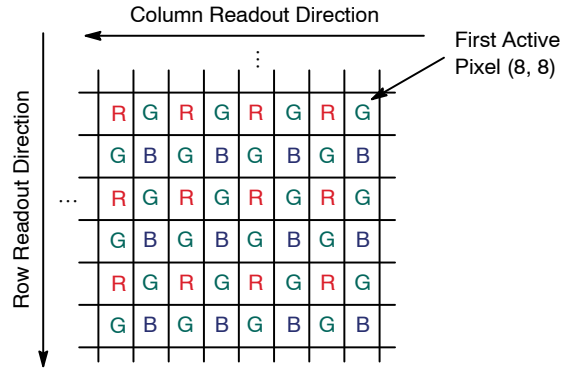

**Figure 3. Pixel Color Pattern Detail (Top Right Corner)**

**CONFIGURATION AND PINOUT**

The figures and tables below show a typical configuration for the AR0234CS image sensor and show the package pinouts.

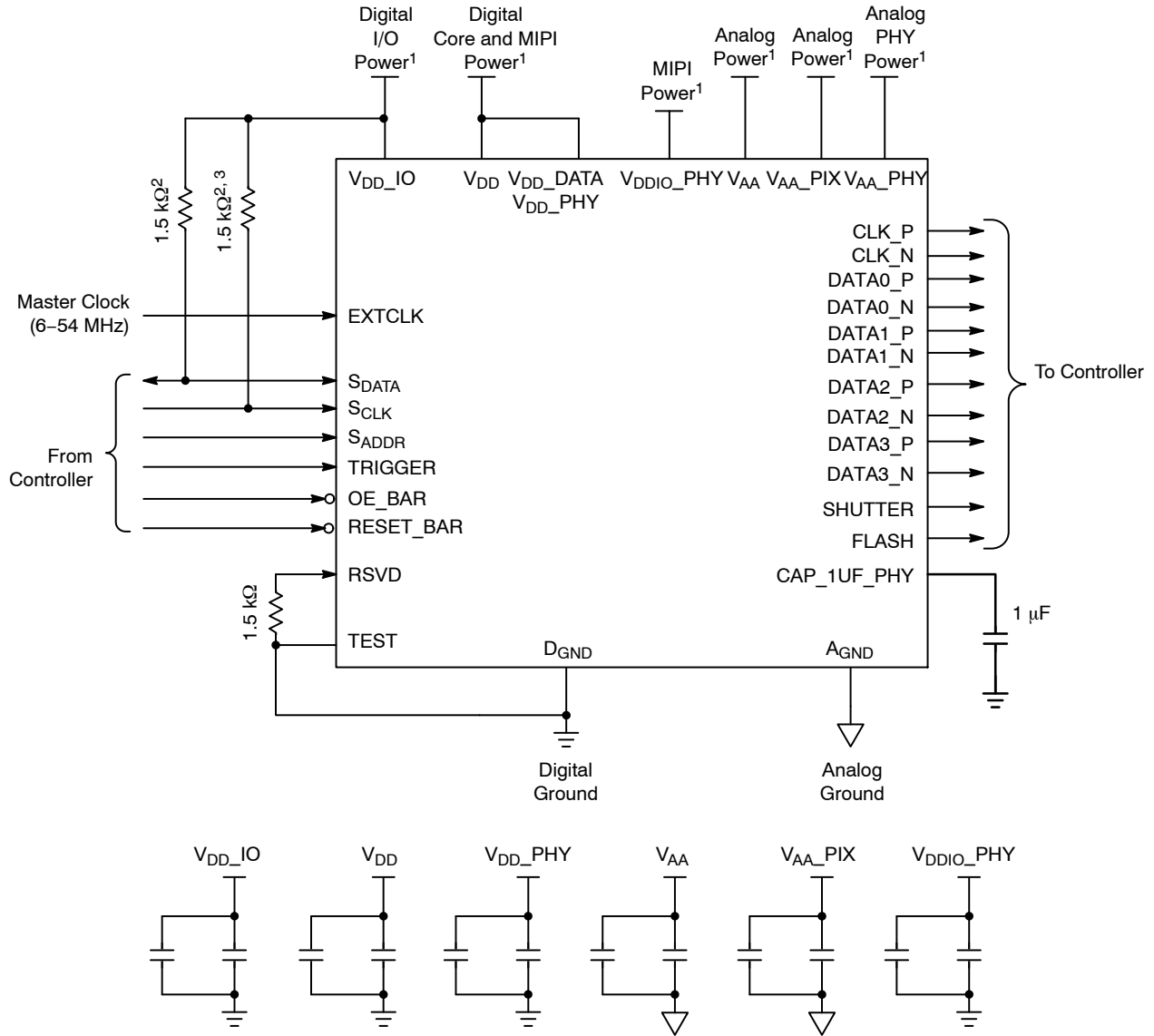

**Notes:**

1. All power supplies must be adequately decoupled.
2. ON Semiconductor recommends a resistor value of 1.5 k $\Omega$ , but a greater value may be used for slower two-wire speed.
3. This pull-up resistor is not required if the controller drives a valid logic level on S<sub>CLK</sub> at all times.
4. The parallel interface output pads can be left unconnected if the serial output interface is used.
5. Analog and digital grounds need to be connected at a single point.
6. ON Semiconductor recommends that 0.1  $\mu$ F and 10  $\mu$ F decoupling capacitors for each power supply are mounted as close as possible to the pad. Actual values and results may vary depending on the layout and design considerations. Refer to the AR0234CS demo headboard schematics for circuit recommendations.
7. ON Semiconductor recommends that analog power planes be placed in a manner such that coupling with the digital power planes is minimized.
8. It is recommended that V<sub>DD\\_PHY</sub> and V<sub>DD\\_DATA</sub> are tied to V<sub>DD</sub> (1.2 V).
9. It is recommended that V<sub>AA\\_PHY</sub> is connected to 2.8 V.
10. V<sub>DDIO\\_PHY</sub> should be connected to 1.8 V only.

**Figure 4. Serial 4-lane MIPI Interface**

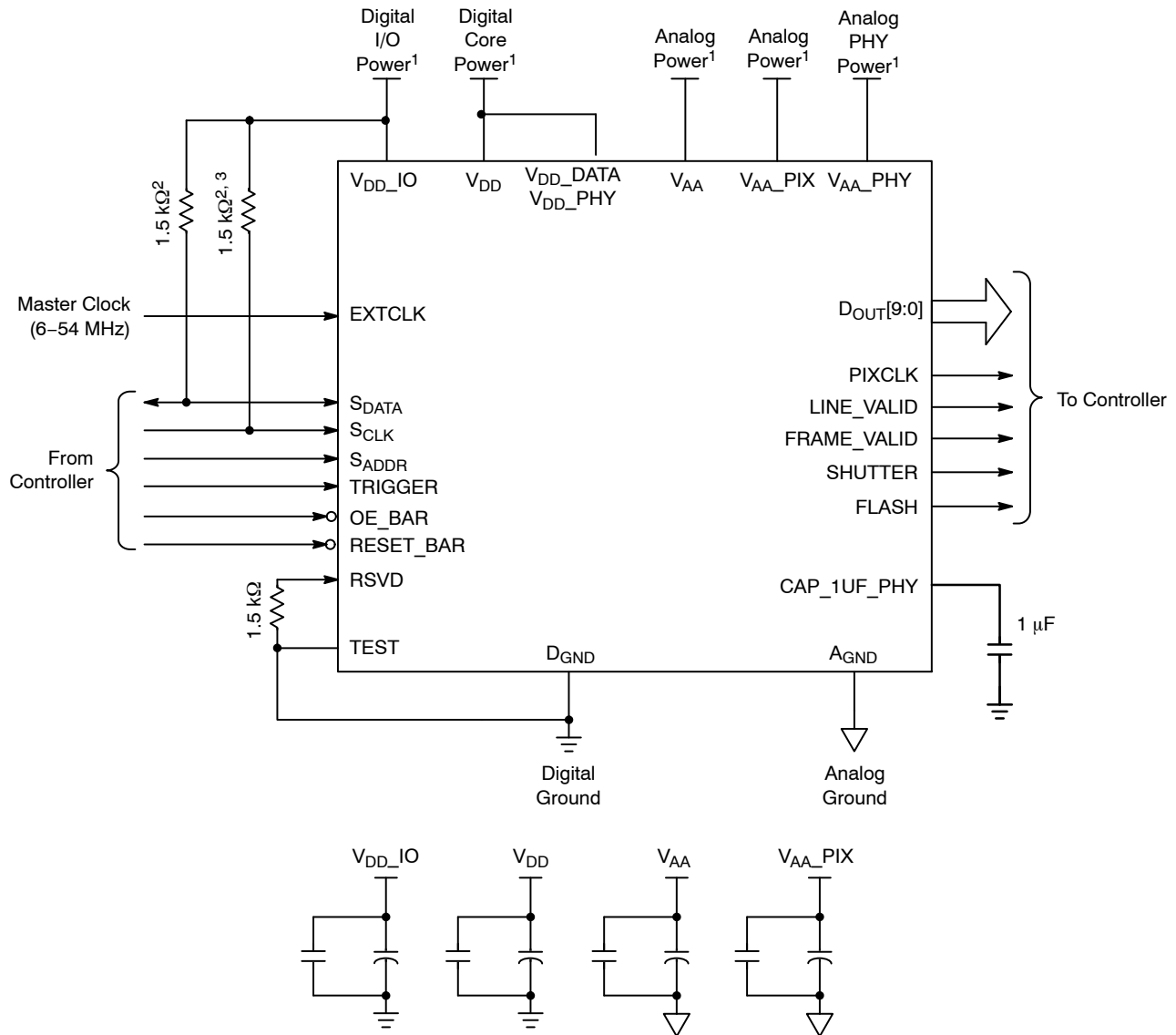

## Notes:

1. All power supplies must be adequately decoupled.
2. ON Semiconductor recommends a resistor value of 1.5 kΩ, but a greater value may be used for slower two-wire speed.
3. This pull-up resistor is not required if the controller drives a valid logic level on S<sub>CLK</sub> at all times.
4. The serial interface output pads can be left unconnected if the parallel output interface is used.
5. Analog and digital grounds need to be connected at a single point.
6. ON Semiconductor recommends that 0.1 μF and 10 μF decoupling capacitors for each power supply are mounted as close as possible to the pad. Actual values and results may vary depending on the layout and design considerations. Refer to the AR0234CS demo headboard schematics for circuit recommendations.
7. ON Semiconductor recommends that analog power planes be placed in a manner such that coupling with the digital power planes is minimized.
8. It is recommended that V<sub>DD\_PHY</sub> and V<sub>DD\_DATA</sub> are tied to V<sub>DD</sub> (1.2 V).
9. It is recommended that V<sub>AA\_PHY</sub> is connected to 2.8 V.

Figure 5. Parallel Interface

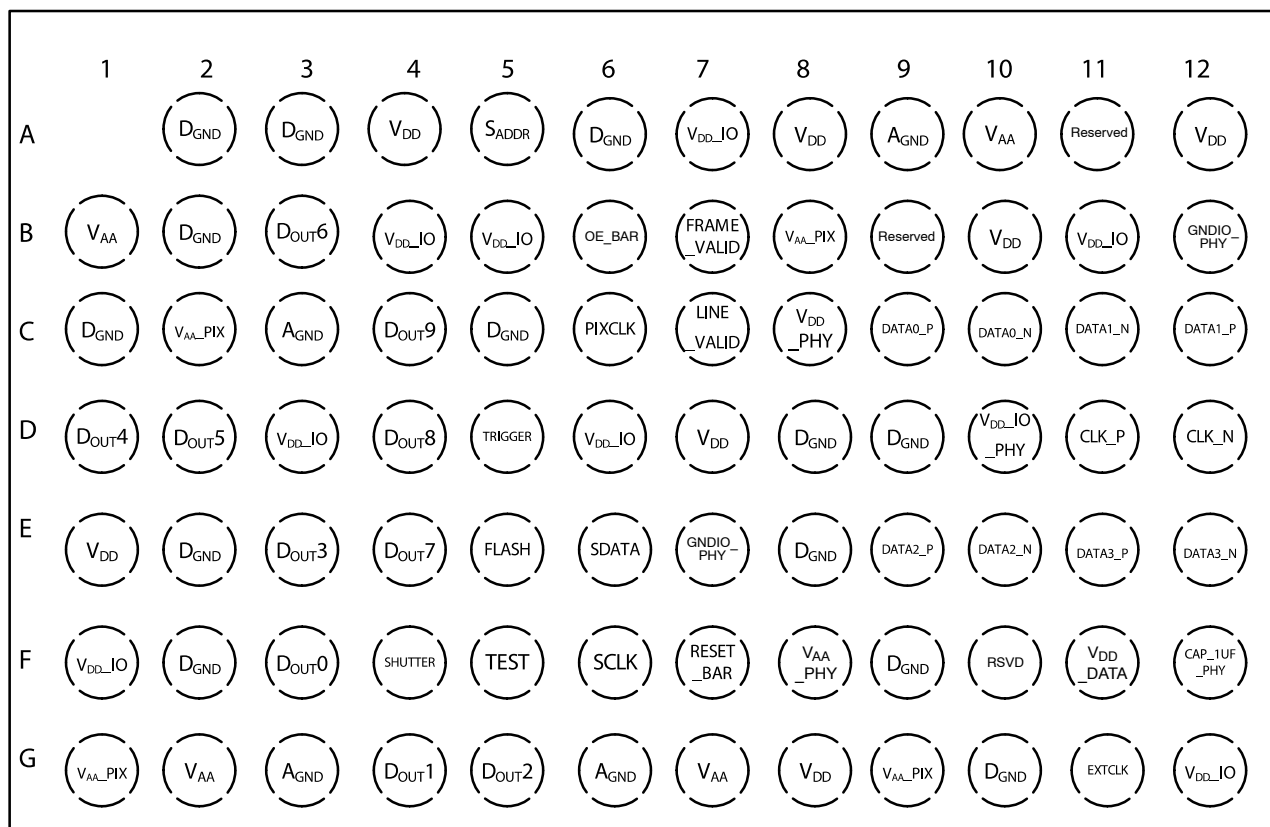

Figure 6. 9.995 x 5.595 mm 83-ball CSP Package (Top View)

Table 5. PIN DESCRIPTIONS – 83-BALL CSP PACKAGE

Name	CSP Ball	Type	Description
DATA0_N	C10	Output	MIPI serial data, lane 0, differential N
DATA0_P	C9	Output	MIPI serial data, lane 0, differential P
DATA1_N	C11	Output	MIPI serial data, lane 1, differential N
DATA1_P	C12	Output	MIPI serial data, lane 1, differential P
DATA2_N	E10	Output	MIPI serial data, lane 2, differential N
DATA2_P	E9	Output	MIPI serial data, lane 2, differential P
DATA3_N	E12	Output	MIPI serial data, lane 3, differential N
DATA3_P	E11	Output	MIPI serial data, lane 3, differential P
CLK_N	D12	Output	MIPI serial clock differential N
CLK_P	D11	Output	MIPI serial clock differential P
VAA	A10, B1, G2, G7	Power	Analog Power (2.8 V)
VAA_PHY	F8	Power	Analog PHY power supply. Analog power supply for the serial interface (2.8 V).
EXTCLK	G11	Input	External input clock
VDD_PHY	C8	Power	MIPI Power Supply (1.2 V)
VDDIO_PHY	D10	Power	I/O Power Supply (1.8 V)
DGND	A2 A3, A6, B2, C1, C5, D8, D9, E2, E8, F2, F9, G10	Power	Digital GND
GNDIO_PHY	B12, E7	Power	Connect to DGND.
VDD	A4, A8, A12, B10, D7, E1, G8	Power	Digital Power (1.2 V)



**Table 5. PIN DESCRIPTIONS – 83-BALL CSP PACKAGE** (continued)

Name	CSP Ball	Type	Description
V <sub>DD</sub> _DATA	F11	Power	MIPI PHY Power (1.2 V)
AGND	A9, C3, G3, G6	Power	Analog GND
SADDR	A5	Input	Two-Wire Serial address select
SCLK	F6	Input	Two-Wire Serial clock input
SDATA	E6	I/O	Two-Wire Serial data I/O
V <sub>AA</sub> _PIX	B8, C2, G1, G9	Power	Pixel Power (2.8 V)
LINE_VALID	C7	Output	Asserted when DOUT line data is valid
FRAME_VALID	B7	Output	Asserted when DOUT frame data is valid
PIXCLK	C6	Output	Pixel clock out. DOUT is valid on rising edge of this clock
SHUTTER	F4	Output	Control of external mechanical shutter
FLASH	E5	Output	Control signal to drive external light sources
V <sub>DD</sub> _IO	A7, B4, B5, B11, D3, D6, F1, G12	Power	I/O supply power (1.8 V or 2.8 V)
DOUT7	E4	Output	Parallel pixel data output
DOUT8	D4	Output	Parallel pixel data output
DOUT9	C4	Output	Parallel pixel data output (MSB)
TEST	F5	Input	Manufacturing test enable pin (connect to DGND)
DOUT4	D1	Output	Parallel pixel data output
DOUT5	D2	Output	Parallel pixel data output
DOUT6	B3	Output	Parallel pixel data output
TRIGGER	D5	Input	Exposure synchronization input
OE_BAR	B6	Input	Output enable (active LOW). This pin is used for Parallel interface only.
DOUT0	F3	Output	Parallel pixel data output (LSB)
DOUT1	G4	Output	Parallel pixel data output
DOUT2	G5	Output	Parallel pixel data output
DOUT3	E3	Output	Parallel pixel data output
RSVD	F10	Input	Must be connected with 1.5 k $\Omega$ resistor between this pin and DGND.
RESET_BAR	F7	Input	Asynchronous reset (active LOW). All settings are restored to factory default
CAP_1UF_PHY	F12	Power	External bypass capacitor for MIPI Regulator
Reserved	A11, B9	N/A	Reserved (do not connect)

## TWO-WIRE SERIAL REGISTER INTERFACE

The two-wire serial interface bus enables read/write access to control and status registers within the AR0234CS.

The interface protocol uses a master/slave model in which a master controls one or more slave devices. The sensor acts as a slave device. The master generates a clock ( $S_{CLK}$ ) that is an input to the sensor and is used to synchronize transfers. Data is transferred between the master and the slave on a bidirectional signal ( $S_{DATA}$ ).  $S_{DATA}$  is pulled up to  $V_{DD\_IO}$  off-chip by a 1.5 k $\Omega$  resistor. Either the slave or master device can drive  $S_{DATA}$  LOW – the interface protocol determines which device is allowed to drive  $S_{DATA}$  at any given time.

The protocols described in the two-wire serial interface specification allow the slave device to drive  $S_{CLK}$  LOW; the AR0234CS uses  $S_{CLK}$  as an input only and therefore never drives it LOW.

### Protocol

Data transfers on the two-wire serial interface bus are performed by a sequence of low-level protocol elements:

- a (repeated) start condition
- a slave address/data direction byte
- an (a no) acknowledge bit
- a message byte
- a stop condition

The bus is idle when both  $S_{CLK}$  and  $S_{DATA}$  are HIGH. Control of the bus is initiated with a start condition, and the bus is released with a stop condition. Only the master can generate the start and stop conditions.

#### Start Condition

A start condition is defined as a HIGH-to-LOW transition on  $S_{DATA}$  while  $S_{CLK}$  is HIGH. At the end of a transfer, the master can generate a start condition without previously generating a stop condition; this is known as a “repeated start” or “restart” condition.

#### Stop Condition

A stop condition is defined as a LOW-to-HIGH transition on  $S_{DATA}$  while  $S_{CLK}$  is HIGH.

#### Data Transfer

Data is transferred serially, 8 bits at a time, with the MSB transmitted first. Each byte of data is followed by an acknowledge bit or a no-acknowledge bit. This data transfer mechanism is used for the slave address/data direction byte and for message bytes.

One data bit is transferred during each  $S_{CLK}$  clock period.  $S_{DATA}$  can change when  $S_{CLK}$  is LOW and must be stable while  $S_{CLK}$  is HIGH.

#### Slave Address/Data Direction Byte

Bits [7:1] of this byte represent the device slave address and bit [0] indicates the data transfer direction. A “0” in

bit [0] indicates a WRITE, and a “1” indicates a READ. The default slave addresses used by the AR0234CS are 0x20 (write address) and 0x21 (read address) in accordance with the specification. Alternate slave addresses of 0x30 (write address) and 0x31 (read address) can be selected by enabling and asserting the  $S_{ADDR}$  input.

An alternate slave address can also be programmed through R0x31FC.

#### Message Byte

Message bytes are used for sending register addresses and register write data to the slave device and for retrieving register read data.

#### Acknowledge Bit

Each 8-bit data transfer is followed by an acknowledge bit or a no-acknowledge bit in the  $S_{CLK}$  clock period following the data transfer. The transmitter (which is the master when writing, or the slave when reading) releases  $S_{DATA}$ . The receiver indicates an acknowledge bit by driving  $S_{DATA}$  LOW. As for data transfers,  $S_{DATA}$  can change when  $S_{CLK}$  is LOW and must be stable while  $S_{CLK}$  is HIGH.

#### No-Acknowledge Bit

The no-acknowledge bit is generated when the receiver does not drive  $S_{DATA}$  LOW during the  $S_{CLK}$  clock period following a data transfer. A no-acknowledge bit is used to terminate a read sequence.

### Typical Sequence

A typical READ or WRITE sequence begins by the master generating a start condition on the bus. After the start condition, the master sends the 8-bit slave address/data direction byte. The last bit indicates whether the request is for a read or a write, where a “0” indicates a write and a “1” indicates a read. If the address matches the address of the slave device, the slave device acknowledges receipt of the address by generating an acknowledge bit on the bus.

If the request was a WRITE, the master then transfers the 16-bit register address to which the WRITE should take place. This transfer takes place as two 8-bit sequences and the slave sends an acknowledge bit after each sequence to indicate that the byte has been received. The master then transfers the data as an 8-bit sequence; the slave sends an acknowledge bit at the end of the sequence. The master stops writing by generating a (re)start or stop condition.

If the request was a READ, the master sends the 8-bit write slave address/data direction byte and 16-bit register address, the same way as with a WRITE request. The master then generates a (re)start condition and the 8-bit read slave address/data direction byte, and clocks out the register data, eight bits at a time. The master generates an acknowledge bit after each 8-bit transfer. The slave’s internal register address is automatically incremented after every 8 bits are transferred. The data transfer is stopped when the master sends a no-acknowledge bit.

**Single READ from Random Location**

This sequence (Figure 7) starts with a dummy WRITE to the 16-bit address that is to be used for the READ. The master terminates the WRITE by generating a restart condition. The master then sends the 8-bit read slave address/data direction byte and clocks out one byte of

register data. The master terminates the READ by generating a no-acknowledge bit followed by a stop condition. Figure 7 shows how the internal register address maintained by the AR0234CS is loaded and incremented as the sequence proceeds.

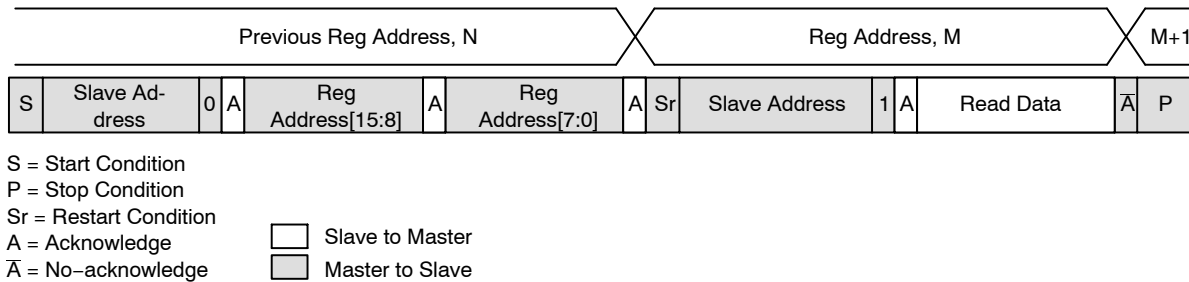
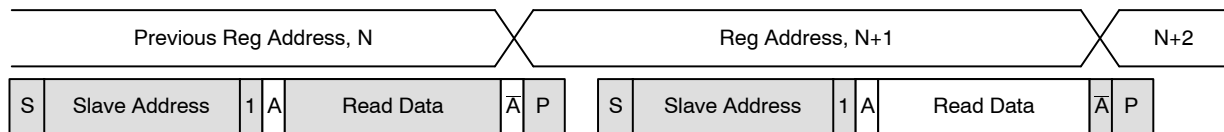

**Figure 7. Single READ from Random Location**

**Single READ from Current Location**

This sequence (Figure 8) performs a read using the current value of the AR0234CS internal register address.

The master terminates the READ by generating a no-acknowledge bit followed by a stop condition. The figure shows two independent READ sequences.

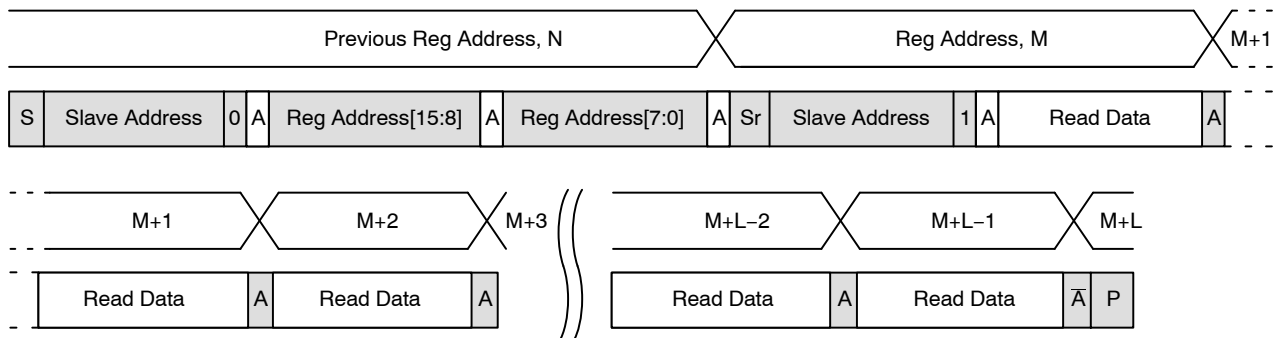

**Figure 8. Single READ from Current Location**

**Sequential READ, Start from Random Location**

This sequence (Figure 9) starts in the same way as the single READ from random location (Figure 7). Instead of generating a no-acknowledge bit after the first byte of data

has been transferred, the master generates an acknowledge bit and continues to perform byte READs until “L” bytes have been read.



**Figure 9. Sequential READ, Start from Random Location**

**Sequential READ, Start from Current Location**

This sequence (Figure 10) starts in the same way as the single READ from current location (Figure 8). Instead of generating a no-acknowledge bit after the first byte of data

has been transferred, the master generates an acknowledge bit and continues to perform byte READs until “L” bytes have been read.

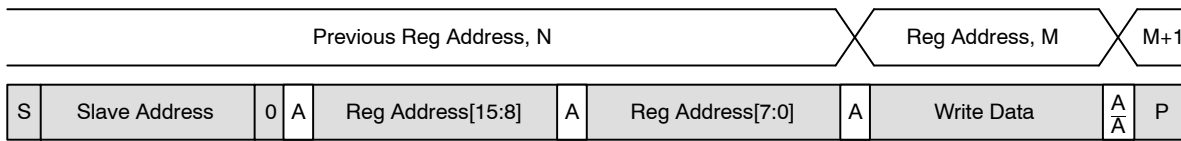

**Figure 10. Sequential READ, Start from Current Location**

**Single WRITE to Random Location**

This sequence (Figure 11) begins with the master generating a start condition. The slave address/data direction byte signals a WRITE and is followed by the HIGH

then LOW bytes of the register address that is to be written. The master follows this with the byte of write data. The WRITE is terminated by the master generating a stop condition.

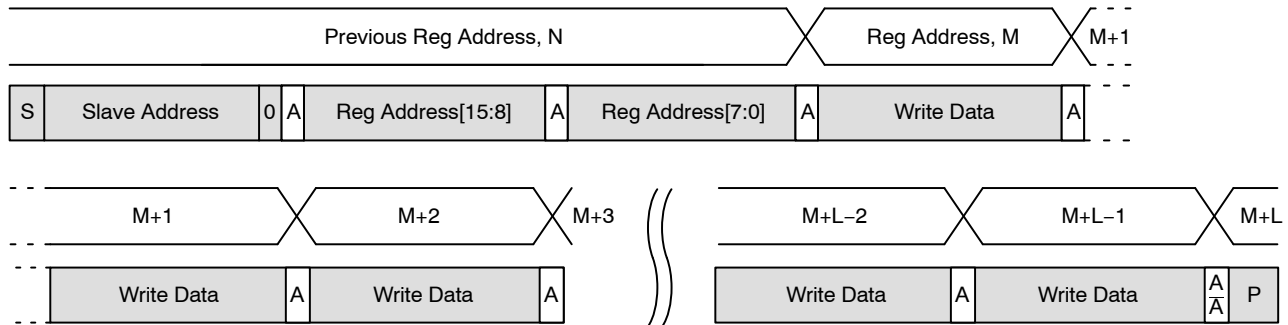

**Figure 11. Single WRITE to Random Location**

**Sequential WRITE, Start at Random Location**

This sequence (Figure 12) starts in the same way as the single WRITE to random location (Figure 11). Instead of generating a no-acknowledge bit after the first byte of data

has been transferred, the master generates an acknowledge bit and continues to perform byte WRITES until “L” bytes have been written. The WRITE is terminated by the master generating a stop condition.



**Figure 12. Sequential WRITE, Start at Random Location**

**ELECTRICAL SPECIFICATIONS**

Unless otherwise stated, the following specifications apply to the following conditions:

$V_{DD} = V_{DD\_PHY} = V_{DD\_DATA} = 1.2 \text{ V} \pm 0.06$ ;  
 $V_{DD\_IO} = V_{AA} = V_{AA\_PIX} = 2.8 \text{ V} \pm 0.3 \text{ V}$ ;  $V_{DDIO\_PHY} = 1.8 \text{ V} \pm 0.1 \text{ V}$   
 $T_A = -40^\circ\text{C}$  to  $+85^\circ\text{C}$ ;  
 Output Load = 10 pF;  
 PIXCLK Frequency = 90 MHz;  
 MIPI off.

**Two-Wire Serial Register Interface**

The electrical characteristics of the two-wire serial register interface ( $S_{CLK}$ ,  $S_{DATA}$ ) are shown in Figure 13 and Table 6.

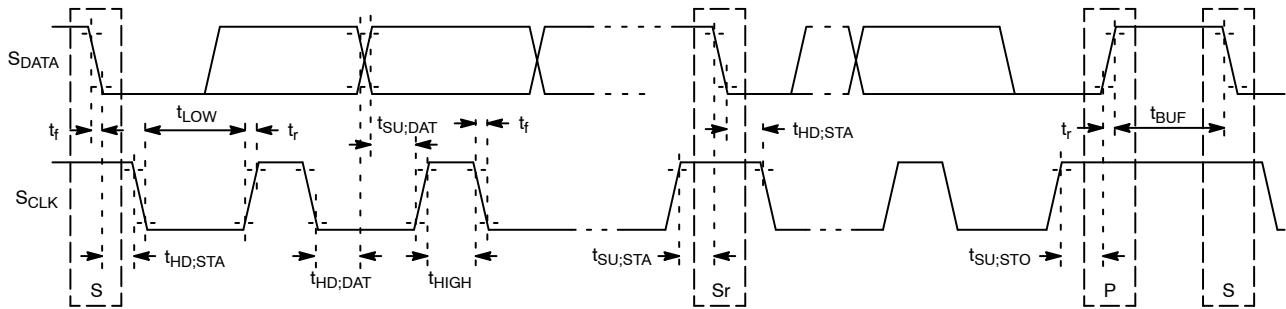

NOTE: Read sequence: For an 8-bit READ, read waveforms start after WRITE command and register address are issued.

**Figure 13. Two-Wire Serial Bus Timing Parameters**

**Table 6. TWO-WIRE SERIAL BUS CHARACTERISTICS**

( $f_{EXTCLK} = 27 \text{ MHz}$ ;  $V_{DD} = 1.2 \text{ V}$ ;  $V_{DD\_IO} = 2.8 \text{ V}$ ;  $V_{AA} = 2.8 \text{ V}$ ;  $V_{AA\_PIX} = 2.8 \text{ V}$ ;  $V_{DD\_PHY} = 1.2 \text{ V}$ ;  $V_{DDIO\_PHY} = 1.8 \text{ V}$ ;  $T_A = 25^\circ\text{C}$ )

Parameter	Symbol	Standard Mode		Fast-Mode		Unit
		Min	Max	Min	Max	
$S_{CLK}$ Clock Frequency	$f_{SCL}$	0	100	0	400	kHz
Hold Time (Repeated) START Condition (After This Period, the First Clock Pulse is Generated)	$t_{HD;STA}$	4.0	–	0.6	–	$\mu\text{s}$
LOW Period of the $S_{CLK}$ Clock	$t_{LOW}$	4.7	–	1.3	–	$\mu\text{s}$
HIGH Period of the $S_{CLK}$ Clock	$t_{HIGH}$	4.0	–	0.6	–	$\mu\text{s}$
Set-up Time for a Repeated START Condition	$t_{SU;STA}$	4.7	–	0.6	–	$\mu\text{s}$
Data Hold Time	$t_{HD;DAT}$	0 (Note 4)	3.45 (Note 5)	0 (Note 6)	0.9 (Note 5)	$\mu\text{s}$
Data Set-up Time	$t_{SU;DAT}$	250	–	100 (Note 6)	–	ns
Rise Time of both $S_{DATA}$ and $S_{CLK}$ Signals	$t_r$	–	1000	$20 + 0.1C_b$ (Note 7)	300	ns
Fall Time of both $S_{DATA}$ and $S_{CLK}$ Signals	$t_f$	–	300	$20 + 0.1C_b$ (Note 7)	300	ns
Set-up Time for STOP Condition	$t_{SU;STO}$	4.0	–	0.6	–	$\mu\text{s}$
Bus Free Time between a STOP and START Condition	$t_{BUF}$	4.7	–	1.3	–	$\mu\text{s}$
Capacitive Load for each Bus Line	$C_b$	–	400	–	400	pF

**Table 6. TWO-WIRE SERIAL BUS CHARACTERISTICS** (continued)

( $f_{EXTCLK} = 27 \text{ MHz}$ ;  $V_{DD} = 1.2 \text{ V}$ ;  $V_{DD\_IO} = 2.8 \text{ V}$ ;  $V_{AA} = 2.8 \text{ V}$ ;  $V_{AA\_PIX} = 2.8 \text{ V}$ ;  $V_{DD\_PHY} = 1.2 \text{ V}$ ;  $V_{DDIO\_PHY} = 1.8 \text{ V}$ ;  $T_A = 25^\circ\text{C}$ )

Parameter	Symbol	Standard Mode		Fast-Mode		Unit
		Min	Max	Min	Max	
Serial Interface Input Pin Capacitance	CIN_SI	-	3.3	-	3.3	pF
S <sub>DATA</sub> Max Load Capacitance	CLOAD_SD	-	30	-	30	pF
S <sub>DATA</sub> Pull-up Resistor	RSD	1.5	4.7	1.5	4.7	kΩ

1. This table is based on I<sup>2</sup>C standard (v2.1 January 2000). Philips Semiconductor.
2. Two-wire control is I<sup>2</sup>C-compatible.
3. All values referred to  $V_{IHmin} = 0.9 V_{DD\_IO}$  and  $V_{ILmax} = 0.1 V_{DD\_IO}$  levels. Sensor EXCLK = 27 MHz.
4. A device must internally provide a hold time of at least 300 ns for the S<sub>DATA</sub> signal to bridge the undefined region of the falling edge of SCLK. The two-wire standard specifies a minimum rise and fall time for Fast-Mode operation. This specification is not a timing requirement that is enforced on ON Semiconductor sensor's as a receiver, because our receivers are designed to work in mixed systems with std-mode where no such minimum rise and fall times are required/specified. However, it's the host's responsibility when using fast edge rates, especially when two-wire slew-rate driver control isn't available, to manage the generated EMI, and the potential voltage undershoot on the sensor receiver circuitry, to avoid activating sensor ESD diodes and current-clamping circuits. This is typically not an issue in most applications, but should be checked if below minimum fall times and rise times are required. A device must internally provide a hold time of at least 300 ns for the S<sub>DATA</sub> signal to bridge the undefined region of the falling edge of SCLK.
5. The maximum  $t_{HD:DAT}$  has only to be met if the device does not stretch the LOW period ( $t_{LOW}$ ) of the SCLK signal.
6. A Fast-mode I<sup>2</sup>C-bus device can be used in a Standard-mode I<sup>2</sup>C-bus system, but the requirement  $t_{SU:DAT}$  250 ns must then be met. This will automatically be the case if the device does not stretch the LOW period of the SCLK signal. If such a device does stretch the LOW period of the SCLK signal, it must output the next data bit to the S<sub>DATA</sub> line  $t_r \text{ max} + t_{SU:DAT} = 1000 + 250 = 1250 \text{ ns}$  (according to the Standard-mode I<sup>2</sup>C-bus specification) before the SCLK line is released.
7. C<sub>b</sub> = total capacitance of one bus line in pF.

**I/O Timing**

By default, the AR0234CS launches pixel data, FV and LV with the falling edge of PIXCLK. The expectation is that the user captures D<sub>OUT</sub>[9:0], FV and LV using the rising

edge of PIXCLK. The launch edge of PIXCLK can be configured in register R0x3028. See Figure 14 and Table 7 for I/O timing (AC) characteristics.

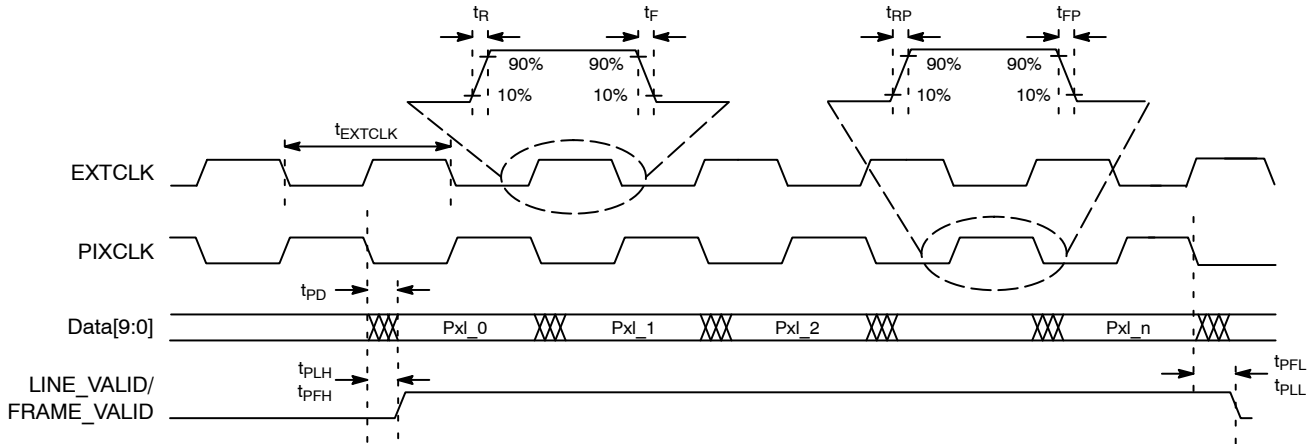

**Figure 14. I/O Timing Diagram**

**Table 7. I/O TIMING CHARACTERISTICS, PARALLEL OUTPUT (1.8 V V<sub>DD\_IO</sub>)** (Note 8)

Symbol	Definition	Condition	Min	Typ	Max	Unit
f <sub>EXTCLK</sub>	Input Clock Frequency		6	–	54	MHz
t <sub>EXTCLK</sub>	Input Clock Period		18.5	–	166.7	ns
t <sub>R</sub>	Input Clock Rise Time	PLL Enabled	–	3	–	ns
t <sub>F</sub>	Input Clock Fall Time	PLL Enabled	–	3	–	ns
t <sub>JITTER</sub>	Input Clock Jitter		–	–	600	ns
t <sub>cp</sub>	EXTCLK to PIXCLK Propagation Delay	Nominal Voltages, PLL Disabled, PIXCLK Slew Rate = 4	9	–	106	ns
t <sub>RP</sub>	PIXCLK Rise Time	PCLK Slew Rate = 6	2.1	–	4.2	ns
t <sub>FP</sub>	PIXCLK Fall Time	PCLK Slew Rate = 6	1	–	2.7	ns
	PIXCLK Duty Cycle		30	–	55	%
f <sub>PIXCLK</sub>	PIXCLK Frequency	PIXCLK Slew Rate = 6, Data Slew Rate = 7	6	–	90	MHz
t <sub>PD</sub>	PIXCLK to Data Valid	PIXCLK Slew Rate = 6, Data Slew Rate = 7	2.5	–	3.6	ns
t <sub>PFH</sub>	PIXCLK to FV HIGH	PIXCLK Slew Rate = 6, Data Slew Rate = 7	2.5	–	3.0	ns
t <sub>PLH</sub>	PIXCLK to LV HIGH	PIXCLK Slew Rate = 6, Data Slew Rate = 7	2.2	–	3.0	ns
t <sub>PFL</sub>	PIXCLK to FV LOW	PIXCLK Slew Rate = 6, Data Slew Rate = 7	0.5	–	1.2	ns
t <sub>PLL</sub>	PIXCLK to LV LOW	PIXCLK Slew Rate = 6, Data Slew Rate = 7	0.2	–	0.7	ns
C <sub>IN</sub>	Input Pin Capacitance		–	2.5	–	pF

8. Minimum and maximum values are taken at 85°C ambient, 1.7 V and –40°C ambient, 1.9 V. All values are taken at the 50% transition point. The loading used is 10 pF.

9. Jitter from PIXCLK is already taken into account in the data for all of the output parameters.

**Table 8. I/O TIMING CHARACTERISTICS, PARALLEL OUTPUT (2.8 V V<sub>DD\_IO</sub>)** (Note 10)

Symbol	Definition	Condition	Min	Typ	Max	Unit
f <sub>EXTCLK</sub>	Input Clock Frequency		6	–	54	MHz
t <sub>EXTCLK</sub>	Input Clock Period		18.5	–	166.7	ns
t <sub>R</sub>	Input Clock Rise Time	PLL Enabled	–	3	–	ns
t <sub>F</sub>	Input Clock Fall Time	PLL Enabled	–	3	–	ns
t <sub>JITTER</sub>	Input Clock Jitter	Nominal Voltages, PLL Disabled, PIXCLK Slew Rate = 4	–	–	600	ns
t <sub>cp</sub>	EXTCLK to PIXCLK Propagation Delay	Nominal Voltages, PLL Disabled, PIXCLK Slew Rate = 4	4.3	–	105	ns
t <sub>RP</sub>	PIXCLK Rise Time	PCLK Slew Rate = 6	0.9	–	2.3	ns
t <sub>FP</sub>	PIXCLK Fall Time	PCLK slew rate = 6	0.5	–	1.5	ns
	PIXCLK Duty Cycle		40	–	55	%
f <sub>PIXCLK</sub>	PIXCLK Frequency	PIXCLK Slew Rate = 6, Data Slew Rate = 7	6	–	90	MHz
t <sub>PD</sub>	PIXCLK to Data Valid	PIXCLK Slew Rate = 6, Data Slew Rate = 7	2.2	–	3.1	ns
t <sub>PFH</sub>	PIXCLK to FV HIGH	PIXCLK Slew Rate = 6, Data Slew Rate = 7	1.7	–	2.4	ns
t <sub>PLH</sub>	PIXCLK to LV HIGH	PIXCLK Slew Rate = 6, Data Slew Rate = 7	1.7	–	2.3	ns
t <sub>PFL</sub>	PIXCLK to FV LOW	PIXCLK Slew Rate = 6, Data Slew Rate = 7	0.8	–	1.1	ns
t <sub>PLL</sub>	PIXCLK to LV LOW	PIXCLK Slew Rate = 6, Data Slew Rate = 7	0.4	–	0.9	ns
C <sub>IN</sub>	Input Pin Capacitance		–	2.5	–	pF

10. Minimum and maximum values are taken at 85°C ambient, 2.5 V and –40°C ambient, 3.1 V. All values are taken at the 50% transition point. The loading used is 10 pF.

11. Jitter from PIXCLK is already taken into account in the data for all of the output parameters.

**Table 9. I/O RISE SLEW RATE (2.8 V  $V_{DD\_IO}$ )** (Note 12)

Parallel Slew (R0x306E[15:13])	Min	Typ	Max	Unit
0	0.39		0.91	V/ns
1	0.49		1.85	V/ns
2	0.54		2.14	V/ns
3	0.64		2.30	V/ns
4	0.80		2.45	V/ns
5	1.00		2.79	V/ns
6	1.13		3.06	V/ns
7	1.27		3.33	V/ns

12. Minimum and maximum values are taken at 85°C ambient, 2.5 V and -40°C junction, 3.1 V. The loading used is 10 pF.

**Table 10. I/O FALL SLEW RATE (2.8 V  $V_{DD\_IO}$ )** (Note 13)

Parallel Slew (R0x306E[15:13])	Min	Typ	Max	Unit
0	0.37		2.66	V/ns
1	0.54		3.15	V/ns
2	0.67		3.52	V/ns
3	1.25		3.90	V/ns
4	1.55		4.03	V/ns
5	1.77		4.15	V/ns
6	1.94		4.21	V/ns
7	2.07		4.21	V/ns

13. Minimum and maximum values are taken at 85°C ambient, 2.5 V and -40°C ambient, 3.1 V. The loading used is 10 pF.

**Table 11. I/O RISE SLEW RATE (1.8 V  $V_{DD\_IO}$ )** (Note 14)

Parallel Slew (R0x306E[15:13])	Min	Typ	Max	Unit
0	0.19		0.31	V/ns
1	0.22		0.33	V/ns
2	0.24		0.38	V/ns
3	0.27		0.64	V/ns
4	0.29		0.76	V/ns
5	0.32		0.85	V/ns
6	0.34		0.91	V/ns
7	0.37		0.97	V/ns

14. Minimum and maximum values are taken at 85°C ambient, 1.7 V and -40°C junction, 1.9 V. The loading used is 10 pF.

**Table 12. I/O FALL SLEW RATE (1.8 V  $V_{DD\_IO}$ )** (Note 15)

Parallel Slew (R0x306E[15:13])	Min	Typ	Max	Unit
0	0.17		0.32	V/ns
1	0.23		0.61	V/ns
2	0.29		1.13	V/ns
3	0.32		1.39	V/ns
4	0.37		1.55	V/ns
5	0.43		1.69	V/ns
6	0.50		1.80	V/ns
7	0.61		1.99	V/ns

15. Minimum and maximum values are taken at 85°C ambient, 1.7 V and -40°C ambient, 1.9 V. The loading used is 10 pF.



**DC Electrical Characteristics**

The DC electrical characteristics are shown in Table 13, Table 14, Table 15, and Table 16.

**Table 13. DC ELECTRICAL CHARACTERISTICS**

Symbol	Definition	Condition	Min	Typ	Max	Slew Rate	Unit
V <sub>DD</sub>	Core Digital Voltage		1.14	1.2	1.26		V
V <sub>DD_IO</sub>	I/O Digital Voltage		1.7/2.5	1.8/2.8	1.9/3.1		V
V <sub>DD_IO_PHY</sub>	I/O Power Supply		1.7	1.8	1.9		V
V <sub>AA</sub>	Analog Voltage		2.5	2.8	3.1		V
V <sub>AA_PIX</sub>	Pixel Supply Voltage		2.5	2.8	3.1		V
V <sub>DD_PHY</sub>	MIPI Supply Voltage		1.14	1.2	1.26		V
V <sub>DD_DATA</sub>	MIPI Supply Voltage		1.14	1.2	1.26		V
V <sub>AA_PHY</sub>	MIPI Supply Voltage		2.5	2.8	3.1		V
V <sub>IH</sub>	Input HIGH Voltage		V <sub>DD_IO</sub> * 0.7	–	–		V
V <sub>IL</sub>	Input LOW Voltage		–	–	V <sub>DD_IO</sub> * 0.3		V
I <sub>IN</sub>	Input Leakage Current	No Pull-up Resistor; V <sub>IN</sub> = V <sub>DD_IO</sub> or DGND		–	20		µA
V <sub>OH</sub>	Output HIGH Voltage		V <sub>DD_IO</sub> * 0.7 (1.8/2.8)	–	–	0	V
V <sub>OH</sub>	Output HIGH Voltage		V <sub>DD_IO</sub> * 0.7 (1.8/2.8)	–	–	7	V
V <sub>OL</sub>	Output LOW Voltage		–	–	0.4 (1.8 V/2.8 V)	0	V
V <sub>OL</sub>	Output LOW Voltage		–	–	0.4 (1.8 V/2.8 V)	7	V
I <sub>OH</sub>	Output HIGH Current	At Specified V <sub>OH</sub>	–	–	3 (1.8 V/2.8 V)	0	mA
I <sub>OH</sub>	Output HIGH Current	At Specified V <sub>OH</sub>	–	–	7 (1.8 V) 12(2.8 V)	7	mA
I <sub>OL</sub>	Output LOW Current	At Specified V <sub>OL</sub>	–	–	2 (1.8 V) 3(2.8 V)	0	mA
I <sub>OL</sub>	Output LOW Current	At Specified V <sub>OL</sub>	–	–	7 (1.8 V) 9(2.8 V)	7	mA

**CAUTION:** Stresses greater than those listed in Table 14 may cause permanent damage to the device. This is a stress rating only, and functional operation of the device at these or any other conditions above those indicated in the operational sections of this specification is not implied.

**Table 14. ABSOLUTE MAXIMUM RATINGS**

Symbol	Parameter	Min	Max	Unit
V <sub>SUPPLY</sub>	Power Supply Voltage (All Supplies)	–0.3	4.5	V
I <sub>SUPPLY</sub>	Total Power Supply Current	–	400	mA
I <sub>GND</sub>	Total Ground Current	–	400	mA
V <sub>IN</sub>	DC Input Voltage	–0.3	V <sub>DD_IO</sub> + 0.3	V
V <sub>OUT</sub>	DC Output Voltage	–0.3	V <sub>DD_IO</sub> + 0.3	V
T <sub>STG</sub>	Storage Temperature (Note 16)	–40	+125	°C

Stresses exceeding those listed in the Maximum Ratings table may damage the device. If any of these limits are exceeded, device functionality should not be assumed, damage may occur and reliability may be affected.

16. Exposure to absolute maximum rating conditions for extended periods may affect reliability.

**Table 15. OPERATING CURRENT CONSUMPTION FOR PARALLEL OUTPUT**

( $V_{AA} = V_{AA\_PIX} = V_{DD\_IO} = V_{AA\_PHY} = 2.8\text{ V}$ ;  $V_{DD} = V_{DD\_PHY} = V_{DD\_DATA} = 1.2\text{ V}$ ;  $V_{DDIO\_PHY} = 1.8\text{ V}$ ; PLL Enabled and PIXCLK = 90 MHz;  $T_A = 25^\circ\text{C}$ ;  $C_{LOAD} = 10\text{ pF}$ )

Symbol	Parameter	Condition	Min	Typ	Max	Unit
IDD_PHY + IDD_DATA + IDD	Digital Operating Current	Parallel, Streaming, Full Resolution 30 fps	–	52	105	mA
IDD_IO	I/O Digital Operating Current	Parallel, Streaming, Full Resolution 30 fps	–	40	112	mA
IDDIO_PHY	I/O PHY Digital Operating Current	Parallel, Streaming, Full Resolution 30 fps	–	0	1	mA
IAA_PHY + IAA	Analog Operating Current	Parallel, Streaming, Full Resolution 30 fps	–	50	90	mA
IAA_PIX	Pixel Supply Current	Parallel, Streaming, Full Resolution 30 fps	–	5	13	mA

17. Values in Table 15 are subject to change.

18. Maximum values for  $V_{DD\_IO}$  parallel are dependent on the specific load being applied in the final design. Typical values are based on a load of 20 pF.

19. The following supply rails can be connected together.

1.  $V_{DD}$ ,  $V_{DD\_PHY}$  and  $V_{DD\_DATA}$
2.  $V_{DD\_IO}$  and  $V_{DDIO\_PHY}$  if 1.8 VDC each
3.  $V_{AA}$ ,  $V_{AA\_PHY}$  and  $V_{AA\_PIX}$

**Table 16. OPERATING CURRENT CONSUMPTION FOR MIPI OUTPUT**

( $V_{AA} = V_{AA\_PIX} = V_{DD\_IO} = V_{AA\_PHY} = 2.8\text{ V}$ ;  $V_{DD} = V_{DD\_PHY} = V_{DD\_DATA} = 1.2\text{ V}$ ;  $V_{DDIO\_PHY} = 1.8\text{ V}$ ; PLL Enabled and PIXCLK = 90 MHz;  $T_A = 25^\circ\text{C}$ ;  $C_{LOAD} = 10\text{ pF}$ )

Symbol	Parameter	Condition	Min	Typ	Max	Unit
IDD_PHY + IDD_DATA + IDD	Digital Operating Current	MIPI, Streaming, Full Resolution 120 fps	–	155	250	mA
IDD_IO	I/O Digital Operating Current	MIPI, Streaming, Full Resolution 120 fps	–	0.2	1	mA
IDDIO_PHY	I/O PHY Digital Operating Current	MIPI, Streaming, Full Resolution 120 fps	–	10	12	mA
IAA_PHY + IAA	Analog Operating Current	MIPI, Streaming, Full Resolution 120 fps	–	55	102	mA
IAA_PIX	Pixel Supply Current	MIPI, Streaming, Full Resolution 120 fps	–	5	13	mA

20. Values in Table 16 are subject to change.

21. The following supply rails can be connected together.

1.  $V_{DD}$ ,  $V_{DD\_PHY}$  and  $V_{DD\_DATA}$
2.  $V_{DD\_IO}$  and  $V_{DDIO\_PHY}$  if 1.8 VDC each
3.  $V_{AA}$ ,  $V_{AA\_PHY}$  and  $V_{AA\_PIX}$

**Table 17. STANDBY CURRENT CONSUMPTION**

(Analog =  $V_{AA} + V_{AA\_PIX} + V_{AA\_PHY}$ ; Digital =  $V_{DD} + V_{DD\_IO} + V_{DD\_PHY} + V_{DDIO\_PHY} + V_{DD\_DATA}$ ;  $T_A = 25^\circ\text{C}$ )

Definition	Condition	Min	Typ	MAX	Unit
Soft Standby (Clock Off, Driven Low)	Analog, 2.8 V	–	5	300	$\mu\text{A}$
	Digital, 1.2 V/1.8 V/2.8 V	–	250	4000	$\mu\text{A}$
Soft Standby (Clock On, EXTCLK = 27 MHz)	Analog, 2.8 V	–	5	300	$\mu\text{A}$
	Digital, 1.2 V/1.8 V/2.8 V	–	5000	14000	$\mu\text{A}$
nRESET Low (Clk off)	Analog, 2.8 V	–	5	300	$\mu\text{A}$
	Digital, 1.2 V/1.8 V/2.8 V	–	250	4000	$\mu\text{A}$
nRESET Low	Analog, 2.8V	–	5	300	$\mu\text{A}$
	Digital, 1.2 V/1.8 V/2.8 V	–	250	4000	$\mu\text{A}$

22. Values in Table 17 are subject to change.

**MIPI Electrical Specifications**

The ON Semiconductor AR0234CS sensor supports four lanes of MIPI data.

Compliant to MIPI standards:

- MIPI Alliance Standard for CSI-2 version 1.2
- MIPI Alliance Standard for D-PHY version 1.2

**MIPI AC and DC Electrical Characteristics****Table 18. MIPI HIGH-SPEED TRANSMITTER DC CHARACTERISTICS**

Symbol	Parameter	Min	Typ	Max	Unit
$V_{OD}$	HS transmit differential voltage	140	–	270	mV
$V_{CMTX}$	HS transmit static common mode voltage	150	–	250	mV
$\Delta V_{OD}$	$V_{OD}$ mismatch when output is Differential-1 or Differential-0	–	–	14	mV
$\Delta V_{CMTX(1,0)}$	$V_{CMTX}$ mismatch when output is Differential-1 or Differential-0	–	–	5	mV
$V_{OHHS}$	HS output HIGH voltage	–	–	360	mV
$Z_{OS}$	Single-ended output impedance	40	–	62.5	$\Omega$
$\Delta Z_{OS}$	Single-ended output impedance mismatch	–	–	20	%

**Table 19. MIPI HIGH-SPEED TRANSMITTER AC CHARACTERISTICS**

Symbol	Parameter	Min	Typ	Max	Unit
	Data bit rate	–	–	900	Mb/s
$t_{rise}$	20–80% rise time	150	–	333	ps
$t_{fall}$	20–80% fall time	150	–	333	ps

**Table 20. MIPI LOW-POWER TRANSMITTER DC CHARACTERISTICS**

Symbol	Parameter	Min	Typ	Max	Unit
$V_{OL}$	Thevenin output low level	–	–	50	mV
$V_{OH}$	Thevenin output high level	1.1	1.15	1.3	V
$Z_{OLP}$	Output impedance of LP transmitter	110	–	–	

**Table 21. MIPI LOW-POWER TRANSMITTER AC CHARACTERISTICS**

Symbol	Parameter	Min	Typ	Max	Unit
$t_{rise}$	15–85% rise time	–	–	25	ns
$t_{fall}$	15–85% fall time	–	–	25	ns
Slew	Slew rate ( $C_{LOAD}$ 5–20 pf)	–	–	250	mV/ns
Slew	Slew rate ( $C_{LOAD}$ 20–70 pf)	–	–	150	mV/ns

**POWER-ON RESET AND STANDBY TIMING**

**Power-Up Sequence**

The recommended power-up sequence for the AR0234 is shown in Figure 15. The available power supplies ( $V_{AA}/V_{AA\_PIX}/V_{AA\_PHY}$ ,  $V_{DDIO}$ ,  $V_{DDIO\_PHY}$ ,  $V_{DD}/V_{DD\_PHY}$ , and  $V_{DD\_DATA}$ ) must have the separation specified below.

1. Turn on  $V_{AA}/V_{AA\_PIX}/V_{AA\_PHY}$  power supply.
2. After 0–100  $\mu$ s, turn on  $V_{DDIO}$  power supply.
3. After 0–100  $\mu$ s, turn on  $V_{DDIO\_PHY}(1.8\text{ V})$  power supply.
4. After 0–100  $\mu$ s, turn on  $V_{DD}/V_{DD\_PHY}$  power supply
5. After 0–100  $\mu$ s, turn on  $V_{DD\_DATA}$  power supply.

6. After the last power supply is stable, enable EXTCLK.
7. Assert RESET\_N for at least 1 ms. The parallel interface will be tri-stated during this time.
8. Wait for ~160000 EXTCLKs for internal initialization into soft standby where M3ROM and full OTPM upload would be complete.
9. Set streaming mode (mode\_select/stream (R0x301A[2]) = 1) and the internal PLL would be enabled (not locked yet).
10. Wait for 1 ms for PLL lock to complete, Part will then go into streaming mode.

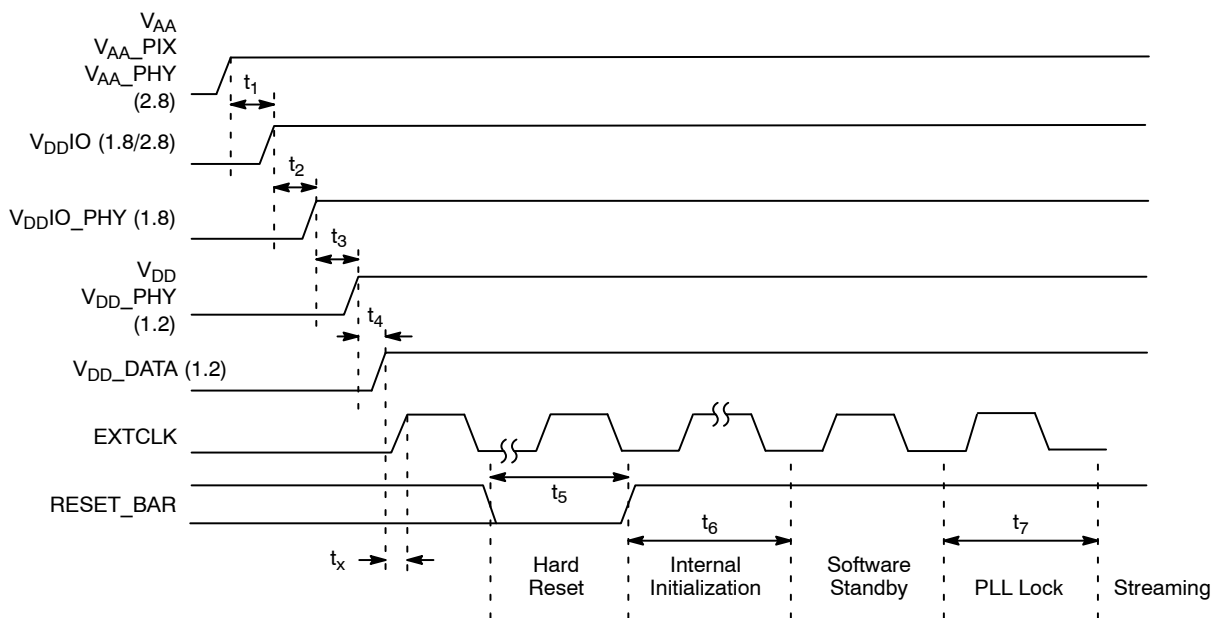

**Figure 15. Power-up Sequence**

**Table 22. POWER-UP SEQUENCE**

SN	Definition	Symbol	Min	Typ	Max	Unit
1	$V_{AA}/V_{AA\_PIX}/V_{AA\_PHY}$ to $V_{DDIO}$	$t_1$	0	100	–	$\mu$ s
2	$V_{DDIO}$ to $V_{DDIO\_PHY}$	$t_2$	0	100	–	$\mu$ s
3	$V_{DDIO\_PHY}$ to $V_{DD}/V_{DD\_PHY}$	$t_3$	0	100	–	$\mu$ s
4	$V_{DD}/V_{DD\_PHY}$ to $V_{DD\_DATA}$	$t_4$	0	100	–	$\mu$ s
5	Xtal Settle Time (Component Dependent)	$t_x$	–	30	–	ms
6	Hard Reset	$t_5$	1	–	–	ms
7	Internal Initialization	$t_6$	160000	–	–	EXTCLK
8	PLL Lock Time	$t_7$	1	–	–	ms

23.  $V_{DD}$  and  $V_{DD\_DATA}$  can be tied together ( $t_4$  becomes '0' in this case).

24.  $V_{AA}/V_{AA\_PIX}/V_{AA\_PHY}$  can be tied together.

**Power Down Sequence**

The recommended power-down sequence for the AR0234 is shown in Figure 16. The available power supplies ( $V_{AA}/V_{AA\_PIX}/V_{AA\_PHY}$ ,  $V_{DDIO}$ ,  $V_{DDIO\_PHY}$ ,  $V_{DD}/V_{DD\_PHY}$ , and  $V_{DD\_DATA}$ ) must have the separation specified below.

1. Disable streaming if output is active by setting standby  $R0x301a[2] = 0$ .
2. The soft standby state is reached after the current row or frame, depending on configuration, has ended.

3. Turn off  $V_{DD\_DATA}$ .
4. Turn off  $V_{DD}/V_{DD\_PHY}$ .
5. Turn off  $V_{DDIO\_PHY}$ .
6. Turn off  $V_{DDIO}$ .
7. Turn off  $V_{AA}/V_{AA\_PIX}/V_{AA\_PHY}$ .

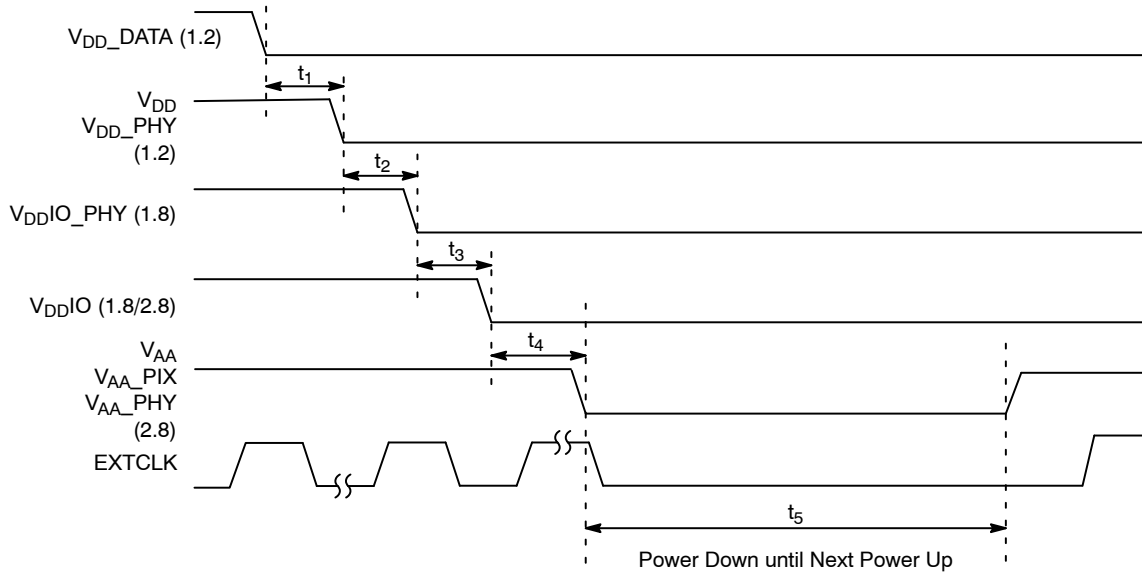

**Figure 16. Power-down Sequence**

**Table 23. POWER-DOWN SEQUENCE**

SN	Definition	Symbol	Min	Typ	Max	Unit
1	$V_{DD\_DATA}$ to $V_{DD}/V_{DD\_PHY}$	$t_1$	0	-	-	
2	$V_{DD}/V_{DD\_PHY}$ to $V_{DDIO\_PHY}$	$t_2$	0	-	-	
3	$V_{DDIO\_PHY}$ to $V_{DDIO}$	$t_3$	0	-	-	
4	$V_{DDIO}$ to $V_{AA}/V_{AA\_PIX}/V_{AA\_PHY}$	$t_4$	0	-	-	
5	PwrDn until Next Pwrup Time	$t_5$	100	-	-	ms

25.  $V_{DD}$  and  $V_{DD\_DATA}$  can be tied together.  
26.  $V_{AA}/V_{AA\_PIX}/V_{AA\_PHY}$  can be tied together.

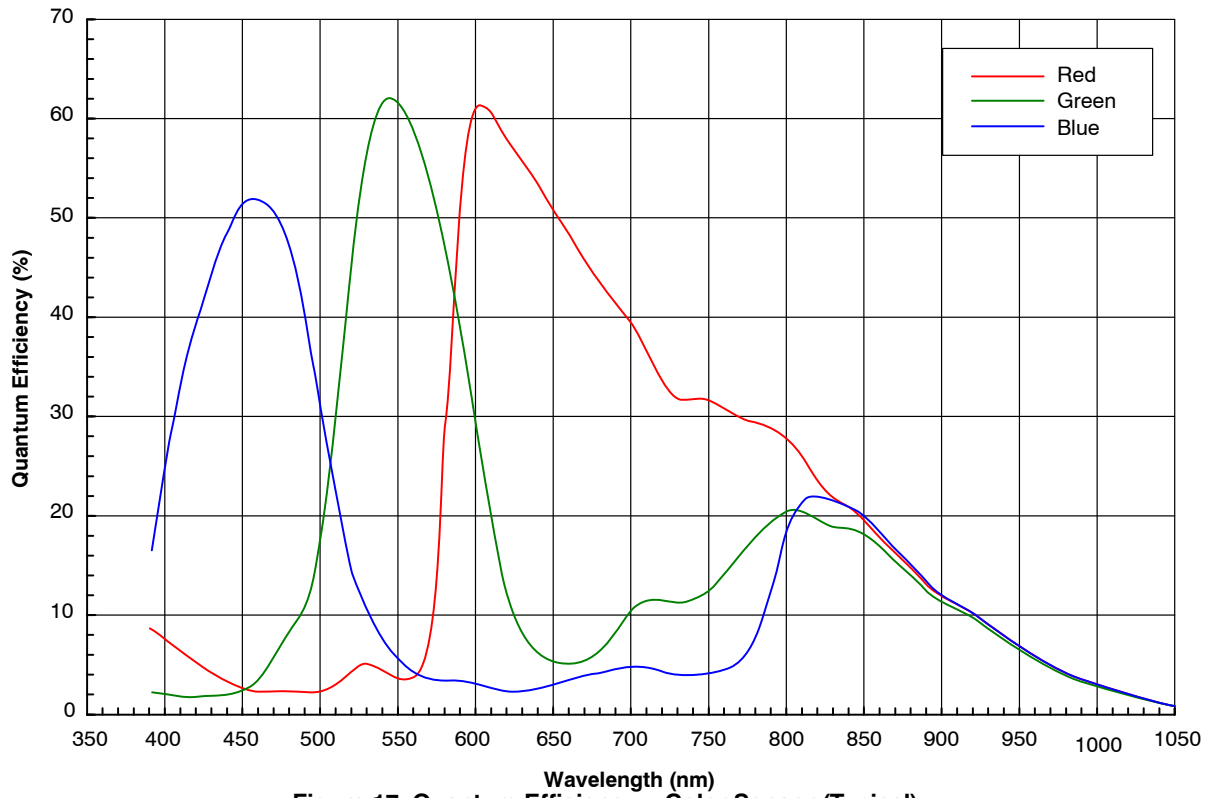

Figure 17. Quantum Efficiency - Color Sensor (Typical)

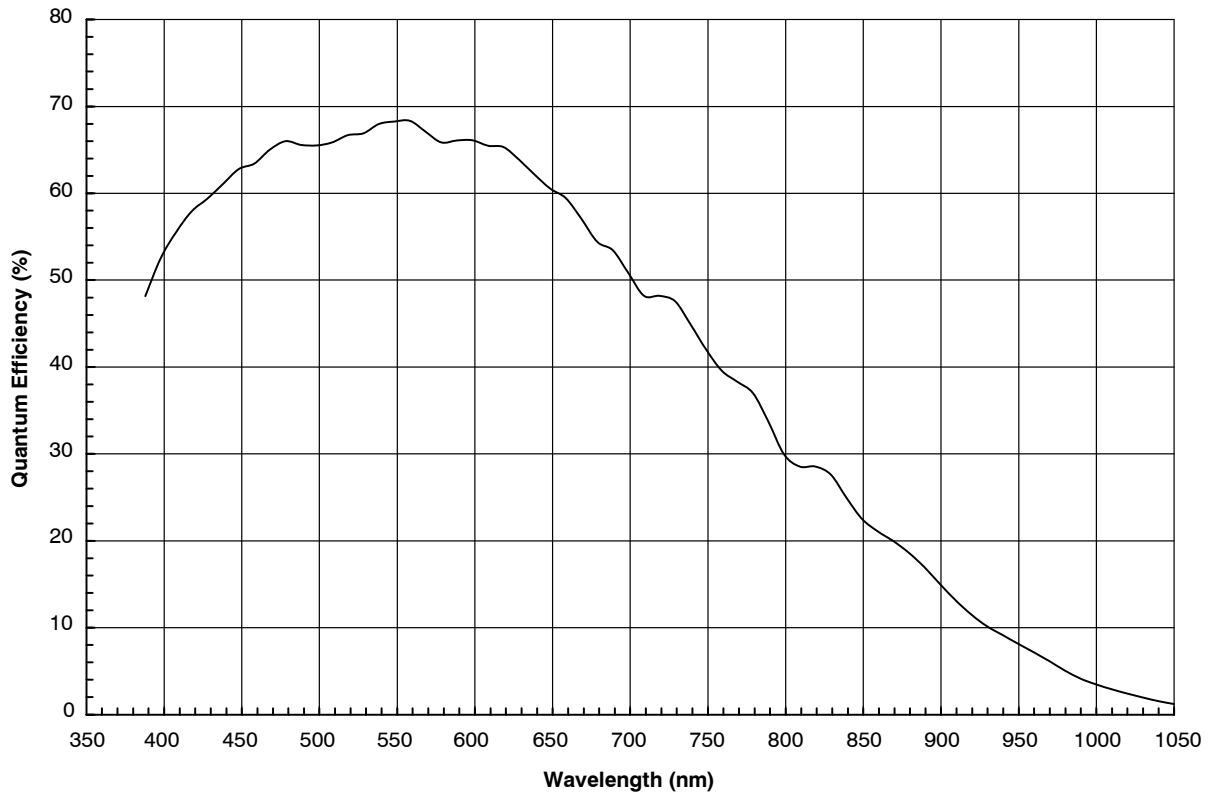

Figure 18. Quantum Efficiency - Monochrome Sensor (Typical)

CRA vs. Image Height Plot

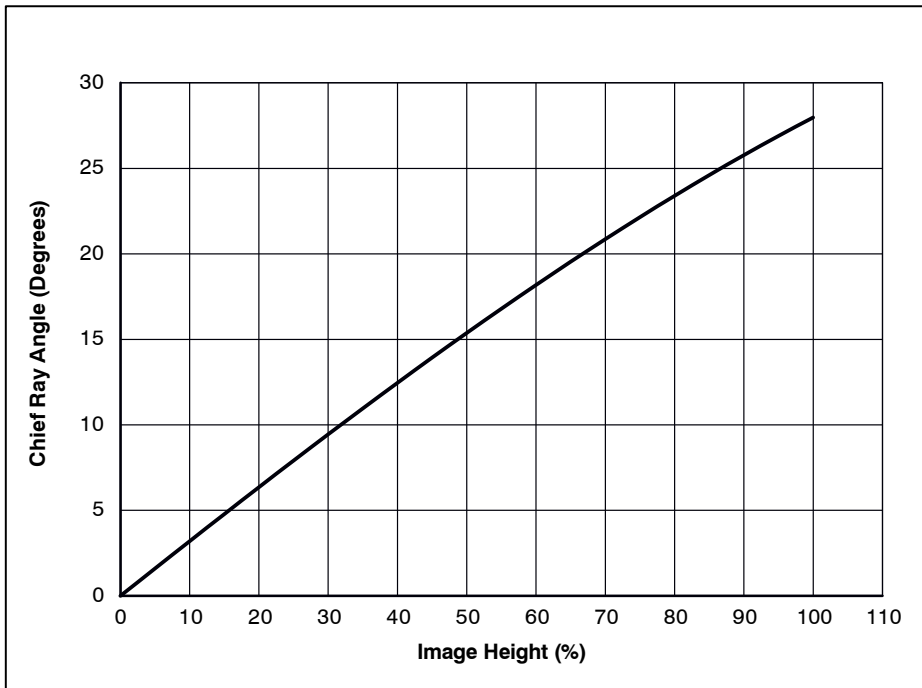

Figure 19. Chief Ray Angle – 28°

Image Height		CRA
(%)	(mm)	(deg)
0	0	0
5	0.170	1.61
10	0.340	3.20
15	0.509	4.79
20	0.679	6.36
25	0.849	7.91
30	1.019	9.45
35	1.189	10.97
40	1.358	12.46
45	1.528	13.93
50	1.698	15.38
55	1.868	16.79
60	2.038	18.18
65	2.208	19.54
70	2.377	20.86
75	2.547	22.15
80	2.717	23.39
85	2.887	24.60
90	3.057	25.77
95	3.226	26.90
100	3.396	27.97



**ODCSP83 5.595x9.995**  
**CASE 570CK**  
**ISSUE A**

DATE 16 AUG 2019

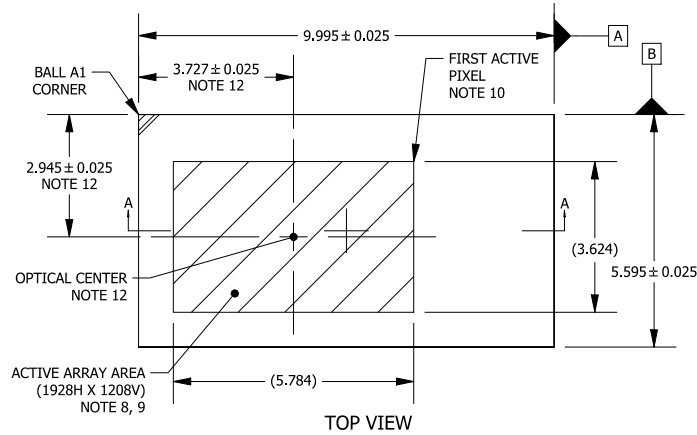

NOTES:

1. DIMENSIONING AND TOLERANCING PER ASME Y14.5M, 1994.
2. CONTROLLING DIMENSION: MILLIMETERS [mm].
3. SOLDER BALL DIAMETER IS MEASURED AT THE MAXIMUM SOLDER BALL DIAMETER PARALLEL TO DATUM C.
4. COPLANARITY APPLIES TO THE SPHERICAL CROWNS OF THE SOLDER BALLS.
5. DATUM C, THE SEATING PLANE IS DEFINED BY THE SPHERICAL CROWNS OF THE SOLDER BALLS.
6. GLASS: 0.400 THICKNESS; REFRACTIVE INDEX = 1.52.
7. AIR GAP BETWEEN GLASS AND PIXEL ARRAY: 0.044 THICKNESS.
8. PARALLELISM APPLIES ONLY TO THE ACTIVE ARRAY.
9. MAXIMUM ROTATION OF ACTIVE ARRAY RELATIVE TO DATUMS A AND B IS ± 0.1°.
10. REFER TO THE DEVICE DATA SHEET FOR TOTAL PIXEL ARRAY DEFINITIONS.
11. PACKAGE CENTER (X, Y) = (0.000, 0.000).
12. OPTICAL CENTER RELATIVE TO PACKAGE CENTER (X, Y) = (-1.271, -0.148).

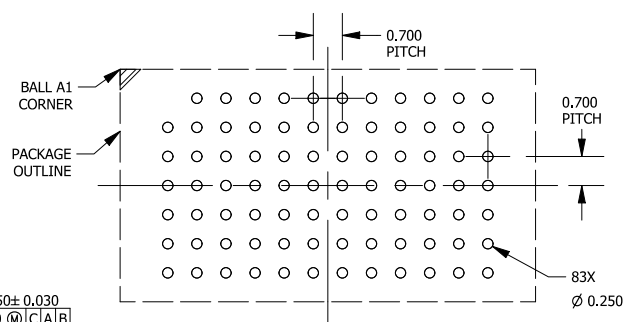
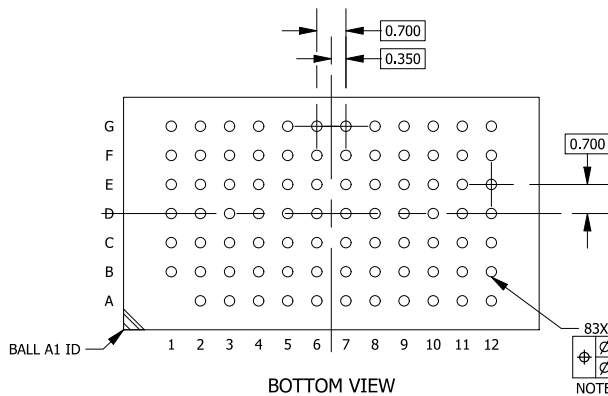
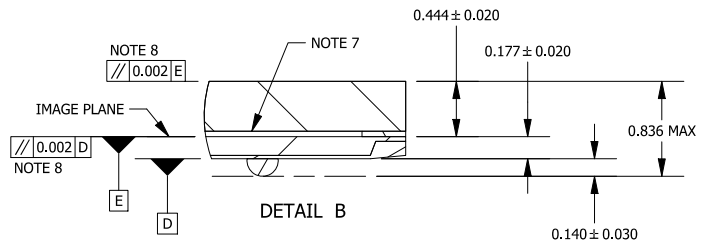
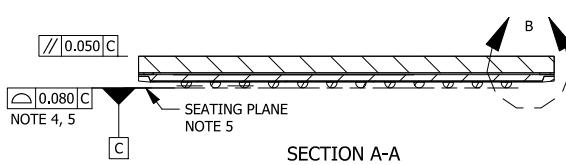

\*FOR ADDITIONAL INFORMATION ON OUR Pb-FREE STRATEGY AND SOLDERING DETAILS, PLEASE DOWNLOAD THE ON SEMICONDUCTOR SOLDERING AND MOUNTING TECHNIQUES REFERENCE MANUAL, SOLDERRM/D.

<b>DOCUMENT NUMBER:</b>	<b>98AON87372G</b>	Electronic versions are uncontrolled except when accessed directly from the Document Repository. Printed versions are uncontrolled except when stamped "CONTROLLED COPY" in red.
<b>DESCRIPTION:</b>	<b>ODCSP83 5.595x9.995</b>	<b>PAGE 1 OF 1</b>

ON Semiconductor and ON are trademarks of Semiconductor Components Industries, LLC dba ON Semiconductor or its subsidiaries in the United States and/or other countries. ON Semiconductor reserves the right to make changes without further notice to any products herein. ON Semiconductor makes no warranty, representation or guarantee regarding the suitability of its products for any particular purpose, nor does ON Semiconductor assume any liability arising out of the application or use of any product or circuit, and specifically disclaims any and all liability, including without limitation special, consequential or incidental damages. ON Semiconductor does not convey any license under its patent rights nor the rights of others.



ON Semiconductor and  are trademarks of Semiconductor Components Industries, LLC dba ON Semiconductor or its subsidiaries in the United States and/or other countries. ON Semiconductor owns the rights to a number of patents, trademarks, copyrights, trade secrets, and other intellectual property. A listing of ON Semiconductor's product/patent coverage may be accessed at [www.onsemi.com/site/pdf/Patent-Marking.pdf](http://www.onsemi.com/site/pdf/Patent-Marking.pdf). ON Semiconductor reserves the right to make changes without further notice to any products herein. ON Semiconductor makes no warranty, representation or guarantee regarding the suitability of its products for any particular purpose, nor does ON Semiconductor assume any liability arising out of the application or use of any product or circuit, and specifically disclaims any and all liability, including without limitation special, consequential or incidental damages. Buyer is responsible for its products and applications using ON Semiconductor products, including compliance with all laws, regulations and safety requirements or standards, regardless of any support or applications information provided by ON Semiconductor. "Typical" parameters which may be provided in ON Semiconductor data sheets and/or specifications can and do vary in different applications and actual performance may vary over time. All operating parameters, including "Typicals" must be validated for each customer application by customer's technical experts. ON Semiconductor does not convey any license under its patent rights nor the rights of others. ON Semiconductor products are not designed, intended, or authorized for use as a critical component in life support systems or any FDA Class 3 medical devices or medical devices with a same or similar classification in a foreign jurisdiction or any devices intended for implantation in the human body. Should Buyer purchase or use ON Semiconductor products for any such unintended or unauthorized application, Buyer shall indemnify and hold ON Semiconductor and its officers, employees, subsidiaries, affiliates, and distributors harmless against all claims, costs, damages, and expenses, and reasonable attorney fees arising out of, directly or indirectly, any claim of personal injury or death associated with such unintended or unauthorized use, even if such claim alleges that ON Semiconductor was negligent regarding the design or manufacture of the part. ON Semiconductor is an Equal Opportunity/Affirmative Action Employer. This literature is subject to all applicable copyright laws and is not for resale in any manner.

## PUBLICATION ORDERING INFORMATION

### LITERATURE FULFILLMENT:

Email Requests to: [orderlit@onsemi.com](mailto:orderlit@onsemi.com)

ON Semiconductor Website: [www.onsemi.com](http://www.onsemi.com)

### TECHNICAL SUPPORT

North American Technical Support:  
Voice Mail: 1 800-282-9855 Toll Free USA/Canada  
Phone: 011 421 33 790 2910

Europe, Middle East and Africa Technical Support:

Phone: 00421 33 790 2910

For additional information, please contact your local Sales Representative