

AR9287 Single-Chip 2x2 MIMO MAC/BB/Radio with PCIE Interface for 802.11n 2.4 GHz WLANs

General Description

The Atheros AR9287 is a highly integrated single-chip solution for 2.4 GHz 802.11n-ready WLANs to enable high-performance 2x2 MIMO configurations for applications demanding robust link quality and maximum throughput and range. The AR9287 integrates a multi-protocol MAC, baseband processor, analog-to-digital and digital-to-analog (ADC/DAC) converters, 2x2 MIMO radio transceiver including LNA, PA, and RF switch, and PCI Express interface in an all-CMOS device for low power and small form factor applications.

The AR9287 implements half-duplex OFDM, CCK, and DSSS baseband processing, supporting up to 150 Mbps for 20 MHz and 300 Mbps for 40 MHz channel operations respectively, and IEEE 802.11b/g data rates. Additional features include signal detection, automatic gain control, frequency offset estimation, symbol timing, and channel estimation. The AR9287 MAC supports the 802.11 wireless MAC protocol, 802.11i security, receive and transmit filtering, error recovery, and quality of service (QoS).

The AR9287 supports two simultaneous traffic streams using up to two integrated transmit chains and receive chains for high throughput and range performance. Transmit chains combine baseband in-phase (I) and quadrature (Q) signals, convert them to the desired frequency, and drive the RF signal to multiple antennas. Receive chains convert RF signal to baseband I and Q outputs. The frequency synthesizer supports one-MHz steps to match frequencies defined by IEEE 802.11b/g/n specifications.

The AR9287 supports frame data transfer to and from the host using a PCIE interface providing interrupt generation and reporting, power save, and status reporting. Other external interfaces include serial EEPROM and GPIOs. The AR9287 operates with standard legacy 802.11b/g devices.

Features

- All-CMOS MIMO solution interoperable with IEEE 802.11b/g/n WLANs
- 2x2 MIMO technology improves effective throughput and range over existing 802.11b/g products
- Integrated LNAs, PAs, and RF switches eliminate the need for external front-end modules
- Supports spatial multiplexing, cyclic-delay diversity (CDD), and maximal ratio combining (MRC)
- 2.4 GHz WLAN MAC/BB processing
- BPSK, QPSK, 16 QAM, 64 QAM, DBPSK, DQPSK, and CCK modulation schemes
- Data rates of up to 150 Mbps for 20 MHz channels and 300 Mbps for 40 MHz channels
- Wireless multimedia enhancements for QoS
- 802.11e-compatible bursting
- Support for IEEE 802.11e, h, and i standards
- WEP, TKIP, and AES hardware encryption
- 20 and 40 MHz channelization
- PCIE 1.1 compliant
- Support for 2–3 wire Bluetooth coexistence
- Reduced (short) guard interval
- Frame aggregation
- Block ACK
- IEEE 1149.1 standard test access port and boundary scan architecture supported
- 9 mm x 9 mm 76-pin LPCC package

AR9287 System Block Diagram

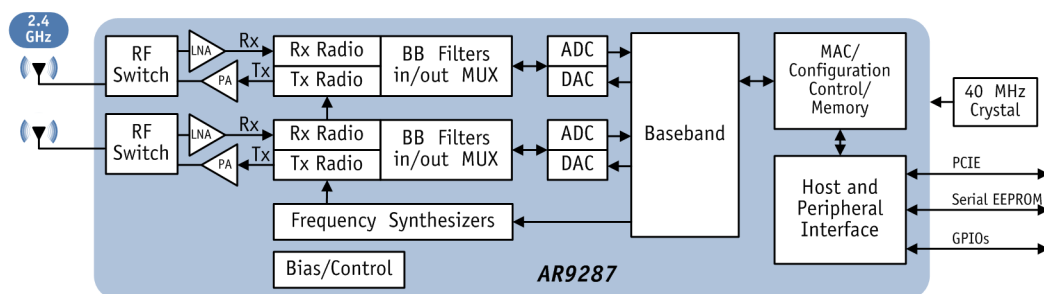

Table of Contents

General Description	1
Features	1
AR9287 System Block Diagram	1

1 Pin Descriptions 1

2 Functional Description 7

2.1 Overview	7
2.1.1 Configuration Block	7
2.1.2 AR9287 Address MAP	7
2.1.3 Serial EEPROM Interface	8
2.1.4 EEPROM Auto-Sizing Mechanism	8
2.1.5 EEPROM Read/Write Protection Mechanism	8
2.2 Reset	8
2.3 GPIO	8
2.4 LED	8
2.5 PCI Express Host Interface	9
2.5.1 PCI Express Registers	9
2.6 Signal Description	9
2.7 Host Interface Unit Interrupts	9

3 Medium Access Control (MAC) 11

3.1 Overview	11
3.2 Descriptor	11
3.3 Descriptor Format	12
3.4 Queue Control Unit (QCU)	28
3.4.1 DCF Control Unit (DCU)	28
3.5 Protocol Control Unit (PCU)	28

4 Digital PHY Block 29

4.1 Overview	29
4.2 802.11n (MIMO) Mode	29
4.2.1 Transmitter (Tx)	29
4.2.2 Receiver (Rx)	29
4.3 802.11b/g Legacy Mode	30
4.3.1 Transmitter	30
4.3.2 Receiver	30

5 Radio Block 31

5.1 Receiver (Rx) Block	31
-------------------------------	----

5.2 Transmitter (Tx) Block	32
5.3 Synthesizer (SYNTH) Block	33
5.4 Bias/Control (BIAS) Block	33

6 LDO Circuit Recommendation .35

6.1 PNP Transistor	35
--------------------------	----

7 Register Descriptions37

7.1 PCI Express Configuration Space Registers 37	
7.1.1 Vendor ID (VENDOR_ID)	38
7.1.2 Device ID (DEVICE_ID)	38
7.1.3 Command (COMMAND)	39
7.1.4 Status (STATUS)	40
7.1.5 Revision ID (REVISION_ID)	40
7.1.6 Class Code (CLASS_CODE)	41
7.1.7 Cache Line Size (CACHE_SZ)	41
7.1.8 Latency Timer (LATENCY_TMR)	41
7.1.9 Header Type (HDR_TYPE)	41
7.1.10Base Address (BASE_ADDR)	41
7.1.11 Subsystem Vendor ID (SSYS_VEND_ID)	42
7.1.12 Subsystem ID (SSYS_ID)	42
7.1.13 Capabilities Pointer (CAP_PTR)	42
7.1.14 Interrupt Line (INT_LINE)	42
7.1.15 Interrupt Pin (INT_PIN)	42
7.1.16 Power Management Capability	43
7.1.17 Power Management Status/Control	44
7.1.18 Message Capability ID (CAP_ID)	44
7.1.19 Message Capability Next Pointer (NXT_PTR)	44
7.1.20 Message Control	45
7.1.21 Message Address	46
7.1.22 Message Data	46
7.1.23 PCI Express Capabilities List	46
7.1.24 PCI Express Capabilities	47
7.1.25 Link Capabilities	47
7.1.26 Link Control	48
7.2 AR9287 Internal Register Descriptions 48	
7.2.1 General DMA and Rx-Related Registers	49
7.2.2 Beacon Handling	68
7.2.3 QCU Registers	70

7.2.4	DCU Registers	76
7.2.5	MAC Interface	86
7.2.6	EEPROM Interface Registers	87
7.2.7	Host Interface Registers	87
7.2.8	RTC Interface Registers	99
7.2.9	MAC PCU Registers	103
7.2.10	Wake-on-Wireless Register	129
8	Electrical Characteristics	133
8.1	Absolute Maximum Ratings	133
8.2	Recommended Operating Conditions	133
8.3	40 MHz Clock Characteristics	134
8.4	GPIO DC Electrical Characteristics	134
8.5	PCIE Pin Characteristics	135
8.6	Power Up Sequencing	136
8.7	EEPROM Timing Specifications	137
8.8	Radio Characteristics	138
8.8.1	Receiver Characteristics	138
8.8.2	Transmitter Characteristics	139
8.8.3	Synthesizer Characteristics	140
8.9	Power Consumption Parameters	140
9	Package Dimensions	141
10	Ordering Information	143

1. Pin Descriptions

This section contains a package pinout (see [Figure 1-1](#) and [Table 1-1](#)) and a tabular listing of the signal descriptions.

This nomenclature is used for signal names:

NC	No connection should be made to this pin
_L	At the end of the signal name, indicates active low signals
P	At the end of the signal name, indicates the positive side of a differential signal
N	At the end of the signal name indicates the negative side of a differential signal

This nomenclature is used for signal types:

I	Digital input signal
I/O	A digital bidirectional signal
IA	Analog input signal
IH	Input signals with weak internal pull-up, to prevent signals from floating when left open
IL	Input signals with weak internal pull-down, to prevent signals from floating when left open
O	A digital output signal
OA	An analog output signal
OD	A digital output signal with open drain
P	A power or ground signal

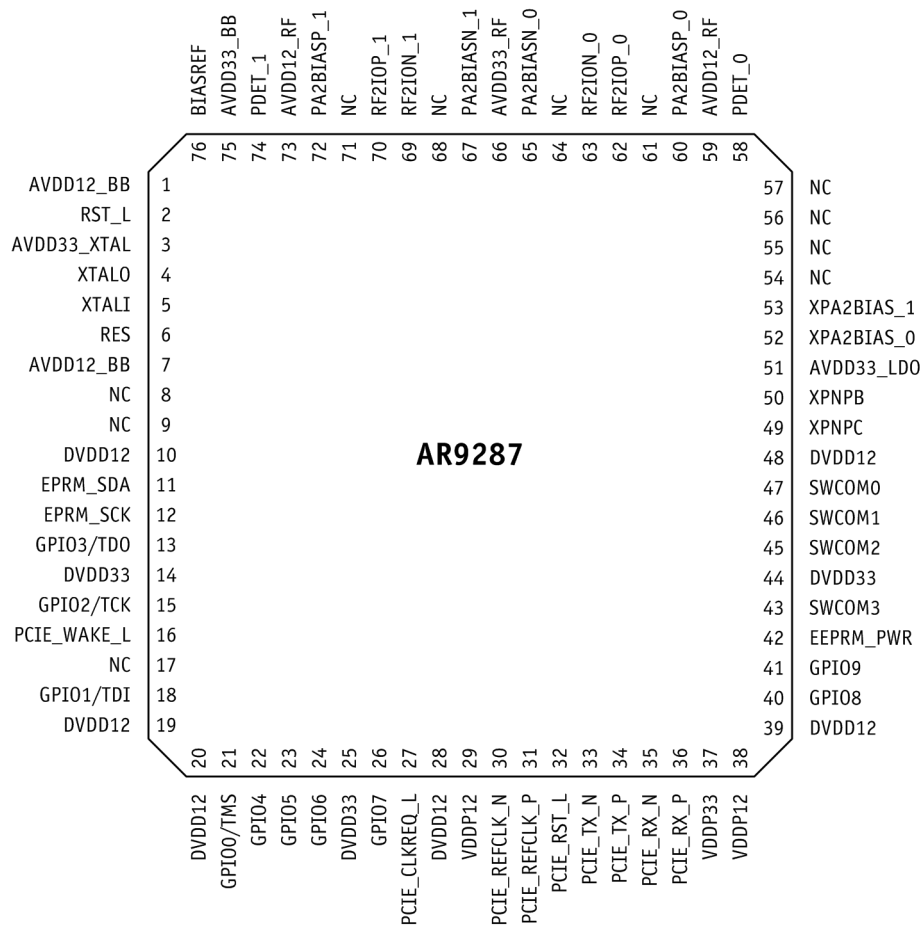

Figure 1-1. LPCC Package Pin Assignments

Table 1-1. Signal-to-Pin Relationships and Descriptions

Symbol	Pin	Type	Description
PCIE			
PCIE_CLKREQ_L	27	OD	Clock request, for starting and stopping the PCIE clock
PCIE_REFCLK_N	30	IA	Differential reference clock (100 MHz)
PCIE_REFCLK_P	31	IA	
PCIE_RST_L	32	I	PCIE reset
PCIE_RX_N	35	IA	Differential receive
PCIE_RX_P	36	IA	
PCIE_TX_N	33	OA	Differential transmit
PCIE_TX_P	34	OA	
PCIE_WAKE_L	16	OD	PCIE power management
Radio			
BIASREF	76	OA	BIASREF voltage is 310 mV; must connect a 6.19 K Ω \pm 1% resistor to ground
RF2ION_0	63	IA/OA	Differential RF inputs/outputs at 2.4 GHz for chain 0. Use one side for single-ended input.
RF2IOP_0	62	IA/OA	
RF2ION_1	69	IA/OA	Differential RF inputs/outputs at 2.4 GHz for chain 1. Use one side for single-ended input.
RF2IOP_1	70	IA/OA	
Analog Interface			
PA2BIASN_0	65	IA	External bias for 2.4 GHz for chain 0
PA2BIASP_0	60	IA	
PA2BIASN_1	67	IA	External bias for 2.4 GHz for chain 1
PA2BIASP_1	72	IA	
PDET_0	58	IA	Connect to external power detectors outputs
PDET_1	74	IA	
XPA2BIAS_0	52	OA	Bias for external power amplifier for chain 0
XPA2BIAS_1	53	OA	Bias for external power amplifier for chain 1
External Switch Control			
SWCOM0	47	O	Common switch control
SWCOM1	46	O	
SWCOM2	45	O	
SWCOM3	43	O	
General			
RST_L	2	IH	Reset for the AR9287
XTALI	5	I	Crystal oscillator input and output See “40 MHz Clock Characteristics” on page 134
XTALO	4	O	

Table 1-1. Signal-to-Pin Relationships and Descriptions (continued)

Symbol	Pin	Type	Description
GPIO			
GPIO0/TMS	21	I/O	General purpose GPIO pins The GPIO pins GPIO0 through GPIO3 are multiplexed pins that default to the JTAG interface.
GPIO1/TDI	18	I/O	
GPIO2/TCK	15	I/O	
GPIO3/TDO	13	I/O	
GPIO4	22	I/O	
GPIO5	23	I/O	
GPIO6	24	I/O	
GPIO7	26	I/O	
GPIO8	40	I/O	
GPIO9	41	I/O	
Serial EEPROM			
EEPRM_PWR	42	I/O	Power up an external EEPROM device
EPRM_SCK	12	O	Serial EEPROM clock
EPRM_SDA	11	I/O	Serial EEPROM data

Symbol	Pin	Description
Power		
XPNPB	50	Connect to the base of the external PNP; see “LDO Circuit Recommendation” on page 35
XPNPC	49	Connect to the collector of the external PNP; see “LDO Circuit Recommendation” on page 35
AVDD12_BB	1, 7	Analog 1.25 V power supply
AVDD12_RF	59, 73	
AVDD33_BB	75	Analog 3.3 V power supply
AVDD33_LDO	51	
AVDD33_RF	66	
AVDD33_XTAL	3	Supply voltage for the crystal oscillator
DVDD12	10, 19, 20, 28, 39, 48	Digital 1.25 V power supply
DVDD33	14, 25, 44	Digital 3.3 V power supply
VDDP12	29, 38	PCIE 1.25 V power supply
VDDP33	37	PCIE 3.3 V power supply
RES	6	Reserved; Can be left open, or connected to ground, refer to the reference design schematic
NC	8, 9, 17, 54, 55, 56, 57, 61, 64, 68, 71	No connect
Ground Pad		
Exposed Ground Pad	—	Tied to GND (see “Package Dimensions” on page 141)

2. Functional Description

2.1 Overview

The AR9287 consists of four major functional blocks: PCI Express interface, MAC, digital PHY, and radio.

The IEEE 802.11 MAC functionality is partitioned between the host and the AR9287. IEEE 802.11 MAC data service is provided by the MAC of the AR9287, while the host software, with the aid of the AR9287 MAC, controls Tx and Rx queue processing.

The baseband digital processing functions are implemented by the digital PHY of the AR9287. The radio frequency (RF) and baseband analog processing are provided by the integrated radio. The physical layer (PHY) is partitioned between the baseband processor and the radio. The configuration block, PLL, ADC, DAC, EEPROM interface, JTAG, antenna control, and GPIO complete the AR9287 functionality. See [Figure 2-1](#).

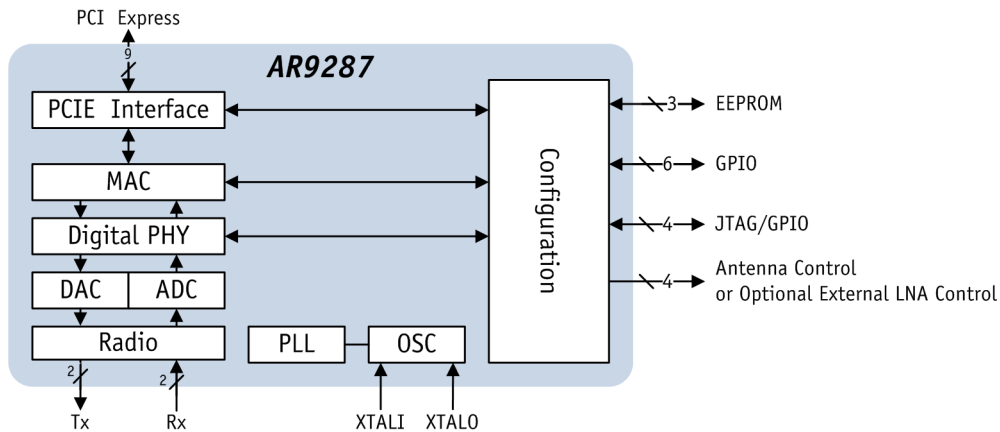

Figure 2-1. Functional Block Diagram of the AR9287

2.1.1 Configuration Block

The configuration block provides control, status, and configuration, for each major functional block. This block contains registers accessed by other blocks and by the host using the PCI Express interface.

2.1.2 AR9287 Address MAP

Internal registers of the various functional blocks and the AR9287 peripheral interface are accessible with the host using the PCI Express interface. These register locations are defined as offset addresses. The combination of the host base address and the offset address allows access to a particular internal register. [Table 2-1](#) lists the offset addresses for the AR9287 internal registers and peripheral interface.

Table 2-1. Offset Addresses

Offset Location	Usage	Description
0x0000–0x07FC	MAC DMA general	DMA access
0x0800–0x0FFC	MAC DMA QCU registers	Control and status register for QCU
0x1000–0x1FFC	DCU registers	Control and status register for DCU
0x2000–0x3FFC	EEPROM access register	Memory location of EEPROM are mapped to this address range and allow access to EEPROM
0x4000–0x4FFC	Host interface	Control and status register for host interface
0x8000–0x98FC	PCU registers	Control and status register for PCU

2.1.3 Serial EEPROM Interface

The AR9287 provides a serial interface to access an external EEPROM. The EEPROM interface modifies configuration space registers and configuration- and vendor-specific information.

The off-chip EEPROM can be:

- A 16-Kb device, organized as 1,024 entries of 16 bits each (1,024x16)
- An 8-Kb device, organized as 512 entries of 16 bits each (512x16)

The hardware automatically detects EEPROM size. The EEPROM addressing is 16 bits wide, with each 16-bit EEPROM mapped into the AR9287's register space. Each 32-bit aligned address corresponds to a unique EEPROM location. Because the host interface supports 32-bit register accesses and ignores the two least significant address bits, the address offset provided by the host interface corresponds to four times the EEPROM location.

At reset, some PCI Express configuration registers load from the EEPROM while others are programmed by the host or initialized by AR9287 hardware. To ensure that the EEPROM contents are valid, a 16-bit word at address offset 0x2000 is checked. If the values do not match 0xA55A, the EEPROM contents are ignored and the default values loaded.

2.1.4 EEPROM Auto-Sizing Mechanism

The first procedure after reset is to read the offset address 0x2000 to check for the content 0xA55A. The EEPROM physical presence, programmed state, and size are determined automatically. If the offset address 0x2000 contents do not match the 0xA55A value for any supported EEPROM sizes, the AR9287 assumes the EEPROM is not present on the PCB, or is present but not programmed. In either case, the logic uses the default values as described in “Serial EEPROM Interface”.

2.1.5 EEPROM Read/Write Protection Mechanism

The EEPROM contains a 16-bit word protect mask value at address location 0x2010H that prevents software from accessing certain regions. The mask is 16 bits wide and contains eight sub-masks that are 2 bits wide.

The sub-mask can have four values that determine the access types permitted to the associated protection region:

- 00: Read/write access allowed
- 01: Write-only access allowed
- 10: Read-only access allowed
- 11: No access allowed

2.2 Reset

The RST_L pin controls the AR9287 chip reset. The AR9287 host interface receives two reset signals as below:

- RST_L pin
Controls the AR9287 power reset
- PCIE_RESET_L
Controls the PCI Express core reset

In addition, the RTC_RESET register provides software control of warm reset for the MAC/baseband and PCU blocks. See the register “RTC Reset and Force Sleep and Force Wakeup (RTC_RESET)”.

2.3 GPIO

The AR9287 provides ten configurable bi-directional general purpose I/O ports. Each GPIO can be independently configured as input or output using the GPIO control register. Information presented at the GPIO inputs and outputs can be read from the register H_GPIO_IN_OUT (see “GPIO Input and Output (H_GPIO_IN_OUT)”).

2.4 LED

The AR9287 provides GPIO pins to configure for LED output. Control for LED output is provided by the “MAC LED Control Register (MAC_LED)” on page 86.

2.5 PCI Express Host Interface

This section provides a summary of the AR9287 PCI Express interface. This interface is PCI Express 1.1 compliant. It functions as the host interface for the AR9287, providing data and command transfer between the host software, the MAC, and the configuration registers. For details, refer to the PCI Express 1.1 standards specifications.

2.5.1 PCI Express Registers

At system boot, the host uses the PCI Express configuration registers to detect the type of device present and to perform low level PCI Express configuration (e.g., assigning a base address to the device).

An external serial EEPROM provides device configuration information. At reset, some PCI Express configuration registers load from the off-chip serial EEPROM, whereas the host must program the others. Configuration, control, and status registers for the various functional blocks of the AR9287 map to the memory space of the PCI Express interface and thus can be accessed by the host.

2.6 Signal Description

The AR9287 PCI Express interface pins are described in “Pin Descriptions” on page 1. Table 2-2 shows the interface pins grouped by functional type.

Table 2-2. Types of PCI Express Interface Signals

Type	Pins
Differential reference clock (100 MHz)	PCIE_REFCLK_N
	PCIE_REFCLK_P
Differential receive	PCIE_RX_N
	PCIE_RX_P
Differential transmit	PCIE_TX_N
	PCIE_TX_P
Reference clock request	PCIE_CLKREQ_L
Request to service a function-initiated wake event	PCIE_WAKE_L
PCI Express fundamental reset	PCIE_RESET_L

2.7 Host Interface Unit Interrupts

The AR9287 host interface unit supports:

- Asynchronous mode interrupt
- Synchronous mode interrupt

Software can control and program both the “Synchronous Interrupt Cause (H_INTR_SYNC_CAUS)” and “Asynchronous Interrupt Cause (H_INTR_ASYNC_CAUS)” registers. Because both registers contain similar bits, software should keep the synchronous and asynchronous interrupt enable registers mutually exclusive.

3. Medium Access Control (MAC)

The MAC consists of the following major functional blocks: 10 queue control units (QCU), 10 distributed coordination function

(DCF) control units (DCU), a single DMA Rx unit (DRU), and a single protocol control unit (PCU). See [Figure 3-1](#).

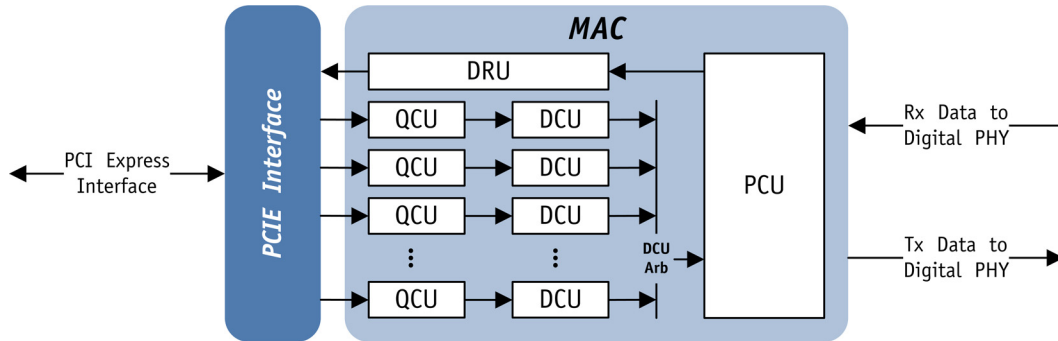

Figure 3-1. MAC Block Diagram

3.1 Overview

The MAC block supports full bus-mastering descriptor-based scatter/gather DMA. Frame transmission begins with the QCU. QCU manage the DMA of frame data from the host through the PCI Express interface, and determine when a frame is available for transmission.

Each QCU targets exactly one DCU. Ready frames are passed from a QCU to its targeted DCU. The DCU manages the enhanced distributed coordination function (EDCF) channel access procedure on behalf of the QCU associated with it.

Functionality of the MAC block includes:

- Tx frame data transfer from the host to the radio block using the PCI Express bus
- Rx frame data transfer from the radio block to host using the PCI Express bus
- Register access to all AR9287 registers
- Interrupt generation and reporting
- Sleep-mode (power-down) sequencing
- Miscellaneous error and status reporting functions

Once the DCU gains access to the channel, it passes the frame to the PCU, which encrypts the frame and sends it to the baseband logic. The PCU handles both processing responses to the transmitted frame, and reporting the transmission attempt results to the DCU.

Frame reception begins in the PCU, which receives the incoming frame bitstream from the digital PHY. The PCU decrypts the frame and passes it to the DRU, which manages Rx descriptors and writes the incoming frame data and status to the host memory through the PCI Express interface.

3.2 Descriptor

The MAC is responsible for transferring frames between the host memory (accessed using the PCI Express interface) and the AR9287. For all normal frame transmit/receive activity, the host provides a series of descriptors to the MAC, and the MAC then parses the descriptors and performs the required set of data transfers.

3.3 Descriptor Format

The transmit (Tx) descriptor format contains 24 32-bit words and the receive (Rx) descriptor 13 32-bit words (see [Table 3-1](#)).

The first two words of the descriptor point to the next descriptor in the linked list and to the data buffer associated with the descriptor. Other words carry additional control information that affects how the MAC processes the frame and its data.

A descriptor is required to be aligned on a 32-bit boundary in host memory, although best performance is achieved if the descriptor is aligned on a cache-line boundary. The MAC uses the final two words to report status information back to the host. See:

Table	Description
Table 3-2	Tx control descriptor format (words 2–13)
Table 3-3	Tx status descriptors (words 14–23)
Table 3-4	Rx control descriptor (words 2–3)
Table 3-5	Rx status descriptor (words 4–12)

Table 3-1. DMA Descriptor Format

Word	Bits	Field Name	Description
0	31:0	link_ptr	Link pointer. Contains the address of the next descriptor to be used; must be 32-bit aligned (bits [1:0] must be 0)
1	31:0	buf_ptr	Data buffer pointer. Contains the starting address of the data buffer associated with this descriptor. A Tx data buffer can begin at any byte address. A Rx data buffer must be aligned on a 32-bit boundary in host memory, although best performance is achieved if the Rx data buffer is cache-line aligned. (Cache-line size varies from system to system.)
2–13 (Tx) 2–3 (Rx)	31:0	Host-to-DMA engine control information	Additional control information is passed from host to DMA engine. The format of these words varies depending on whether the descriptor is being used to Tx a frame from host to PCU, or Rx a frame from PCU to host. (See Table 3-2 on page 13, and Table 3-4 on page 24 for details.)
14–23 (Tx) 4–12 (Rx)	31:0	DMA completion status information	Status information reported by the DMA engine when it has finished processing a descriptor. As with the control information, the format of the status information differs between Tx and Rx descriptors. (See Table 3-3 on page 20, and Table 3-5 on page 24 for details.)

The Tx descriptor format for words 2 through 13 is described in [Table 3-2](#).

Table 3-2. Tx Control Descriptor Format (Words 2–13)

Word	Bits	Field Name	Description				
2	11:0	frame_length	Frame length Specifies the length, in bytes, of the entire MAC frame, including the frame check sequence (FCS), initialization vector (IV), and integrity check value (ICV) fields.				
	12	vmf	Virtual more fragment If this bit is set, bursting is enabled for this frame. If no burst is in progress, it initiates a CTS-protected burst if <code>cts_enable</code> is set. If a previous burst is in progress, it ignores the <code>cts_enable</code> bit and assumes the burst is protected.				
	13	RES	Reserved				
	14	low_rx_chain	When set to 1, indicates that the Rx chain mask switches to low power mode after transmitting this frame.				
	15	clear_retry	Setting this bit disables the retry bit from being set in the Tx header on a frame retry (applies to both aggregate and non-aggregate frames).				
	21:16	tpc_0	Tx power control for series 0 These bits pass unchanged to the baseband, where they are used to control the transmit power for the frame.				
	22	rts_enable	Request to send (RTS) enable. At most, one of the “ <code>rts_enable</code> ” and “ <code>cts_enable</code> ” bits may be set; it is illegal to set both. <table border="1" style="width: 100%; border-collapse: collapse;"> <tr> <td style="width: 10%; text-align: center;">set</td> <td>PCU transmits the frame using the RTS/CTS protocol</td> </tr> <tr> <td style="text-align: center;">clear</td> <td>PCU transmits the frame using the contention/backoff protocol</td> </tr> </table>	set	PCU transmits the frame using the RTS/CTS protocol	clear	PCU transmits the frame using the contention/backoff protocol
set	PCU transmits the frame using the RTS/CTS protocol						
clear	PCU transmits the frame using the contention/backoff protocol						
	23	veol	Virtual end-of-list flag When set, indicates that the QCU should act as though the descriptor had a NULL LinkPtr, even if the LinkPtr is not NULL. Must be valid in the final descriptor of a frame and must be clear for all other descriptors of the frame.				
	24	clear_dest_mask	Clear destination mask bit flag If set, instructs the PCU and DCU to clear the destination mask bit at the index specified by the DestIdx field.				
	28:25	RES	Reserved				
	29	int_req	Interrupt request flag Set to one by the driver to request that the DMA engine generate an interrupt upon completion of the frame to which this descriptor belongs. Note that this field must be valid and identical for all descriptors of the frame; that is, all descriptors for the frame must have this flag set, or all descriptors for the frame must have this flag clear.				
	30	dest_index_valid	Destination index valid flag Specifies whether the contents of the DestIdx field are valid.				
	31	cts_enable	Proceed frame with CTS flag If set, the PCU first sends a CTS before sending the frame described by the descriptor. Used for 802.11g and Atheros XR frames to quiet legacy stations before sending a frame the legacy stations cannot interpret (even at the PHY level). At most, one of the “ <code>rts_enable</code> ” and “ <code>cts_enable</code> ” bits may be set; it is illegal to set both bits.				

Table 3-2. Tx Control Descriptor Format (Words 2–13) (continued)

Word	Bits	Field Name	Description	
3	11:0	buf_len	Data buffer length Specifies the length, in bytes, of the data buffer associated with this descriptor. Tx data buffers may be any non-zero length buffers. This field must be valid for all descriptors.	
	12	more	More descriptors in this frame flag Set to one by the driver to indicate additional descriptors (DMA fragments) exist in the current frame. This field must be valid for all descriptors.	
			0	No more descriptors for the current frame
	1	The current frame is continued in the next descriptor		
19:13		dest_index	Destination table index Specifies an index to an on-chip table of per-destination information. The PCU fetches the encryption key from the specified index in this table and uses the key to encrypt the frame. DMA logic uses the index to maintain per-destination Tx filtering status and other related information.	
23:20		frame_type	Frame type indication Indicates to the PCU what type of frame is being sent. Supported values:	
			0	Normal frame
			1	Announcement traffic indication message (ATIM) frame
			2	PS poll frame
			3	Beacon
			4	Probe response frame
	15:5	Reserved		
24		no_ack	No ACK flag Must be set for any frame that has the 802.11 NoAck bit set in the QoS field and for all other frame types (e.g., beacons) that do not receive ACKs.	
			1	Do not wait for ACK
28:25		RES	Reserved	
29		more_agg	Indicates aggregate boundaries	
30		is_agg	Set for all descriptors for an aggregate	
31		more_rifs	More RIFS burst flag When set, indicates that the current packet is not the last packet of an aggregate. All descriptors for all packets of a RIFS burst except the descriptors of the last packet must have this bit set. All descriptors of the last packet of a RIFS burst must have this bit clear.	

Table 3-2. Tx Control Descriptor Format (Words 2–13) (continued)

Word	Bits	Field Name	Description
4	14:0	burst_duration	Burst duration value (in μ s) If this frame is not part of a burst or the last frame in a burst, the value should be zero. In a burst, the value is the amount of time to reserve (via NAV) after completing the current Tx packet sequence (after the ACK if applicable).
	15	dur_update_en	Frame duration update control If set, the MAC updates (overwrites) the duration field in the frame based on the current Tx rate. If clear, the MAC does not alter the contents of the frame's Duration field. Note that the MAC changes only the frame's Duration field. It does not alter the Duration field in the RTS/CTS that precedes the frame itself if "rts_enable" or "cts_enable" is set.
	19:16	tx_tries0	Number of frame data exchange attempts permitted for Tx series 0 A "frame data exchange attempt" means a transmission attempt in which the actual frame is sent on the air (in contrast to the case in which the frame has RTS enabled and the RTS fails to receive a CTS). In this case, the actual frame is not sent on the air, so this does not count as a frame data exchange attempt. A value of zero is illegal for the TXDataTries0 field.
	23:20	tx_tries1	Number of frame data exchange attempts permitted for transmission series 1. A value of zero means skip this transmission series.
	27:24	tx_tries2	Number of frame data exchange attempts permitted for transmission series 2. A value of zero means skip this transmission series.
	31:28	tx_tries3	Number of frame data exchange attempts permitted for transmission series 3. A value of zero means skip this transmission series.

Table 3-2. Tx Control Descriptor Format (Words 2–13) (continued)

Word	Bits	Field Name	Description																																																																																					
5	7:0	tx_rate0	Tx rate for transmission series 0.																																																																																					
			<table border="1"> <thead> <tr> <th>Value</th> <th>Desc</th> <th>Value</th> <th>Desc</th> </tr> </thead> <tbody> <tr> <td>0x1–0x7</td> <td>RES</td> <td>0xF</td> <td>OFDM_9Mb</td> </tr> <tr> <td>0x8</td> <td>OFDM_48Mb</td> <td>0x18</td> <td>CCK_11Mb_L</td> </tr> <tr> <td>0x9</td> <td>OFDM_24Mb</td> <td>0x19</td> <td>CCK_5_5Mb_L</td> </tr> <tr> <td>0xA</td> <td>OFDM_12Mb</td> <td>0x1A</td> <td>CCK_2Mb_L</td> </tr> <tr> <td>0xB</td> <td>OFDM_6Mb</td> <td>0x1B</td> <td>CCK_1Mb_L</td> </tr> <tr> <td>0xC</td> <td>OFDM_54Mb</td> <td>0x1C</td> <td>CCK_11Mb_S</td> </tr> <tr> <td>0xD</td> <td>OFDM_36Mb</td> <td>0x1D</td> <td>CCK_5_5Mb_S</td> </tr> <tr> <td>0xE</td> <td>OFDM_18Mb</td> <td>0x1E</td> <td>CCK_2Mb_S</td> </tr> </tbody> </table>	Value	Desc	Value	Desc	0x1–0x7	RES	0xF	OFDM_9Mb	0x8	OFDM_48Mb	0x18	CCK_11Mb_L	0x9	OFDM_24Mb	0x19	CCK_5_5Mb_L	0xA	OFDM_12Mb	0x1A	CCK_2Mb_L	0xB	OFDM_6Mb	0x1B	CCK_1Mb_L	0xC	OFDM_54Mb	0x1C	CCK_11Mb_S	0xD	OFDM_36Mb	0x1D	CCK_5_5Mb_S	0xE	OFDM_18Mb	0x1E	CCK_2Mb_S																																																	
			Value	Desc	Value	Desc																																																																																		
			0x1–0x7	RES	0xF	OFDM_9Mb																																																																																		
			0x8	OFDM_48Mb	0x18	CCK_11Mb_L																																																																																		
			0x9	OFDM_24Mb	0x19	CCK_5_5Mb_L																																																																																		
			0xA	OFDM_12Mb	0x1A	CCK_2Mb_L																																																																																		
			0xB	OFDM_6Mb	0x1B	CCK_1Mb_L																																																																																		
			0xC	OFDM_54Mb	0x1C	CCK_11Mb_S																																																																																		
			0xD	OFDM_36Mb	0x1D	CCK_5_5Mb_S																																																																																		
			0xE	OFDM_18Mb	0x1E	CCK_2Mb_S																																																																																		
			<table border="1"> <thead> <tr> <th>Value^[1]</th> <th>Desc</th> <th>Stream</th> <th>HT20/HT40 GI = 0 (Mbps)</th> <th>HT20/HT40 GI = 1 (Mbps)</th> </tr> </thead> <tbody> <tr> <td>0x80</td> <td>MCS 0</td> <td>1</td> <td>13.5</td> <td>15</td> </tr> <tr> <td>0x81</td> <td>MCS 1</td> <td>1</td> <td>27</td> <td>30</td> </tr> <tr> <td>0x82</td> <td>MCS 2</td> <td>1</td> <td>40.5</td> <td>45</td> </tr> <tr> <td>0x83</td> <td>MCS 3</td> <td>1</td> <td>54</td> <td>60</td> </tr> <tr> <td>0x84</td> <td>MCS 4</td> <td>1</td> <td>81</td> <td>90</td> </tr> <tr> <td>0x85</td> <td>MCS 5</td> <td>1</td> <td>108</td> <td>120</td> </tr> <tr> <td>0x86</td> <td>MCS 6</td> <td>1</td> <td>121.5</td> <td>135</td> </tr> <tr> <td>0x87</td> <td>MCS 7</td> <td>1</td> <td>135</td> <td>150</td> </tr> <tr> <td>0x88</td> <td>MCS 8</td> <td>2</td> <td>27</td> <td>30</td> </tr> <tr> <td>0x89</td> <td>MCS 9</td> <td>2</td> <td>54</td> <td>60</td> </tr> <tr> <td>0x8A</td> <td>MCS 10</td> <td>2</td> <td>81</td> <td>90</td> </tr> <tr> <td>0x8B</td> <td>MCS 11</td> <td>2</td> <td>108</td> <td>120</td> </tr> <tr> <td>0x8C</td> <td>MCS 12</td> <td>2</td> <td>162</td> <td>180</td> </tr> <tr> <td>0x8D</td> <td>MCS 13</td> <td>2</td> <td>216</td> <td>240</td> </tr> <tr> <td>0x8E</td> <td>MCS 14</td> <td>2</td> <td>243</td> <td>270</td> </tr> <tr> <td>0x8F</td> <td>MCS 15</td> <td>2</td> <td>270</td> <td>300</td> </tr> </tbody> </table>	Value ^[1]	Desc	Stream	HT20/HT40 GI = 0 (Mbps)	HT20/HT40 GI = 1 (Mbps)	0x80	MCS 0	1	13.5	15	0x81	MCS 1	1	27	30	0x82	MCS 2	1	40.5	45	0x83	MCS 3	1	54	60	0x84	MCS 4	1	81	90	0x85	MCS 5	1	108	120	0x86	MCS 6	1	121.5	135	0x87	MCS 7	1	135	150	0x88	MCS 8	2	27	30	0x89	MCS 9	2	54	60	0x8A	MCS 10	2	81	90	0x8B	MCS 11	2	108	120	0x8C	MCS 12	2	162	180	0x8D	MCS 13	2	216	240	0x8E	MCS 14	2	243	270	0x8F	MCS 15	2	270	300
			Value ^[1]	Desc	Stream	HT20/HT40 GI = 0 (Mbps)	HT20/HT40 GI = 1 (Mbps)																																																																																	
			0x80	MCS 0	1	13.5	15																																																																																	
			0x81	MCS 1	1	27	30																																																																																	
			0x82	MCS 2	1	40.5	45																																																																																	
			0x83	MCS 3	1	54	60																																																																																	
			0x84	MCS 4	1	81	90																																																																																	
			0x85	MCS 5	1	108	120																																																																																	
			0x86	MCS 6	1	121.5	135																																																																																	
			0x87	MCS 7	1	135	150																																																																																	
			0x88	MCS 8	2	27	30																																																																																	
			0x89	MCS 9	2	54	60																																																																																	
			0x8A	MCS 10	2	81	90																																																																																	
			0x8B	MCS 11	2	108	120																																																																																	
			0x8C	MCS 12	2	162	180																																																																																	
			0x8D	MCS 13	2	216	240																																																																																	
			0x8E	MCS 14	2	243	270																																																																																	
			0x8F	MCS 15	2	270	300																																																																																	
			15:8	tx_rate1	Tx rate for transmission series 1. See the rate table in “tx_rate0”.																																																																																			
			23:16	tx_rate2	Tx rate for transmission series 2. See the rate table in “tx_rate0”.																																																																																			
31:24	tx_rate3	Tx rate for transmission series 3. See the rate table in “tx_rate0”.																																																																																						
6	14:0	packet_duration0	Packet duration 0 (in μ s) Duration of the actual Tx frame associated with TXRate0. This time does not include RTS, CTS, ACK, or any associated SIFS.																																																																																					
	15	rts_cts_qual0	Qualifies “rts_enable” or “cts_enable” in the Tx descriptor for Tx series 0.																																																																																					
			1 Default behavior with respect to “rts_enable” and “cts_enable”																																																																																					
	30:16	packet_duration1	Packet duration 1 (in μ s) Duration of the actual Tx frame associated with TXRate1. This time does not include RTS, CTS, ACK, or any associated SIFS.																																																																																					
	31	rts_cts_qual1	Qualifies “rts_enable” or “cts_enable” in the Tx descriptor for Tx series 1.																																																																																					
1 Default behavior with respect to “rts_enable” and “cts_enable”																																																																																								

Table 3-2. Tx Control Descriptor Format (Words 2–13) (continued)

Word	Bits	Field Name	Description		
7	14:0	packet_duration2	Packet duration 2 (in μ s) Duration of the actual Tx frame associated with TXRate2. This time does not include RTS, CTS, ACK, or any associated SIFS.		
	15	rts_cts_qual2	Qualifies “rts_enable” or “cts_enable” in the Tx descriptor for Tx series 2.		
			1 Default behavior with respect to “rts_enable” and “cts_enable”		
	30:16	packet_duration3	Packet duration 3 (in μ s) Duration of the actual Tx frame associated with TXRate3. This time does not include RTS, CTS, ACK, or any associated SIFS.		
	31	rts_cts_qual3	Qualifies “rts_enable” or “cts_enable” in the Tx descriptor for Tx series 3.		
			1 Default behavior with respect to “rts_enable” and “cts_enable”		
8	15:0	agg_length	Aggregate length		
	17:16	RES	Reserved		
	25:18	pad_delim	Number of delimiters to add at the end of a packet. The encryption field must be valid for all descriptions.		
	28:26	encrypt_type	Encryption type		
			0	None	0 pad bytes
			1	WEP	4 pad bytes
2			AES	8 pad bytes	
	3	TKIP	12 pad bytes		
31:29	RES	Reserved			

Table 3-2. Tx Control Descriptor Format (Words 2–13) (continued)

Word	Bits	Field Name	Description	
9	0	20_40_0	20_40 control for Tx series 0	
			0	HT20 Tx packet
			1	HT40 Tx packet
1	1	GI_0	Guard interval control for Tx series 0	
			0	Normal guard interval
			1	Short guard interval
4:2	chain_sel_0	Chain select for Tx series 0. 1, 2, and 3 are the only valid values.		
		Bit [0]	Chain 0 is active	
		Bit [1]	Chain 1 is active	
		Bit [2]	Reserved	
5	20_40_1	20_40 control for Tx series 1		
		0	HT20 Tx packet	
		1	HT40 Tx packet	
6	1	GI_1	Guard interval control for Tx series 1	
			0	Normal guard interval
			1	Short guard interval
9:7	chain_sel_1	Chain select for Tx series 1. 1, 2, and 3 are the only valid values.		
		Bit [0]	Chain 0 is active	
		Bit [1]	Chain 1 is active	
		Bit [2]	Reserved	

Table 3-2. Tx Control Descriptor Format (Words 2–13) (continued)

Word	Bits	Field Name	Description	
9 (cont.)	10	20_40_2	20_40 control for Tx series 2	
			0	HT20 Tx packet
			1	HT40 Tx packet
	11	GI_2	Guard interval control for Tx series 2	
			0	Normal guard interval
			1	Short guard interval
	14:12	chain_sel_2	Chain select for Tx series 2. 1, 2, and 3 are the only valid values.	
			Bit [0]	Chain 0 is active
			Bit [1]	Chain 1 is active
			Bit [2]	Reserved
	15	20_40_3	20_40 control for Tx series 3	
			0	HT20 Tx packet
			1	HT40 Tx packet
	16	GI_3	Guard interval control for Tx series 3	
			0	Normal guard interval
			1	Short guard interval
	19:17	chain_sel_3	Chain select for Tx series 3. 1, 2, and 3 are the only valid values.	
			Bit [0]	Chain 0 is active
			Bit [1]	Chain 1 is active
			Bit [2]	Reserved
	27:20	rts_cts_rate	RTS or self-CTS rate selection Specifies the rate at which the RTS will send if “rts_enable” is set, or at which self CTS will send if cts_enable is set. See the rate table in “tx_rate0”.	
31:28	stbc	The STBC settings for all four series If bit 0 is set, STBC is enabled for Tx series 0, etc. Only the lower bit of the two-bit STBC will be set because STBC is only supported for single stream.		
10	23:0	antenna_0	Antenna switch for Tx series 0	
	31:24	RES	Reserved	
11	23:0	antenna_1	Antenna switch for Tx series 1	
	29:24	tpc_1	Tx power control (TPC) for Tx series 1	
	31:30	RES	Reserved	
12	23:0	antenna_2	Antenna switch for Tx series 2	
	29:24	tpc_2	Tx power control (TPC) for Tx series 2 These bits pass unchanged to the baseband to control Tx power for the frame.	
	31:30	RES	Reserved	
13	23:0	antenna_3	Antenna switch for Tx series 3	
	29:24	tpc_3	Tx power control (TPC) for Tx series 3 These bits pass unchanged to the baseband to control Tx power for the frame.	
	31:30	RES	Reserved	

The Tx descriptor format for words 14 through 23 is described in [Table 3-3](#).

Table 3-3. Tx Status Descriptor Format (Words 14–23)

Word	Bits	Field Name	Description
14	7:0	rss_i_ant00	Rx ACK signal strength indicator of control channel chain 0. A value of 0x80 (–128) indicates an invalid number.
	15:8	rss_i_ant01	Rx ACK signal strength indicator of control channel chain 1. A value of 0x80 (–128) indicates an invalid number.
	23:16	RES	Reserved
	29:24	RES	Reserved
	30	ba_status	Block ACK status If set this bit indicates that the ba_bitmap values are valid.
	31	RES	Reserved

Table 3-3. Tx Status Descriptor Format (Words 14–23) (continued)

Word	Bits	Field Name	Description	
15	0	frm_xmit_ok	Frame transmission success	
			set	The frame was transmitted successfully
			clear	No ACK or BA was received during frame transmission
	1	excessive_retries	Excessive tries If set, transmission of the frame failed because the try limit was reached before the frame was transmitted successfully. Valid only for the final descriptor of a frame, and only if “frm_xmit_ok” is clear.	
	2	fifo_underrun	Tx FIFO underrun flag If set, frame transmission failed because the DMA engine was not able to supply the PCU with data as quickly as the baseband was requesting data. Valid only for non-aggregate or non-RIFS underrun conditions unless the underrun occurred on the first packet of the aggregate or RIFS burst. See also the description for “tx_dlmtr_underrun_err” and “tx_data_underrun_err”. Valid only if “frm_xmit_ok” is clear.	
	3	filtered	Frame transmission filter indication If set, indicates that frame was not transmitted because the corresponding destination mask bit was set when the frame reached the PCU, or the frame violated TXOP on the first packet of a burst. Valid if “frm_xmit_ok” is clear.	
	7:4	rts_fail_cnt	RTS failure count Reports the number of times an RTS was sent but no CTS was received for the final transmission series (see “final_tx_index”). For frames with “rts_enable” clear, this count is always zero. Note that this count increments only when the RTS/CTS exchange fails. In particular, this count does not increment if the RTS/CTS exchange succeeds but the frame itself fails because no ACK was received. Valid only for the final descriptor of a frame, regardless of the state of “frm_xmit_ok”.	
11:8	data_fail_cnt	Data failure count Reports the number of times the actual frame (as opposed to the RTS) was sent but no ACK was received for the final transmission series (see “final_tx_index”). Valid only for the final descriptor of a frame, regardless of the state of “frm_xmit_ok”.		
15:12	virtual_retry_cnt	Virtual collision count Reports the number of virtual collisions that occurred before transmission of the frame ended. The counter value saturates at 0xF. A virtual collision refers to the case, as described in the 802.11e QoS specification, in which two or more output queues contend for a TXOP simultaneously. In such cases, all lower-priority output queues experience a “virtual collision” in which the frame is treated as if it had been sent on the air but failed to receive an ACK.		
16	tx_dlmtr_underrun_err	Tx delimiter underrun error This error only occurs on aggregate frames when the underrun conditions happens while the MAC is sending delimiters.		

Table 3-3. Tx Status Descriptor Format (Words 14–23) (continued)

Word	Bits	Field Name	Description
15 (cont.)	17	tx_data_underrun_err	Tx data underrun error. This error only occurs on aggregate frames when the underrun condition happens while the MAC is sending the data portion of the frame or delimiters.
	18	desc_config_error	Descriptor configuration error. This error occurs if the current 20_40 values are not among the four valid combinations, or if “tx_dlmtr_underrun_err” or “tx_data_underrun_err” are set.
	19	tx_timer_expired	Tx timer expired. This bit is set when the Tx frame takes longer to send to the baseband than is allowed based on the TX_TIMER register. Some regulatory domains require that Tx packets may not exceed a certain amount of transmit time.
	31:20	RES	Reserved
16	31:0	send_timestamp	Timestamp at the start of transmit. A snapshot of the lower 32 bits of PCU's timestamp (TSF value). This field can aid the software driver in implementing requirements associated with the aMaxTransmitMSDULifetime MAC attribute. The Tx timestamp is sampled upon tx_frame signal rising that goes from the MAC to the baseband. This value corresponds to the last attempt at packet transmission (not the first attempt).
17	31:0	ba_bitmap_0-31	Block ACK bitmap 0 to 31. The values from the block that ACK received after successful transmission of an aggregate frame. Bit 0 if set represents the successful reception of the packet with the sequence number matching the seq_num value.
18	31:0	ba_bitmap_32-63	Block ACK bitmap 32 to 63. The values from the block that ACK received after successful transmission of an aggregate frame. Bit 0 if set represents the successful reception of the packet with the sequence number matching seq_num + 32.
19	7:0	rss_i_ant10	Receive ACK signal strength indicator of extension channel chain 0. A value of 0x80 (–128) indicates an invalid number.
	15:8	rss_i_ant11	Receive ACK signal strength indicator of extension channel chain 1. A value of 0x80 (–128) indicates an invalid number.
	23:16	RES	Reserved
	31:24	ack_rssi_combined	Receive ACK signal strength indicator of combination of all active chains on the control and extension channels. The value of 0x80 (–128) is used to indicate an invalid number.
20	31:0	EVM	Error vector magnitude 0. EVM is not calculated for legacy frames so this value should always be 0x80 because ACK/BA should be sent at legacy rates.
21	31:0	EVM	Error vector magnitude 1. EVM is not calculated for legacy frames so this value should always be 0x80 because ACK/BA should be sent at legacy rates.
22	31:0	EVM	Error vector magnitude 2. EVM is not calculated for legacy frames so this value should always be 0x80 because ACK/BA should be sent at legacy rates.

Table 3-3. Tx Status Descriptor Format (Words 14–23) (continued)

Word	Bits	Field Name	Description
23	0	done	Descriptor completion flag. Set to one by the DMA engine when it has finished processing the descriptor and has updated the status information. Valid only for the final descriptor of a frame, regardless of the state of "frm_xmit_ok". The driver is responsible for tracking what descriptors are associated with a frame. When the DMA engine sets the Done flag in the final descriptor of a frame, the driver must be able to determine what other descriptors belong to the same frame and thus also have been consumed.
	12:1	SeqNum	Tx sequence number. Indicates the sequence number from the response block ACK. This field should only be consulted if the Tx frame was an aggregate. Because hardware does not update the sequence number, this field does not need to be consulted for non-aggregate frames. For aggregates, this sequence number may not be the sequence number of the first Tx frame of the aggregate. More than likely has an older sequence number if the hardware of the other side keeps track of prior sequence numbers. It may sometimes have a newer sequence number if the first packet of the aggregate failed.
	16:13	RES	Reserved
	17	txop_exceeded	TXOP has been exceeded. Indicates that this Tx frame had to be filtered because the amount of time to transmit this packet sequence would exceed the TXOP limit (which should only occur when software programs the TXOP limit improperly).
	20:18	RES	Reserved
	22:21	final_tx_index	Final transmission attempt series index. Specifies the number of the Tx series that caused frame transmission to terminate.
	24:23	RES	Reserved
	25	pwr_mgmt	Power management state. Indicates the value of the power management bit in the frame control field of the response ACK frame.
	27:26	RES	Reserved
	31:28	tid	Traffic identifier of block ACK. This field indicates the TID of the response block ACK. This field is only valid on the last descriptor of the last packet of an aggregate.

The DMA Rx logic (the DRU block) manages Rx descriptors and transfers the incoming frame data and status to the host through the PCI Express Interface. The Rx descriptor format for words 2 and 3 is described in [Table 3-4](#).

Table 3-4. Rx Control Descriptor Format (Words 2–3)

Word	Bits	Field Name	Description	
2	31:0	RES	Reserved	
3	11:0	buf_len	Data buffer length (in bytes). Specifies the length of the data buffer associated with this descriptor. Rx data buffers must have a length that is an integral multiple of four bytes.	
	12	RES	Reserved	
	13	int_req	Interrupt request flag. Indicates whether the DMA engine should generate an interrupt upon frame completion.	
			0	Do not generate an InterReq interrupt upon frame completion
			1	Generate an InterReq interrupt upon frame completion
31:14	RES	Reserved		

The Rx descriptor format for words 4 through 12 is described in [Table 3-5](#).

Table 3-5. Rx Status Descriptor Format (Words 4–12)

Word	Bits	Field Name	Description
4	7:0	rss_i_ant00	Receive signal strength indicator of control channel chain 0. A value of 0x80 (–128) indicates an invalid number.
	15:8	rss_i_ant01	Receive signal strength indicator of control channel chain 1. A value of 0x80 (–128) indicates an invalid number.
	23:16	RES	Reserved
	31:24	rx_rate	Rx rate indication. Indicates the rate at which this frame transmits from the source. Encodings match those used for the tx_rate_* field in word 5 of the Tx descriptor. Valid only if “frame_rx_ok” is set, or if it is clear and the “phy_error” flag is clear.

Table 3-5. Rx Status Descriptor Format (Words 4–12) (continued)

Word	Bits	Field Name	Description	
5	11:0	data_len	Received data length Specifies the length, in bytes, of the data actually received into the data buffer associated with this descriptor. The actual received data length is between zero and the total size of the data buffer, as specified originally in this field (see the description for “buf_len”). Valid for all descriptors.	
	12	more	More descriptors in this frame flag If set, then this is not the final descriptor of the frame. If clear, this descriptor is the final one of the frame. Valid for all descriptors.	
			0	No more descriptors for the current frame
		1	The current frame is continued in the next descriptor	
	13	RES	Reserved	
21:14	num_delim	Number of zero length pad delimiters after current packet This field does not include the start delimiter required between each packet in an aggregate. This field is only valid for aggregate packets except for the last packet of an aggregate		
		31:22	RES	Reserved
6	31:0	rcv_timestamp	A snapshot of the PCU's timestamp (TSF value) (in ms) Bits [31:0] of the PCU's 64-bit TSF. Intended for packet logging and packet sniffing. The timestamp is sampled on the rising edge of rx_clear, which goes from the baseband to the MAC.	
			7	0
1	20_40	Rx packet 20 or 40 MHz bandwidth indicator. If this value is clear, the Rx frame was a HT20 packet (20 MHz bandwidth). If this value is set, then the receive frame was a HT40 packet (40 MHz bandwidth).		
2	duplicate	Rx packet duplicate indicator. If this value is set, the baseband has determined that this packet is a duplicate packet.		
7:3	RES	Reserved		
31:8	rx_antenna	Rx antenna value		
8	7:0	rss_i_ant10	Receive signal strength indicator of control channel chain 0. A value of 0x80 (–128) indicates an invalid number.	
	15:8	rss_i_ant11	Receive signal strength indicator of control channel chain 1. A value of 0x80 (–128) indicates an invalid number.	
	23:16	RES	Reserved	
	31:24	rss_i_combined	Rx signal strength indicator of combination of all active chains on the control and extension channels. The value of 0x80 (–128) is used to indicate an invalid number.	
9	31:0	EVM	Rx packet error vector magnitude 0.	
10	31:0	EVM	Rx packet error vector magnitude 1.	
11	31:0	EVM	Rx packet error vector magnitude 2.	

Table 3-5. Rx Status Descriptor Format (Words 4–12) (continued)

Word	Bits	Field Name	Description	
12	0	done	Descriptor completion flag Set to one by the DMA engine when it has finished processing the descriptor and has updated the status information. Valid for all descriptors.	
			0	The MAC has not finished processing the descriptor. Valid only for the final descriptor of a frame
			1	The MAC has finished processing the descriptor and has updated the status information
1	frame_rx_ok	frame_rx_ok	Frame reception success flag If set, the frame was received successfully. If clear, an error occurred during frame reception.	
			0	An error occurred during frame reception
			1	Frame received successfully
2	crc_error	crc_error	Cyclic redundancy code (CRC) error flag Valid only for the final descriptor of a frame, and only if the “frame_rx_ok” flag is clear.	
			0	Frame received without a CRC error
			1	Reception of frame failed because of an incorrect CRC value
3	decrypt_crc_err	decrypt_crc_err	Decryption CRC failure flag. Valid only for the final descriptor of a frame, and only if the FrmRcvOK flag is clear.	

Table 3-5. Rx Status Descriptor Format (Words 4–12) (continued)

Word	Bits	Field Name	Description
12 (cont.)	4	phy_error	PHY error flag. If set, then reception of the frame failed because the PHY encountered an error. In this case, bits [15:8] of this word indicate the specific type of PHY error; see the baseband specification for details. Valid only if the 'frame_rx_ok' flag is clear.
	5	mic_error	Michael integrity check error flag. If set, then the frame's TKIP Michael integrity check value did not verify correctly. Valid only when all of the following are true: <ul style="list-style-type: none"> ■ The "frame_rx_ok" bit is clear ■ The frame was decrypted using TKIP ■ The frame is not a fragment
	6	pre_delim_crc_err	Delimiter CRC error detected before this current frame
	7	RES	Reserved
	8	key_idx_valid	<ul style="list-style-type: none"> ■ If "frame_rx_ok" is set, then this field contains the decryption key table index valid flag. If set, indicates that the PCU successfully located the frame's source address in its on-chip key table and that the KeyIdx field reflects the table index at which the destination address was found. If clear, indicates that the PCU failed to locate the destination address in the key table and that the contents of KeyIdx field are undefined. ■ If "frame_rx_ok" is clear and the "phy_error" bit is set, then this field contains bit [0] of the PHY error code. In both cases, this field is valid only for the final descriptor of a frame.
	15:9	key_idx	<ul style="list-style-type: none"> ■ If "frame_rx_ok" is set, then this field contains the decryption key table index valid flag. If set, indicates that the PCU successfully located the frame's source address in its on-chip key table and that the KeyIdx field reflects the table index at which the destination address was found. If clear, indicates that the PCU failed to locate the destination address in the key table and that the contents of KeyIdx field are undefined. ■ If "frame_rx_ok" is clear and the "phy_error" bit is set, then this field contains bits [4:1] of the PHY error code, the upper three bits are zero. In both cases, this field is valid only for the final descriptor of a frame.
	16	more_agg	More aggregate flag. This bit is only set for the last descriptor of the last packet of an aggregate.
	17	aggregate	Aggregate flag. If set indicates that this packet is part of an aggregate.
	18	post_delim_crc_err	Delimiter CRC error detected after this current frame. Only occurs when the start delimiter of the last frame in an aggregate is bad.
	27:19	RES	Reserved
	28	hi_rx_chain	If set indicates that the Rx chain control in high power mode.
	29	first_agg	First packet of aggregate. If set indicates that this packet is the first packet of an aggregate.
	30	decrypt_busy_err	Decrypt busy error. If set it indicates new frame arrived before decryption completed for the previous frame.
	31	key_miss	Key cache miss indication. If set, indicates that the PCU could not locate a valid description key for the frame. Valid only if the "frame_rx_ok" is clear.

3.4 Queue Control Unit (QCU)

The queue control unit performs two tasks:

- Managing the Tx descriptor chain processing for frames pushed to the QCU from the host by traversing the linked list of Tx descriptors and transferring frame data from the host to the targeted DCU.
- Managing the queue Tx policy to determine when the frame at the head of the queue should be marked as available to transmit.

The MAC contains ten QCUs, each with all the logic and state registers needed to manage a single queue (linked list) of Tx descriptors. A QCU is associated with exactly one DCU. When a QCU prepares a new frame, it signals ready to the DCU. When the DCU accepts the frame, the QCU responds by getting the frame data and passing it to the DCU for eventual transmission to the PCU and on to the air. The host controls how the QCU performs these tasks by writing to various QCU configuration registers (see “QCU Registers” on page 70).

3.4.1 DCF Control Unit (DCU)

Collectively, the ten DCUs implement the EDCF channel access arbitration mechanism defined in the Task Group E (TGe) QoS extension to the 802.11 specification. Each DCU is associated with one of the eight EDCF priority levels and arbitrates with the other DCUs on behalf of all QCUs associated with it. A central DCU arbiter monitors the state of all DCUs and grants one the next access to the PCU (that is, access to the channel).

Because the EDCF standard defines eight priority levels, the first eight DCUs (DCUs 0–7) map directly to the eight EDCF priority levels. The two additional DCUs handle beacons and beacon-gated frames for a total of ten DCUs.

The mapping of physical DCUs to absolute channel access priorities is fixed and cannot be altered by software:

The highest-priority DCU is DCU 9. Typically, this DCU is the one associated with beacons. The next highest priority DCU is DCU 8. Typically, this DCU is the one associated with beacon-gated frames. The remaining eight DCUs priority levels are filled with DCUs 7 through 0. Among these 8 DCUs, DCU 7 has highest priority, DCU 6 the next highest priority, and so on through DCU 0, which has the lowest priority. Typically, these DCUs are associated with EDCF priorities seven through zero, respectively.

3.5 Protocol Control Unit (PCU)

The PCU is responsible for the details of sending a frame to the baseband logic for transmission, for receiving frames from the baseband logic and passing the frame data to the DRU, including:

- Buffering Tx and Rx frames
- Encrypting and decrypting
- Generating ACK, RTS, and CTS frames
- Maintaining the timing synchronization function (TSF)
- Inserting and verifying FCS
- Generating virtual clear channel assessment (CCA)
- Updating and parsing beacons
- The PCU is primarily responsible for buffering outgoing and incoming frames and conducting medium access compatible with the IEEE 802.11 DCF protocol.

Figure 3-2 shows the PCU functional block diagram.

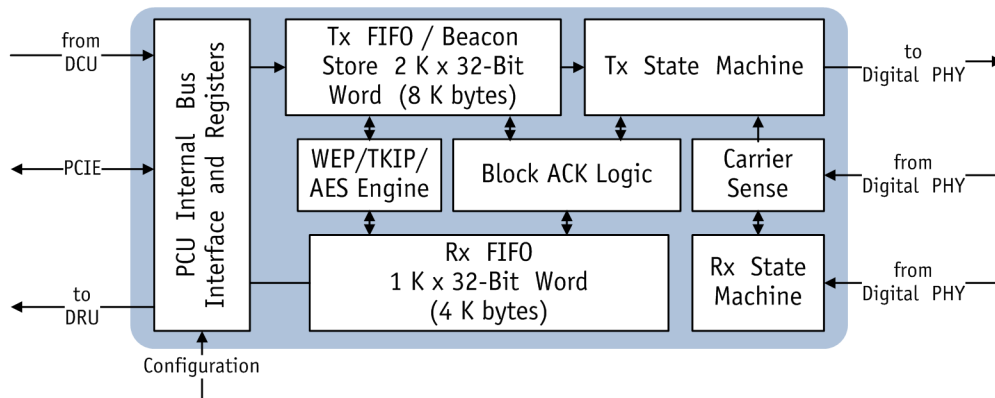

Figure 3-2. PCU Functional Block Diagram

4. Digital PHY Block

The digital physical layer (PHY) block is described in 802.11 draft-n mode and 802.11b/g legacy mode. Transmit and receive paths are provided and shown as block diagrams for 802.11 draft-n mode.

4.1 Overview

The digital PHY block is a half-duplex, OFDM, CCK, DSSS baseband processor compatible with IEEE 802.11n and 802.11b/g. The AR9287 supports PHY data rates up to 300 Mbps in 20- and 40-MHz channel modes and all data rates defined by the IEEE 802.11b/g standard (1–54Mbps). Modulation schemes include BPSK, QPSK, 16-QAM, 64-QAM and forward error correction coding with rates of 1/2, 2/3, 3/4, 5/6.

4.2 802.11n (MIMO) Mode

Frames beginning with training symbols are used for signal detection, automatic gain control, frequency offset estimation, symbol timing, and channel estimation. This process uses 56 sub-carriers for 20-MHz HT mode: 52 for data transmission and 4 for pilots. It uses 114 sub-carriers for 40-MHz HT mode: 108 for data transmission and 6 for pilots.

4.2.1 Transmitter (Tx)

Figure 4-1 shows the Tx path digital PHY 802.11n (MIMO mode) block diagram.

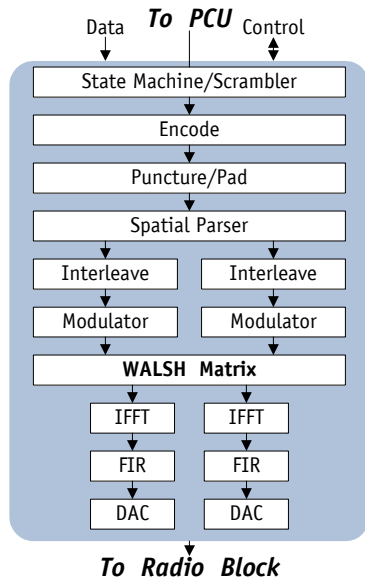

Figure 4-1. Digital PHY 802.11n Tx

The PCU block initiates transmission. The digital PHY powers on the digital to analog converter (DAC) and transmit portions of the AR9287. The training symbols are a fixed waveform and are generated within the digital PHY in parallel with the PCU sending the Tx header (frame length, data rate, etc.). The PCU must send transmitted data quickly enough to prevent buffers in the digital PHY from becoming empty. The PCU is prevented from sending data too quickly by pauses generated within the digital PHY.

Figure 4-1 shows a 2x2 MIMO system with two spatial data streams. The spatial parser splits the coded data into multiple data streams by allocating the proper number of bits to each data stream so that the number of data symbols resulted in each stream is the same. Then it interleaves coded bits across different data subcarriers followed by the modulation. To achieve the maximum spatial diversity, the Walsh matrix orthogonally separates the two modulated streams into three before the streams undergo IFFT processing to produce time domain signals.

4.2.2 Receiver (Rx)

Figure 4-2 shows the Rx path digital PHY 802.11n (MIMO mode) block diagram.

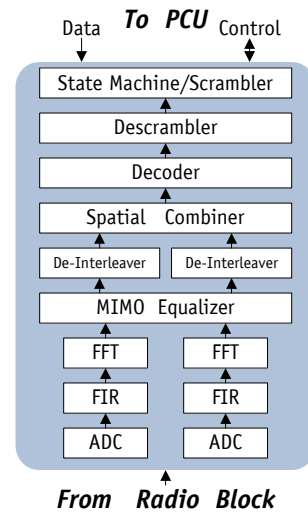

Figure 4-2. Digital PHY 802.11n Rx

The receiver inverts the transmitter's steps, performing a fast fourier transform (FFT), extracting bits from received constellations, de-interleaving, accounting for puncturing, decoding, and descrambling. The Rx block shows 2x2 MIMO configuration. Figure 4-2 shows a frequency-domain equalizer handling degradation due to multi-path.

4.3 802.11b/g Legacy Mode

4.3.1 Transmitter

The AR9287 digital PHY incorporates an OFDM and DSSS transceiver that supports all data rates defined by IEEE 802.11b/g. Legacy mode is detected on per-frame basis. PLCP frames are detected for legacy network information. The transmitter switches dynamically to generate legacy signals.

4.3.2 Receiver

The receiver is capable of dynamically detecting legacy, HT 20 MHz or 40 MHz frames and will demodulate the frame according to the detected frame type.

5. Radio Block

The transceiver of the AR9287 solution consists of these major functional blocks:

- 2 x Receive chain
Each chain = Radio + BB programmable gain filter
- 2 x Transmit chain
Each chain = Radio + BB programmable gain filter
- Frequency synthesizer (SYNTH)
- Associated bias/control (BIAS)

See Figure 5-1.

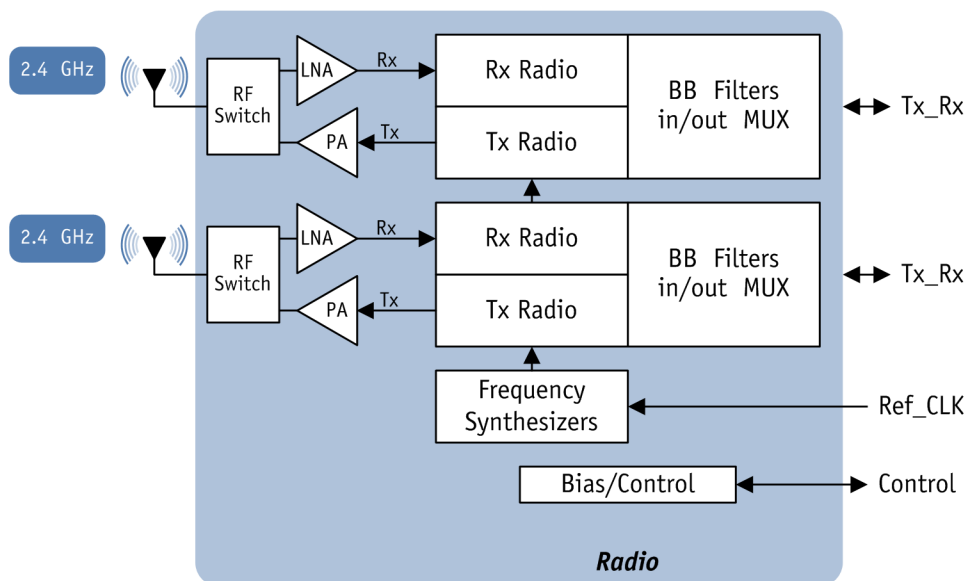

Figure 5-1. Radio Functional Block Diagram

5.1 Receiver (Rx) Block

The receiver converts an RF signal (with 20 MHz or 40 MHz bandwidth) to baseband I and Q outputs. The dual band receiver operates in the 2.4 GHz bands to support CCK and OFDM signals for 802.11b, 802.11g, and 802.11n.

The 2.4 GHz receiver implements a direct conversion architecture.

The receiver consists of a low noise amplifier (LNA), in-phase (I) and quadrature (Q) radio frequency mixers, and a baseband programmable gain amplifier (PGA). The mixer converts the output of the on-chip LNA to baseband I and Q signals. The I and Q signals are low-pass filtered and amplified by a baseband programmable gain filter controlled by digital logic. The baseband signals are sent to the ADC within the MAC/Baseband processor.

The DC offset of the receive chain is reduced using multiple DACs controlled by the MAC/Baseband processor. Additionally, the receive chain can be digitally powered down to conserve power.

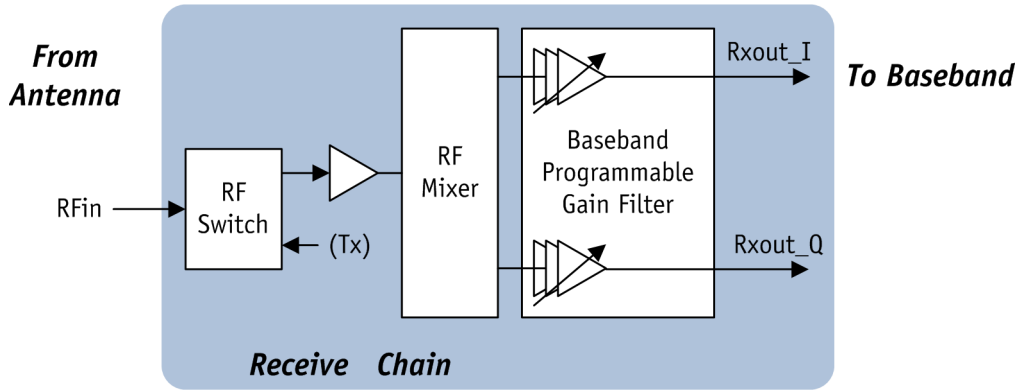

Figure 5-2. Radio Receive Chain Block Diagram

5.2 Transmitter (Tx) Block

The transmitter converts baseband I and Q inputs to 2.4 GHz RF outputs as shown in Figure 5-3. The inputs to the transmitter are current outputs of the DAC within the MAC/Baseband processor. These currents are low-pass filtered through an on-chip reconstruction filter to remove spectral images and out-of-band quantization noise.

The I and Q signals are converted to RF signals using an integrated up-conversion architecture. The baseband I and Q signals are up-converted directly to RF using a pair of quadrature mixers. These signals are driven off-chip through a power amplifier.

The transmit chain can be digitally powered down to conserve power. To ensure that the FCC limits are observed and the output power stays close to the maximum allowed, the transmit output power is adjusted by a digitally programmed control loop at the start of each packet. The AR9287 provides an open loop power control based on an on-chip temperature sensor.

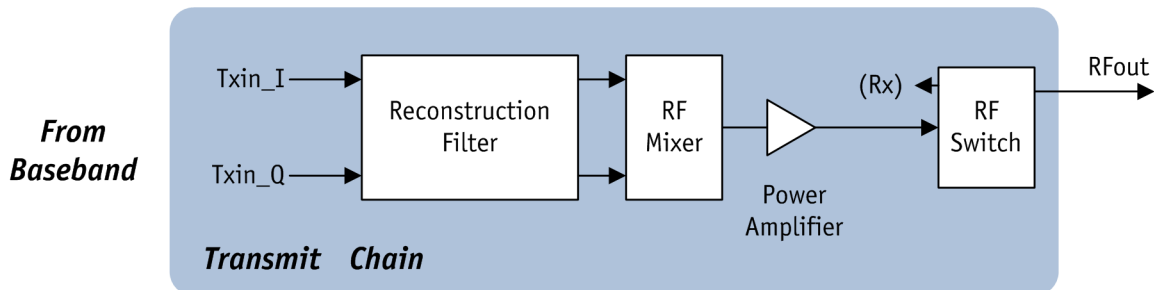

Figure 5-3. Radio Transmit Chain Block Diagram

5.3 Synthesizer (SYNTH) Block

The radio supports one on-chip synthesizer to generate local oscillator (LO) frequencies for the receiver and transmitter mixers. The synthesizer has the topology shown in Figure 5-4.

The AR9287 generates the reference input from a 40 MHz crystal for the synthesizer. An on-chip voltage controlled oscillator (VCO) provides the desired LO signal based on a phase/frequency locked loop.

Upon power up or channel reselection, the synthesizer takes approximately 0.2 ms to settle.

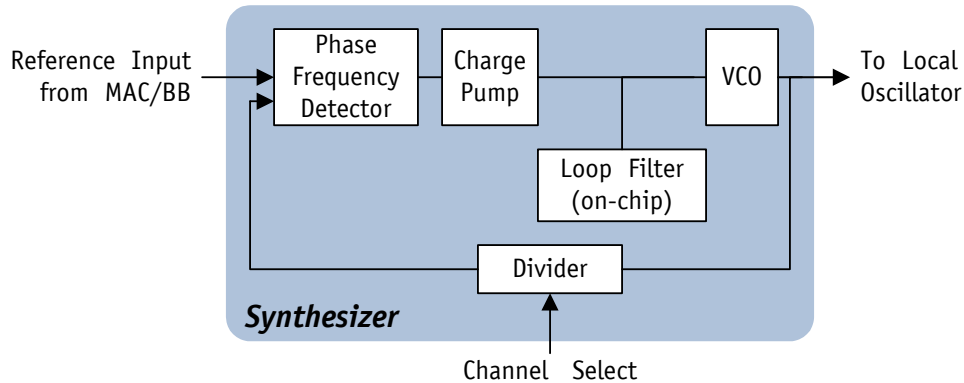

Figure 5-4. Radio Synthesizer Block Diagram

5.4 Bias/Control (BIAS) Block

The bias/control block provides the reference voltages and currents for all other circuit blocks (see Figure 5-5). An on-chip bandgap reference circuit provides the needed voltage and current references based on an external 6.19 K Ω \pm 1% resistor.

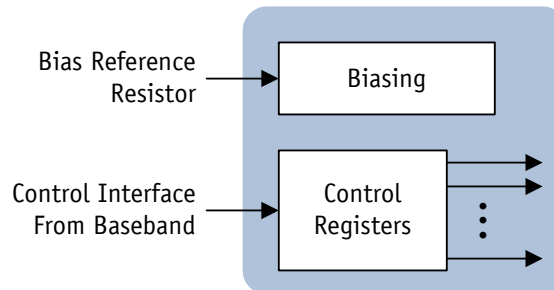

Figure 5-5. Bias/Control Block Diagram

6. LDO Circuit Recommendation

The AR9287 can be powered by an optional on-chip LDO. Along with an external PNP, this block provides a regulated 1.2 V power supply for the rest of the AR9287. Figure 6-1 displays an example circuit for the AR9287 low dropout regulator.

NOTE: The partial LDO option provides a cost advantage over DC-to-DC converter, however, care must be taken to ensure proper heat sinking through good board design or a heat sink is placed over the chip.

If the on-chip LDO is not used, the XPNPB pin should be pulled down to ground by 10 K Ω resistor to disable the internal amplifier.

6.1 PNP Transistor

When selecting the PNP transistor, power dissipation of the transistor should be considered. The PNP collector can be connected to a series resistor (R) for sharing the load of power dissipation with the PNP. The size of the resistor depends on the power rating. For example, it can be a 2.2 Ω or two 4.7 Ω resistors connected in parallel between the collector and the capacitor. The LDO should provide power to the AR9287 only.

Refer to the reference design schematic.

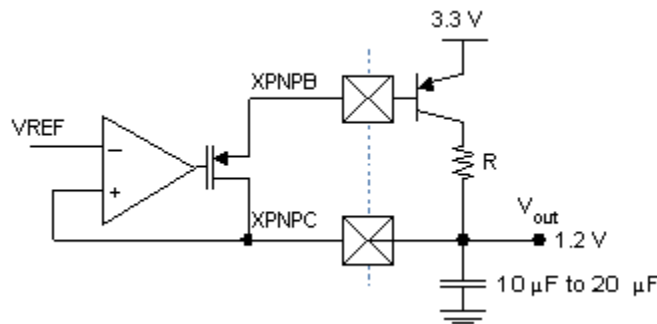

Figure 6-1. AR9287 Low Dropout Regulator

7. Register Descriptions

This section describes the PCI Express Configuration Space registers and internal registers for the various blocks of the AR9287. The AR9287 internal registers are mapped to the memory space of the host by specifying the base address in the configuration space.

The internal registers are divided into the following groups:

- “Beacon Handling” on page 68
- “Wake-on-Wireless Register” on page 129
- “QCU Registers” on page 70
- “DCU Registers” on page 76
- “EEPROM Interface Registers” on page 87
- “Host Interface Registers” on page 87
- “RTC Interface Registers” on page 99
- “MAC PCU Registers” on page 103

7.1 PCI Express Configuration Space Registers

Table 7-1 summarizes the AR9287 PCI Express configuration space registers. The offset column refers to the offset from the base address configured by the host. The host accesses these registers at boot time to detect the type of card present and to perform low-level configuration, such as assigning the base address to the card. At reset, an off-chip serialized EEPROM initializes some registers, while the host or the AR9287 hardware must program the others.

See version 1.1 of the PCI Express standard for detailed information on these registers.

Table 7-1. PCI Express Configuration Space Register Summary

Offset	NAME	Description	Initialized by	Page
0x00	VENDOR ID	Manufacturer Identification	EEPROM	page 38
0x02	DEVICE ID	Device Type Identification	EEPROM	page 38
0x04	COMMAND	Device Accessibility Control	Host	page 39
0x06	STATUS	Device Functionality Status	AR9287	page 40
0x08	REVISION ID	Device Revision Identification	EEPROM	page 40
0x09	CLASS CODE	Device Basic Function Identification	EEPROM	page 41
0x0C	CACHE LINE SIZE	System Cache Line Size	Host	page 41
0x0D	LATENCY TIMER	Defines Minimum Time (in bus cycles) the Bus Master Can Retain Ownership of the Bus	Host	page 41
0x0E	HEADER TYPE	Device Configuration Header Format	EEPROM	page 41
0x0F	RES	Reserved	—	—
0x10	BASE ADDRESS	Base Address to Access WLAN Memory Mapped Registers	Host	page 41
0x14–0x28	RES	Reserved	—	—
0x2C	SUBSYSTEM VENDOR ID	Subsystem Manufacturer Identification	EEPROM	page 42
0x2E	SUBSYSTEM ID	Subsystem Device Type Identification	EEPROM	page 42
0x34	CAPABILITIES POINTER	Device Capability List Pointer	AR9287	page 42
0x38–0x3C	RES	Reserved	—	—
0x3D	INTERRUPT PIN	Interrupt message to the host (INTA)	EEPROM	page 42
0x3E–0x3F	RES	Reserved	—	—

Table 7-2. PCI Express Configuration Space Register Summary

Offset	Description	Initialized by	Page
0x40	Power Management Capability	EEPROM	page 43
0x44	Power Management Status/Control	Host	page 44
0x50	Message Capability ID	AR9287	page 44
0x51	Message Capability Next Pointer	AR9287	page 44
0x52	Message Control	EEPROM	page 45
0x54	Message Address	Host	page 46
0x58	Message Data	Host	page 46
0x60	PCI Express Capabilities List	EEPROM	page 46
0x62	PCI Express Capabilities	EEPROM	page 47
0x6C	Link Capabilities	EEPROM	page 47
0x70	Link Control	EEPROM	page 48

7.1.1 Vendor ID (VENDOR_ID)

Offset: 0x00
 Access: Read-Only
 Size: 16 bits

This register contains the vendor identification number. The value of this register is loaded from the EEPROM. If no valid EEPROM present, reading this registers returns the Atheros vendor ID of 0x168C.

Bit	Name	Description
15:0	VENDOR_ID	Vendor identification

7.1.2 Device ID (DEVICE_ID)

Offset: 0x02
 Access: Read-Only
 Size: 16 bits

This register identifies the device type. The default value of this register is loaded from the EEPROM, when the EEPROM is attached, or if the EEPROM content is not valid, a value of 0xFF1B returns when read from the register.

Bit	Name	Description
15:0	DEVICE_ID	Device identification

7.1.3 Command (COMMAND)

Offset: 0x04

Access: Read/Write

Size: 16 bits

Reset Value: Undefined

This register provides access control of the AR9287 PCI Express interface. The register is controlled by the host.

Bit	Name	Description
15:9	RES	Reserved. Must be written with zero. On read, can contain any value.
8	SERR_EN	System error enable
		0 Disable. Default
		1 Enable
7	RES	Reserved. Must be written with zero. On read, can contain any value.
6	PAR_ERR_RESP	Parity error response. Default = 0.
		0 Disable
		1 Enable
5:3	RES	Reserved. Must be written with zero. On read, can contain any value.
2	BUS_MSTR	Bus master
		0 Disable
		1 Enable
1	MEM_SPACE	Memory space
		0 Disable
		1 Enable
0	IO_SPACE	I/O space
		0 Disable
		1 Enable (not used)

7.1.4 Status (STATUS)

Offset: 0x06
 Access: Read/Write, except as noted
 Size: 16 bits
 Reset Value: 0x0290

This register provides status of the functionality provided by the AR9287 PCI Express interface. This register is mostly controlled by the AR9287.

Bit	Name	Description			
15	DETECT_PAR_ERR	Detected parity error			
		<i>On Read:</i>	<i>On Write:</i>		
		0	No error	0	Do not clear error bit
		1	Error	1	Clear error bit
14	SIG_SYS_ERR	Signaled system error			
		<i>On Read:</i>	<i>On Write:</i>		
		0	No error	0	Do not clear error bit
		1	Error	1	Clear error bit
13	RX_MAS_ABORT	Received master abort			
		<i>On Read:</i>	<i>On Write:</i>		
		0	No abort	0	Do not clear abort bit
		1	Abort	1	Clear abort bit
12	RX_TARG_ABORT	Received target abort			
		<i>On Read:</i>	<i>On Write:</i>		
		0	No abort	0	Do not clear abort bit
		1	Abort	1	Clear abort bit
11	SIG_TARG_ABORT	Signaled target abort			
		<i>On Read:</i>	<i>On Write:</i>		
		0	No abort	0	Do not clear abort bit
		1	Abort	1	Clear abort bit
10:9	RES	Reserved			
8	MD_PAR_ERR	Master data parity error			
		<i>On Read:</i>	<i>On Write:</i>		
		0	No error	0	Do not clear error bit
		1	Error	1	Clear error bit
7:5	RES	Reserved. Must be written with zero. On read, can contain any value.			
4	CAP_LIST	Capabilities list. Read only. Hard-wired to 1.			
3	INT	Interrupt Status. Read Only. Indicates outstanding interrupt request for that function. Note that this bit only associated with INTx messages, and has no meaning if the device is using Message Signaled Interrupts.			
2:0	RES	Reserved. Must be written with zero. On read, can contain any value.			

7.1.5 Revision ID (REVISION_ID)

Offset: 0x08
 Access: Read/Write
 Size: 8 bits

This register contains the device revision ID. Value can be loaded from the EEPROM.

Bit	Name	Description
7:0	REVISION_ID	Revision identification; Default (without EEPROM) = 01

7.1.6 Class Code (CLASS_CODE)

Offset: 0x09
Access: Read-Only
Size: 24 bits

This register contains the class code ID that identifies the basic function of the device. Value is loaded from the EEPROM.

Bit	Name	Description
23:0	CLASS_CODE	Class code identification value; Default = 0x020000

7.1.7 Cache Line Size (CACHE_SZ)

Offset: 0x0C
Access: Read/Write
Size: 8 bits
Reset Value: 0x00

This host-controlled register contains the size of the system cache line.

Bit	Name	Description
7:0	CACHE_SZ	Cache line size, in units of 32-bit words (4 bytes); Default = 0

7.1.8 Latency Timer (LATENCY_TMR)

Offset: 0x0D
Access: Read/Write
Size: 8 bits
Reset Value: 0x00

This register does not apply to PCI Express.

Bit	Name	Description
7:0	LATENCY_TMR	Latency timer; hardwired to 0

7.1.9 Header Type (HDR_TYPE)

Offset: 0x0E
Access: Read-Only
Size: 8 bits

Contains the header type information. Value can be loaded from the EEPROM.

Bit	Name	Description
7:0	HDR_TYPE	Header type; Nonbridge PCIE device; Default = 0

7.1.10 Base Address (BASE_ADDR)

Offset: 0x10
Access: Bits [15:0] are Read Only (always return 0)
Bits [31:16] are Read/Write
Size: 32 bits
Reset Value: Undefined

This register contains the base address for accessing the AR9287 WLAN memory mapped registers. This register is controlled by the host.

Bit	Name	Description
31:0	BASE_ADDR	Base address

7.1.11 Subsystem Vendor ID (SSYS_VEND_ID)

Offset: 0x2C
Access: Read-Only
Size: 16 bits

This register contains the subsystem vendor identification number. Value can be loaded from the EEPROM.

Bit	Name	Description
15:0	SSYS_VEND_ID	Subsystem vendor ID; Default = 0

7.1.12 Subsystem ID (SSYS_ID)

Offset: 0x2E
Access: Read-Only
Size: 16 bits

This register contains the subsystem device identification number. Value can be loaded from the EEPROM.

Bit	Name	Description
15:0	SSYS_ID	Subsystem ID; Default = 0

7.1.13 Capabilities Pointer (CAP_PTR)

Offset: 0x34
Access: Read-Only
Size: 8 bits
Reset Value: 0x40

This register contains the value of the capabilities pointer. Default value is provided by the AR9287.

Bit	Name	Description
7:0	CAP_PTR	Capabilities pointer value; Default = 40

7.1.14 Interrupt Line (INT_LINE)

Offset: 0x3C
Access: Read/Write
Size: 8 bits
Reset Value: 0x00

This host-controlled register contains the host interrupt controller's interrupt line value that the device's interrupt pin is connected to.

Bit	Name	Description
7:0	INT_LINE	Interrupt line value; Default = 0

7.1.15 Interrupt Pin (INT_PIN)

Offset: 0x3D
Access: Read-Only
Size: 8 bits

This register defines which of the four PCIE interrupt request pins, a PCIE function is connected to. Value can be loaded from the EEPROM.

Bit	Name	Description
7:0	INT_PIN	Interrupt pin value; Default = 1 (INTA)

7.1.16 Power Management Capability

Offset: 0x40

Access: Read-Only

Size: 32 bits

Reset Value: 0x0102 5001

The power management capability structure is required for all PCI Express devices to support D0 and D3 device states to indicate PME message passing capability. This register is loaded by EEPROM only.

Bit	Name	Description																		
31:27	PME Support	Indicates the power states in which the device can generate a PME; Default = 0																		
26	D2 Support	Always 0																		
25	D1 Support	Always 0																		
24:22	AUX Current	Reports the 3.3 V _{aux} current requirements for the function. It is encoded as: <table border="1" data-bbox="602 646 1438 1031"> <thead> <tr> <th>Bit Value</th> <th>Max Current Required</th> </tr> </thead> <tbody> <tr> <td>111</td> <td>375 mA</td> </tr> <tr> <td>110</td> <td>320 mA</td> </tr> <tr> <td>101</td> <td>270 mA</td> </tr> <tr> <td>100</td> <td>220 mA (Default)</td> </tr> <tr> <td>011</td> <td>160 mA</td> </tr> <tr> <td>010</td> <td>100 mA</td> </tr> <tr> <td>001</td> <td>55 mA</td> </tr> <tr> <td>000</td> <td>0 mA</td> </tr> </tbody> </table>	Bit Value	Max Current Required	111	375 mA	110	320 mA	101	270 mA	100	220 mA (Default)	011	160 mA	010	100 mA	001	55 mA	000	0 mA
Bit Value	Max Current Required																			
111	375 mA																			
110	320 mA																			
101	270 mA																			
100	220 mA (Default)																			
011	160 mA																			
010	100 mA																			
001	55 mA																			
000	0 mA																			
21	DSI	Device-specific initialization. Default = 0.																		
20:19	RES	Reserved																		
18:16	Version	Set to 0x2																		
15:8	Next Capability Pointer	Offset to the next PCIE capability structure																		
7:0	Capability ID	Must be set to 0x1																		

7.1.17 Power Management Status/Control

Offset: 0x44

Access: Read/Write except for bits 31:22; bits 14:13, which are read only

Size: 32 bits

Reset Value: 0x0000 0000

The power management capability structure is required for all PCI Express devices to support D0 and D3 device states to indicate PME message passing capability.

Bit	Name	Description
31:24	Data	Always 0
23:16	PME Status	Devices that consume AUX power must preserve the value of this register when AUX power is available in such devices, this register value is not modified by hot, warm, or cold reset.
15:13	Data Scale	Always 0
12:8	PME Enable	Devices that consume AUX power must preserve the value of this register when AUX power is available in such devices, this register value is not modified by hot, warm, or cold reset.
1:0	Power State	00 D0 (Default)
		01 D1
		10 D2
		11 D3

7.1.18 Message Capability ID (CAP_ID)

Offset: 0x50

Access: Read-Only

Size: 8 bits

Reset Value: 0x05

Enumerates the PCI Express capability structure in the PCIE configuration space capability list.

Bit	Name	Description
7:0	CAP_ID	Capability ID. Indicates the PCI Express capability structure. This field must return a capability ID of 0x10 indicating that this is a PCI Express capability structure.

7.1.19 Message Capability Next Pointer (NXT_PTR)

Offset: 0x51

Access: Read-Only

Size: 8 bits

Reset Value: 0x60

This register contains the message capability next pointer. The value can be loaded from the EEPROM.

Bit	Name	Description
7:0	NXT_PTR	Next capability pointer. Indicates the offset to the next PCIE capability structure or 0x00 if no other items exist in the linked list of capabilities.

7.1.20 Message Control

Offset: 0x52
 Access: Read/Write
 Size: 16 bits
 Reset Value: 0x0000

Provides system control over MSI. A device driver is not permitted to modify the register's read/write bits and fields.

Bit	Name	Description	
15:8	RES	Reserved	
7	64-bit Address Capable	(Read-only bit)	
		0	The function is not capable of generating a 64-bit message address
		1	The function is capable of generating a 64-bit message address
6:4	Multiple Message Enable	System software writes to this field indicate the number of allocated messages (equal to or less than the number of requested messages). After reset, the field's state is 000. When MSI is enabled, a device is allocated at least one message, defined as:	
		Encoding	Number of Allocated Messages
		000	1
		001	2
		010	4
		011	8
		100	16
		101	32
		110	Reserved
		111	Reserved
3:1	Multiple Message Capable	(Read-only bit) System software reads this field to determine the number of requested messages, defined as:	
		Encoding	Number of Allocated Messages
		000	1
		001	2
		010	4
		011	8
		100	16
		101	32
		110	Reserved
		111	Reserved
0	MSI Enable	0	The function is prohibited from using MSI to request service. The bit's state after reset is 0. After reset, MSI is disabled (bit 0 is cleared). System software can enable MSI by setting bit 0 and can modify the register's read/write bit fields.
		1	The function is permitted to use MSI to request service. System configuration software sets this bit to enable MSI. A device driver is prohibited to from writing this bit to mask a function's service request.

7.1.21 Message Address

Offset: 0x54
Access: Read/Write
Size: 32 bits
Reset Value: 0x00000000

Bit	Name	Description
31:2	Message Address	System-specified message address. If the message enable bit (bit 0 of the “ Message Control ” register) is set, the contents specify the DWORD aligned address for the MSI memory write transaction.
1:0	RES	Reserved. Always returns to 0 on read.

7.1.22 Message Data

Offset: 0x58
Access: Read/Write
Size: 16 bits
Reset Value: 0x0000

Bit	Name	Description
15:0	Message Data	System-specified message. Each MSI function is allocated up to 32 unique messages. System architecture specifies the number of unique messages supported by the system. If the message enable bit (bit 0 of the “ Message Control ” register) is set, the message data is driven onto the lower word of the memory write transaction’s data phase.

7.1.23 PCI Express Capabilities List

Offset: 0x60
Access: Read-Only
Size: 16 bits
Reset Value: 0x9010

This register enumerates the PCI Express capability structure in the PCIE configuration space capability list. Default is loaded from the EEPROM.

Bit	Name	Description
15:8	Next Capability Pointer	Indicates the offset to the next PCIE capability structure or 0x00 if no other items exist in the linked list of capabilities.
7:0	Capability ID	Indicates the PCI Express Capability structure. This field must return a Capability ID of 0x10 indicating that this is a PCI Express Capability structure. Ready only

7.1.24 PCI Express Capabilities

Offset: 0x62

Access: Read-Only. Changeable by the EEPROM (except for bit 8)

Size: 16 bits

Reset Value: 0x0011

This register contains the PCI Express capability values. Default is loaded from the EEPROM.

Bit	Name	Description
15:14	RES	Reserved
13:9	Interrupt Message Number	Required when the function is allocated more than one MSI interrupt number to contain the offset between the base message data and the MSI message generated when any status bit in either the slot status register or root port status register of the capability structure is set. Hardware must update this field so that it is correct if the MSI messages assigned to the device changes.
8	Slot Implemented	Indicates that the PCI Express link associated with this port connected to a slot. Hardwired to 0.
7:4	Device Port Type	Indicates the PCI Express logical device 0000 PCI Express endpoint device All other encodings are reserved.
3:0	Capability Version	Indicates the PCI Express capability structure version number

7.1.25 Link Capabilities

Offset: 0x6C

Access: Read-Only

Size: 32 bits

Reset Value: 0x0003_3C11

This register identifies the PCIE link specific capabilities.

Bit	Name	Description
31:24	Port Number	Indicates the PCIE port number for the given PCIE Link.
23:18	RES	Reserved
17:15	L1 Exit Latency	Indicates the L1 exit latency for the given PCIE Link. The value reported indicates the length of time this Port requires to complete transition from L1 to L0. 011 4 μ s to less than 8 μ s
14:12	L0s Exit Latency	Indicates the L0s exit latency for the given PCIE Link. The value reported indicates the length of time this port requires to complete transition from L0s to L0. 011 256 ns to less than 512 ns
11:10	Active State Power Management (ASPM) Support	Indicates the level of ASPM supported on the given PCIE link. 11 L0s and L1 Supported
9:4	Maximum Link Width	Indicates the maximum link width. 000001 x1
3:0	Maximum Link Speed	Indicates the maximum link speed of the given PCIE link. 0001 2.5 Gbps link

7.1.26 Link Control

Offset: 0x70
Access: Read/Write
Size: 16 bits

This register controls PCIE link-specific parameters.

Bit	Name	Description								
15:9	RES	Reserved								
8	RES	Reserved; hardwired to 0								
7	Extended Synch	When set, forces the transmission of additional ordered sets when exiting the L0s state and when in the recovery state. This mode provides external devices (e.g., logic analyzers) monitoring the link time to achieve bit and symbol lock before the Link enters the L0 state and resumes communication. Default is 0.								
6	Common Clock Configuration	When set, indicates that this component and the component at the opposite end of this link are operating with a distributed common reference clock. A setting of 0 indicates that this component and the component at the opposite end of this Link are operating with asynchronous reference clock. Default is 0.								
5:2	RES	Reserved								
1:0	Active State Power Management (ASPM) Control	<p>Controls the level of ASPM supported on the given PCIE link.</p> <p>NOTE: L0s Entry Enabled indicates the Transmitter entering L0s is supported. The Receiver must be capable of entering L0s even when the field is disabled (00).</p> <p>ASPM L1 must be enabled by software in the upstream component on a link prior to enabling ASPM L1 in the downstream component on that link. When disabling ASPM L1, software must disable ASPM L1 in the downstream component on a link prior to disabling ASPM L1 in the upstream component on that link. ASPM L1 must only be enabled on the downstream component if both components on a link support ASPM L1.</p> <p>Defined encodings are:</p> <table border="1"> <tbody> <tr> <td>00</td> <td>Disabled; Default value of this field is 00 unless otherwise required by a particular form factor</td> </tr> <tr> <td>01</td> <td>L0s entry enabled</td> </tr> <tr> <td>10</td> <td>L1 entry enabled</td> </tr> <tr> <td>11</td> <td>L0s and L1 entry enabled</td> </tr> </tbody> </table>	00	Disabled; Default value of this field is 00 unless otherwise required by a particular form factor	01	L0s entry enabled	10	L1 entry enabled	11	L0s and L1 entry enabled
00	Disabled; Default value of this field is 00 unless otherwise required by a particular form factor									
01	L0s entry enabled									
10	L1 entry enabled									
11	L0s and L1 entry enabled									

7.2 AR9287 Internal Register Descriptions

This section describes the AR9287 internal registers.

Offset	Type	Page
0x0000–0x00FC	General DMA and Rx-Related (MAC Interface)	page 49
0x0800–0x0A40	QCU	page 70
0x1000–0x12F0	DCU	page 76
0x1F00–0x1FFC	MAC Interface	page 86
0x2000–0x3FFC	EEPROM Interface	page 87
0x4000–0x409C	Host Interface	page 87
0x7000–0x7FFC	RTC Interface	page 99
0x8000–0x97FC	MAC PCU	page 103
0x825C–0x8294 0xE000–0xEFFC	Wake-on-Wireless (WoW)	page 129

7.2.1 General DMA and Rx-Related Registers

Table 7-3 shows the mapping of the general DMA and Rx-related (MAC interface) registers.

Table 7-3. General DMA and Rx-Related Registers

Offset	Name	Description	Page
0x0008	CR	Command	page 50
0x000C	RXDP	Receive Queue Descriptor Pointer	page 50
0x0014	CFG	Configuration and Status	page 51
0x0020	MIRT	Maximum Interrupt Rate Threshold	page 52
0x0024	IER	Interrupt Global Enable	page 52
0x0028	TIMT	Transmit Interrupt Mitigation Thresholds	page 52
0x002C	RIMT	Receive Interrupt Mitigation Thresholds	page 53
0x0030	TXCFG	Transmit Configuration	page 53
0x0034	RXCFG	Receive Configuration	page 54
0x0040	MIBC	MIB Control	page 54
0x0044	TOPS	Timeout Prescale	page 54
0x0048	RXNF	Rx No Frame	page 55
0x004C	TXNF	Tx No Frame	page 55
0x0050	RFGTO	Receive Frame Gap Timeout	page 55
0x0054	RFCNT	Receive Frame Count Limit	page 55
0x0064	GTT	Global Transmit Timeout	page 56
0x0068	GTTM	Global Transmit Timeout Mode	page 56
0x006C	CST	Carrier Sense Timeout	page 56
0x0080	ISR_P	Primary Interrupt Status	page 57
0x0084	ISR_S0	Secondary Interrupt Status 0	page 59
0x0088	ISR_S1	Secondary Interrupt Status 1	page 59
0x008C	ISR_S2	Secondary Interrupt Status 2	page 60
0x0090	ISR_S3	Secondary Interrupt Status 3	page 60
0x0094	ISR_S4	Secondary Interrupt Status 4	page 61
0x0098	ISR_S5	Secondary Interrupt Status 5	page 61
0x00A0	IMR_P	Primary Interrupt Mask	page 62
0x00A4	IMR_S0	Secondary Interrupt Mask 0	page 63
0x00A8	IMR_S1	Secondary Interrupt Mask 1	page 63
0x00AC	IMR_S2	Secondary Interrupt Mask 2	page 64
0x00B0	IMR_S3	Secondary Interrupt Mask 3	page 64
0x00B4	IMR_S4	Secondary Interrupt Mask 4	page 65
0x00B8	IMR_S5	Secondary Interrupt Mask 5	page 65

Table 7-3. General DMA and Rx-Related Registers (continued)

Offset	Name	Description	Page
0x00C0	ISR_P_RAC	Primary Interrupt Status Read-and-Clear	page 66
0x00C4	ISR_S0_S	Secondary Interrupt Status 0 (Shadow Copy)	page 66
0x00C8	ISR_S1_S	Secondary Interrupt Status 1 (Shadow Copy)	page 66
0x00CC	ISR_S2_S	Secondary Interrupt Status 2 (Shadow Copy)	page 66
0x00D0	ISR_S3_S	Secondary Interrupt Status 3 (Shadow Copy)	page 67
0x00D4	ISR_S4_S	Secondary Interrupt Status 4 (Shadow Copy)	page 67
0x00D8	ISR_S5_S	Secondary Interrupt Status 5 (Shadow Copy)	page 67

7.2.1.1 Command (CR)

Offset: 0x0008

Access: Read/Write

Cold Reset: 0x0

Warm Reset: (Same as Cold Reset)

Bit	Name	Description
31:7	RES	Reserved
6	SWI	Software interrupt; this bit is one-shot/auto-cleared, so it always reads as 0
5	RXD	Rx disable
4:3	RES	Reserved
2	RXE	Receive (Rx) enable
1:0	RES	Reserved

7.2.1.2 Rx Queue Descriptor Pointer (RXDP)

Offset: 0x000C

Access: Read/Write

Cold Reset: (Undefined)

Warm Reset: (Unaffected)

Bit	Name	Description
31:2	RXDP	Rx descriptor pointer
1:0	RES	Reserved

7.2.1.3 Configuration and Status (CFG)

Offset: 0x0014

Access: Read/Write

Cold Reset: See field description

Warm Reset: (Same as Cold Reset)

Bit	Name	Reset	Description	
31:19	RES	0x0	Reserved	
18:17	FULL_THRESHOLD	0x0	PCIE core master request queue full threshold	
			0	Use default value of 4
			3:1	Use indicated value
16:13	RES	0x0	Reserved	
12	CFG_HALT_ACK	0x0	DMA halt status	
			0	DMA has not yet halted
			1	DMA has halted
11	CFG_HALT_REQ	0x0	DMA halt in preparation for reset request	
			0	DMA logic operates normally
			1	Request DMA logic to stop so software can reset the MAC Bit [12] of this register indicates when the halt has taken effect; the DMA halt IS NOT recoverable; once software sets bit [11] to request a DMA halt, software must wait for bit [12] to be set and reset the MAC.
10	CFG_CLKGATE_DIS	0x0	Clock gating disable	
			0	Allow clock gating in all DMA blocks to operate normally
			1	Disable clock gating in all DMA blocks (for debug use)
9	RES	0x0	Reserved	
8	RES	0x1	Reserved	
7:6	RES	0x0	Reserved	
5	REG_CFG_ADHOC	0x0	AP/ad hoc indication	
			0	AP mode MAC is operating either as an access point (AP) or as a station (STA) in a BSS
			1	Ad hoc mode MAC is operating as a STA in an independent basic service set (IBSS)
4	MODE_MMR	0x0	Byteswap register access (MMR) data words	
3	MODE_RCV_DATA	0x0	Byteswap Rx data buffer words	
2	MODE_RCV_DESC	0x0	Byteswap Rx descriptor words	
1	MODE_XMIT_DATA	0x0	Byteswap Tx data buffer words	
0	MODE_XMIT_DESC	0x0	Byteswap Tx descriptor words	

7.2.1.4 Maximum Interrupt Rate Threshold (MIRT)

Offset: 0x0020

Access: Read/Write

Cold Reset: 0x0

Warm Reset: (Same as Cold Reset)

Bit	Name	Description
31:16	RES	Reserved
15:0	INTR_RATE_THRESH	Maximum interrupt rate threshold This register is described in μ s up to a maximum of 65.535 ms. If this register is 0x0, the interrupt mitigation mechanism is disabled. The maximum interrupt rate timer is started when either the TXINTM or RXINTM status bits are set. TXMINTR or RXMINTR are asserted at this time. No future TXINTM or RXINTM events can cause the TXMINTR or RXMINTR to be asserted until this timer has expired. If both the TXINTM and RXINTM status bits are set while the timer is expired then the TXMINTR and RXMINTR will round robin between the two.

7.2.1.5 Interrupt Global Enable (IER)

Offset: 0x0024

Access: Read/Write

Cold Reset: 0x0

Warm Reset: (Same as Cold Reset)

Bit	Name	Description
31:1	RES	Reserved
0	REG_IER	Enable hardware signalling of interrupts

7.2.1.6 Tx Interrupt Mitigation Thresholds (TIMT)

Offset: 0x0028

Access: Read/Write

Cold Reset: 0x0

Warm Reset: (Same as Cold Reset)

Bit	Name	Description
31:16	TX_FIRST_PKT_THRESH	Tx first packet threshold This register is in μ s up to a maximum of 65.535 ms. If this register is 0x0, the interrupt mitigation mechanism is disabled. The Tx first packet timer starts counting after any Tx completion. If the timer is still counting when the next Tx completion occurs, it resets and starts over. The first Tx packet timer expires when either the last Tx packet threshold equals the last Tx packet timer count or the first Tx packet threshold equals the first Tx packet timer count.
15:0	TX_LAST_PKT_THRESH	Tx last packet threshold This register is in μ s up to a maximum of 65.535 ms. If this register is 0x0, the interrupt mitigation mechanism is disabled. The Tx last packet timer starts counting after any Tx completion. If the timer is still counting when the next Tx completion occurs, it resets and starts over. The last Tx packet timer expires when either the last Tx packet threshold equals the last Tx packet timer count or the first Tx packet threshold equals the first Tx packet timer count.

7.2.1.7 Rx Interrupt Mitigation Thresholds (RIMT)

Offset: 0x002C

Access: Read/Write

Cold Reset: (See Field Descriptions)

Warm Reset: (Same as Cold Reset)

Bit	Name	Description
31:16	RX_FIRST_PKT_THRESH	Receive first packet threshold This register is in μ s up to a maximum of 65.535 ms. If this register is 0x0, the interrupt mitigation mechanism is disabled. The receive first packet timer starts counting after any receive completion. If the timer is still counting when the next receive completion occurs, it resets and starts over. The first receive packet timer expires when either the last receive packet threshold equals the last receive packet timer count or the first receive packet threshold equals the first receive packet timer count.
15:0	RX_LAST_PKT_THRESH	Receive last packet threshold This register is in μ s up to a maximum of 65.535 ms. If this register is 0x0, the interrupt mitigation mechanism is disabled. The receive last packet timer starts counting after any receive completion. If the timer is still counting when the next receive completion occurs, it resets and starts over. The last receive packet timer expires when either the last receive packet threshold equals the last receive packet timer count or the first receive packet threshold equals the first receive packet timer count.

7.2.1.8 Tx Configuration (TXCFG)

Offset: 0x0030

Access: Read/Write

Cold Reset: (See Field Descriptions)

Warm Reset: (Same as Cold Reset)

Bit	Name	Reset	Description	
31:18	RES	0x0	Reserved	
17	DIS_RETRY_UNDERRUN	0x1	Disable retry of underrun packets	
			0	Underrun packets will retry indefinitely
			1	Underrun packets will quit after first underrun attempt and write status indicating underrun
16:15	RES	0x0	Reserved	
14:10	RES	0x0	Reserved	
9:4	TXCFG_TRIGLVL	0x1	Frame trigger level Specifies the minimum number of bytes, in units of 64 bytes, that must be DMAed into the PCU TXFIFO before the PCU initiates sending the frame on the air. Resets to 0x1 (meaning 64B or a full frame, whichever occurs first).	
3	RES	0x0	Reserved	
2:0	TXCFG_DMA_SIZE	0x5	Maximum DMA request size for master reads	
			0	4 B
			1	8 B
			2	16 B
			3	32 B
			4	64 B
			5	128 B
			6	256 B
			7	Reserved

7.2.1.9 Rx Configuration (RXCFG)

Offset: 0x0034

Access: Read/Write

Cold Reset: (See Field Descriptions)

Warm Reset: (Same as Cold Reset)

Bit	Name	Reset	Description	
31:5	RES	0x0	Reserved	
4:3	ZERO_LEN_DMA_EN	0x0	Zero-length frame DMA enable	
			0	Disable DMA of all zero-length frames. In this mode, the DMA logic suppresses all zero-length frames. Reception of zero-length frames is invisible to the host (they neither appear in host memory nor consume a Rx descriptor).
			1	Reserved
			2	Enable DMA of all zero-length frames. In this mode, all zero-length frames (chirps, double-chirps, and non-chirps) are DMAed into host memory just like normal (non-zero-length) frames.
			3	Reserved
2:0	DMA_SIZE	0x4	Maximum DMA size for master writes (See the encodings for the register “Tx Configuration (TXCFG)” on page 53)	

7.2.1.10 MIB Control (MIBC)

Offset: 0x0040

Access: Read/Write

Cold Reset: (See Field Descriptions)

Warm Reset: (Same as Cold Reset)

Bit	Name	Reset	Description	
31:4	RES	0x0	Reserved	
3	MIBC_MIBS	0x0	MIB counter strobe. This bit is a one-shot and always reads as zero. For writes:	
			0	No effect
			1	Causes every MIB counter to increment by one
2	MIBC_ACLR	0x1	Clear all counters	
1	MIBC_FRZ	0x1	Freeze all counters	
0	MIBC_WRN_COMP	0x0	Warning test indicator. Read Only	

7.2.1.11 Timeout Prescale (TOPS)

Offset: 0x0044

Access: Read/Write

Cold Reset: 0x0000

Warm Reset: (Same as Cold Reset)

Bit	Name	Description
31:16	RES	Reserved
15:0	TOPS	Timeout prescale count

7.2.1.12 Rx No Frame (RXNF)

Offset: 0x0048

Access: Read/Write

Cold Reset: 0x000

Warm Reset: (Same as Cold Reset)

Bit	Name	Description
31:10	RES	Reserved
9:0	RXNPTO	Timeout count limit

7.2.1.13 Tx No Frame (TXNF)

Offset: 0x004C

Access: Read/Write

Cold Reset: 0x000

Warm Reset: (Same as Cold Reset)

Bit	Name	Description
31:20	RES	Reserved
19:10	TXNPMASK	QCU mask Specifies the set of QCUs for which frame completions cause a reset of the TXNOFR timeout.
9:0	TXNPTO	Timeout count limit

7.2.1.14 Rx Frame Gap Timeout (RFGTO)

Offset: 0x0050

Access: Read/Write

Cold Reset: 0x000

Warm Reset: (Same as Cold Reset)

Bit	Name	Description
31:10	RES	Reserved
9:0	RPGTO	Timeout count limit

7.2.1.15 Rx Frame Count Limit (RFCNT)

Offset: 0x0054

Access: Read/Write

Cold Reset: (See Field Descriptions)

Warm Reset: (Same as Cold Reset)

NOTE: Set to 0x1F (decimal 31) to disable.

Bit	Name	Reset	Description
31:5	RES	0x0	Reserved
4:0	RPCNT	0x1F	Frame count limit

7.2.1.16 Global Tx Timeout (GTT)

Offset: 0x0064

Access: Read/Write

Cold Reset: 0x0

Warm Reset: (Same as Cold Reset)

Bit	Name	Description
31:16	GTT_LIMIT	Timeout limit (in TU: 1024 μ s) On reset, this value is set to 25 TU.
15:0	GTT_CNT	Timeout counter (in TU: 1024 μ s) The current value of the timeout counter that is reset on every transmit. If no Tx frame is queued up and ready to transmit, the timeout counter stays at 0 or else the counter increments every 1024 μ s. If the timeout counter is equal to or greater than the timeout limit, the global transmit timeout interrupt is set in the ISR. This mechanism can be used to detect whether a Tx frame is ready and is unable to be transmitted.

7.2.1.17 Global Tx Timeout Mode (GTTM)

Offset: 0x0064

Access: Read/Write

Cold Reset: 0x0

Warm Reset: (Same as Cold Reset)

Bit	Name	Description
31:6	RES	Reserved
5	BT_QCU_FR_DISABLE	Disable QCU_FR_ACTIVE for Bluetooth If this bit is clear, then QCU_FR_ACTIVE is used instead.
4	GTT_QCU_FR_DISABLE	Disable QCU_FR_ACTIVE for GTT If this bit is clear, then QCU_FR_ACTIVE is used instead.
3	CST_USEC_STROBE	CST μ s strobe If this bit is set, then the CST timer will not use the TU based strobe but rather use the μ s strobe to increment the timeout counter.
2	RESET_ON_CHAN_IDLE	Reset count on chan idle low. Reset count every time channel idle is low.
1	IGNORE_CHAN_IDLE	Ignore channel idle If this bit is set then the GTT timer does not increment if the channel idle indicates the air is busy or NAV is still counting down.
0	USEC_STROBE	μ s strobe If this bit is set then the GTT timer will not use the TU based strobe but rather use a μ s strobe to increment the timeout counter.

7.2.1.18 Carrier Sense Timeout (CST)

Offset: 0x006C

Access: Read/Write

Cold Reset: 0x0

Warm Reset: (Same as Cold Reset)

Bit	Name	Description
31:16	CST_LIMIT	Timeout limit (in TU: 1024 μ s). On reset, this value is set to 16 TU.
15:0	CST_CNT	Timeout counter (in TU: 1024 μ s) The current value of the timeout counter that is reset on every transmit. If no Tx frame is queued up and ready to transmit, the timeout counter stays at 0 or the counter increments every 1024 μ s. If the timeout counter is equal to or greater than the timeout limit then carrier sense timeout (CST) interrupt is set in the ISR. This counter starts counting if any queues are ready for Tx. It continues counting when RX_CLEAR is low, which is useful to determine whether the transmit is stuck because RX_CLEAR is low for a long time.

7.2.1.19 Primary Interrupt Status (ISR_P)

Offset: 0x0080

Access: Read/Write-One-to-Clear

Cold Reset: 0x0

Warm Reset: (Same as Cold Reset)

NOTE:

- The bits that are logical ORs of bits in the secondary ISRs are generated by logically ORing the secondary ISR bits after the secondary ISR bits have been masked with the appropriate bits from the corresponding secondary interrupt mask register.
- A write of one to a bit that is a logical OR of bits in a secondary ISR clears the secondary ISR bits from which the primary ISR bit is generated. E.g.: A write of a one to the TXOK bit (bit [6]) in ISR_P clears all 10 TXOK bits in ISR_S0 (bits [9:0] of "Secondary Interrupt Status 0 (ISR_S0)").
- Only the bits in this register (ISR_P) and the primary interrupt mask register ("Primary Interrupt Mask (IMR_P)") control whether the MAC's interrupt output is asserted. The bits in the several secondary interrupt status/mask registers control what bits are set in the primary interrupt status register; however, the IMR_S* registers do not determine whether an interrupt is asserted. That is, an interrupt is asserted only when the logical AND of ISR_P and IMR_P is non-zero. The secondary interrupt mask/status registers affect which bits are set in ISR_P, but do not directly affect whether an interrupt is asserted.

Bit	Name	Description
31	RXINTM	Rx completion interrupt after mitigation; either the first Rx packet or last Rx packet interrupt mitigation count has reached its threshold (see the register "Rx Interrupt Mitigation Thresholds (RIMT)" on page 53)
30	TXINTM	Tx completion interrupt after mitigation; either the first Tx packet or last Tx packet interrupt mitigation count has reached its threshold (see the register "Tx Interrupt Mitigation Thresholds (TIMT)" on page 52)
29	HCFTO	HCF poll timeout
28	GENTMR	Logical or of all GENERIC TIMER bits in the secondary ISR 5 which include the GENERIC_TIMER_TRIGGER[7:0], GENERIC_TIMER_THRESH[7:0], GENERIC_TIMER_OVERFLOW
27	QTRIG	Logical or of all QTRIG bits in secondary ISR 4; indicates that at least one QCU's frame scheduling trigger event has occurred
26	QCBURN	Logical or of all QCBURN bits in secondary ISR 3; indicates that at least one QCU's frame scheduling trigger event occurred when no frames were present on the queue
25	QCBROVF	Logical or of all QCBROVF bits in secondary ISR 3; indicates that at least one QCU's CBR expired counter has reached the value of the QCU's cbr_ovf_thresh parameter
24	RXMINTR	RXMINTR maximum receive interrupt rate; same as RXINTM with the added requirement that maximum interrupt rate count has reached its threshold; this interrupt alternates with TXMINTR.
23	BCNMISC	Miscellaneous beacon-related interrupts This bit is the logical OR of the CST, GTT, TIM, CABEND, DTIMSYNC, BCNTO, CABTO, TSFOOR, DTIM, and TBTT_TIME bits in secondary ISR 2.
22	HCFPOLL	Received directed HCF poll
21	RES	Reserved
20	BNR	Beacon not ready Indicates that the QCU marked as being used for beacons received a DMA beacon alert when the queue contained no frames.

Bit	Name	Description
19	TXMINTR	TXMINTR maximum Tx interrupt rate
18	BMISS	The PCU indicates that it has not received a beacon during the previous N (N is programmable) beacon periods
17	BRSSI	The PCU indicates that the RSSI of a beacon it has received has fallen below a programmable threshold
16	SWBA	The PCU has signalled a software beacon alert
15	RXKCM	Key cache miss; a frame was received with a set key cache miss Rx status bit
14	RXPHY	The PHY signalled an error on a received frame
13	SWI	Software interrupt signalled; see the register “ Command (CR) ” on page 50
12	MIB	One of the MIB regs has reached its threshold
11	TXURN	Logical OR of all TXURN bits in secondary ISR 2. Indicates that the PCU reported a txfifo underrun for at least one QCU’s frame
10	TXEOL	Logical OR of all TXEOL bits in secondary ISR 1; indicates that at least one Tx desc fetch state machine has no more Tx desc’s available
9	TXNOFR	Have not transmitted a frame in TXNOFR timeout clocks. Each QCU has only one TXNOFR bit; see the register “ Tx No Frame (TXNF) ” on page 55
8	TXERR	Logical OR of all TXERR bits in secondary ISR 1; indicates that at least one frame was completed with an error, regardless of whether the InterReq bit was set
7	TXDESC	Logical or of all TXDESC bits in secondary ISR 0; indicates that at least one frame was sent and last desc had the InterReq bit set
6	TXOK	Logical or of all TXOK bits in secondary ISR 0; indicates that at least one frame was completed with no errors and at the requested rate, regardless of whether the InterReq bit was set.
5	RXORN	Rxfifo overrun
4	RXEOL	Rx desc fetch logic has no more Rx desc’s available
3	RXNOFR	No frame was received for RXNOFR timeout clocks
2	RXERR	The frame was received with errors
1	RXDESC	The frame was received and the desc InterReq field was such that an interrupt was generated
0	RXOK	The frame was received with no errors

7.2.1.20 Secondary Interrupt Status 0 (ISR_S0)

Offset: 0x0084

Access: Read/Write-One-to-Clear

Cold Reset: 0x0

Warm Reset: (Same as Cold Reset)

Bit	Description
31:26	Reserved
25	TXDESC for QCU 9
...	...
17	TXDESC for QCU 1
16	TXDESC for QCU 0
15:10	Reserved
9	TXOK for QCU 9
...	...
1	TXOK for QCU 1
0	TXOK for QCU 0

7.2.1.21 Secondary Interrupt Status 1 (ISR_S1)

Offset: 0x0088

Access: Read/Write-One-to-Clear

Cold Reset: 0x0

Warm Reset: (Same as Cold Reset)

Bit	Description
31:26	Reserved
25	TXEOL for QCU 9
...	...
17	TXEOL for QCU 1
16	TXEOL for QCU 0
15:10	Reserved
9	TXERR for QCU 9
...	...
1	TXERR for QCU 1
0	TXERR for QCU 0

7.2.1.22 Secondary Interrupt Status 2 (ISR_S2)

Offset: 0x008C

Access: Read/Write-One-to-Clear

Cold Reset: 0x0

Warm Reset: (Same as Cold Reset)

Bit	Name	Description
31	TBTT_TIME	TBTT-referenced timer interrupt; indicates the PCU's TBTT-referenced timer has elapsed.
30	TSFOOR	TSF out of range; indicates that the corrected TSF received from a beacon differs from the PCU's internal TSF by more than a (programmable) threshold
29	DTIM	A beacon was received with the DTIM bit set and a DTIM count value of zero. Beacons with a set DTIM bit but a non-zero DTIM count do not generate it.
28	CABTO	CAB timeout; a beacon was received that indicated that the STA should expect to receive CAB traffic. However, the PCU's CAB timeout expired either because the station received no CAB traffic, or because the STA received some CAB traffic but never received a CAB frame with the more data bit clear in the frame control field (which would indicate the final CAB frame).
27	BCNTO	Beacon timeout; a TBTT occurred and the STA began waiting to receive a beacon, but no beacon was received before the PCU's beacon timeout expired
26	DTIMSYNC	DTIM synchronization lost; a beacon was received that was expected to be a DTIM but was not, or a beacon was received that was not expected to be a DTIM but was
25	CABEND	End of CAB traffic; a CAB frame was received with the more data bit clear in the frame control field
24	TIM	A beacon was received with the local station's bit set in the TIM element
23	GTT	Global Tx timeout; indicates the GTT count \geq than the GTT limit
22	CST	Carrier sense timeout; indicates the CST count \geq than the CST limit
21:10	Reserved	
9	TXURN for QCU 9	
...	...	
1	TXURN for QCU 1	
0	TXURN for QCU 0	

7.2.1.23 Secondary Interrupt Status 3 (ISR_S3)

Offset: 0x0090

Access: Read/Write-One-to-Clear

Cold Reset: 0x0

Warm Reset: (Same as Cold Reset)

Bit	Description
31:26	Reserved
25	QCBRURN for QCU 9
...	...
17	QCBRURN for QCU 1
16	QCBRURN for QCU 0
15:10	Reserved
9	QCBROVF for QCU 9
1	QCBROVF for QCU 1
...	...
0	QCBROVF for QCU 0

7.2.1.24 Secondary Interrupt Status 4 (ISR_S4)

Offset: 0x0094

Access: Read/Write-One-to-Clear

Cold Reset: 0x0

Warm Reset: (Same as Cold Reset)

Bit	Description
31:10	Reserved
9	QTRIG for QCU 9
...	...
1	QTRIG for QCU 1
0	QTRIG for QCU 0

7.2.1.25 Secondary Interrupt Status 5 (ISR_S5)

Offset: 0x0094

Access: Read/Write-One-to-Clear

Cold Reset: 0x0

Warm Reset: (Same as Cold Reset)

NOTE: The trigger indicates that the TSF matched or exceeded the timer. The threshold is set when the TSF exceeds the timer by the `GENERIC_TIMER_THRESH` value. The `GENERIC_TIMER` overflow occurs when the TSF exceeds the timer by such a large amount that $TSF \geq \text{Timer} + \text{Period}$, indicating incorrect software programming. The `GENERIC_TIMER 0` threshold was removed because timer 0 is special and does not generate threshold event.

Bit	Description
31	GENERIC_TIMER 15 threshold
...	...
17	GENERIC_TIMER 1 threshold
16	GENERIC_TIMER overflow
15	GENERIC_TIMER 15 trigger
...	...
1	GENERIC_TIMER 1 trigger
0	GENERIC_TIMER 0 trigger

7.2.1.26 Primary Interrupt Mask (IMR_P)

Offset: 0x00A0

Access: Read/Write

Cold Reset: 0x0

Warm Reset: (Same as Cold Reset)

NOTE: Only the bits in this register control whether the MAC's interrupt outputs are asserted. The bits in the secondary interrupt mask registers control what bits are set in the "Primary Interrupt Mask (IMR_P)" register; however, the IMR_S* registers do not determine whether an interrupt is asserted.

Bit	Description
31	RXINTM interrupt enable
30	TXINTM interrupt enable
29	HCFTO interrupt enable
28	GENTMR interrupt enable
27	QTRIG interrupt enable
26	QCBRURN interrupt enable
25	QCBROVF interrupt enable
24	RXMINTR interrupt enable
23	BCNMISC interrupt enable
22	HCFPOLL interrupt enable
21	Reserved
20	BNR interrupt enable
19	TXMINTR interrupt enable
18	BMISS interrupt enable
17	BRSSI interrupt enable
16	SWBA interrupt enable
15	RXKCM interrupt enable
14	RXPHY interrupt enable
13	SWI interrupt enable
12	MIB interrupt enable
11	TXURN interrupt enable
10	TXEOL interrupt enable
9	TXNOFR interrupt enable
8	TXERR interrupt enable
7	TXDESC interrupt enable
6	TXOK interrupt enable
5	RXORN interrupt enable
4	RXEOL interrupt enable
3	RXNOFR interrupt enable
2	RXERR interrupt enable
1	RXDESC interrupt enable
0	RXOK interrupt enable

7.2.1.27 Secondary Interrupt Mask 0 (IMR_S0)

Offset: 0x00A4

Access: Read/Write

Cold Reset: 0x0

Warm Reset: (Same as Cold Reset)

Bit	Description
31:26	Reserved
25	TXDESC for QCU 9 interrupt enable
...	...
17	TXDESC for QCU 1 interrupt enable
16	TXDESC for QCU 0 interrupt enable
15:10	Reserved
9	TXOK for QCU 9 interrupt enable
...	...
1	TXOK for QCU 1 interrupt enable
0	TXOK for QCU 0 interrupt enable

7.2.1.28 Secondary Interrupt Mask 1 (IMR_S1)

Offset: 0x00A8

Access: Read/Write

Cold Reset: 0x0

Warm Reset: (Same as Cold Reset)

Bit	Description
31:26	Reserved
25	TXEOL for QCU 9 interrupt enable
...	...
17	TXEOL for QCU 1 interrupt enable
16	TXEOL for QCU 0 interrupt enable
15:10	Reserved
9	TXERR for QCU 9 interrupt enable
...	...
1	TXERR for QCU 1 interrupt enable
0	TXERR for QCU 0 interrupt enable

7.2.1.29 Secondary Interrupt Mask 2 (IMR_S2)

Offset: 0x00AC

Access: Read/Write

Cold Reset: 0x0

Warm Reset: (Same as Cold Reset)

Bit	Name	Description
31	TBTT_TIME	interrupt enable
30	TSFOOR	interrupt enable
29	DTIM	interrupt enable
28	CABTO	interrupt enable
27	BCNTO	interrupt enable
26	DTIMSYNC	interrupt enable
25	CABEND	interrupt enable
24	TIM	interrupt enable
23	GTT	interrupt enable
22	CST	interrupt enable
21:19	Reserved	
18	DPERR	interrupt enable
17	SSERR	interrupt enable
16	MACBT	interrupt enable
15:10	Reserved	
9	TXURN for QCU 9	interrupt enable
...	...	
1	TXURN for QCU 1	interrupt enable
0	TXURN for QCU 0	interrupt enable

7.2.1.30 Secondary Interrupt Mask 3 (IMR_S3)

Offset: 0x00B0

Access: Read/Write

Cold Reset: 0x0

Warm Reset: (Same as Cold Reset)

Bit	Description	
31:26	Reserved	
25	QCBRURN for QCU 9	interrupt enable
...	...	
17	QCBRURN for QCU 1	interrupt enable
16	QCBRURN for QCU 0	interrupt enable
15:10	Reserved	
9	QCBROVF for QCU 9	interrupt enable
...	...	
1	QCBROVF for QCU 1	interrupt enable
0	QCBROVF for QCU 0	interrupt enable

7.2.1.31 Secondary Interrupt Mask 4 (IMR_S4)

Offset: 0x00B4

Access: Read/Write

Cold Reset: 0x0

Warm Reset: (Same as Cold Reset)

Bit	Description
31:10	Reserved
9	QTRIG for QCU 9 interrupt enable
...	...
1	QTRIG for QCU 1 interrupt enable
0	QTRIG for QCU 0 interrupt enable

7.2.1.32 Secondary Interrupt Mask 5 (IMR_S5)

Offset: 0x0094

Access: Read/Write-One-to-Clear

Cold Reset: 0x0

Warm Reset: (Same as Cold Reset)

NOTE: The trigger indicates the TSF matched or exceeded the timer; threshold is set when the TSF exceeds the timer by the GENERIC_TIMER_THRESH value. The GENERIC_TIMER overflow occurs when the TSF exceeds the timer by such a large amount that $TSF \geq \text{Timer} + \text{Period}$, indicating incorrect software programming. The threshold GENERIC_TIMER 0 was removed because timer 0 is special and does not generate a threshold event.

Bit	Description
31	GENERIC_TIMER_THRESHOLD 15
30	GENERIC_TIMER_THRESHOLD 14
...	...
18	GENERIC_TIMER_THRESHOLD 2
17	GENERIC_TIMER_THRESHOLD 1
16	GENERIC_TIMER overflow enable
15	GENERIC_TIMER 15 trigger enable
...	...
1	GENERIC_TIMER 1 trigger enable
0	GENERIC_TIMER 0 trigger enable

7.2.1.33 Primary Interrupt Status Read and Clear (ISR_P_RAC)

Offset: 0x00C0

Access: Read-and-Clear (No Write Access)

Cold Reset: 0x0

Warm Reset: (Same as Cold Reset)

NOTE: A read from this location atomically:

- Copies all secondary ISRs into the corresponding secondary ISR shadow registers (ISR_S0 is copied to ISR_S0_S, etc.)
- Clears all bits of the primary ISR (ISR_P) and all bits of all secondary ISRs (ISR_S0–ISR_S4)
- Returns the contents of the primary ISR (ISR_P)

Bit	Name	Description
31:0	ISR_P	Same format as “Primary Interrupt Status (ISR_P)”

7.2.1.34 Secondary Interrupt Status 0 (ISR_S0_S)

Offset: 0x00C4

Access: Read-Only

Cold Reset: 0x0

Warm Reset: (Same as Cold Reset)

Bit	Name	Description
31:0	ISR_S0	Same format as “Secondary Interrupt Status 0 (ISR_S0)”

7.2.1.35 Secondary Interrupt Status 1 (ISR_S1_S)

Offset: 0x00C8

Access: Read-Only

Cold Reset: 0x0

Warm Reset: (Same as Cold Reset)

Bit	Name	Description
31:0	ISR_S0	Same format as “Secondary Interrupt Status 1 (ISR_S1)”

7.2.1.36 Secondary Interrupt Status 2 (ISR_S2_S)

Offset: 0x00CC

Access: Read-Only

Cold Reset: 0x0

Warm Reset: (Same as Cold Reset)

Bit	Name	Description
31:0	ISR_S0	Same format as “Secondary Interrupt Status 2 (ISR_S2)”

7.2.1.37 Secondary Interrupt Status 3 (ISR_S3_S)

Offset: 0x00D0

Access: Read-Only

Cold Reset: 0x0

Warm Reset: (Same as Cold Reset)

Bit	Name	Description
31:0	ISR_S0	Same format as “Secondary Interrupt Status 3 (ISR_S3)”

7.2.1.38 Secondary Interrupt Status 4 (ISR_S4_S)

Offset: 0x00D4

Access: Read-Only

Cold Reset: 0x0

Warm Reset: (Same as Cold Reset)

Bit	Name	Description
31:0	ISR_S0	Same format as “Secondary Interrupt Status 4 (ISR_S4)”

7.2.1.39 Secondary Interrupt Status 5 (ISR_S5_S)

Offset: 0x00D4

Access: Read-Only

Cold Reset: 0x0

Warm Reset: (Same as Cold Reset)

Bit	Name	Description
31:0	ISR_S0	Same format as “Secondary Interrupt Status 5 (ISR_S5)”

7.2.2 Beacon Handling

Table 7-4. AP in a BSS: Sending Beacon and CAB

QCU	Description	
QCU 9	QCU 9 is used only for beacons QCU 9 feeds into DCU 9, and is the only QCU to feed into DCU 9	
	For QCU 9 <ol style="list-style-type: none"> Set FSP to DBA-gated (see bits [3:0] of “Misc. QCU Settings (Q_MISC)”). Set the bit so the QCU sends beacons (Q_MISC bit [7]). Set the bit to disable CBRExpired counter increment if the local queue has no frames (Q_MISC bit [5]). 	For DCU 9 <ol style="list-style-type: none"> Set the bit so DCU sends beacons (bit [16] of “Misc. DCU-Specific Settings (D_MISC)”). Set the bit to enable global lockout (set D_MISC bits [18:17] to 0x2). Set both CW_MIN and CW_MAX to zero (see “DCU-Specific IFS Settings (D_LCL_IFS)”).
QCU 8	QCU 8 is used only for CAB (for a BSS, CAB is BCAST and MCAST frames) QCU 8 feeds into DCU 8, and is the only QCU to feed into DCU 8	
	For QCU 8 <ol style="list-style-type: none"> Set FSP to DBA-gate Set the ReadyTimeEn bit and set the ReadyTimeDuration (RTD) to: <ul style="list-style-type: none"> ■ $RTD = BeaconInterval - (SBA - DBA)$ ■ <i>BeaconInterval</i> is the interval between TBTTs ■ <i>SBA</i> is the amount of time before TBTT that SBA is generated ■ <i>DBA</i> is the amount of time before TBTT that DBA is generated Set the bit to disable the CBRExpired counter increment if the beacon queue has no frames (bit [6] of “Misc. QCU Settings (Q_MISC)”). Set the bit to disable the CBRExpired counter increment if the local queue has no frames (Q_MISC bit [5]). 	For DCU 8 <ol style="list-style-type: none"> Set the bit to enable global lockout. Software tasks at SBA (all of these must occur before DBA): <ul style="list-style-type: none"> ■ Build beacon and pass it to QCU 9. ■ Build CAB and pass it to QCU 8. ■ Clear all Tx filter bits for DCUs 9 and 8.

Table 7-5. STA in an IBSS: Sending Beacon and CAB

QCU	Description	
QCU 9	QCU 9 is used only for beacons QCU 9 feeds into DCU 9, and is the only QCU to feed into DCU 9	
	For QCU 9	For DCU 9
	<ol style="list-style-type: none"> Set FSP to DBA-gated (Q_MISC bits [3:0]). Set the bit so the QCU sends beacons (Q_MISC bit [7]). 	<ol style="list-style-type: none"> Set DCU to send beacons (D_MISC bit [16]). Set the bit to enable global lockout (set D_MISC bits [18:17] to 0x2). Set both CW_MIN and CW_MAX to twice the usual CW_MIN value (refer to the 802.11 specifications).
QCU 8	QCU 8 is used only for CAB (for an IBSS, CAB is ATIMs followed by data frames requiring preceding ATIM reception) QCU 8 feeds into DCU 8, and is the only QCU to feed into DCU 8	
	For QCU 8	For DCU 8
	<ol style="list-style-type: none"> Set FSP to DBA-gate Set the ReadyTimeEn bit and set the ReadyTimeDuration (RTD) to: $RTD = BeaconInterval - (SBA - DBA)$ Set the bit to disable the CBRExpired counter increment if the beacon queue has no frames (bit [6] of "Misc. QCU Settings (Q_MISC)"). Set the bit to disable the CBRExpired counter increment if the beacon queue has no frames (Q_MISC bit [6]). Set the bit to disable the CBRExpired counter increment if the local queue has no frames (Q_MISC bit [5]). Set the bit to clear TXE if ReadyTime expires (Q_MISC bit [9]). 	<ol style="list-style-type: none"> Set the bit to enable global lockout. Software tasks at SBA (all of these must occur before DBA): <ul style="list-style-type: none"> ■ Build beacon and pass it to QCU 9. ■ Build CAB and pass it to QCU 8. ■ Clear all Tx filter bits for DCUs 9 and 8.

7.2.3 QCU Registers

The QCU registers occupy the offset range 0x0800–0x0A40 in the AR9287 address space. The AR9287 has ten QCUs, numbered from 0 to 9.

Table 7-6. QCU Registers

Offset	Name	Description	Page
0x0800 + (Q << 2) ^[1]	Q_TXDP	Transmit Queue Descriptor Pointer	page 70
0x0840	Q_TXE	Transmit Queue Enable	page 70
0x0880	Q_TXD	Transmit Queue Disable	page 71
0x08C0 + (Q << 2) ^[1]	Q_CBRCFG	CBR Configuration	page 71
0x0900 + (Q << 2) ^[1]	Q_RDYTIMECFG	ReadyTime Configuration	page 71
0x0940	Q_ONESHOTARM_SC	OneShotArm Set Control	page 72
0x0980	Q_ONESHOTARM_CC	OneShotArm Clear Control	page 72
0x09C0 + (Q << 2) ^[1]	Q_MISC	Miscellaneous QCU Settings	page 73
0x0A00 + (Q << 2) ^[1]	Q_STS	Miscellaneous QCU Status	page 75
0x0A40	Q_RDYTIMESHDN	ReadyTimeShutdown Status	page 75

[1]The variable Q in the register addresses refers to the QCU number.

7.2.3.1 Tx Queue Descriptor (Q_TXDP)

Offset: 0x0800 + (Q << 2)

Access: Read/Write

Cold Reset: (Undefined)

Warm Reset: (Unaffected)

Bit	Name	Description
31:2	TXDP	Tx descriptor pointer
1:0	RES	Reserved

7.2.3.2 Tx Queue Enable (Q_TXE)

Offset: 0x0840

Access: Read/Write

Cold Reset: 0x0

Warm Reset: (Same as cold reset)

NOTE: Writing a 1 in bit position *N* sets the TXE bit for QCU *N*. Writing a 0 in bit position *N* has no effect; in particular, it does not clear the TXE bit for the QCU.

Bit	Description
31:10	Reserved
9	Enable QCU 9
...	...
1	Enable QCU 1
0	Enable QCU 0

7.2.3.3 Tx Queue Disable (Q_TXD)

Offset: 0x0880

Access: Read/Write

Cold Reset: 0x0

Warm Reset: (Same as cold reset)

NOTE:

To stop transmission for QCU *Q*:

1. Write a 1 to QCU *Q*'s TXD bit
2. Poll the "Tx Queue Enable (Q_TXE)" register until QCU *Q*'s TXE bit is clear
3. Poll QCU *Q*'s "Misc. QCU Status (Q_STS)" register until its pending frame count (Q_STS bits [1:0]) is zero
4. Write a 0 to QCU *Q*'s TXD bit

At this point, QCU *Q* has shut down and has no frames pending in its associated DCU.

Software must not write a 1 to a QCU's TXE bit when that QCU's TXD bit is set; an undefined operation will result. Software must ensure that it sets a QCU's TXE bit only when the QCU's TXD bit is clear. It is fine to write a 0 to TXE when TXD is set, but this has no effect on the QCU.

Bit	Description
31:10	Reserved
9	Enable QCU 9
...	...
1	Enable QCU 1
0	Enable QCU 0

7.2.3.4 CBR Configuration (Q_CBRCFG)

Offset: 0x08C0 + (Q << 2)

Access: Read/Write

Cold Reset: 0x0

Warm Reset: (Same as cold reset)

Bit	Name	Description
31:24	CBR_OVF_THRESH	CBR overflow threshold
23:0	CBR_INTV	CBR interval in μ s

7.2.3.5 ReadyTime Configuration (Q_RDYTIMECFG)

Offset: 0x0900 + (Q << 2)

Access: Read/Write

Cold Reset: 0x0

Warm Reset: (Same as cold reset)

Bit	Name	Description	
31:25	RES	Reserved	
24	RDYTIME_EN	ReadyTime enable	
		0	Disable ReadyTime use
		1	Enable ReadyTime use
23:0	RDYTIME_DUR	ReadyTime duration in μ s	

7.2.3.6 OneShotArm Set Control (Q_ONESHOTARM_SC)

Offset: 0x0940

Access: Read/Write

Cold Reset: 0x0

Warm Reset: (Same as cold reset)

NOTE: A read to this register returns the current state of all OneShotArm bits (QCU *Q*'s OneShotArm bit is returned in bit position *Q*).

Bit	Description	
31:10	Reserved	
9	0	No effect
	1	Set OneShot arm bit for QCU 9
...	...	
1	0	No effect
	1	Set OneShot arm bit for QCU 1
0	0	No effect
	1	Set OneShot arm bit for QCU 0

7.2.3.7 OneShotArm Clear Control (Q_ONESHOTARM_CC)

Offset: 0x0980

Access: Read/Write

Cold Reset: 0x0

Warm Reset: (Same as cold reset)

NOTE: A read to this register returns the current state of all OneShotArm bits (QCU *Q*'s OneShotArm bit is returned in bit position *Q*).

Bit	Description	
31:10	Reserved	
9	0	No effect
	1	Clear OneShot arm bit for QCU 9
...	...	
1	0	No effect
	1	Clear OneShot arm bit for QCU 1
0	0	No effect
	1	Clear OneShot arm bit for QCU 0

7.2.3.8 Misc. QCU Settings (Q_MISC)

Offset: 0x09C0 + (Q << 2)

Access: Read/Write

Cold Reset: (See field descriptions)

Warm Reset: (Same as cold reset)

Bit	Name	Reset	Description	
31:12	RES	0x0	Reserved	
11	QCU_FR_ABORT_REQ_EN	0x1	DCU frame early termination request control	
			0	Never request early frame termination. Once a frame enters the DCU, it will remain active until its normal retry count has been reached or the frame succeeds.
			1	Allow this QCU to request early frame termination. When requested, the DCU attempts to complete processing the frame more quickly than it normally would.
10	CBR_EXP_CNT_CLR_EN	0x0	CBR expired counter force-clear control. Write-only (always reads as zero). Write of:	
			0	No effect
			1	Resets the CBR expired counter to zero
9	TXE_CLR_ON_CBR_END	0x0	ReadyTime expiration and VEOL handling policy	
			0	On expiration of ReadyTime or on VEOL, the TXE bit is not cleared. Only reaching the physical end-of-queue (that is, a NULL LinkPtr) will clear TXE
			1	The TXE bit is cleared on expiration of ReadyTime, on VEOL, and on reaching the physical end-of-queue
8	CBR_EXP_INC_LIMIT	0x0	CBR expired counter limit enable	
			0	The maximum CBR expired counter value is 255, but a CBROVF interrupt is generated when the counter reaches the value set in the CBR overflow threshold field of the “ CBR Configuration (Q_CBRCFG) ” register.
			1	The maximum CBR expired counter is limited to the value of the CBR overflow threshold field of the “ CBR Configuration (Q_CBRCFG) ” register. Note that in addition to limiting the maximum CBR expired counter to this value, a CBROVF interrupt is also generated when the CBR expired counter reaches the CBR overflow threshold.
7	QCU_IS_BCN	0x0	Beacon use indication. Indicates whether the QCU is being used for beacons	
			0	QCU is being used for non-beacon frames only
			1	QCU is being used for beacon frames (and possibly for non-beacon frames)
6	CBR_EXP_INC_DIS_NOBCNFR	0x0	Disable the CBR expired counter increment if the frame scheduling trigger occurs and the QCU marked as being used for beacon transmission (i.e., the QCU that has bit [7] set in its “ Misc. QCU Settings (Q_MISC) ” register) contains no frames	
			0	Increment the CBR expired counter each time the frame scheduling trigger occurs, regardless of whether the beacon queue contains frames
			1	Increment the CBR expired counter only when both the frame scheduling trigger occurs and the beacon queue is valid (the beacon queue is valid whenever its TXE is asserted)

Bit	Name	Reset	Description	
5	CBR_EXP_INC_DIS_NOFR	0x0	Disable the CBR expired counter increment if the frame scheduling trigger occurs and the queue contains no frames	
			0	Increment the CBR expired counter each time the frame scheduling trigger occurs, regardless of whether the queue contains frames
			1	Increment the CBR expired counter only when both the frame scheduling trigger occurs and the queue is valid (the queue is valid whenever TXE is asserted)
4	ONESHOT_EN	0x0	OneShot enable	
			0	Disable OneShot function
			1	Enable OneShot function Note that OneShot must not be enabled when the QCU is set to an ASAP frame scheduling policy.
3:0	FSP	0x0	Frame scheduling policy setting	
			0	ASAP The QCU is enabled continuously.
			1	CBR The QCU is enabled under control of the settings in the “ CBR Configuration (Q_CBRCFG) ” register.
			2	DBA-gated The QCU will be enabled at each occurrence of a DMA beacon alert.
			3	TIM-gated The QCU will be enabled whenever: <ul style="list-style-type: none"> ■ In STA mode, the PCU indicates that a beacon frame has been received with the local STA’s bit set in the TIM element ■ In IBSS mode, the PCU indicates that an ATIM frame has been received
			4	Beacon-sent-gated The QCU will be enabled when the DCU that is marked as being used for beacon transmission (see bit [16] of the “ CBR Configuration (Q_CBRCFG) ” register) indicates that it has sent the beacon frame on the air
			5	Beacon-received-gated The QCU will be enabled when the PCU indicates that it has received a beacon.
			6	HCF Poll gated The QCU will be enabled whenever the Rx HCF poll event occurs; the signals come from the PCU when a directed HCF poll frame type is received with valid FCS.
			15:7	Reserved

7.2.3.9 Misc. QCU Status (Q_STS)

Offset: 0x0A00 + (Q << 2)

Access: Read-Only

Cold Reset: 0x0

Warm Reset: (Same as cold reset)

Bit	Description
31:16	Reserved
15:8	Current value of the CBR expired counter
7:2	Reserved
1:0	Pending frame count Indicates the number of frames this QCU presently has pending in its associated DCU.

7.2.3.10 ReadyTimeShutdown Status (Q_RDYTIMESHDN)

Offset: 0x0A40

Access: Read/Write

Cold Reset: 0x0

Warm Reset: (Same as cold reset)

Bit	Description
31:10	Reserved
9	ReadyTimeShutdown status for QCU 9
...	...
1	ReadyTimeShutdown status for QCU 1
0	ReadyTimeShutdown status for QCU 0 On read, returns ReadyTimeShutdown indication. Write of:
0	No effect
1	Set OneShot arm bit for QCU 0

7.2.4 DCU Registers

The DCU registers occupy the offset range 0x1000– 0x12F0 in the AR9287 address space. The AR9287 has ten DCUs, numbered from 0 to 9.

Table 7-7. QCU Registers

Offset	Name	Description	Page
0x1000 + (D << 2) ^[1]	D_QCUMASK	QCU Mask	page 76
0x1040 + (D << 2) ^[1]	D_LCL_IFS	DCU-Specific IFS Settings	page 77
0x1080 + (D << 2) ^[1]	D_RETRY_LIMIT	Retry Limits	page 77
0x10C0 + (D << 2) ^[1]	D_CHNTIME	ChannelTime Settings	page 78
0x1100 + (D << 2) ^[1]	D_MISC	Miscellaneous DCU-Specific Settings	page 78
0x1030	D_GBL_IFS_SIFS	DCU-Global IFS Settings: SIFS Duration	page 81
0x1070	D_GBL_IFS_SLOT	DCU-Global IFS Settings: Slot Duration	page 81
0x10B0	D_GBL_IFS_EIFS	DCU-Global IFS Settings: EIFS Duration	page 81
0x10F0	D_GBL_IFS_MISC	DCU-Global IFS Settings: Misc. Parameters	page 82
0x1270	D_TXPSE	DCU Transmit Pause Control/Status	page 83
0x12F0	D_TXSLOTMASK	DCU Transmission Slot Mask	page 83
(Varies)	D_TXBLK	DCU Transmit Filter Bits	page 84

[1]The variable *D* in the register addresses refers to the DCU number.

7.2.4.1 QCU Mask (D_QCUMASK)

Offset: 0x1000 + (D << 2)
 Access: Read/Write
 Cold Reset: 0x0
 Warm Reset: (Unaffected)

NOTE: To achieve lowest power consumption, software should set this register to 0x0 for all DCUs that are not in use. The hardware detects that the QCU mask is set to zero and shuts down certain logic in response, helping to save power.

Bit	Name	Description
31:10	RES	Reserved
9:0	QCU_MASK	QCU mask Setting bit <i>Q</i> means that QCU <i>Q</i> is associated with (i.e., feeds into) this DCU. These register have reset values which corresponding to a 1 to 1 mapping between QCUs and DCUs. A register offset of 0x1000 maps to QCU_MASK [0], 0x1004 maps to QCU_MASK [1], 0x1008 maps to QCU_MASK [3], etc.

7.2.4.2 DCU-Specific IFS Settings (*D_LCL_IFS*)

Offset: 0x1040 + (*D* << 2)

Access: Read/Write

Cold Reset: (See field descriptions)

Warm Reset: (Unaffected)

Bit	Name	Reset	Description
When Long AIFS is 0:			
31:28	RES	0x0	Reserved
27:20	DATA_AIFS_D[7:0]	0x2	AIFS value, in slots beyond SIFS For example, a setting of 2 (the reset value) means AIFS is equal to DIFS. NOTE: Although this field is 17 bits wide (including the 9 MSBs accessed using the long AIFS field), the maximum supported AIFS value is 0x1FFFC. Setting the AIFS value to 0x1FFFD, 0x1FFFE, or 0x1FFFF does not work correctly and causes the DCU to hang.
19:10	DATA_CW_MAX	0x3FF	CW_MAX value; must be equal to a power of 2, minus 1
9:0	DATA_CW_MIN	0xF	CW_MIN value; must be equal to a power of 2, minus 1
When Long AIFS is 1:			
31:29	RES	0x0	Reserved
28	LONG_AIFS [DCU_IDX_D]	0x0	Long AIFS bit; used to read or write to the nine MSBs of the AIFS value
27:9	RES	0x0	Reserved
8:0	DATA_AIFS_D[16:8]	0x2	Upper nine bits of the AIFS value (see bits [27:20] listed in this register)

7.2.4.3 Retry Limits (*D_RETRY_LIMIT*)

Offset: 0x1080 + (*D* << 2)

Access: Read/Write

Cold Reset: (See field descriptions)

Warm Reset: (Unaffected)

Bit	Name	Reset	Description
31:20	RES	0x20	Reserved
19:14	SDFL	0x20	STA data failure limit Specifies the number of times a frame's data exchange may fail before CW is reset to CW_MIN. Note: A value of 0x0 is unsupported.
13:8	SRFL	0x20	STA RTS failure limit Specifies the number of times a frame's RTS exchange may fail before the CW is reset to CW_MIN. Note: A value of 0x0 is unsupported.
7:4	RES	0x0	Reserved
3:0	FRFL	0x4	Frame RTS failure limit Specifies the number of times a frame's RTS exchange may fail before the current transmission series is terminated. A frame's RTS exchange fails if RTS is enabled for the frame, but when the MAC sends the RTS on the air, no CTS is received. Note: A value of 0x0 is unsupported.

7.2.4.4 ChannelTime Settings (D_CHNTIME)

Offset: 0x10C0 + (D << 2)

Access: Read/Write

Cold Reset: 0x0

Warm Reset: (Unaffected)

Bit	Name	Description	
31:21	RES	Reserved	
20	CHANNEL_TIME_EN	ChannelTime enable	
		0	Disable ChannelTime function
		1	Enable ChannelTime function
19:0	DATA_CT_MMR	ChannelTime duration in μ s	

7.2.4.5 Misc. DCU-Specific Settings (D_MISC)

Offset: 0x1100 + (D << 2)

Access: Read/Write

Cold Reset: (See field descriptions)

Warm Reset: (Unaffected)

Bit	Name	Reset	Description	
31:24	RES	0x0	Reserved	
23	RETRY_ON_BLOWN_IFS_EN	0x0	Blown IFS handling policy This setting controls how the DCU handles the case in which the DMA of a frame takes so long that the IFS spacing is met before the frame trigger level is reached.	
			0	Send the frame on the air anyway (i.e., ignore the IFS violation). This will cause the frame to be sent on the air at a time that is later than called for in the 802.11 spec.
			1	Do not send the frame on the air. Instead, act as if the frame had been sent on the air but failed and initiate the retry procedure. A retry will be charged against the frame. If more retries are permitted, the frame will be retried. If the retry limit has been reached, the frame will fail.
22	VIRT_COLL_CW_INC_EN	0x0	Virtual collision CW increment policy	
			0	Virtual collisions do not increment (advance) the frame's contention window (CW)
			1	Virtual collisions do increment the frame's contention window (CW)
21	RES	0x0	Reserved	
20	SEQNUM_FREEZE	0x0	Sequence number increment disable	
			0	Allow the DCU to use a normal sequence number progression (the DCU increments the sequence number for each new frame)
			1	Force the sequence number to be frozen at its current value

Bit	Name	Reset	Description	
19	DCU_ARB_LOCKOUT_IGNORE	0x0	DCU arbiter lockout ignore control	
			0	Obey DCU arbiter lockouts from higher-priority DCUs
			1	Ignore DCU arbiter lockouts from higher-priority DCUs (i.e., allow the current DCU to arbitrate for access to the PCU even if one or more higher-priority DCUs is asserting a DCU arbiter lockout)
18:17	DCU_ARB_LOCKOUT_IF_EN	0x0	DCU arbiter lockout control	
			0	No lockout. Allows lower-priority DCUs to arbitrate for access to the PCU concurrently with this DCU.
			1	Intra-frame lockout only. Forces all lower-priority DCUs to defer arbitrating for access to the PCU while the current DCU is either arbitrating for access to the PCU or performing an intra-frame backoff.
			2	Global lockout. Forces all lower-priority DCUs to defer arbitrating for access to the PCU whenever: <ul style="list-style-type: none"> ■ At least one of the QCUs that feed into the current DCU has a frame ready ■ The current DCU is actively processing a frame (i.e., is not idle). This includes arbitrating for access to the PCU, performing an intra-frame or post-frame backoff, DMA'ing frame data to the PCU, or waiting for the PCU to complete the frame.
		3	Reserved	
16	DCU_IS_BRN	0x0	Beacon use indication Indicates whether the DCU is being used for beacons.	
			0	DCU is being used for non-beacon frames only
			1	DCU is being used for beacon frames only
15:14	VIRT_COLL_POLICY	0x0	Virtual collision handling policy	
			0	Default handling. A virtual collision is processed such as a collision on the air except that the retry count for the frame is not incremented (i.e., just perform the backoff).
			1	Ignore. Virtual collisions are ignored (i.e., the DCU immediately rearbitrates for access to the PCU without doing a backoff or incrementing the retry count).
		3:2	Reserved	
13	RES	0x0	Reserved	
12	MEM_RD_DATA_PF	0x1	Backoff persistence factor setting	
			0	New CW equals old CW
		1	Use binary-exponential CW progression	
11:10	RES	0x0	Reserved	
9	FRAG_BURST_BKOFF_EN	0x0	Fragment burst backoff policy This bit controls whether the DCU performs a backoff after each transmission of a fragment (i.e., a frame with the MoreFrag bit set in the frame control field).	
			0	The DCU handles fragment bursts normally
			1	Modified handling. The DCU performs a backoff after all fragments, even those transmitted successfully.

Bit	Name	Reset	Description	
8	FRAG_BURST_WAIT_QCU_EN	0x0	Fragment burst frame starvation handling policy This bit controls the DCU operation when the DCU is in the middle of a fragment burst and finds that the QCU sourcing the fragments does not have the next fragment available.	
			0	The DCU terminates the fragment burst. Note that when this occurs, the remaining fragments (when the QCU eventually has them available) will be sent as a separate fragment burst with a different sequence number.
			1	The DCU waits for the QCU to have the next fragment available. While doing so, all other DCUs will be unable to transmit frames.
7	TS_END_DIS	0x0	End of transmission series CW reset policy This bit controls only whether the contention window is reset when transitioning from one transmission series to the next within a single frame. The CW is reset per the 802.11 spec when the entire frame attempt terminates (because the frame was sent successfully or because all transmission series failed).	
			0	Reset the CW to CW_MIN at the end of each intraframe transmission series
			1	Do not reset the CW at the end of each intraframe transmission series
6	SFC_RST_AT_TS_END_EN	0x0	End of transmission series station RTS/data failure count reset policy Note that this bit controls only whether the two STA failure counts are reset when transitioning from one transmission series to the next within a single frame. The counts are reset per the 802.11 spec when the entire frame attempt terminates (either because the frame was sent successfully or because all transmission series failed).	
			0	Do not reset the station RTS failure count or the STA data failure count at the end of each transmission series
			1	Reset both the station RTS failure count and the STA data failure count at the end of each transmission series
5:0	DATA_BKOFF_THRESH	0x2	Backoff threshold setting Determines the backoff count at which the DCU will initiate arbitration for access to the PCU and commit to sending the frame.	

7.2.4.6 DCU-Global IFS Settings: SIFS Duration (D_GBL_IFS_SIFS)

Offset: 0x1030

Access: Read/Write

Cold Reset: 640 (16 μ s at 40 MHz)

Warm Reset: (Unaffected)

Bit	Name	Description
31:16	RES	Reserved
15:0	SIFS_DUR	SIFS duration in core clocks (40 MHz in non-Turbo mode, 80 MHz in Turbo mode)

7.2.4.7 DCU-Global IFS Settings: Slot Duration (D_GBL_IFS_SLOT)

Offset: 0x1070

Access: Read/Write

Cold Reset: 360 (9 μ s at 40 MHz)

Warm Reset: (Unaffected)

Bit	Name	Description
31:16	RES	Reserved
15:0	SLOT_DUR	Slot duration in core clocks (40 MHz in non-Turbo mode, 80 MHz in Turbo mode)

7.2.4.8 DCU-Global IFS Settings: EIFS Duration (D_GBL_IFS{EIFS})

Offset: 0x10B0

Access: Read/Write

Cold Reset: 3480 (87 μ s at 40 MHz)

Warm Reset: (Unaffected)

Bit	Name	Description
31:16	RES	Reserved
15:0	EIFS_DUR	EIFS duration in core clocks (40 MHz in non-Turbo mode, 80 MHz in Turbo mode)

7.2.4.9 DCU-Global IFS Settings: Misc. Parameters (D_GBL_IFS_MISC)

Offset: 0x10F0

Access: Read/Write

Cold Reset: (See field descriptions)

Warm Reset: (Unaffected)

Bit	Name	Reset	Description	
31:29	RES	0x0	Reserved	
26:25	CHAN_SLOT_WIN_DUR	0x0	Slot transmission window length Specifies the number of core clocks after a slot boundary during which the MAC is permitted to send a frame. Specified in units of 8 core clocks, with the value 0x0 being special. If set to a value of 0x0 (the reset value), the MAC is permitted to send at any point in the slot.	
28	IGNORE_BACKOFF	0x0	Ignore back off Allows the DCU to ignore backoff as well as EIFS; it should be set during fast channel change to guarantee low latency and flush the Tx pipe.	
27	CHAN_SLOT_ALWAYS	0x0	Force transmission always on slot boundaries When bits [26:25] of this register are non-zero, the MAC transmits on slot boundaries as required by the 802.11 spec. When bits [26:25] are not 0x0 and this bit is non-zero, the MAC always transmits on slot boundaries.	
24	LFSR_SLICE_RANDOM_DIS	0x0	Random LFSR slice selection disable	
			0	Allow the IFS logic to randomly generate the LFSR slice select value (see bits [2:0] of this register). The random selection ensures independence of the LFSR output values both for nodes on different PCIE busses but on the same network as well as for multiple nodes connected to the same physical PCIE bus.
			1	Disable random LFSR slice selection and use the value of the LFSR slice select field (bits [2:0] of this register) instead
23	AIFS_RST_UNCOND	0x0	AIFS counter reset policy (debug use only)	
			0	Reset the AIFS counter only when PCU_RST_AIFS is asserted and the counter already has reached AIFS
			1	Reset the AIFS counter unconditionally whenever PCU_RST_AIFS is asserted
22	SIFS_RST_UNCOND	0x0	SIFS counter reset policy (debug use only)	
			0	Reset the SIFS counter only when PCU_RST_SIFS is asserted and the counter already has reached SIFS
			1	Reset the SIFS counter unconditionally whenever PCU_RST_SIFS is asserted
21:3	RES	0x0	Reserved	
2:0	LFSR_SLICE_SEL	0x0	LFSR slice select Determines which slice of the internal LFSR will generate the random sequence used to determine backoff counts in the PCU's DCUs and scrambler seeds. This allows different STAs to contain different LFSR slice values (e.g., by using bits from the MAC address) to minimize random sequence correlations among STAs in the same BSS/IBSS. NOTE: This field affects the MAC only when the random LFSR slice selection disable bit (bit [24] of this register) is set. When random LFSR slice selection is enabled (the default), this field is ignored.	

7.2.4.10 DCU Tx Pause Control/Status (D_TXPSE)

Offset: 0x1270

Access: Read/Write

Cold Reset: (See field descriptions)

Warm Reset: (Unaffected)

Bit	Name	Reset	Description	
31:17	RES	0x0	Reserved	
16	TX_PAUSED	0x1	Tx pause status	
			0	Tx pause request has not yet taken effect, so some DCUs for which a transmission pause request has been issued using bits [9:0] of this register are still transmitting and have not paused.
			1	All DCUs for which a transmission pause request has been issued via bits [9:0] of this register, if any, have paused their transmissions. Note that if no transmission pause request is pending (i.e., bits [9:0] of this register are all set to 0), then this Tx pause status bit will be set to one.
15:10	RES	0x0	Reserved	
9:0	DCU_REG_TXPSE	0x0	Request that some subset of the DCUs pause transmission. For bit D of this field ($9 \geq D \geq 0$):	
			0	Allow DCU D to continue to transmit normally
			1	Request that DCU D pause transmission as soon as it is able

7.2.4.11 DCU Transmission Slot Mask (D_TXSLOTMASK)

Offset: 0x12F0

Access: Read/Write

Cold Reset: 0x0

Warm Reset: (Unaffected)

NOTE: When bits [26:25] of the “DCU-Global IFS Settings: Misc. Parameters (D_GBL_IFS_MISC)” register are non-zero, D_TXSLOTMASK controls the slots DCUs can start frame transmission on. The slot occurring coincident with SIFS elapsing is slot 0. Slot numbers increase thereafter, whether the channel was idle or busy during the slot. If bits [26:25] of D_GBL_IFS_MISC are zero, this register has no effect.

Bit	Description	
31:16	Reserved	
15	Specifies whether transmission may start on slot numbers that are congruent to 15 (mod 16)	
	0	Transmission may start on such slots
	1	Transmission may not start on such slots
...	...	
1	Specifies whether transmission may start on slot numbers that are congruent to 1 (mod 16)	
	0	Transmission may start on such slots
	1	Transmission may not start on such slots
0	Specifies whether transmission may start on slot numbers that are congruent to 0 (mod 16)	
	0	Transmission may start on such slots
	1	Transmission may not start on such slots

7.2.4.12 DCU Tx Filter Bits (D_TXBLK)

Offset: Varies (see Table 7-8)

Access: Read/Write

Cold Reset: 0x0

Warm Reset: (Unaffected)

Each DCU has 128 Tx filter bits, for a total of $10 * 128 = 1280$ Tx filter bits for all ten DCUs.

For reads of the Tx filter bits, the 1280 bits are accessed via reads within a range of 64 32-bit register locations.

For writes of the Tx filter bits, only three of the 64 register locations are used. One location allows specific bits of a specific DCU's Tx filter bits to be set or cleared. Two other locations allow all 128 Tx filter bits for any subset of the ten DCUs to be set or cleared atomically.

For both reads and writes, the PCIE offset issued by the host is mapped to one of the 64 register locations. The 6-bit internal address resulting from mapping is called MMR_ADDR, and its value controls what portion of the Tx filter bits is affected by the host's register read or write. In general, the address offset that maps to the internal MMR_ADDR is given by the equation:

$$\text{Address offset} = 0x1038 + ((\text{mmr_addr} \& 0x1f) \ll 6) + ((\text{mmr_addr} \& 0x20) \gg 3)$$

Thus the proper address offset can be determined from the desired MMR_ADDR (see Table 7-8).

Table 7-8. MMR_ADDR and Address Offset

MMR_ADDR	Address Offset
0	0x1038
1	0x1078
2	0x10B8
3	0x10F8
4	0x1138
5	0x1178
6	0x11B8
7	0x11F8
8	0x1238
9	0x1278
10	0x12B8
11	0x12F8
12	0x1338

Table 7-8. MMR_ADDR and Address Offset

MMR_ADDR	Address Offset
13	0x1378
14	0x13B8
15	0x13F8
16	0x1438
17	0x1478
18	0x14B8
19	0x14F8
20	0x1538
21	0x1578
22	0x15B8
23	0x15F8
24	0x1638
25	0x1678
26	0x16B8
27	0x16F8
28	0x1738
29	0x1778
30	0x17B8
31	0x17F8
...	...
48	0x143C
49	0x147C

Writes

Only three register locations (MMR_ADDR values) are supported for writes. Writes to other values yield undefined results and may corrupt Tx filter bits.

Table 7-9. MMR_ADDR Usage for Tx Filter Bits (Write Data)

MMR_ADDR	Description																																										
49	Sets all 128 filter bits for each DCU that has a 1 in bits [9:0] of the write data (e.g., a write of 0x5 to address 49 causes all 128 filter bits for DCUs 0 and 2 to be set)																																										
48	Clears all 128 filter bits for each DCU that has a 1 in bits [9:0] of the write data (e.g., a write of 0x5 to address 48 causes all 128 filter bits for DCUs 0 and 2 to be cleared)																																										
0	Allows individual bits of a particular DCU's 128 Tx filter bits to modify. The write data determines which bits are affected and what operation is performed. The write data is split into several fields: <table border="1" style="width: 100%; border-collapse: collapse;"> <tr> <td style="width: 10%;">31:28</td> <td colspan="2">Reserved</td> </tr> <tr> <td rowspan="4">27:24</td> <td colspan="2">Command; determines what operation will be performed on the selected filter bits:</td> </tr> <tr> <td style="width: 10%;">0</td> <td>Clear the selected bits</td> </tr> <tr> <td>1</td> <td>Set the selected bits</td> </tr> <tr> <td>15:2</td> <td>Reserved</td> </tr> <tr> <td>23:20</td> <td colspan="2">DCU number; determines which DCU's Tx filter bits are affected by writes. Setting this field to a value of D ($9 \geq D \geq 0$) causes DCU D's Tx filter bits to be affected by the write.</td> </tr> <tr> <td rowspan="5">19:16</td> <td colspan="2">Slice number; selects a 16-bit bitslice from the selected DCU's 128 affected Tx filter bits:</td> </tr> <tr> <td>0</td> <td>Filter bits [15:0] are affected</td> </tr> <tr> <td>1</td> <td>Filter bits [31:16] are affected</td> </tr> <tr> <td>...</td> <td>...</td> </tr> <tr> <td>7</td> <td>Filter bits [127:112] are affected</td> </tr> <tr> <td>15:8</td> <td colspan="2">Reserved</td> </tr> <tr> <td rowspan="5">15:0</td> <td colspan="2">Bitmask; controls which bits within the selected bitslice are affected. Bit N ($15 \geq N \geq 0$) of the bitmask affects bit N of the selected bitslice (see examples):</td> </tr> <tr> <td>0</td> <td>Bit N remains unchanged</td> </tr> <tr> <td>1</td> <td>Bit N of the selected bitslice is modified per the command field (bits [27:24])</td> </tr> <tr> <td colspan="2">Example Write Data Example Effect</td> </tr> <tr> <td>0x130404</td> <td>Clears bits [50] and [58] of DCU 1's Tx filter bits</td> </tr> <tr> <td>0x00978001</td> <td>Clears bits [127] and [112] of DCU 9's Tx filter bits</td> </tr> </table>	31:28	Reserved		27:24	Command; determines what operation will be performed on the selected filter bits:		0	Clear the selected bits	1	Set the selected bits	15:2	Reserved	23:20	DCU number; determines which DCU's Tx filter bits are affected by writes. Setting this field to a value of D ($9 \geq D \geq 0$) causes DCU D 's Tx filter bits to be affected by the write.		19:16	Slice number; selects a 16-bit bitslice from the selected DCU's 128 affected Tx filter bits:		0	Filter bits [15:0] are affected	1	Filter bits [31:16] are affected	7	Filter bits [127:112] are affected	15:8	Reserved		15:0	Bitmask; controls which bits within the selected bitslice are affected. Bit N ($15 \geq N \geq 0$) of the bitmask affects bit N of the selected bitslice (see examples):		0	Bit N remains unchanged	1	Bit N of the selected bitslice is modified per the command field (bits [27:24])	Example Write Data Example Effect		0x130404	Clears bits [50] and [58] of DCU 1's Tx filter bits	0x00978001	Clears bits [127] and [112] of DCU 9's Tx filter bits
31:28	Reserved																																										
27:24	Command; determines what operation will be performed on the selected filter bits:																																										
	0	Clear the selected bits																																									
	1	Set the selected bits																																									
	15:2	Reserved																																									
23:20	DCU number; determines which DCU's Tx filter bits are affected by writes. Setting this field to a value of D ($9 \geq D \geq 0$) causes DCU D 's Tx filter bits to be affected by the write.																																										
19:16	Slice number; selects a 16-bit bitslice from the selected DCU's 128 affected Tx filter bits:																																										
	0	Filter bits [15:0] are affected																																									
	1	Filter bits [31:16] are affected																																									
																																									
	7	Filter bits [127:112] are affected																																									
15:8	Reserved																																										
15:0	Bitmask; controls which bits within the selected bitslice are affected. Bit N ($15 \geq N \geq 0$) of the bitmask affects bit N of the selected bitslice (see examples):																																										
	0	Bit N remains unchanged																																									
	1	Bit N of the selected bitslice is modified per the command field (bits [27:24])																																									
	Example Write Data Example Effect																																										
	0x130404	Clears bits [50] and [58] of DCU 1's Tx filter bits																																									
0x00978001	Clears bits [127] and [112] of DCU 9's Tx filter bits																																										

Reads

Table 7-10. MMR_ADDR Usage for Tx Filter Bits (Read Data)

MMR_ADDR	Description
49:48	No effect
39:36	Returns filter bits for DCU 9, bits [31:0] – [127:96]
...	...
7:4	Returns filter bits for DCU 1, bits [31:0] – [127:96]
3	Returns filter bits for DCU 0, bits [127:96]
2	Returns filter bits for DCU 0, bits [95:64]
1	Returns filter bits for DCU 0, bits [63:32]
0	Returns filter bits for DCU 0, bits [31:0]

7.2.5 MAC Interface

The MAC DMA occupies offset range 0x0000 to 0x1FFC in the AR9287 address space. Within this 8 K Byte range the address range consists of “always on” registers that are available for software access regardless of whether the MAC is asleep. [Table 7-11](#) lists these registers.

Table 7-11. Always On Registers in the MAC

Offset	Name	Description	Page
0x1F00	MAC_SLEEP	MAC Sleep Status	page 86
0x1F04	MAC_LED	MAC LED Control Register	page 86

7.2.5.1 MAC Sleep Status Register (MAC_SLEEP)

Offset: 0x1F00

Access: Read Only

Reset: Undefined

Bit	Name	Description
31:2	RES	Reserved
0	MAC_SLEEP	When this bit is 0, MAC is awake. When this bit is 1, MAC is asleep.

7.2.5.2 MAC LED Control Register (MAC_LED)

Offset: 0x1F04

Access: Read/Write

Reset: 0x0

Bit	Name	Description
31:12	RES	Reserved
11	PENDING	Association Pending
10	ACTIVE	Association active
9:7	LED_MODE	LED mode select
6:4	LED_BLK_THD	LED blink threshold select
3	LED_SLOW_BLK	LED slowest blink rate mode
2	LED_HYS_DIS	LED hysteresis disable
1:0	SLEEP_CLK_RATE	Sleep clock rate

7.2.6 EEPROM Interface Registers

This EEPROM registers access the external EEPROM. Upon power reset, a state machine inside the host interface reads the EEPROM and writes registers within the AR9287. The EEPROM map is shown in Figure 7-1:

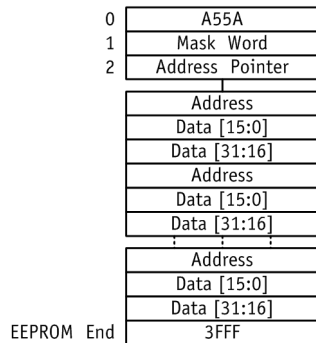

Figure 7-1. EEPROM Address Map

Each EEPROM location is 16 bits wide. As shown in Figure 7-1, the first location must contain the 16-bit word A55A, indicating that the EEPROM is valid. If the first location is not this value, then the state machine assumes the EEPROM contents have been corrupted and immediately stops running.

The next EEPROM location contains the mask word as described. Location 2 contains an address pointer to the next valid data segment. Each data segment consists of three locations: a 16-bit address location and two locations for the 32-bit write data as shown in Figure 7-1. The state machine reads each data segment and writes to the corresponding AR9287 register. The state machine stops when it comes to an address equal to 3FFF.

7.2.7 Host Interface Registers

Table 7-12. Host Interface Registers

Offset	Name	Description	Page
0x4000	H_RC	Reset the MAC AHB/APB Interface	page 88
0x4014	H_PM_CTRL	Host Power Management Control	page 88
0x4018	H_TIMEOUT	Host Timeout	page 89
0x401C	H_EEPROM_CTRL	EEPROM Control	page 89
0x4020	H_SREV_ID	MAC Silicon Revision ID	page 89
0x4028	H_INTR_CAUSE_CLR	Interrupt Cause Clear	page 90
0x4028	H_INTR_SYNC_CAUS	Synchronous Interrupt Cause	page 90
0x402C	H_INTR_SYNC_ENAB	Synchronous Interrupt Enable	page 91
0x4030	H_INTR_ASYNC_MASK	Asynchronous Interrupt Mask	page 91
0x4034	H_INTR_SYN_MASK	Synchronous Interrupt Mask	page 91
0x4038	H_INTR_ASYNC_CAUS	Asynchronous Interrupt Cause	page 91
0x403C	H_INTR_ASYNC_ENAB	Asynchronous Interrupt Enable	page 92
0x4040	H_PHY_RW	PCIE PHY RW	page 92
0x4044	H_PHY_LOAD	PCIE PHY Load	page 92
0x4048	H_GPIO_IN_OUT	GPIO Input and Output	page 92
0x404C	H_GPIO_OE_BITS	GPIO Output Enable Bits	page 93
0x4050	H_GPIO_IRQ_POLAR	GPIO Interrupt Polarity	page 93
0x4054	H_GP_INPT_EN_VAL	GPIO Input Enable and Value	page 94
0x4058	H_GP_INPT_MUX1	GPIO Input MUX1	page 94
0x405C	H_GP_INPT_MUX2	GPIO Input MUX2	page 95
0x4060	H_GP_OUTPT_MUX1	GPIO Output MUX1	page 95
0x4064	H_GP_OUTPT_MUX2	GPIO Output MUX2	page 95
0x406C	H_INPUT_STATE	Input Values	page 96
0x407C	H_EEP_STS_DATA	EEPROM Status and Read Data	page 97
0x4084	H_RFSILENT	RFsilent-Related Registers	page 97
0x4088	H_GPIO_PDPUP	GPIO Pull-Up/Pull-Down	page 98
0x408C	H_GPIO_DS	GPIO Drive Strength	page 98
0x4094	H_PCIE_MSI	MSI Interrupt Enable	page 99
0x4098	H_SAFE_MODE_EN	Safe Mode Enable	page 99

7.2.7.1 Reset the MAC AHB/APB Interface (H_RC)

Offset: 0x4000
 Access: Read/Write
 Reset Value: 0000_0000

Bit	Description	
31:9	Reserved	
8	0	Normal host master interface
	1	Hold PCIE master interface in reset
7:2	Reserved	
1	0	Normal MAC APB interface operation
	1	Hold MAC APB interface in reset
0	0	Normal MAC AHB interface operation
	1	Hold MAC AHB interface in reset

7.2.7.2 Host Power Management Control (H_PM_CTRL)

Offset: 0x4014
 Access: Read/Write
 Reset Value: See field description

Bit	Name	Reset	Description	
31:29	RES	0	Reserved	
28	AUX_PWR_DET	0	Goes directly to the PCIE core; used when software wants to put the AR9287 into the L2 state (using the L2/L3 handshake sequence)	
27:24	PWR_STATE_MASK	0x8	Power state mask; each bit corresponds to a power state. A 1 in any field indicates that a WoW event can be generated in the corresponding power state.	
			Bit [10]	D3
			Bit [9]	D2
			Bit [8]	D1
23	RES	0	Reserved	
			Reserved	
22	HOST_PME_ENABLE	0	Overrides the PME Enable bit in the PMCSR. Used for sending an out-of-band PCIE_WAKE_L signal when a WoW event occurs.	
21	WOW_PME_CLEAR	0	After a WoW event occurs, software can read the status in the AR9287 configuration space as well as in the MAC WoW registers. It must then set and clear this bit for the next WoW event.	
20:0	RES	0	Reserved	

7.2.7.3 Host Timeout (H_TIMEOUT)

Offset: 0x4018

Access: Read/Write

Reset Value: 1000_1000

Bit	Description
31:16	AHB bus timeout counter for DMA transfers
15:0	APB bus timeout counter for register access

7.2.7.4 EEPROM Control (H_EEPROM_CTRL)

Offset: 0x401C

Access: Read/Write

Reset Value: 0000_00FC

Bit	Description	
31:26	Reserved	
25:10	EEPROM protect mask	
9	EEPROM is corrupt	
8	EEPROM not present	
7:2	CLKDIV value for the APB EEPROM module	
1	0	Normal operation of the APB EEPROM module
	1	Reserved
0	0	Normal operation of the APB EEPROM module
	1	Reserved

7.2.7.5 MAC Silicon Revision ID (H_SREV_ID)

Offset: 0x4020

Access: Read-Only

Reset Value: 0x18_12FF

Bit	Description	
31:18	6	Version
17:12	1	Type
11:8	2	Revision
7:0	255	Old revision

Table 7-13 describes all of the signals capable of generating a system interrupt and lists their corresponding bits. The bits are the same for synchronous as well as asynchronous interrupts.

Table 7-13. System Interrupt Registers: Bit Descriptions

Bit	Name	Description
31:27	RES	Reserved
27:18	GPIO_INT	GPIO interrupt, bit 18 corresponds to GPIO0, bit 19 corresponds to GPIO1, ..., bit 27 corresponds to GPIO9.
17	MAC_SLEEP_ACCESS	Software is trying to access a register within the MAC while it is asleep
16	MAC_ASLEEP	The MAC has gone to sleep
15	MAC_AWAKE	The MAC has become awake
14	PM_ACCESS	The AHB master is requesting that a DMA transfer to the core while it is asleep
13	LOCAL_TIMEOUT	A local bus timeout has occurred
12:4	RES	Reserved
3	APB_TIMEOUT	No response from one of the AR9287 modules within the programmed timeout period during a register access
2	EEPROM_ILLEGAL_ACCESS	Software attempted to either access a protected area within the EEPROM, or access the EEPROM while it is busy or absent
1	MAC_IRQ	The MAC has requested an interrupt
0	RTC_IRQ	The RTC is in shutdown state

7.2.7.6 Interrupt Cause Clear (H_INTR_CAUSE_CLR)

Offset: 0x4028
 Access: Write-Only
 Reset Value: 0000_0000

Bit	Description
31:0	Writing a 1 to any bit in this register clears the corresponding bit in the “Interrupt Cause Clear (H_INTR_CAUSE_CLR)” register. See Table 7-13 for bit descriptions.

7.2.7.7 Synchronous Interrupt Cause (H_INTR_SYNC_CAUS)

Offset: 0x4028
 Access: Read-Only
 Reset Value: 0000_0000

Bit	Description
31:0	Setting any bit in this register indicates that the corresponding interrupt has been triggered in synchronous mode; for any bit to be set in this register, the corresponding bit in the “Synchronous Interrupt Enable (H_INTR_SYNC_ENAB)” register must also be set. See Table 7-13 for bit descriptions.

7.2.7.8 Synchronous Interrupt Enable (H_INTR_SYNC_ENAB)

Offset: 0x402C

Access: Read/Write

Reset Value: 0000_0000

Bit	Description
31:0	Setting any bit in this register allows the corresponding interrupt signal to set its corresponding bit in the “Synchronous Interrupt Cause (H_INTR_SYNC_CAUS)” register. See Table 7-13 for bit descriptions.

7.2.7.9 Asynchronous Interrupt Mask (H_INTR_ASYNC_MASK)

Offset: 0x4030

Access: Read/Write

Reset Value: 0000_0002

Bit	Description
31:0	Setting any bit in this register allows the corresponding interrupt signal to trigger a PCIE interrupt provided that the corresponding “Asynchronous Interrupt Cause (H_INTR_ASYNC_CAUS)” register bit is set. Note that for this register bit to be set, the corresponding “Asynchronous Interrupt Enable (H_INTR_ASYNC_ENAB)” register bit must also be set by software. See Table 7-13 for bit descriptions.

7.2.7.10 Synchronous Interrupt Mask (H_INTR_SYNC_MASK)

Offset: 0x4034

Access: Read/Write

Reset Value: 0000_0000

Bit	Description
31:0	Setting any bit in this register allows the corresponding interrupt signal to trigger a PCIE interrupt provided that the corresponding “Synchronous Interrupt Cause (H_INTR_SYNC_CAUS)” register bit is set. Note that for this register bit to be set, the corresponding “Synchronous Interrupt Enable (H_INTR_SYNC_ENAB)” register bit must also be set by software. See Table 7-13 for bit descriptions.

7.2.7.11 Asynchronous Interrupt Cause (H_INTR_ASYNC_CAUS)

Offset: 0x4038

Access: Read-Only

Reset Value: 0000_0000

Bit	Description
31:0	Setting any bit in this register indicates that the corresponding interrupt has been triggered in asynchronous mode. For any bit to be set in this register, the corresponding bit in the “Asynchronous Interrupt Enable (H_INTR_ASYNC_ENAB)” register must also be set. See Table 7-13 for bit descriptions.

7.2.7.12 Asynchronous Interrupt Enable (H_INTR_ASYN_ENAB)

Offset: 0x403C
Access: Read/Write
Reset Value: 0000_0002

Bit	Description
31:0	Setting any bit in this register indicates that the corresponding interrupt has been triggered in asynchronous mode. For any bit to be set in this register, the corresponding bit in the “Asynchronous Interrupt Enable (H_INTR_ASYN_ENAB)” register must also be set. See Table 7-13 for bit descriptions.

7.2.7.13 PCIE PHY RW (H_PHY_RW)

Offset: 0x4040
Access: Read/Write
Reset Value: 9248_FD00

Bit	Description
31:0	PCIE PHY data register

7.2.7.14 PCIE PHY Load (H_PHY_LOAD)

Offset: 0x4044
Access: Read/Write
Reset Value: 0000_0000

Bit	Description
31:0	PCIE PHY data load register

7.2.7.15 GPIO Input and Output (H_GPIO_IN_OUT)

Offset: 0x4048
Access: See field description
Reset Value: 000F_8C00

Bit	Access	Description
31:20	R/W	Reserved
19:20	RO	Actual value of each GPIO signal
9:0	R/W	Output value of each GPIO Used when the corresponding GPIO enable bits and GPIO output MUX registers are set correctly

7.2.7.16 GPIO Output Enable Bits (*H_GPIO_OE_BITS*)

Offset: 0x404C

Access: Read/Write

Reset Value: 0000_0000

NOTE: Each 2-bit field controls the drive mechanism for each GPIO. The mapping for this 2-bit field is:

- 0 = Input
- 1 = Drive if the corresponding output in GPIO_IN_OUT register is low, otherwise input.
- 2 = Drive if the corresponding output in GPIO_IN_OUT register is high, otherwise input.
- 3 = Drive value set in corresponding GPIO_IN_OUT register

Bit	Description
31:20	Reserved
19:18	Configuration for GPIO9
17:16	Configuration for GPIO8
15:14	Configuration for GPIO7
13:12	Configuration for GPIO6
11:10	Configuration for GPIO5
9:8	Configuration for GPIO4
7:6	Configuration for GPIO3
5:4	Configuration for GPIO2
3:2	Configuration for GPIO1
1:0	Configuration for GPIO0

7.2.7.17 GPIO Interrupt Polarity (*H_GPIO_IRQ_POLAR*)

Offset: 0x4050

Access: Read/Write

Reset Value: 0000_0000

Bit	Description	
31:10	Reserved	
9:0	GPIO interrupt polarity	
	0	Corresponding GPIO can interrupt if it is high
	1	Corresponding GPIO can interrupt system if it is low

7.2.7.18 GPIO Input Enable and Value (H_GP_INPT_EN_VAL)

Offset: 0x4054

Access: Read/Write

Reset Value: 0000_0000

Bit	Description	
31:18	Reserved	
17	0	JTAG enabled; GPIO[4:0] is controlled by JTAG controller
	1	JTAG disabled; software must set this bit before using GPIO[4:0]
16	0	RTC reset controlled entirely by software
	1	RTC reset controllable through a GPIO pin and software
15	0	Set RFSILENT_BB_L to default
	1	Connect RFSILENT_BB_L to a GPIO input
14	Reserved	
13	0	Set PCIE Attention Button to default
	1	Connect attention button to a GPIO input
12	0	Set BT_ACTIVE_ASYNC to default
	1	Connect BT_ACTIVE_ASYNC to a GPIO input
11	0	Set BT_FREQUENCY_ASYNC to default
	1	Connect BT_FREQUENCY_ASYNC to a GPIO input
10	0	Set BT_PRIORITY_ASYNC to default
	1	Connect BT_PRIORITY_ASYNC to a GPIO input
9:8	Reserved	
7	Default value of RFSILENT_BB_L input to the baseband	
6	Reserved	
5	Default value of PCIE attention button input	
4	Default value of BT_ACTIVE_ASYNC input	
3	Default value of BT_FREQUENCY_ASYNC input	
2	Default value of BT_PRIORITY_ASYNC input	
1:0	Reserved	

7.2.7.19 GPIO Input MUX1 (H_GP_INPT_MUX1)

Offset: 0x4058

Access: Read/Write

Reset Value: 0000_0000

Bit	Description
31:24	Reserved
23:20	GPIO_INPUT_MUX[5] for PCIE attention button input
19:16	GPIO_INPUT_MUX[4] for BT_ACTIVE_ASYNC input
15:12	GPIO_INPUT_MUX[3] for BT_FREQUENCY_ASYNC input
11:8	GPIO_INPUT_MUX[2] for BT_PRIORITY_ASYNC input
7:0	Reserved

7.2.7.20 GPIO Input MUX2 (H_GP_INPT_MUX2)

Offset: 0x405C

Access: Read/Write

Reset Value: 0000_E000

Bit	Description
31:12	Reserved
11:8	GPIO_INPUT_MUX[8] for RTC reset input
7:4	GPIO_INPUT_MUX[7] for RFSILENT_BB_1 input
3:0	Reserved

7.2.7.21 GPIO Output MUX1 (H_GP_OUTPT_MUX1)

Offset: 0x4060

Access: Read/Write

Reset Value: 0000_0000

NOTE: See Table 7-14.

Bit	Description
31:26	Reserved
29:25	GPIO_OUTPUT_MUX[5]
24:20	GPIO_OUTPUT_MUX[4]
19:15	GPIO_OUTPUT_MUX[3]
14:10	GPIO_OUTPUT_MUX[2]
9:5	GPIO_OUTPUT_MUX[1]
4:0	GPIO_OUTPUT_MUX[0]

7.2.7.22 GPIO Output MUX2 (H_GP_OUTPT_MUX2)

Offset: 0x4064

Access: Read/Write

Reset Value: 000E_8000

NOTE: See Table 7-14.

Bit	Description
31:20	Reserved
19:15	GPIO_OUTPUT_MUX[9]
14:10	GPIO_OUTPUT_MUX[8]
9:5	GPIO_OUTPUT_MUX[7]
4:0	GPIO_OUTPUT_MUX[6]

Table 7-14 shows the output MUX value for each GPIO.

Table 7-14. Output MUX Values for Each GPIO

Bit	Description
31	Set GPIO output to the value set in the GPIO output register
30	Reserved
29	Reserved
28	Set GPIO to RX_CLEAR_EXTENSION
27	Set GPIO to BT_ANT
26	Set GPIO to MAC_WOW signal
25:8	Reserved
7	Set GPIO to PCIE WAKE_L signal
6	Set GPIO to MAC power LED signal
5	Set GPIO to MAC network signal
4	Set GPIO to Rx-clear-external signal
3	Set GPIO to Tx-frame signal
2	Set GPIO to PCIE Power LED signal
1	Set GPIO output to PCIE Attention LED signal
0	Set GPIO output to value set in the GPIO output register

7.2.7.23 Input Values (H_INPUT_STATE)

Offset: 0x406C

Access: Read-Only

Reset Value: 0000_0013

Bit	Description
31:7	Reserved
6	Status of TX_FRAME from the MAC
5	Status of RX_CLEAR_EXTERNAL from the MAC
4	Status of the power LED from the MAC
3	Status of the network LED from the MAC
2	Status of PCIE_WAKE_L from PCIE core
1	Status of POWER_LED from PCIE core
0	Status of ATTENTION_LED from PCIE core

7.2.7.24 EEPROM Status and Read Data (H_EEP_STS_DATA)

Offset: 0x407C

Access: Read-Only

Reset Value: 0000_0000

Bit	Description
31:20	Reserved
19	This bit indicates that software attempted to access the EEPROM even though it is not present
18	This bit indicates that the last software access to the EEPROM occurred to a protected area within the EEPROM and was therefore not forwarded to the EEPROM
17	This bit indicates that the last software access to the EEPROM occurred when it was busy and was therefore not forwarded to the EEPROM
16	0 EEPROM is idle
	1 EEPROM is busy
15:0	Results of the last EEPROM read transfer

7.2.7.25 RFSilent-Related Registers (H_RFSILENT)

Offset: 0x4084

Access: Read/Write

Reset Value: 0000_0000

Bit	Description
31:3	Reserved
2	RTC reset invert This bit is only relevant if RTC reset override (bit [16]) in the “GPIO Input Enable and Value (H_GP_INPT_EN_VAL)” register is set. If the RTC reset override bit is cleared, then the RTC reset is entirely controlled by software (bit [0] of the register at 0x7040).
	0 A low in the corresponding GPIO input holds the RTC in reset; a high allows the RTC reset to be controlled by software
	1 A high in the corresponding GPIO input holds the RTC in reset; a low allows the RTC Reset to be controlled by software
1	RFSILENT_FORCE signal to the baseband
0	RFSilent polarity
	0 Do not invert the RFSILENT_BB_L signal to the baseband
	1 Invert the RFSILENT_BB_L signal to the baseband

7.2.7.26 GPIO Pull-Up/Pull-Down (H_GPIO_PDPU)

Offset: 0x4088
Access: Read/Write
Reset Value: 0000_0001

NOTE: Each 2-bit field controls the drive mechanism for each GPIO. The mapping for this 2-bit field is:

- 0 = No pull-up or pull-down
- 1 = Pull-down
- 2 = Pull-up
- 3 = Reserved

Bit	Description
31:20	Reserved
19:18	Configuration for GPIO9
17:16	Configuration for GPIO8
15:14	Configuration for GPIO7
13:12	Configuration for GPIO6
11:10	Configuration for GPIO5
9:8	Configuration for GPIO4
7:6	Configuration for GPIO3
5:4	Configuration for GPIO2
3:2	Configuration for GPIO1
1:0	Configuration for GPIO0

7.2.7.27 GPIO Drive Strength (H_GPIO_DS)

Offset: 0x408C
Access: Read/Write
Reset Value: 0000_0000

NOTE: Each 2-bit field corresponds to a particular value; the possibilities are:

- 0 = Default drive strength = 6 mA
- 1 = Drive strength = 12 mA
- 2 = Drive strength = 18 mA
- 3 = Drive strength = 24 mA

Bit	Description
31:20	Reserved
19:18	Configuration for GPIO9
17:16	Configuration for GPIO8
15:14	Configuration for GPIO7
13:12	Configuration for GPIO6
11:10	Configuration for GPIO5
9:8	Configuration for GPIO4
7:6	Configuration for GPIO3
5:4	Configuration for GPIO2
3:2	Configuration for GPIO1
1:0	Configuration for GPIO0

7.2.7.28 MSI Interrupt Enable (H_PCIE_MSI)

Offset: 0x4094

Access: Read/Write

Reset Value: 0000_0000

Bit	Description
31:9	Reserved
8:4	MSI interrupt vector This value is sent to the PCIE core whenever an interrupt is generated; it can be programmed to any value by software. Hardware defaults this value to zero.
3:1	Reserved
0	MSI interrupt enable Enable this bit for MSI interrupt functionality. This bit is self-cleared by the hardware once the interrupt request is passed to the PCIE core. Software reasserts this bit after the driver clears the source of the interrupt in the ISR.

7.2.7.29 Safe Mode Enable (H_SAFE_MODE_EN)

Offset: 0x4098

Access: Read/Write

Reset Value: 0000_0002

Bit	Description
31:1	Reserved
0	PCIE_STORE_N_FWD_ENABLE

7.2.8 RTC Interface Registers

RTC registers occupy the offset range 0x7000–0x7FFC in the AR9287 address space. Within this address range, the 0x7040–0x7058 registers are always on and available for software access regardless of whether the RTC is asleep. [Table 7-15](#) shows the mapping of these registers.

Table 7-15. RTC Interface Registers (Always On)

Offset	Name	Description	Page
0x7040	RTC_RESET	RTC Reset and Force Sleep and Force Wakeup	page 100
0x7044	RTC_STATUS	RTC Sleep Status	page 100
0x7048	RTC_DERIVED	RTC Force Derived RTC and Bypass Derived RTC	page 100
0x704C	RTC_FORCE_WAKE	RTC Force Wake	page 100
0x7050	RTC_INT_CAUSE	RTC Interrupt Cause	page 101
0x7050	RTC_CAUSE_CLR	RTC Interrupt Cause Clear	page 101
0x7054	RTC_INT_ENABLE	RTC Interrupt Enable	page 102
0x7058	RTC_INT_MASK	RTC Interrupt Mask	page 102

7.2.8.1 RTC Reset and Force Sleep and Force Wakeup (RTC_RESET)

Offset: 0x7040
Access: Read/Write
Default: 0

Bit	Description
31:1	Reserved
0	RTC reset (active low)

7.2.8.2 RTC Sleep Status (RTC_STATUS)

Offset: 0x7044
Access: Read-Only
Default: N/A

Bit	Description
31:6	Reserved
5	PLL_CHANGING signal from RTC
4	RTC cold reset (active high)
3	RTC in wakeup state
2	RTC in sleep state
1	RTC in on state
0	RTC in shutdown state

7.2.8.3 RTC Force Derived RTC and Bypass Derived RTC (RTC_DERIVED)

Offset: 0x7048
Access: Read/Write
Default: 0

Bit	Description
31:2	Reserved
1	Force derived RTC
0	Bypass derived RTC

7.2.8.4 RTC Force Wake (RTC_FORCE_WAKE)

Offset: 0x704C
Access: Read/Write
Default: 3

Bit	Description	
31:2	Reserved	
1	0	Do not assert FORCE_WAKE on MAC interrupt
	1	Assert FORCE_WAKE on MAC interrupt
0	FORCE_WAKE signal to the MAC	

7.2.8.5 RTC Interrupt Cause (RTC_INT_CAUSE)

Offset: 0x7050
Access: Read-Only
Default: 0

NOTE: The RTC Interrupt controller works the same way as the host interface interrupt controller. Each bit in this interrupt cause register pertains to an event as described.

Bit	Description
31:6	Reserved
5	PLL_CHANGING
4	Software access of an RTC register when it is not in the on state
3	RTC in wakeup state
2	RTC in sleep state
1	RTC in on state
0	RTC in shutdown state

7.2.8.6 RTC Interrupt Cause Clear (RTC_CAUSE_CLR)

Offset: 0x7050
Access: Write-Only
Default: 0

NOTE: A write of 1 to any bit in this register clears that bit in the “RTC Interrupt Cause (RTC_INT_CAUSE)” register until the corresponding event reoccurs.

Bit	Description
31:6	Reserved
5	Writing 1 to this bit clears the PLL_CHANGING interrupt from the “RTC Interrupt Cause (RTC_INT_CAUSE)” register.
4	Writing 1 to this bit clears the software access of an RTC register interrupt from the “RTC Interrupt Cause (RTC_INT_CAUSE)” register.
3	Writing 1 to this bit clears the RTC in wakeup state interrupt from the “RTC Interrupt Cause (RTC_INT_CAUSE)” register.
2	Writing 1 to this bit clears the RTC in sleep state interrupt from the “RTC Interrupt Cause (RTC_INT_CAUSE)” register.
1	Writing 1 to this bit clears the RTC in on state interrupt from the “RTC Interrupt Cause (RTC_INT_CAUSE)” register.
0	Writing 1 to this bit clears the RTC in shutdown state interrupt from the “RTC Interrupt Cause (RTC_INT_CAUSE)” register.

7.2.8.7 RTC Interrupt Enable (RTC_INT_ENABLE)

Offset: 0x7054
 Access: Read/Write
 Default: 0

NOTE: Writing a 1 to any bit in this register allows that bit in the “RTC Interrupt Cause (RTC_INT_CAUSE)” register to be set when the corresponding event occurs. Writing a 0 to any bit in this register automatically clears the corresponding bit in the interrupt cause register regardless of the corresponding event.

Bit	Description	
31:6	Reserved	
5	0	Clears the PLL_CHANGING bit in the “RTC Interrupt Cause (RTC_INT_CAUSE)”.
	1	Allows the PLL changing bit in the “RTC Interrupt Cause (RTC_INT_CAUSE)” to be set when the corresponding event occurs.
4	0	Clears the software access of an RTC register bit in the “RTC Interrupt Cause (RTC_INT_CAUSE)”.
	1	Allows the software access of an RTC register bit in the “RTC Interrupt Cause (RTC_INT_CAUSE)” to be set when the corresponding event occurs.
3	0	Clears the RTC in wakeup state bit in the “RTC Interrupt Cause (RTC_INT_CAUSE)”.
	1	Allows the RTC in wakeup state bit in the “RTC Interrupt Cause (RTC_INT_CAUSE)” to be set when the corresponding event occurs.
2	0	Clears the RTC in sleep state bit in the “RTC Interrupt Cause (RTC_INT_CAUSE)”.
	1	Allows the RTC in sleep state bit in the “RTC Interrupt Cause (RTC_INT_CAUSE)” to be set when the corresponding event occurs.
1	0	Clears the RTC in on state bit in the “RTC Interrupt Cause (RTC_INT_CAUSE)”.
	1	Allows the RTC in on state bit in the “RTC Interrupt Cause (RTC_INT_CAUSE)” to be set when the corresponding event occurs.
0	0	Clears the RTC in shutdown state bit in the “RTC Interrupt Cause (RTC_INT_CAUSE)”.
	1	Allows the RTC in shutdown state bit in the “RTC Interrupt Cause (RTC_INT_CAUSE)” to be set when the corresponding event occurs.

7.2.8.8 RTC Interrupt Mask (RTC_INT_MASK)

Offset: 0x7058
 Access: Read/Write
 Default: 0

NOTE: Writing a 1 to any bit in this register allows the corresponding event to generate an RTC interrupt to the host interface which can in turn be programmed to generate a system interrupt. The corresponding bit in the “RTC Interrupt Enable (RTC_INT_ENABLE)” register must also be set.

Bit	Description
31:6	Reserved
5	Writing 1 to this bit allows the corresponding PLL_CHANGING event to generate an RTC interrupt to the host interface.
4	Writing 1 to this bit allows the corresponding software access of an RTC register event to generate an RTC interrupt to the host interface.
3	Writing 1 to this bit allows the corresponding RTC in wakeup state event to generate an RTC interrupt to the host interface.
2	Writing 1 to this bit allows the corresponding RTC in sleep state event to generate an RTC interrupt to the host interface.
1	Writing 1 to this bit allows the corresponding RTC in on state event to generate an RTC interrupt to the host interface.
0	Writing 1 to this bit allows the corresponding RTC in shutdown state event to generate an RTC interrupt to the host interface.

7.2.9 MAC PCU Registers

Table 7-16 shows the mapping of these registers.

Table 7-16. MAC PCU Registers

Address	Name	Description	Page
0x8000	MAC_PCU_STA_ADDR_L32	STA Address Lower 32 Bits	page 105
0x8004	MAC_PCU_STA_ADDR_U16	STA Address Upper 16 Bits	page 105
0x8008	MAC_PCU_BSSID_L32	BSSID Lower 32 Bits	page 106
0x800C	MAC_PCU_BSSID_U16	BSSID Upper 16 Bits	page 106
0x8010	MAC_PCU_BCN_RSSI_AVE	Beacon RSSI Average	page 106
0x8014	MAC_PCU_ACK_CTS_TIMEOUT	ACK and CTS Timeout	page 106
0x8018	MAC_PCU_BCN_RSSI_CTL	Beacon RSSI Control	page 107
0x801C	MAC_PCU_USEC_LATENCY	Millisecond Counter and Rx/Tx Latency	page 107
0x8020	MAC_PCU_RESET_TSF	Reset TSF	page 107
0x8038	MAC_PCU_MAX_CFP_DUR	Maximum CFP Duration	page 108
0x803C	MAC_PCU_RX_FILTER	Rx Filter	page 108
0x8040	MAC_PCU_MCAST_FILTER_L32	Multicast Filter Mask Lower 32 Bits	page 108
0x8044	MAC_PCU_MCAST_FILTER_U32	Multicast Filter Mask Upper 32 Bits	page 109
0x8048	MAC_PCU_DIAG_SW	Diagnostic Switches	page 109
0x804C	MAC_PCU_TSF_L32	TSF Lower 32 Bits	page 110
0x8050	MAC_PCU_TSF_U32	TSF Upper 32 Bits	page 110
0x805C	MAC_PCU_AES_MUTE_MASK_0	AES Mute Mask 0	page 110
0x8060	MAC_PCU_AES_MUTE_MASK_1	AES Mute Mask 1	page 110
0x8080	MAC_PCU_LAST_BEACON_TSF	Last Receive Beacon TSF	page 110
0x8084	MAC_PCU_NAV	Current NAV	page 111
0x8088	MAC_PCU_RTS_SUCCESS_CNT	Successful RTS Count	page 111
0x808C	MAC_PCU_RTS_FAIL_CNT	Failed RTS Count	page 111
0x8090	MAC_PCU_ACK_FAIL_CNT	FAIL ACK Count	page 111
0x8094	MAC_PCU_FCS_FAIL_CNT	Failed FCS Count	page 112
0x8098	MAC_PCU_BEACON_CNT	Beacon Count	page 112
0x80D4	MAC_PCU_SLP1	Sleep 1	page 112
0x80D8	MAC_PCU_SLP2	Sleep 2	page 112
0x80E0	MAC_PCU_ADDR1_MASK_L32	Address 1 Mask Lower 32 Bits	page 113
0x80E4	MAC_PCU_ADDR1_MASK_U16	Address 1 Mask Upper 16 Bits	page 113
0x80E8	MAC_PCU_TPC	Tx Power Control	page 113
0x80EC	MAC_PCU_TX_FRAME_CNT	Tx Frame Counter	page 113
0x80F0	MAC_PCU_RX_FRAME_CNT	Rx Frame Counter	page 114
0x80F4	MAC_PCU_RX_CLEAR_CNT	Rx Clear Counter	page 114
0x80F8	MAC_PCU_CYCLE_CNT	Cycle Counter	page 114
0x80FC	MAC_PCU_QUIET_TIME_1	Quiet Time 1	page 114
0x8100	MAC_PCU_QUIET_TIME_2	Quiet Time 2	page 115

Table 7-16. MAC PCU Registers

Address	Name	Description	Page
0x8108	MAC_PCU_QOS_NO_ACK	QoS no ACK	page 115
0x810C	MAC_PCU_PHY_ERROR_MASK	PHY Error Mask	page 116
0x8114	MAC_PCU_RXBUF_THRESHOLD	Rx Buffer Threshold	page 116
0x8118	MAC_PCU_MIC_QOS_CONTROL	QoS Control	page 117
0x811C	MAC_PCU_MIC_QOS_SELECT	Michael QoS Select	page 117
0x8120	MAC_PCU_MISC_MODE	Miscellaneous Mode	page 118
0x8124	MAC_PCU_FILTER_OFDM_CNT	Filtered OFDM Counter	page 119
0x8128	MAC_PCU_FILTER_CCK_CNT	Filtered CCK Counter	page 119
0x812C	MAC_PCU_PHY_ERR_CNT_1	PHY Error Counter 1	page 119
0x8130	MAC_PCU_PHY_ERR_CNT_1_MASK	PHY Error Counter 1 Mask	page 120
0x8134	MAC_PCU_PHY_ERR_CNT_2	PHY Error Counter 2	page 120
0x8138	MAC_PCU_PHY_ERR_CNT_2_MASK	PHY Error Counter 2 Mask	page 120
0x813C	MAC_PCU_TSF_THRESHOLD	TSF Threshold	page 121
0x8144	MAC_PCU_PHY_ERROR EIFS_MASK	PHY Error EIFS Mask	page 121
0x8168	MAC_PCU_PHY_ERR_CNT_3	PHY Error Counter 3	page 121
0x816C	MAC_PCU_PHY_ERR_CNT_3_MASK	PHY Error Counter 3 Mask	page 121
0x8178	MAC_PCU_HCF_TIMEOUT	HCF Timeout	page 122
0x81D0	MAC_PCU_TXSIFS	SIFS, Tx Latency and ACK Shift	page 122
0x81EC	MAC_PCU_TXOP_X	TXOP for Non-QoS Frames	page 122
0x81F0	MAC_PCU_TXOP_0_3	TXOP for TID 0 to 3	page 123
0x81F4	MAC_PCU_TXOP_4_7	TXOP for TID 4 to 7	page 123
0x81F8	MAC_PCU_TXOP_8_11	TXOP for TID 8 to 11	page 123
0x81FC	MAC_PCU_TXOP_12_15	TXOP for TID 0 to 3	page 123
0x8200	MAC_PCU_GENERIC_TIMERS[0:15]	Generic Timers	page 124
0x8240	MAC_PCU_GENERIC_TIMERS_MODE	Generic Timers Mode	page 124
0x8244	MAC_PCU_SLP32_MODE	32 KHz Sleep Mode	page 124
0x8248	MAC_PCU_SLP32_WAKE	32 KHz Sleep Wake	page 125
0x824C	MAC_PCU_SLP32_INC	32 KHz Sleep Increment	page 125
0x8250	MAC_PCU_SLP_MIB1	Sleep MIB Sleep Count	page 125
0x8254	MAC_PCU_SLP_MIB2	Sleep MIB Cycle Count	page 125
0x8258	MAC_PCU_SLP_MIB3	Sleep MIB Control Status	page 126
0x8318	MAC_PCU_20_40_MODE	Global Mode	page 126
0x8328	MAC_PCU_RX_CLEAR_DIFF_CNT	Difference Rx_Clear Counter	page 126
0x8330	MAC_PCU_BA_BAR_CONTROL	Control Registers for Block BA Control Fields	page 127
0x8334	MAC_PCU_LEGACY_PLCP_SPOOF	Legacy PLCP Spoof	page 127
0x8338	MAC_PCU_PHY_ERROR_MASK_CONT	PHY Error Mask and EIFS Mask	page 127
0x833C	MAC_PCU_TX_TIMER	Tx Timer	page 128
0x8800	MAC_PCU_KEY_CACHE[0:1023]	Key Cache Lower Half	page 128

7.2.9.1 STA Address Lower 32 Bits (MAC_PCU_STA_ADDR_L32)

Offset: 0x8000

Access: Hardware = Read-Only
Software = Read/Write

Reset Value: 0x0

This register contains the lower 32 bits of the STA address.

Bit	Name	Description
31:0	ADDR_31_0	Lower 32 bits of STA MAC address (PCU_STA_ADDR[31:0])

7.2.9.2 STA Address Upper 16 Bits (MAC_PCU_STA_ADDR_U16)

Offset: 0x8004

Access: Hardware = Read-Only
Software = Read/Write

Reset Value: 0x2000_0000

This register contains the lower 32 bits of the STA address.

Bit	Name	Description	
31	REG_ADHOC_MCAST_SEARCH	Enables the key cache search for ad hoc MCAST packets	
30	PCU_CBCIV_ENDIAN	Endianness of IV in CBC nonce	
29	REG_PRESERVE_SEQNUM	Stops PCU from replacing the sequence number; must be set to 1	
28	PCU_KSRCH_MODE	Search key cache first. If not, match use offset for IV = 0, 1, 2, 3. <ul style="list-style-type: none"> ■ If KSRCH_MODE = 0 then do not search ■ If IV = 1, 2, or 3, then search ■ If IV = 0, do not search 	
27	REG_CRPT_MIC_ENABLE	Enables the checking and insertion of MIC in TKIP	
26	RES	Reserved	
25	PCU_BSRATE_11B	802.11b base rate	
		0	Use all rates
		1	Use only 1-2 Mbps
24	PCU_ACKCTS_6MB	Use 6 Mbps rate for ACK and CTS	
23:21	RES	Reserved	
20	PCU_PCF	Set if associated AP is PCF capable	
19	PCU_NO_KEYSEARCH	Disable key search	
18	PCU_PSMODE	Set if STA is in power-save mode	
17	PCU_ADHOC	Set if STA is in an ad hoc network	
16	PCU_AP	Set if STA is an AP	
15:0	PCU_STA_ADDR[47:32]	Upper 16 bits of station MAC address	

7.2.9.3 BSSID Lower 32 Bits (MAC_PCU_BSSID_L32)

Offset: 0x8008

Access: Hardware = Read/Write
Software = Read/Write

Reset Value: 0x0

This register contains the lower 32 bits of the BSS identification information.

Bit	Name	Description
31:0	PCU_BSSID[31:0]	Lower 32 bits of BSSID

7.2.9.4 BSSID Upper 16 Bits (MAC_PCU_BSSID_U16)

Offset: 0x800C

Access: Hardware = Read/Write
Software = Read/Write

Reset Value: 0x0

This register contains the upper 32 bits of the BSS identification information.

Bit	Name	Description
31:17	RES	Reserved
26:16	PCU_AID	Association ID
15:0	PCU_BSSID[47:32]	Upper 16 bits of BSSID

7.2.9.5 Beacon RSSI Average (MAC_PCU_BCN_RSSI_AVE)

Offset: 0x8010

Access: Hardware = Read/Write
Software = Read-Only

Reset Value: 0x800

Bit	Name	Description
31:12	RES	Reserved
11:0	REG_BCN_RSSI_AVE	Holds the average RSSI with 1/16 dB resolution. The RSSI is averaged over multiple beacons which matched our BSSID. AVE_VALUE is 12 bits with 4 bits below the normal 8 bits. These lowest 4 bits provide for a resolution of 1/16 dB. The averaging function is depends on the BCN_RSSI_WEIGHT; determines the ratio of weight given to the current RSSI value compared to the average accumulated value.

7.2.9.6 ACK and CTS Timeout (MAC_PCU_ACK_CTS_TIMEOUT)

Offset: 0x8014

Access: Hardware = Read-Only
Software = Read/Write

Reset Value: 0x0

Bit	Name	Description
31:30	RES	Reserved
29:16	PCU_CTS_TIMEOUT	Timeout while waiting for CTS (in cycles)
13:0	PCU_ACK_TIMEOUT	Timeout while waiting for ACK (in cycles)

7.2.9.7 Beacon RSSI Control (MAC_PCU_BCN_RSSI_CTL)

Offset: 0x8018

Access: Hardware = Read-Only

Software = Read/Write

Reset Value: 0x0

Bit	Name	Description
31:30	RES	Reserved
29	REG_BCN_RSSI_RST_STROBE	The BCN_RSSI_RESET clears "BCN_RSSI_AVE" to aid in changing channels
28:24	REG_BCN_RSSI_WEIGHT	Used to calculate "BCN_RSSI_AVE"
15:8	PCU_BCN_MISS_THR	Threshold at which the beacon miss interrupt asserts. Because the beacon miss counter increments at TBTT, it increments to 1 before the first beacon.
7:0	PCU_RSSI_THR	The threshold at which the beacon low RSSI interrupt is asserted when the average RSSI ("BCN_RSSI_AVE") below this level

7.2.9.8 Ms Counter and Rx/Tx Latency (MAC_PCU_USEC_LATENCY)

Offset: 0x801C

Access: Hardware = Read-Only

Software = Read/Write

Reset Value: 0x0

Bit	Name	Description
31:29	RES	Reserved
28:23	PCU_RXDELAY	Baseband Rx latency to start of SIGNAL (in μ s)
22:14	PCU_TXDELAY	Baseband Tx latency to start of timestamp in beacon frame (in μ s)
6:0	RES	Reserved

7.2.9.9 Reset TSF (MAC_PCU_RESET_TSF)

Offset: 0x8020

Access: Hardware = Read/Write

Software = Read/Write

Reset Value: 0x0

Controls beacon operation by the PCU.

Bit	Name	Description
31:25	RES	Reserved
24	ONE_SHOT	Setting this bit causes the TSF to reset. This register clears immediately after being reset.
23:0	RES	Reserved

7.2.9.10 Maximum CFP Duration (MAC_PCU_MAX_CFP_DUR)

Offset: 0x8038

Access: Hardware = Read-Only
Software = Read/Write

Contains the maximum time for a CFP.

Reset Value: 0x0

Bit	Name	Description
31:16	RES	Reserved
15:0	PCU_MAX_CFPDUR	Maximum contention free period duration (in μ s)

7.2.9.11 Rx Filter (MAC_PCU_RX_FILTER)

Offset: 0x803C

Access: Hardware = Read-Only
Software = Read/Write

Reset Value: 0x0

This register determines Rx frame filtering.

NOTE: If any bit is set, the corresponding packet types pass the filter and are DMAed. All filter conditions except the promiscuous setting rely on the no early PHY error and protocol version being checked to ensure it is version 0.

Bit	Name	Description
31:10	RES	Reserved
15	MCAST_BCAST_ALL	Enables receipt of all multicast and broadcast frames
14	PS_POLL	Enables receipt of PS-POLL
13:10	RES	Reserved
9	MY_BEACON	Retrieves any beacon frame with matching SSID
8	RES	Reserved
7	PROBE_REQ	Probe request enable. Enables reception of all probe request frames
6	RES	Reserved
5	PROMISCUOUS	Promiscuous receive enable; Enable reception of all frames, including errors
4	BEACON	Beacon frame enable; Enable reception of beacon frames.
3	CONTROL	Control frame enable; Enable reception of control frames
2	BROADCAST	Broadcast frame enable Enable reception of non beacon broadcast frames that originate from the BSS whose ID matches BSSID
1	MULTICAST	Multicast frame enable Enable reception of multicast frames that match the multicast filter
0	UNICAST	Unicast frame Enable Enable reception of unicast (directed) frames that match the STA address
	0	Disable. No ACK will return
	1	Enable

7.2.9.12 Multicast Filter Mask Lower 32 Bits (MAC_PCU_MCAST_FILTER_L32)

Offset: 0x8040

Access: Hardware = Read-Only
Software = Read/Write

This register contains the lower 32 bits of the multicast filter mask.

Reset Value: 0x0

Bit	Name	Description
31:0	PCU_MCAST_MASK	Multicast filter mask low. Lower 32 bits of multicast filter mask.

7.2.9.13 Multicast Filter Mask Upper 32 Bits (MAC_PCU_MCAST_FILTER_U32)

Offset: 0x8044

Access: Hardware = Read-Only
Software = Read/Write

Reset Value: 0x0

This register contains the upper 32 bits of the multicast filter mask.

Bit	Name	Description
31:0	PCU_MCAST_MASK	Multicast filter mask high. Upper 32 bits of multicast filter mask.

7.2.9.14 Diagnostic Switches (MAC_PCU_DIAG_SW)

Offset: 0x8048

Access: Hardware = Read-Only
Software = Read/Write

Reset Value: 0x0

Controls the operation of the PCU, including enabling/disabling acknowledgements, CTS, transmission, reception, encryption, loopback, FCS, channel information, and scrambler seeds.

Bit	Name	Description
31:30	RES	Reserved
29	RX_CLEAR_EXT_LOW	Force the RX_CLEAR_EXT signal to appear to the MAC as being low
28	RX_CLEAR_CTL_LOW	Force the RX_CLEAR_CTL signal to appear to the MAC as being low
27	RES	Reserved
26	SATURATE_CYCLE_CNT	The saturate cycle count bit, if set, causes the “ Cycle Counter (MAC_PCU_CYCLE_CNT) ” register to saturate instead of shifting to the right by 1 every time the count reaches 0xFFFFFFFF. This saturate condition also holds the rx_clear, rx_frame, and tx_frame counts.
25	FORCE_RX_ABORT	Force Rx abort bit in conjunction with Rx block aids quick channel change to shut down Rx. The force Rx abort bit kills with the Rx_abort any frame currently transferring between the MAC and baseband. while the RX block bit prevents any new frames from getting started.
24	RES	Reserved
23	PHYERR_ENABLE_EIFS_CTL	Uses framed and wait_wep in the pcu_rx_err logic if bits is set to 0
22	CHAN_IDLE_HIGH	Force channel idle high
21	IGNORE_NAV	Ignore virtual carrier sense (NAV)
20	RX_CLEAR_HIGH	Force RX_CLEAR high
19:18	RES	Reserved
17	ACCEPT_NON_V0	Enable or disable protocol field
16:8	RES	Reserved
7	CORRUPT_FCS	Enable or disable corrupt FCS. Enabling this bit causes an invalid FCS to be appended to a frame during transmission.
6	LOOP_BACK	Enable or disable Tx data loopback
5	HALT_RX	Enable or disable reception
4	NO_DECRYPT	Enable or disable decryption
3	NO_ENCRYPT	Enable or disable encryption
2	NO_CTS	Enable or disable CTS generation
1	NO_ACK	Enable or disable acknowledgement generation for all frames
0	PCU_INVALIDKEY_NOACK	Enable or disable acknowledgement when a valid key is not found for the received frames in the key cache.

7.2.9.15 TSF Lower 32 Bits (MAC_PCU_TSF_L32)

Offset: 0x804C

Access: Hardware = Read/Write
Software = Read/Write

Reset Value: 0xFFFFFFFF

Bit	Name	Description
31:0	VALUE	The timestamp value in μ s. Writes to this register do not cause the TSF to change. Rather, the value is held in a temporary staging area until this register is written, at which point both the lower and upper parts of the TSF are loaded. A read result of 0xFFFFFFFF indicates the read occurred before TSF logic woke. It may take up to 45 μ s after the chip is brought out of sleep for the TSF logic to wake.

7.2.9.16 TSF Upper 32 Bits (MAC_PCU_TSF_U32)

Offset: 0x8050

Access: Hardware = Read/Write
Software = Read/Write

Reset Value: 0xFFFFFFFF

Bit	Name	Description
31:0	VALUE	The timestamp value in μ s

7.2.9.17 AES Mute Mask 0 (MAC_PCU_AES_MUTE_MASK_0)

Offset: 0x805C

Access: Hardware = Read-Only
Software = Read/Write

Reset Value: 0xC7FF

Bit	Name	Description
31:16	QOS_MUTEMASK	AES mute mask for TID field
15:0	FC_MUTEMASK	AES mute mask for frame control field

7.2.9.18 AES Mute Mask 1 (MAC_PCU_AES_MUTE_MASK_1)

Offset: 0x8060

Access: Hardware = Read-Only
Software = Read/Write

Reset Value: 0x000F

Bit	Name	Description
31:16	FC_MGMT	AES mute mask for management frame control field
15:0	SEQ_MUTEMASK	AES mute mask for sequence number field

7.2.9.19 Last Rx Beacon TSF (MAC_PCU_LAST_BEACON_TSF)

Offset: 0x8080

Access: Hardware = Write-only
Software = Read-Only

Reset Value: 0x0

Bit	Name	Description
31:0	LAST_TSTP	Beacon timestamp. Lower 32 bits of timestamp of the last beacon received.

7.2.9.20 Current NAV (MAC_PCU_NAV)

Offset: 0x8084

Access: Hardware = Read/Write

Software = Read/Write

Reset Value: 0x0

Bit	Name	Description
31:26	RES	Reserved
25:0	CS_NAV	Current NAV value (in μ s)

7.2.9.21 Successful RTS Count (MAC_PCU_RTS_SUCCESS_CNT)

Offset: 0x8088

Access: Hardware = Read/Write

Software = Read-Only

Reset Value: 0x0

This register counts the number of successful RTS exchanges. The counter stops at 0xFFFF. After a read, automatically resets to 0.

Bit	Name	Description
31:16	RES	Reserved
15:0	RTS_OK	RTS/CTS exchange success counter

7.2.9.22 Failed RTS Count (MAC_PCU_RTS_FAIL_CNT)

Offset: 0x808C

Access: Hardware = Read/Write

Software = Read-Only

Reset Value: 0x0

This register counts the number of failed RTS exchanges. The counter stops at 0xFFFF. After a read, this register is automatically reset to 0.

Bit	Name	Description
31:16	RES	Reserved
15:0	RTS_FAIL	RTS/CTS exchange failure counter

7.2.9.23 FAIL ACK Count (MAC_PCU_ACK_FAIL_CNT)

Offset: 0x8090

Access: Hardware = Read/Write

Software = Read-Only

Reset Value: 0x0

This register counts the number of failed acknowledgements. The counter stops at 0xFFFF. After a read, this register is automatically reset to 0.

Bit	Name	Description
31:16	RES	Reserved
15:0	ACK_FAIL	DATA/ACK failure counter

7.2.9.24 Failed FCS Count (MAC_PCU_FCS_FAIL_CNT)

Offset: 0x8094

Access: Hardware = Read/Write
Software = Read-Only

Reset Value: 0x0

This register counts the number of failed frame check sequences. The counter stops at 0xFFFF. After a read, this register is automatically reset to 0.

Bit	Name	Description
31:16	RES	Reserved
15:0	FCS_FAIL	FCS failure counter

7.2.9.25 Beacon Count (MAC_PCU_BEACON_CNT)

Offset: 0x8098

Access: Hardware = Read/Write
Software = Read-Only

Reset Value: 0x0

This register counts the number of valid beacon frames received. The counter stops at 0xFFFF. After a read, automatically resets to 0.

Bit	Name	Description
31:16	RES	Reserved
15:0	BEACONCNT	Valid beacon counter

7.2.9.26 Sleep 1 (MAC_PCU_SLP1)

Offset: 0x80D4

Access: Hardware = Read/Write
Software = Read-Only

Reset Value: 0x0

The Sleep 1 register in conjunction with the "Sleep 2 (MAC_PCU_SLP2)" register, controls when the AR9287 should wake when waiting for AP Rx traffic. Sleep registers are only used when the AR9287 is in STA mode.

Bit	Name	Description
31:21	CAB_TIMEOUT	Time in TU that the PCU waits for CAB after receiving the beacon or the previous CAB, insuring that if no CAB is received after the beacon is received or if a long gap occurs between CABs, the CAB powersave state returns to idle.
20	RES	Reserved
19	ASSUME_DTIM	A mode bit which indicates whether to assume a beacon was missed when the SLP_BEACON_TIMEOUT occurs with no received beacons, in which case it assumes the DTIM was missed, and waits for CAB.
18:0	RES	Reserved

7.2.9.27 Sleep 2 (MAC_PCU_SLP2)

Offset: 0x80D8

Access: Hardware = Read/Write
Software = Read-Only

Reset Value: 0x0

Bit	Name	Description
31:21	BEACON_TIMEOUT	Time in TU that the PCU waits for a beacon after waking up. If this time expires, the PCU woke due to SLP_NEXT_DTIM, and SLP_ASSUME_DTIM is active, then it assumes the beacon was missed and goes directly to watching for CAB. Otherwise when this time expires, the beacon powersave state returns to idle.
20:0	RES	Reserved

7.2.9.28 Address 1 Mask Lower 32 Bits (MAC_PCU_ADDR1_MASK_L32)

Offset: 0x80E0

Access: Hardware = Read-Only
Software = Read/Write

Reset Value: 0xFFFFFFFF

This STA register provides multiple BSSID support when the AR9287 is in AP mode.

Bit	Name	Description
31:0	STA_MASK_L	STA address mask lower 32-bit register. Provides multiple BSSID support.

7.2.9.29 Address 1 Mask Upper 16 Bits (MAC_PCU_ADDR1_MASK_U16)

Offset: 0x80E4

Access: Hardware = Read-Only
Software = Read/Write

Reset Value: 0xFFFF

This STA register provides multiple BSSID support when the AR9287 is in AP mode.

Bit	Name	Description
31:0	STA_MASK_L	STA address mask upper 16-bit register. Provides multiple BSSID support.

7.2.9.30 Tx Power Control (MAC_PCU_TPC)

Offset: 0x80E8

Access: Hardware = Read-Only
Software = Read/Write

Reset Value: 0x003F_3F3F

This register set the transmit power for self-generated response frames.

Bit	Name	Description
31:22	RES	Reserved
21:16	CHIRP_PWR	Chirp self-generated response frames
15:14	RES	Reserved
13:8	CTS_PWR	CTS self-generated response frames
7:6	RES	Reserved
5:0	ACK_PWR	ACK self-generated response frames

7.2.9.31 Tx Frame Counter (MAC_PCU_TX_FRAME_CNT)

Offset: 0x80EC

Access: Hardware = Read/Write
Software = Read/Write

Reset Value: 0x0

The Tx frame counter counts the number of cycles the tx_frame signal is active.

Bit	Name	Description
31:0	TX_FRAME_CNT	Counts the number of cycles the tx_frame signal is active

7.2.9.32 Rx Frame Counter (MAC_PCU_RX_FRAME_CNT)

Offset: 0x80F0

Access: Hardware = Read/Write
Software = Read/Write

Reset Value: 0x0

The receive frame counter counts the number of cycles the rx_frame signal is active.

Bit	Name	Description
31:0	RX_FRAME_CNT	Counts the number of cycles the rx_frame signal is active

7.2.9.33 Rx Clear Counter (MAC_PCU_RX_CLEAR_CNT)

Offset: 0x80F4

Access: Hardware = Read/Write
Software = Read/Write

Reset Value: 0x0

The receive clear counter counts the number of cycles the rx_clear signal is not active.

Bit	Name	Description
31:0	RX_CLEAR_CNT	Counts the number of cycles the rx_clear signal is low

7.2.9.34 Cycle Counter (MAC_PCU_CYCLE_CNT)

Offset: 0x80F8

Access: Hardware = Read/Write
Software = Read/Write

Reset Value: 0x0

The cycle counter counts the number of clock cycles.

Bit	Name	Description
31:0	CYCLE_CNT	Counts the number of clock cycles

7.2.9.35 Quiet Time 1 (MAC_PCU_QUIET_TIME_1)

Offset: 0x80FC

Access: Hardware = Read-Only
Software = Read/Write

Reset Value: 0x0

The Quiet Time registers implement the quiet time function specified in the proposed 802.11h extension supporting radar detection.

Bit	Name	Description
31:18	RES	Reserved
17	QUIET_ACK_CTS_ENABLE	If set, then the MAC sends an ACK or CTS in response to a received frame
16:0	RES	Reserved

7.2.9.36 Quiet Time 2 (MAC_PCU_QUIET_TIME_2)

Offset: 0x80FC

Access: Hardware = Read-Only
Software = Read/Write

Reset Value: 0x0

The Quiet Time registers implement the quiet time function specified in the proposed 802.11h extension supporting radar detection.

NOTE: QUIET_ENABLE is implemented as GENERIC_TIMER_ENABLE and NEXT_QUIET as GENERIC_TIMER_NEXT. QUIET_PERIOD is implemented as GENERIC_TIMER_PERIOD.

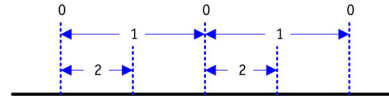

- 0 = NEXT_QUIET = TSF[31:0]
 - 1 = QUIET_PERIOD
 - 2 = QUIET_DURATION
- (Chip remains awake during QUIET_DURATION)*

Bit	Name	Description
31:16	QUIET_DURATION	The length of time in TUs that the chip is required to be quiet
15:0	RES	Reserved

7.2.9.37 QoS No ACK (MAC_PCU_QOS_NO_ACK)

Offset: 0x8108

Access: Hardware = Read-Only
Software = Read/Write

Reset Value: 0x52

This register provides a mechanism to locate the NoACK information in the QoS field and determine which encoding means NOACK.

Bit	Name	Description	
31:9	RES	Reserved	
8:7	NOACK_BYTE_OFFSET	Number of bytes from the byte after end of the header of a data packet to the byte location where No Ack information is stored. (The end of the header is at byte offset 25 for 3-address packets and 31 for 4-address packets.)	
6:4	NOACK_BIT_OFFSET	Offsets from the byte where the No Ack information should be stored; offset can range from 0 to 6 only	
3:0	NOACK_2_BIT_VALUES	These values are of a two bit field that indicate No ACK	
		NOACK_2_BIT_VALUE	Encoding Matching No ACK
		xxx1	00
		xx1x	01
		x1xx	10
1xxx	11		

7.2.9.38 PHY Error Mask (MAC_PCU_PHY_ERROR_MASK)

Offset: 0x810C

Access: Hardware = Read-Only

Software = Read/Write

Reset Value: 0x2

NOTE: Provides the ability to choose which PHY errors from the baseband to filter. The error number offsets into this register. If the mask value at the offset is 0, this error filters and does not show up on the Rx queue.

Bit	Name	Description
31	ERROR CCK RESTART	CCK restart error
30	ERROR CCK SERVICE	CCK service error
29:28	RES	Reserved
27	ERROR CCK RATE_ILLEGAL	CCK illegal rate error
26	ERROR CCK HEADER_CRC	CCK CRC header error
25	ERROR CCK TIMING	False detection for CCK
24	RES	Reserved
23	ERROR OFDM RESTART	OFDM restart error
22	ERROR OFDM SERVICE	OFDM service error
21	ERROR OFDM POWER_DROP	OFDM power drop error
20	ERROR OFDM LENGTH_ILLEGAL	OFDM illegal length error
19	ERROR OFDM RATE_ILLEGAL	OFDM illegal rate error
18	ERROR OFDM SIGNAL_PARITY	OFDM signal parity error
17	ERROR OFDM TIMING	False detection for OFDM
16:8	RES	Reserved
7	ERROR TX_INTERRUPT_RX	Transmit interrupt
6	ERROR ABORT	Abort error
5	ERROR RADAR_DETECT	Radar detect error
4	ERROR PANIC	Panic error
3:1	RES	Reserved
0	ERROR TRANSMIT_UNDERRUN	Transmit underrun error

7.2.9.39 Rx Buffer Threshold (MAC_PCU_RXBUF_THRESHOLD)

Offset: 0x8114

Access: Hardware = Read-Only

Software = Read/Write

Reset Value: 0x400

Bit	Name	Description
31:11	RES	Reserved
10:0	RXBUF_THRSHD	When the number of valid entries in the Rx buffer is larger than this threshold, host interface logic gives higher priority to the Rx side to prevent Rx buffer overflow.

7.2.9.40 QoS Control (MAC_PCU_MIC_QOS_CONTROL)

Offset: 0x8118

Access: Hardware = Read-Only

Software = Read/Write

Reset Value: 0xAA

Bit	Name	Description	
31:17	RES	Reserved	
16	MIC_QOS_ENABLE	Enable MIC QOS control	
		0	Disable hardware Michael
		1	Enable hardware Michael
15:14	MIC_QOS_CONTROL [7]	MIC QOS control [7]. See options for " MIC_QOS_CONTROL [0] ".	
13:12	MIC_QOS_CONTROL [6]	MIC QOS control [6]. See options for " MIC_QOS_CONTROL [0] ".	
11:10	MIC_QOS_CONTROL [5]	MIC QOS control [5]. See options for " MIC_QOS_CONTROL [0] ".	
9:8	MIC_QOS_CONTROL [4]	MIC QOS control [4]. See options for " MIC_QOS_CONTROL [0] ".	
7:6	MIC_QOS_CONTROL [3]	MIC QOS control [3]. See options for " MIC_QOS_CONTROL [0] ".	
5:4	MIC_QOS_CONTROL [2]	MIC QOS control [2]. See options for " MIC_QOS_CONTROL [0] ".	
3:2	MIC_QOS_CONTROL [1]	MIC QOS control [1]. See options for " MIC_QOS_CONTROL [0] ".	
1:0	MIC_QOS_CONTROL [0]	MIC QOS control [0]	
		0	Use 0 when calculating Michael
		1	Use 1 when calculating Michael
		2	Use MIC_QOS_SELECT when calculating Michael
		3	Use inverse of MIC_QOS_SELECT when calculating Michael

7.2.9.41 Michael QoS Select (MAC_PCU_MIC_QOS_SELECT)

Offset: 0x811C

Access: Hardware = Read-Only

Software = Read/Write

Reset Value: 0x3210

Bit	Name	Description
31:28	MIC_QOS_SELECT [7]	MIC QOS select [7]. Select the OOS TID bit when calculating Michael.
27:24	MIC_QOS_SELECT [6]	MIC QOS select [6]. Select the OOS TID bit when calculating Michael.
23:20	MIC_QOS_SELECT [5]	MIC QOS select [5]. Select the OOS TID bit when calculating Michael.
19:16	MIC_QOS_SELECT [4]	MIC QOS select [4]. Select the OOS TID bit when calculating Michael.
15:12	MIC_QOS_SELECT [3]	MIC QOS select [3]. Select the OOS TID bit when calculating Michael.
11:8	MIC_QOS_SELECT [2]	MIC QOS select [2]. Select the OOS TID bit when calculating Michael.
7:4	MIC_QOS_SELECT [1]	MIC QOS select [1]. Select the OOS TID bit when calculating Michael.
3:0	MIC_QOS_SELECT [0]	MIC QOS select [0]. Select the OOS TID bit when calculating Michael.

7.2.9.42 Miscellaneous Mode (MAC_PCU_MISC_MODE)

Offset: 0x8120

Access: Hardware = Read-Only

Software = Read/Write

Reset Value: 0x8F24800

Bit	Name	Description
31:29	RES	Reserved
28	ALWAYS_PERFORM_KEY_SEARCH	If this bit is set, key search is performed for every frame in an aggregate. If this bit is cleared, key search is only performed for the first frame of an aggregate. Unless the transmitter address is different between the frames in an aggregate. This bit has no effect on non-aggregate frame packets.
27	SEL_EVM	If the SEL_EVM bit is set, the evm field of the Rx descriptor status contains the EVM data received from the baseband. If this bit is cleared, the evm field of the Rx descriptor status contains 3 bytes of Legacy PLCP, 2 service bytes, and 6 bytes of HP PLCP.
26	CLEAR_BA_VALID	If the CLEAR_BA_VALID bit is set, the state of the block ACK storage is invalidated.
25	CLEAR_FIRST_HCF	If the CLEAR_FIRST_HCF bit is set, then the first_hcf state will be cleared. Set this bit to enter fast channel change mode and clear the bit once fast channel change is over.
24	CLEAR_VMF	If the CLEAR_VMF bit is set, then the VMF mode in the transmit state machine will be cleared. Set this bit to enter fast channel change mode and clear it once fast channel change is over.
23	RX_HCF_POLL_ENABLE	If the RX_HCF_POLL_ENABLE bit is set, then the MAC is enabled to receive directed HCF polls. If this bit is not set the receive state machine does not tell the rest of the MAC that it has received a directed HCF poll.
22	HCF_POLL_CANCELS_NAV	If the HCF_POLL_CANCELS_NAV bit is set when a directed HCF poll is received, the current NAV is cancelled and HCF data burst can proceed at SIFS.
21	TBTT_PROTECT	If the TBTT_PROTECT bit is set, then the time from TBTT to 20 μ s after TBTT is protected from transmit. Turn this off in ad hoc mode or if this MAC is used in the AP.
20:19	RES	Reserved
18	FORCE_QUIET_COLLISION	If the FORCE_QUIET_COLLISION bit is set, the PCU thinks that it is in quiet collision period, kills any transmit frame in progress, and prevents any new frame from starting.
17:13	RES	Reserved
12	TXOP_TBTT_LIMIT_ENABLE	If this limit is set, then logic to limit the value of the duration to fit the time remaining in TXOP and time remaining until TBTT is turned on. This logic will also filter frames, which will exceed TXOP.
11:5	RES	Reserved
4	CCK_SIFS_MODE	If the CCK_SIFS_MODE is set, the chip assumes that it is using 802.11g mode where SIFS is set to 10 μ s and non-CCK frames must add 6 to SIFS to make it CCK frames. This bit is needed in the duration calculation, which also needs the SIFS_TIME register.
3	TX_ADD_TSF	If the TX_ADD_TSF bit is set, the TSF in the transmit packet will be added to the internal TSF value for transmit beacons and prob_response frames.
2	MIC_NEW_LOCATION_ENABLE	If MIC_NEW_LOCATION_ENABLE is set, the Tx Michael Key is assumed to be co-located in the same entry that the Rx Michael key is located.
1	RES	Reserved
0	BSSID_MATCH_FORCE	If the BSSID_MATCH_FORCE bit is set, all logic based on matching the BSSID thinks that the BSSID matches.

7.2.9.43 Filtered OFDM Counter (MAC_PCU_FILTER_OFDM_CNT)

Offset: 0x8124

Access: Hardware = Read/Write

Software = Read/Write

Reset Value: 0x0

The filtered OFDM counters use the MIB control signals.

Bit	Name	Description
31:24	RES	Reserved
23:0	FILTOFDM_CNT	Counts the OFDM frames that were filtered using MIB control signals. The MIB freeze register holds all the values of these registers, and MIB zeros out all the values of these registers. PIB MIB forces incrementation of all registers in each cycle. This counter saturates at the highest value and is writable. If the upper two bits of these counters are b11, PCU_MIB_THRESHOLD is asserted and an interrupt generated.

7.2.9.44 Filtered CCK Counter (MAC_PCU_Filter_CCK_CNT)

Offset: 0x8128

Access: Hardware = Read/Write

Software = Read/Write

Reset Value: 0x0

Bit	Name	Description
31:24	RES	Reserved
23:0	FILTCKK_CNT	Counts the CCK frames that were filtered using MIB control signals. The MIB freeze register holds all the values of these registers, and MIB zeros out all the values of these registers. PIB MIB forces incrementation of all registers in each cycle. This counter saturates at the highest value and is writable. If the upper two bits of these counters are b11, PCU_MIB_THRESHOLD is asserted and an interrupt generated.

7.2.9.45 PHY Error Counter 1 (MAC_PCU_PHY_ERR_CNT_1)

Offset: 0x812C

Access: Hardware = Read/Write

Software = Read/Write

Reset Value: 0x0

The PHY error counters count any PHY error matching the respective mask. The bits of 32-bit

masks correspond to the first 32 encoded values of the error. Setting multiple bits in the mask provides an ORing function to provide flexibility in counting. For example, if setting the mask bits to 0xFF0000FF, then all PHY errors from 0–7 and 24–31 are counted.

Bit	Name	Description
31:24	RES	Reserved
23:0	PHY_ERROR_CNT1	Counts any PHY error1 using MIB control signals. The MIB freeze register holds all the values of these registers, and MIB zeros out all the values of these registers. PIB MIB forces incrementation of all registers in each cycle. Counter saturates at the highest value and is writable. If the upper two counter bits are b11, PCU_MIB_THRESHOLD is asserted and an interrupt generated.

7.2.9.46 PHY Error Counter 1 Mask (MAC_PCU_PHY_ERR_CNT_1_MASK)

Offset: 0x8130

Access: Hardware = Read-Only
Software = Read/Write

Reset Value: 0x0

Bit	Name	Description
31:0	PHY_ERROR_CNT_MASK1	Counts any error that matches the PHY error1 mask. The values of any 32-bit masks correspond to the first 32 encoded values of the error. Setting multiple bits in the mask provides an ORing function to allow counting flexibility (e.g., setting the mask to 0xFF0000FF means all PHY errors from 0:7 and 24:31 are counted).

7.2.9.47 PHY Error Counter 2 (MAC_PCU_PHY_ERR_CNT_2)

Offset: 0x8134

Access: Hardware = Read-Only
Software = Read/Write

Reset Value: 0x0

Bit	Name	Description
31:24	RES	Reserved
23:0	PHY_ERROR_CNT	Counts any error that matches the PHY error2 mask. The values of any 32-bit masks correspond to the first 32 encoded values of the error. Setting multiple bits in the mask provides an ORing function to allow counting flexibility (e.g., setting the mask to 0xFF0000FF means all PHY errors from 0:7 and 24:31 are counted).

7.2.9.48 PHY Error Counter 2 Mask (MAC_PCU_PHY_ERR_CNT_2_MASK)

Offset: 0x8138

Access: Hardware = Read-Only
Software = Read/Write

Reset Value: 0x0

Bit	Name	Description
31:0	PHY_ERROR_CNT_MASK2	Counts any PHY error2 using MIB control signals. The MIB freeze register holds all the values of these registers, and MIB zeros out all the values of these registers. PIB MIB forces incrementation of all registers in each cycle. This counter saturates at the highest value and is writable. If the upper two bits of these counters are b11, PCU_MIB_THRESHOLD is asserted and an interrupt generated.

7.2.9.49 TSF Threshold (MAC_PCU_TSF_THRESHOLD)

Offset: 0x813C

Access: Hardware = Read-Only
Software = Read/Write

Reset Value: 0x0

Bit	Name	Description
31:16	RES	Reserved
15:0	TSF_THRESHOLD	Asserts the PCU_TSF_OUT_OF_RANGE_INTER if the corrected receive TSF in a beacon is different from the internal TSF by more than this threshold.

7.2.9.50 PHY Error EIFS Mask (MAC_PCU_PHY_ERROR{EIFS_MASK)

Offset: 0x8144

Access: Hardware = Read-Only
Software = Read/Write

Reset Value: 0x0

Bit	Name	Description
31:0	VALUE	This mask provides the ability to choose which PHY errors from the baseband cause EIFS delay. The error number is used as an offset into this mask. If the mask value at the offset is 1, then this error will not cause EIFS delay.

7.2.9.51 PHY Error Counter 3 (MAC_PCU_PHY_ERR_CNT_3)

Offset: 0x8168

Access: Hardware = Read-Only
Software = Read/Write

Reset Value: 0x0

Bit	Name	Description
31:24	RES	Reserved
23:0	PHY_ERROR_CNT3	Count of PHY errors that pass the PHY_ERR_CNT_3_MASK filter

7.2.9.52 PHY Error Counter 3 Mask (MAC_PCU_PHY_ERR_CNT_3_MASK)

Offset: 0x816C

Access: Hardware = Read-Only
Software = Read/Write

Reset Value: 0x0

Bit	Name	Description
31:0	PHY_ERROR_CNT_MASK3	Mask of the PHY error number allowed to be counted

7.2.9.53 HCF Timeout (MAC_PCU_HCF_TIMEOUT)

Offset: 0x8178

Access: Hardware = Read-Only
Software = Read/Write

Reset Value: 0x0

Bit	Name	Description
31:16	RES	Reserved
15:0	VALUE	The time the PCU waits after the HCF trigger timer occurs before the PCU returns to sleep mode, unless the HCF poll has been detected. An interrupt is generated if the timeout occurs before a HCF poll is detected.

7.2.9.54 SIFS, Tx Latency and ACK Shift (MAC_PCU_TXSIFS)

Offset: 0x81D0

Access: Hardware = Read-Only
Software = Read/Write

Reset Value: 0x0

Bit	Name	Description
31:15	RES	Reserved
14:12	ACK_SHIFT	ACK_SHIFT is used to generate the ACK_TIME, which is used to generate the ACK_SIFS_TIME. The ACK_TIME table in the hardware assumes a channel width of 2.5 MHz. This value should be 3 for CCK rates.
		0 2.5 MHz
		1 5 MHz
11:8	TX_LATENCY	TX_LATENCY is the latency in μ s from tx_frame being asserted by the MAC to when the energy of the frame is on the air. This value is used to decrease the time to TBTT and time remaining in TXOP in the calculation to determine quiet collision.
7:0	SIFS_TIME	SIFS_TIME is the number of μ s in SIFS. This value is used to determine quiet collision and filtering due to TBTT and TXOP limits.

7.2.9.55 TxOP for Non-QoS Frames (MAC_PCU_TXOP_X)

Offset: 0x81EC

Access: Hardware = Read-Only
Software = Read/Write

Reset Value: 0x0

Bit	Name	Description
31:8	RES	Reserved
7:0	SIFS_TIME	TXOP in units of 32 μ s. A TXOP value exists for each QoS TID value. When a new burst starts, the TID is used to select one of the 16 TXOP values. This TXOP decrements until the end of the burst to make sure that the packets are not sent out by the time TXOP expires. TXOPX is used for legacy non QoS bursting.

7.2.9.56 TxOP for TID 0 to 3 (MAC_PCU_TXOP_0_3)

Offset: 0x81F0

Access: Hardware = Read-Only
Software = Read/Write

Reset Value: 0x0

Bit	Name	Description
31:24	VALUE_3	Value in units of 32 μ s
23:16	VALUE_2	Value in units of 32 μ s
15:8	VALUE_1	Value in units of 32 μ s
7:0	VALUE_0	Value in units of 32 μ s

7.2.9.57 TXOP for TID 4 to 7 (MAC_PCU_TXOP_4_7)

Offset: 0x81F4

Access: Hardware = Read-Only
Software = Read/Write

Reset Value: 0x0

Bit	Name	Description
31:24	VALUE_7	Value in units of 32 μ s
23:16	VALUE_6	Value in units of 32 μ s
15:8	VALUE_5	Value in units of 32 μ s
7:0	VALUE_4	Value in units of 32 μ s

7.2.9.58 TXOP for TID 8 to 11 (MAC_PCU_TXOP_8_11)

Offset: 0x81F8

Access: Hardware = Read-Only
Software = Read/Write

Reset Value: 0x0

Bit	Name	Description
31:24	VALUE_11	Value in units of 32 μ s
23:16	VALUE_10	Value in units of 32 μ s
15:8	VALUE_9	Value in units of 32 μ s
7:0	VALUE_8	Value in units of 32 μ s

7.2.9.59 TXOP for TID 0 to 3 (MAC_PCU_TXOP_12_15)

Offset: 0x81FC

Access: Hardware = Read-Only
Software = Read/Write

Reset Value: 0x0

Bit	Name	Description
31:24	VALUE_15	Value in units of 32 μ s
23:16	VALUE_14	Value in units of 32 μ s
15:8	VALUE_13	Value in units of 32 μ s
7:0	VALUE_12	Value in units of 32 μ s

7.2.9.60 Generic Timers (MAC_PCU_GENERIC_TIMERS[0:15])

Offset: 0x8200

Access: Hardware = Read/Write
Software = Read/Write

Reset Value: 0x0

Address	Default	Description
0x8200–0x821C	0x0	GENERIC_TIMER_NEXT
0x8220–0x823C	0x0	GENERIC_TIMER_PERIOD

NOTE: GENERIC_TIMER_0, unlike other generic timers, does not wake the MAC before timer expiration and its overflow mechanism does not generate an interrupt. Instead, it silently adds this period repeatedly until the next timer advances past the TSF. Thus when MAC wakes after sleeping for multiple TBTTs, the TGBTT does not assert repeatedly or cause the beacon miss count to jump.

Generic Timer	Function
0	TBTT
1	DMA beacon alert
2	SW beacon alert
3	HCF trigger timer
4	NEXT_TIM
5	NEXT_DTIM
6	Quiet time trigger
7	No dedicated function

7.2.9.61 Generic Timers Mode (MAC_PCU_GENERIC_TIMERS_MODE)

Offset: 0x8240

Access: Hardware = Read/Write
Software = Read/Write

Reset Value: 0x00100000

Bit	Name	Description
31:11	THRESH	Number of μ s that generate a threshold interrupt if exceeded in TSF comparison
10:8	OVERFLOW_INDEX	Indicates the last generic timer that overflowed
7:0	ENABLE	

7.2.9.62 32 KHz Sleep Mode (MAC_PCU_SLP32_MODE)

Offset: 0x8244

Access: Hardware = Read-Only
Software = Read/Write

Reset Value: See field description

Bit	Name	Description
31:23	RES	Reserved
22	DISABLE_32KHZ	Indicates the 32 KHz clock is not used to control the TSF, but the MAC clock increments the TSF. Only used on AP class devices that do not go to sleep. Reset Value: 0x0
21	TSF_WRITE_STATUS	The TSF write status. Reset Value: 0x1
20	ENABLE	When set, indicates that the TSF should be allowed to increment on its own. Reset Value: 0x1
19:0	HALF_CLK_LATENCY	Time in μ s from the detection of the falling edge of the 32 KHz clk to the rising edge of the 32 KHz clk. Reset Value: 0xF424

7.2.9.63 32 KHz Sleep Wake (MAC_PCU_SLP32_WAKE)

Offset: 0x8248

Access: Hardware = Read-Only
Software = Read/Write

Reset Value: 0x800

Bit	Name	Description
15:0	XTL_TIME	Time in μ s before a generic timer should expire that the wake signal asserts to the crystal wake logic. Add an extra 31 μ s due to 32 KHz clock resolution.

7.2.9.64 32 KHz Sleep Increment (MAC_PCU_SLP32_INC)

Offset: 0x824C

Access: Hardware = Read-Only
Software = Read/Write

Reset Value: 0x1E848

Bit	Name	Description
31:20	RES	Reserved
19:0	TSF_INC	Time in $1/2^{12}$ of a μ s the TSF increments on the rising edge of the 32 KHz clk (30.5176 μ s period). The upper 8 bits are at μ s resolution. The lower 12 bits are the fractional portion. $\frac{1 \text{ unit}}{1/2^{12} \text{ ms}} = \frac{X}{30.5176 \text{ ms}}$ Where X = 125000, or 0x1E848 is the default setting for 32.768 MHz clock.

7.2.9.65 Sleep MIB Sleep Count (MAC_PCU_SLP_MIB1)

Offset: 0x8250

Access: Hardware = Read/Write
Software = Read/Write

Reset Value: 0x0

Bit	Name	Description
31:0	SLEEP_CNT	Counts the number of 32 KHz clock cycles that the MAC has been asleep

7.2.9.66 Sleep MIB Cycle Count (MAC_PCU_SLP_MIB2)

Offset: 0x8254

Access: Hardware = Read/Write
Software = Read/Write

Reset Value: 0x0

Bit	Name	Description
31:0	CYCLE_CNT	Counts the absolute number of 32KHz clock cycles. When CYCLE_CNT bit 31 is 1, the MIB interrupt will be asserted. SLEEP_CNT and CYCLE_CNT are saturating counters when the value of CYCLE_CNT reaches 0xFFFF_FFFF both counters will stop incrementing.

7.2.9.67 Sleep MIB Control Status (MAC_PCU_SLP_MIB3)

Offset: 0x8258

Access: Hardware = Read/Write

Software = Read/Write

Reset Value: 0x0

Bit	Name	Description
31:2	RES	Reserved
1	PENDING	SLEEP_CNT, CYCLE_CNT, and CLR_CNT are writable for diagnostic purposes. Before every read/write, the pending bit should be polled to verify any pending write has cleared.
0	CLR_CNT	CLR_CNT clears both SLEEP_CNT and CYCLE_CNT. Pending is asserted while the clearing of these registers is pending.

7.2.9.68 Global Mode (MAC_PCU_20_40_MODE)

Offset: 0x8318

Access: Hardware = Read-Only

Software = Read/Write

Reset Value: 0x0

Bit	Name	Description
31:1	RES	Reserved
0	JOINED_RX_CLEAR	Setting this bit causes the rx_clear used in the MAC to be the AND of the control channel rx_clear and the extension channel rx_clear. If this bit is clear then the MAC will use only the control channel rx_clear.

7.2.9.69 Difference Rx_Clear Counter (MAC_PCU_RX_CLEAR_DIFF_CNT)

Offset: 0x8328

Access: Hardware = Read-Only

Software = Read/Write

Reset Value: 0x0

Bit	Name	Description
31:0	RX_CLEAR_DIFF_CNT	A cycle counter MIB register. On every cycle of the MAC clock, this counter increments every time the extension channel rx_clear is low when the MAC is not actively transmitting or receiving. Due to a small lag between tx_frame and rx_clear as well as between rx_clear and rx_frame, the count may have some residual value even when no activity is on the extension channel.

7.2.9.70 Control Registers for Block BA Control Fields (MAC_PCU_BA_BAR_CONTROL)

Offset: 0x8330

Access: Hardware = Read-Only
Software = Read/Write

Reset Value: See field description

Bit	Name	Description
31:10	RES	Reserved
9	ACK_POLICY_VALUE	The value of the ACK policy bit. Reset Value: 0x1
8	COMPRESSED_VALUE	The value of the compressed bit. Reset Value: 0x1
7:4	ACK_POLICY_OFFSET	Indicates the bit offset in the block ACK or block ACK request control field which defines the location of the ACK policy bit. Reset Value: 0x0
3:0	COMPRESSED_OFFSET	Indicates the bit offset in the block ACK or block ACK request control field which defines the location of the COMPRESSED bit. Reset Value: 0x2

7.2.9.71 Legacy PLCP Spoof (MAC_PCU_LEGACY_PLCP_SPOOF)

Offset: 0x8334

Access: Hardware = Read-Only
Software = Read/Write

Reset Value: See field description

Bit	Name	Description
31:9	RES	Reserved
12:8	MIN_LENGTH	This register defines the minimum spoofed legacy PLCP length. Reset Value: 0xE
7:0	EIFS_MINUS_DIFS	Defines the number of μ s to be subtracted from the transmit packet duration to provide fairness for legacy devices as well as HT devices. Reset Value: 0x0

7.2.9.72 PHY Error Mask and EIFS Mask (MAC_PCU_PHY_ERROR_MASK_CONT)

Offset: 0x8338

Access: Hardware = Read-Only
Software = Read/Write

Reset Value: 0x0

Bit	Name	Description
31:19	RES	Reserved
23:16	EIFS_VALUE	Continuation of register MAC_PCU_PHY_ERROR_MASK_VALUE. Bits [2], [1], and [0] correspond to PHY errors 34, 33, and 32. All others PHY errors above 39 cause EIFS delay.
15:8	RES	Reserved
7:0	MASK_VALUE	Continuation of register MAC_PCU_PHY_ERROR_MASK_VALUE. Bits [2], [1], and [0] correspond to PHY errors 34, 33, and 32. All others PHY errors above 39 will be filtered.

7.2.9.73 Tx Timer (MAC_PCU_TX_TIMER)

Offset: 0x833C

Access: Hardware = Read/Write

Software = Read/Write

Reset Value: 0x0

Bit	Name	Description
31:16	RES	Reserved
15	TX_TIMER_ENABLE	Enabled when this bit is set to 1.
14:0	TX_TIMER	Guarantees the transmit frame does not take more time than the values programmed in this timer. The unit for this timer is in μ s.

7.2.9.74 Key Cache (MAC_PCU_KEY_CACHE[0:1023])

Offset: 0x8800

Access: Hardware = Read-Only

Software = Read/Write

Reset Value: 0x0

Table 7-17. Offset to First Dword of Nth Key [1]

Intra Key	Offset Bits	Description	
$8*N + 00$	31:0	Key[31:0]	
$8*N + 04$	15:0	Key[47:32]	
$8*N + 08$	31:0	Key[79:48]	
$8*N + 0C$	15:0	Key[95:79]	
$8*N + 10$	31:0	Key[127:96]	
$8*N + 14$	2:0	Key type:	
		0	40b
		1	104b
		2	TKIP without MIC
		3	128b
		4	TKIP
		5	Reserved
		6	AES_CCM
$8*N + 14$	14:3	Reserved	
$8*N + 18$	31:0	Addr[32:1]	
$8*N + 1C$	14:0	Addr[47:33]	
	15	Key valid	
	17:16	Key ID	

[1]Key = (PCIE Address: 8800 + 20*N)

When the key type is 4 (TKIP) and key is valid, this entry + 64 contains the Michael key.

Table 7-18. Offset to First Dword of Nth Key (continued)

Intra Key	Offset Bits	Description
$8*N + 800$	31:0	Rx Michael key 0
$8*N + 804$	15:0	Tx Michael key 0 [31:16]
$8*N + 808$	31:0	Rx Michael key 1
$8*N + 80C$	15:0	Tx Michael key 0 [15:0]
$8*N + 810$	31:0	Tx Michael key 1
$8*N + 814$	RES	Reserved
$8*N + 818$	RES	Reserved
$8*N + 81C$	RES	Reserved
	15	Key Valid = 0

TKIP keys are not allowed to reside in the entries 64–127 because they require the Michael key. Entries 64–67 are always reserved for Michael.

NOTE: Internally this memory is 50 bits wide, thus to write a line of the memory requires two 32-bit writes. All writes to registers with an offset of 0x0 or 0x8 actually write to a temporary holding register. A write to register with an offset of 0x4 or 0xC writes to the memory with the current write value concatenated with the temporary holding register.

7.2.10 Wake-on-Wireless Register

The WoW registers occupy the offset range 0x825C–0x8294 in the AR9287 address space.

Table 7-19. AR9287 WoW Registers

Offset	Name	Description	Page
0x825C	WOW_CONTRL_STATUS	WoW Control and Status	page 129
0x8260	WOW_AIFS_CNT	AIFS Time	page 130
0x8278	KEEP_ALIVE_TIMEOUT	KEEP_ALIVE_TIMEOUT for Automatically Sending Keep-Alive Frames	page 130
0x827C	AUTO_KEEP_ALIVE	Disable Automatic Keep-Alive Frame Generation	page 130
0x8284	US_SCALAR	Microsecond Scalar of the MAC Clock	page 131
0x8288	KEEP_ALIVE_DELAY	Delay Between Keep-Alive Frames	page 131
0x828C	PATTERN_MATCH_CONTROL	Enable End of Packet and Offset Check for Each Pattern	page 131
0x8290	PATTERN_OFFSET1	Byte Offsets for Patterns 0–3	page 132
0x8294	PATTERN_OFFSET2	Byte Offsets for Patterns 4–7	page 132
0xE000–0xEFFC	TRANSMIT_BUFFER	Buffer for Keep-Alive Frames and WoW Patterns	page 132

7.2.10.1 WoW Control and Status (WOW_CONTROL_STATUS)

Offset: 0x825C

Access: Read/Write

Reset: See field description

Bit	Name	Reset	Description
31:28	BACK_OFF_SHIFT	0x4	Maximum backoff time The backoff time in μ s is given by the equation: Maximum backoff time = $(1 \ll \text{BACKOFF_SHIFT}) - 1$
27:20	RES	0	Reserved
19	KEEP_ALIVE_FAIL	N/A	Keep-alive fail status Indicates that no ACK was received for a transmitted keep-alive frame. In this case, this bit will be set even if software sets the “Keep-Alive Timeout (KEEP_ALIVE_TIMEOUT)” register. This bit will be cleared when software sets the WOW_PME_CLEAR bit in the “Host Power Management Control (H_PM_CTRL)” register.
18	MAC_INTR_ENABLE	0	Enable MAC Interrupts to generate WoW When set, the AR9287 can send a WoW signal if the MAC asserts its interrupt. The MAC must be appropriately programmed to generate an interrupt.
17	MAGIC_PACKET_FOUND	N/A	Magic packet detect field Indicates that a magic packet has been received. This bit will be cleared when software sets the WOW_PME_CLEAR bit in the “Host Power Management Control (H_PM_CTRL)” register.
16	MAGIC_ENABLE	0	Enable magic pattern from the AP to generate WoW If set, the AR9287 can send a WoW signal if the AP sends a magic packet.
15:8	WOW_PATTERN_FOUND	N/A	Each bit in this field indicates that the corresponding pattern has been received by the AR9287. The bit will be cleared when software sets the WOW_PME_CLEAR bit in the “Host Power Management Control (H_PM_CTRL)” register.
7:0	PATTERN_MATCH_ENABLE	0	Enable a pattern from the AP to generate WoW If any of these bits are set, the AR9287 can send a WoW signal if the AP sends a packet that matches the corresponding pattern.

7.2.10.2 AIFS Wait Period (WOW_AIFS_CNT)

Offset: 0x8260

Access: Read/Write

Reset Value: See field description

Bit	Name	Reset	Description
31:24	RES	0	Reserved
23:16	KEEP_ALIVE_CNT	0x8	Keep-alive attempt count Number of times the AR9287 attempts to send keep-alive frames before giving up and sending the WoW signal to the host.
15:8	WOW_SLOT_CNT	0x9	Slot wait period Determines slot wait period before the AR9287 sends keep-alive frames.
7:0	WOW_AIFS_CNT	0x22	AIFS time Determines AIFS wait period before the AR9287 sends keep-alive frames. The value is expressed in μ s.

7.2.10.3 Keep-Alive Timeout (KEEP_ALIVE_TIMEOUT)

Offset: 0x8278

Access: Read/Write

Reset Value: 0x03E4180

Bit	Name	Description
31:0	KEEP_ALIVE_TIMEOUT	Keep alive timeout for automatically sending keep-alive frames Number of reference clocks (32 KHz) for which the AR9287 will wait before sending a pair of keep-alive frames. This value is relevant only if the "Auto Keep Alive Disable (AUTO_KEEP_ALIVE_DISABLE)" register is cleared. The AR9287 will also automatically send a keep-alive frame when it gets a beacon from the AP.

7.2.10.4 Auto Keep Alive Disable (AUTO_KEEP_ALIVE_DISABLE)

Offset: 0x827C

Access: Read/Write

Reset Value: 0

Bit	Name	Description
31:2	RES	Reserved
1	KEEP_ALIVE_FAIL_DISABLE	Disable WoW generation if no ACK is received for a transmitted keep-alive frame 0 Generate a WoW event if no ACK is received for a transmitted keep-alive frame 1 Do not generate a WoW event if no ACK is received for a transmitted keep-alive frame
0	AUTO_KEEP_ALIVE_DISABLE	Disable automatic keep-alive frame generation 0 Send keep-alive frames automatically when the KEEP_ALIVE_TIMEOUT bit in the "Keep-Alive Timeout (KEEP_ALIVE_TIMEOUT)" register expires 1 Do not send keep-alive frames automatically (only send in response to a beacon)

7.2.10.5 US Scalar (US_SCALAR)

Offset: 0x8284
 Access: Read/Write
 Reset Value: 0x2C

Bit	Name	Description		
31:7	RES	Reserved		
6:0	US_SCALAR	μ s scalar of the MAC clock Scalar value for generating 1 μ s pulses based on the MAC clock.		
		2.4 GHz	HT20 mode	Clock runs at 44 MHz
			HT40 mode	Clock runs at 88 MHz

7.2.10.6 Keep-Alive Frame Delay (KEEP_ALIVE_DELAY)

Offset: 0x8288
 Access: Read/Write
 Reset Value: 0x2C

Bit	Name	Description
31:12	RES	Reserved
11:0	KEEP_ALIVE_DELAY	Delay between keep-alive frames (in μ s) The first keep-alive frame has the PM bit cleared, while the second has the PM bit set.

7.2.10.7 End of Packet and Offset Check Enables for Each of the Eight Patterns (PATTERN_MATCH_CONTROL)

Offset: 0x828C
 Access: Read/Write
 Reset Value: 0

Bit	Name	Description
31:16	RES	Reserved
15:8	PATTERN_OFFSET_MCH	Flag to check for a byte offset before starting pattern match checking Setting one of these bits set causes the AR9287 to start pattern match checking at the programmed byte offset for the corresponding pattern. If these bits are cleared then the AR9287 ignores byte offsets while match checking for the corresponding pattern. Therefore the 256 byte pattern can start anywhere within the incoming packet.
7:0	PATTERN_END_OF_PKT	Flag to check for end-of-packet after a pattern match to generate WoW Setting one of these bits causes the AR9287 to check for the end-of-packet condition after all 256 bytes of the corresponding pattern have been matched. If the end-of-packet condition does not occur after pattern matching with a bit set for any particular pattern, then the AR9287 does not generate a WoW signal based on this pattern. If these bits are cleared, the AR9287 does not check for the end-of-packet condition. It does generate a WoW signal after the 256 byte pattern has been matched regardless of whether it is at the end of the incoming packet.

7.2.10.8 Byte Offsets for Patterns 0–3 (PATTERN_OFFSET1)

Offset: 0x8290
Access: Read/Write
Reset Value: 0

Bit	Name	Description	
31:0	PATTERN_OFFSET1	Only relevant if the corresponding bits in the “End of Packet and Offset Check Enables for Each of the Eight Patterns (PATTERN_MATCH_CONTROL)” register are set. The bit fields are:	
		Bits [31:24]	Byte offset for pattern 3
		Bits [23:16]	Byte offset for pattern 2
		Bits [15:8]	Byte offset for pattern 1
		Bits [7:0]	Byte offset for pattern 0

7.2.10.9 Byte Offsets for Patterns 4–7 (PATTERN_OFFSET2)

Offset: 0x8294
Access: Read/Write
Reset Value: 0

Bit	Name	Description	
31:0	PATTERN_OFFSET2	Only relevant if the corresponding bits in the “End of Packet and Offset Check Enables for Each of the Eight Patterns (PATTERN_MATCH_CONTROL)” register are set. The bit fields are:	
		Bits [31:24]	Byte offset for pattern 7
		Bits [23:16]	Byte offset for pattern 6
		Bits [15:8]	Byte offset for pattern 5
		Bits [7:0]	Byte offset for pattern 4

7.2.10.10 Transmit Buffer (TRANSMIT_BUFFER)

Offset: 0xE000–0xEFFC
Access: Read/Write
Reset Value: N/A

Bit	Name	Description
31:0	TRANSMIT_BUFFER	Transmit buffer for storing keep-alive frames and pattern matching frames.

8. Electrical Characteristics

8.1 Absolute Maximum Ratings

Table 8-1 summarizes the absolute maximum ratings and Table 8-2 lists the recommended operating conditions for the AR9287.

Absolute maximum ratings are those values beyond which damage to the device can occur. Functional operation under these conditions or at any other condition beyond those indicated in the operational sections of this document is not recommended.

Table 8-1. Absolute Maximum Ratings

Symbol	Parameter	Max Rating	Unit
V_{dd12}	Supply Voltage	-0.3 to 1.8	V
V_{dd33}	Maximum I/O Supply Voltage	-0.3 to 4.0	V
RF_{in}	Maximum RF Input (Reference to 50 Ω)	+10	dBm
T_{store}	Storage Temperature	-60 to 150	$^{\circ}\text{C}$
T_j	Junction Temperature	125	$^{\circ}\text{C}$
ESD	Electrostatic Discharge Tolerance	2000	V
	Electrostatic Discharge Tolerance (XTALO, XTALI, PDET0, and PDET1 pins)	1000	V

8.2 Recommended Operating Conditions

Table 8-2. Recommended Operating Conditions

Symbol	Parameter	Conditions	Min	Typ	Max	Unit
V_{dd12}	Supply Voltage ^[1]	$\pm 5\%$	1.19	1.25	1.31	V
V_{dd33}	I/O Voltage	$\pm 10\%$	2.97	3.3	3.63	V
T_{case}	Case Temperature	—	0	—	110	$^{\circ}\text{C}$
Ψ_{siJT}	Thermal Parameter ^[2]	—	—	—	2.5	$^{\circ}\text{C}/\text{W}$

[1]Since the 1.25 V supply is derived from 3.3 V, the AR9287 expects that 1.25 V lags 3.3 V.

[2]For 9x9 mm LPCC package.

8.3 40 MHz Clock Characteristics

When using an external clock, the XTALI pin is grounded and the XTALO pin should be driven with a square wave clock.

The DC voltage level of XTALO should be approximately 0.6 V. The external clock driving XTALO must have sharp rise and fall times to reduce jitter.

Table 8-3. 40 MHz Clock Characteristics

Symbol	Parameter	Conditions	Min	Typ	Max	Unit
V _{IH}	Input High Voltage	—	1	—	3.3	V
V _{IL}	Input Low Voltage	—	-0.2	—	0.2	V
T _{DCycle}	Duty Cycle	—	40	50	60	%
T _{Rise}	Clock Rise Time	—	—	—	2	ns
T _{Fall}	Clock Fall Time	—	—	—	2	ns

8.4 GPIO DC Electrical Characteristics

Table 8-4 lists the GPIO DC electrical characteristics, with:

$$V_{dd} = 3.3 \text{ V}, T_{amb} = 25 \text{ }^{\circ}\text{C}$$

Table 8-4. General DC Electrical Characteristics

Symbol	Parameter	Conditions	Min	Typ	Max	Unit
V _{IH}	High Level Input Voltage	—	0.7 * V _{dd}	—	—	V
V _{IL}	Low Level Input Voltage	—	—	—	0.3 * V _{dd}	V
V _{OH}	High Level Output Voltage	—	0.9 * V _{dd}	—	—	V
V _{OL}	Low Level Output Voltage	—	—	—	0.1 * V _{dd}	V

8.5 PCIE Pin Characteristics

Table 8-5 shows the AR9287 PCI Express interface pin characteristics.

Table 8-5. PCI Express Interface Pin Characteristics:

Signal Name	Pin	Type	Drive	PU/PD Resistance
PCI Express Bus Interface Characteristics				
RST_L	2	IH	—	100 K Ω PU
PCIE_RST_L	32	I	—	—
PCIE_WAKE_L	16	OD	24 mA	—
PCIE_CLKREQ_L	27	OD	24 mA	—
PCIE_REFCLK_N	30	IA	—	—
PCIE_REFCLK_P	31	IA	—	—
PCIE_TX_N	33	OA	—	—
PCIE_TX_P	34	OA	—	—
PCIE_RX_N	35	IA	—	—
PCIE_RX_P	36	IA	—	—
GPIO Interface Characteristics				
GPIO_0 to GPIO_9 (see “GPIO Drive Strength (H_GPIO_DS)” on page 98)	21, 18, 15, 13, 22, 23, 24, 26, 40, 41	I/O	up to 24 mA	250 K Ω PD

8.6 Power Up Sequencing

Figure 8-1 depicts the required reset sequence for the AR9287 PCI Express interface.

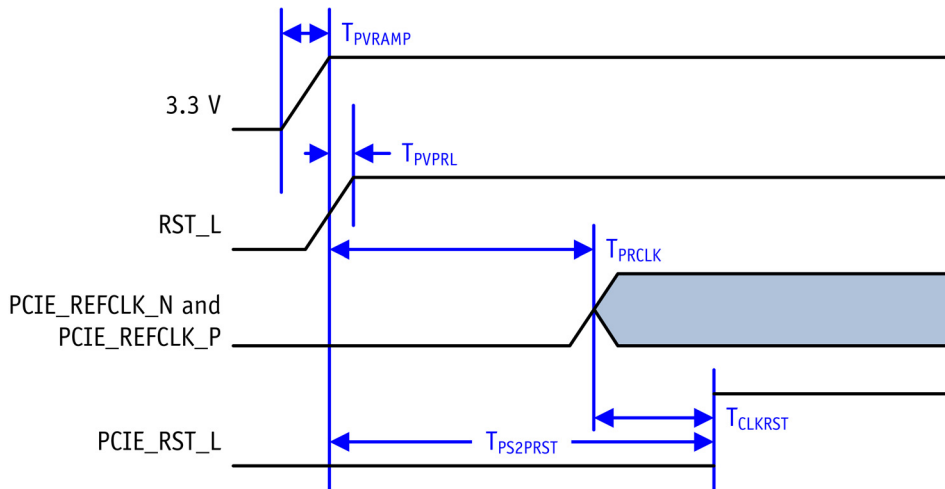

Figure 8-1. Power Up Sequencing

Table 8-6 shows the AR9287 PCI Express interface timing parameters.

Table 8-6. PCI Express Interface Timing Parameter

Signal Name	Description	Min	Max
T_{PVRAMP}	Power Supply Ramp on 3.3V	—	1 ms
T_{PVPRL}	Power valid to RST_L asserted	0 μ s ^[1]	—
T_{PRCLK}	RST_L de-asserted to PCIE_REFCLK_N and PCIE_REFCLK_P stable	100 μ s	—
T_{CLKRST}	PCIE_REFCLK_N and PCIE_REFCLK_P stable to PCIE_RST_L de-asserted	100 μ s ^[2]	—
$T_{PS2PRST}$	Power supply stable to PCIE_RST_L de-assert	10 ms	—

[1]It is recommended to leave the RST_L pin floating. At power up, internal power-on reset signal derived from 1.25 V and 3.3 V supply will ensure correct functionality.

[2]This timing depends on hardware interface designs, such as Express Card, PCIE Mini Card, or PCIE desktop applications. The system must follow PCI Express specification, as well as T_{CLKRST} .

8.7 EEPROM Timing Specifications

Figure 8-2 defines the timing parameters for the EEPROM interface.

Table 8-7. EEPROM Timing Specifications

Symbol	Parameter	Min	Max	Unit
T_{sck}	EPRM_SCK Cycle Time	4	—	μs
T_{high}	High Time of EPRM_SCK (Parameter Scales with T_{sck})	$0.35 * T_{sck}$	$0.40 * T_{sck}$	μs
T_{w_val}	Write Data Valid from Falling Edge EPRM_SCK (Parameter Scales with T_{sck})	$0.10 * T_{sck}$	$0.15 * T_{sck}$	μs
T_{r_su}	Read Data Setup Time to Rising Edge of EPRM_SCK	50	—	ns
T_{r_h}	Read Data Hold Time from Rising Edge of EPRM_SCK	50	—	ns

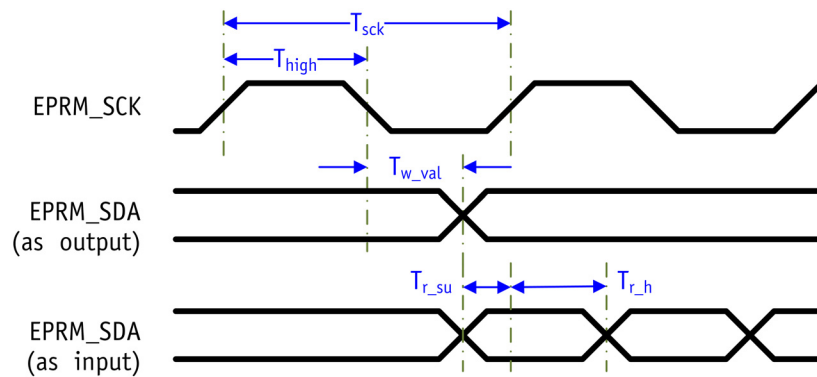

Figure 8-2. EEPROM Interface Timing

8.8 Radio Characteristics

The following conditions apply unless otherwise specified:

$$V_{dd12} = 1.25 \text{ V}$$

$$V_{dd33} = 3.3 \text{ V}, T_{amb} = 25 \text{ }^\circ\text{C}$$

8.8.1 Receiver Characteristics

Table 8-8 summarizes the AR9287 receiver characteristics.

Table 8-8. Receiver Characteristics for 2.4 GHz Operation

Symbol	Parameter	Conditions	Min	Typ	Max	Unit
F_{RX}	Receive input center frequency	5 MHz steps	2.412	—	2.472	GHz
NF	Receive chain noise figure (max gain, LNA1)	See Note [1]	—	7	—	dB
S_{rf}	Sensitivity (LNA1)					
	CCK, 1 Mbps	See Note [2]	-80	-94	—	dBm
	CCK, 11 Mbps		-76	-89	—	
	OFDM, 6 Mbps		-82	-92	—	
	OFDM, 54 Mbps	—	-65	-77	—	—
	HT20, MCS0	See Note [2]	-82	-92	—	dBm
	HT20, MCS7		-64	-73	—	
	HT20, MCS8		-82	-91	—	
	HT20, MCS15		-64	-71	—	
	HT40, MCS0	See Note [2]	-79	-88	—	dBm
	HT40, MCS7		-61	-71	—	
	HT40, MCS8		-79	-87	—	
	HT40, MCS15		-61	-67	—	
	IP1dB	Input 1 dB compression (min. gain)	—	—	-7	—
IIP3	Input third intercept point (min. gain)	—	—	3	—	dBm
Z_{RFIn_input}	Recommended LNA differential drive impedance	Ch 0, Ch 1	—	$12+j17^{[3]}$	—	Ω
ER_{phase}	I,Q phase error	—	—	$1^{[4]}$	—	$^\circ$
ER_{amp}	I,Q amplitude error	—	—	$0.1^{[4]}$	—	dB
R_{adj}	Adjacent channel rejection					
	OFDM, 6 Mbps	10 to 20 MHz [5]	16	33	—	dB
	OFDM, 54 Mbps		-1	19	—	
	HT20, MCS0	10 to 20 MHz [5]	16	32	—	dB
	HT20, MCS7		-2	17	—	
	HT20, MCS8		16	32	—	
HT20, MCS15	-2		16	—		
TR_{powup}	Time for power up (from synthesizer on)	—	—	1.5	—	μs

[1]For improved sensitivity performance, an external LNA may be used.

[2]Sensitivity performance based on Atheros reference design, which includes integrated Tx/Rx antenna switch. Minimum values based on IEEE 802.11 specifications.

[3]Estimated value.

[4]IQ Phase Error and IQ Amplitude Error are analog values prior to digital correction.

[5]Typical values measured with reference design. Minimum values based on IEEE 802.11 specifications.

8.8.2 Transmitter Characteristics

Table 8-9 summarizes the transmitter characteristics for the AR9287.

Table 8-9. Transmitter Characteristics for 2.4 GHz Operation

Symbol	Parameter	Conditions	Min	Typ	Max	Unit	
F_{tx}	Transmit output center frequency	5 MHz steps	2.412	—	2.472	GHz	
P_{out}	Mask Compliant CCK output power	See Note [1]	—	21	—	dBm	
	EVM Compliant OFDM output power for 64 QAM		—	14	—		
	HT20, MCS15		—	12	—	dBm	
	HT40, MCS15		—	11	—		
SP_{gain}	PA gain step	See Note [2]	—	0.5	—	dB	
A_{pl}	Power Accuracy	See Note [3]	—	± 1.5	—	dB	
Z_{RFout_load}	Recommended PA differential load impedance	Ch 0, Ch 1 See Note [4]	—	$12+j17$	—	Ω	
OP1dB	Output P1dB (max. gain)	2.442 GHz	—	16	—	dBm	
OIP3	Output third order intercept point (max. gain)	2.442 GHz	—	25	—	dBm	
SS	Sideband suppression	—	—	-41	—	dBc	
RS	Synthesizer reference spur:	—	—	-70	—	dBc	
Tx_{mask}	Transmit spectral mask						
	OFDM	At 11 MHz offset	See Note [5]	—	-23	-20	dBr
		At 20 MHz offset		—	-34	-28	
		At 30 MHz offset		—	-52	-40	
	HT20	At 11 MHz offset	See Note [5]	—	-22	-20	dBr
		At 20 MHz offset		—	-31	-28	
		At 30 MHz offset		—	-49	-40	
	HT40	At 21 MHz offset	See Note [5]	—	-22	-20	dBr
		At 40 MHz offset		—	-30	-28	
At 60 MHz offset		—		-48	-45		
TTpowup	Time for power up (from synthesizer on)	—	—	1.5	—	μs	

[1] Combined output power of both chains as measured on Atheros reference design.

[2] Guaranteed by design.

[3] Manufacturing calibration required.

[4] See the impedance matching circuit in the Atheros reference design schematics. To achieve good RF performance, it is strongly recommended not to alter the RF portion of the Atheros reference design for different matching networks.

[5] Measured at the antenna connector port. Average conducted transmit power levels = 18 dBm for OFDM, HT20, and 16.5 dBm for HT40. System includes internal PA. Maximum permissible values based on IEEE 802.11 specifications.

8.8.3 Synthesizer Characteristics

Table 8-10 summarizes the synthesizer characteristics for the AR9287.

Table 8-10. Synthesizer Composite Characteristics for 2.4 GHz Operation

Symbol	Parameter	Conditions	Min	Typ	Max	Unit
P _n	Phase noise (at Tx_Out)	—	—	—	—	dBc/Hz
	At 30 KHz offset					
	At 100 KHz offset					
	At 500 KHz offset					
	At 1 MHz offset					
F _C	Channel center frequency	Center frequency at 5 MHz spacing ^[1]	2.412	—	2.472	GHz
F _{ref}	Reference oscillator frequency	± 20 ppm ^[2]	—	40	—	MHz
T _{S_{powup}}	Time for power up	—	—	250	—	μs

[1]Frequency is measured at the Tx output.

[2]Over temperature variation and aging.

8.9 Power Consumption Parameters

The following conditions apply unless otherwise specified:

$$V_{dd12} = 1.25 \text{ V}$$

$$V_{dd33} = 3.3 \text{ V}, T_{amb} = 25 \text{ }^{\circ}\text{C}$$

Table 8-11 shows the typical power drain on each of the two on-chip power supply domains as a function of the AR9287's operating mode.

Table 8-11. Power Consumption for 2.4 GHz Operation

Operating Mode	3.3 V Supply (mA)	1.25 V Supply (mA)
Sleep	4	6
Idle (Two-chain Rx)	70	290
Tx (Two-chain) ^[1]	520	215
Rx (Two-chain)	80	330

[1]Value includes internal PA, transmit power = 16dBm.

9. Package Dimensions

The AR9287 9x9 76-pin LPCC package drawings and dimensions are provided in Figure 9-1 and Table 9-1.

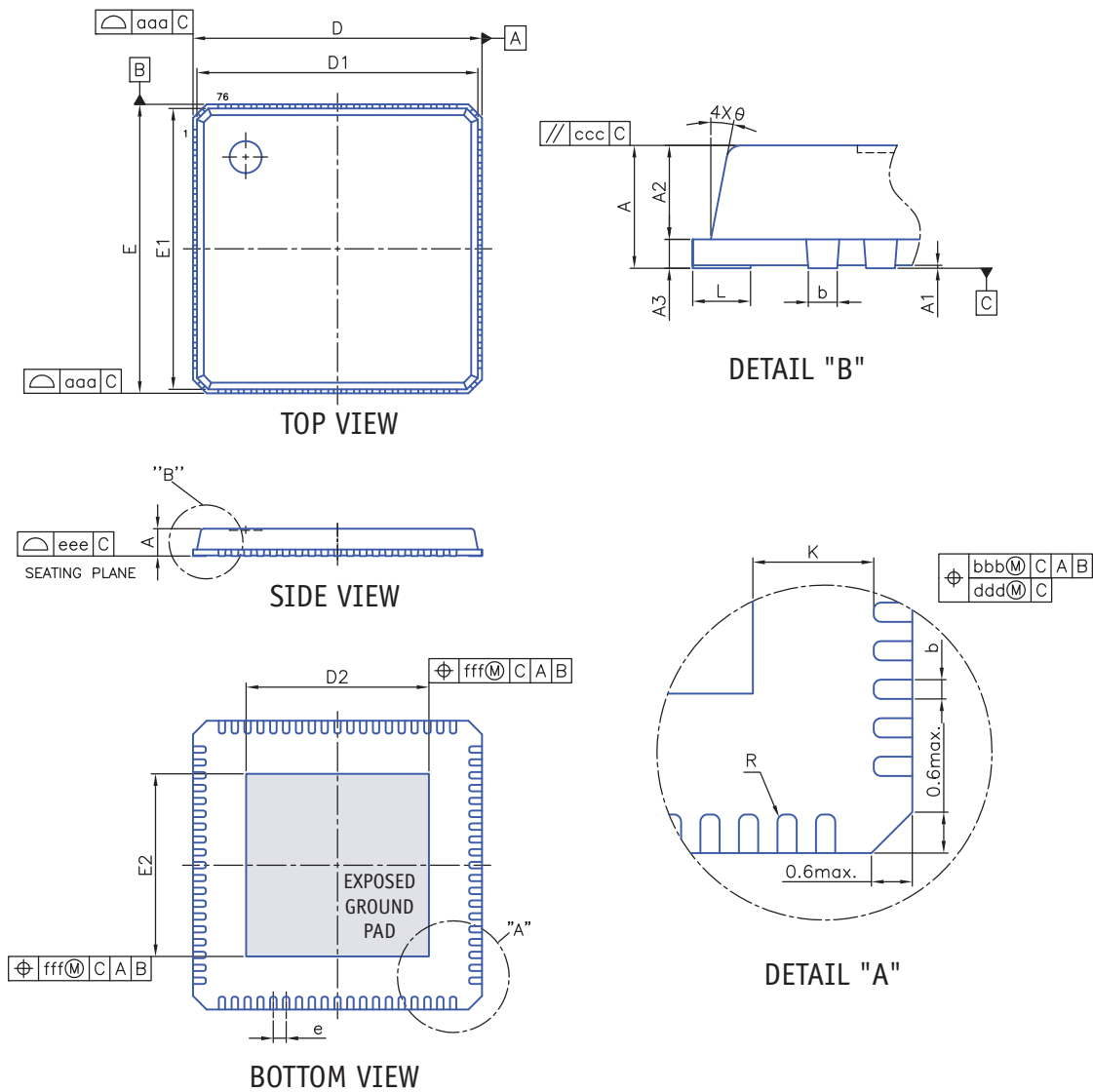

Figure 9-1. LPCC Package Details

Table 9-1. Package Dimensions

Dimension Label	Min	Nom	Max	Unit	Min	Nom	Max	Unit
A	0.80	0.85	0.90	mm	0.031	0.033	0.035	inches
A1	0.00	0.02	0.05	mm	0.000	0.001	0.002	inches
A2	0.60	0.65	0.70	mm	0.024	0.026	0.028	inches
A3	0.20 REF			mm	0.008 REF			inches
b	0.15	0.20	0.25	mm	0.006	0.008	0.010	inches
D/E	8.90	9.00	9.10	mm	0.350	0.354	0.358	inches
D1/E1	8.75 BSC			mm	0.344 BSC			inches
D2/E2	5.54	5.69	5.84	mm	0.218	0.224	0.230	inches
e	0.40 BSC			mm	0.016 BSC			inches
L	0.30	0.40	0.50	mm	0.012	0.016	0.020	inches
θ	0	—	14	°	0	—	14	°
R	0.075	—	—	mm	0.003	—	—	inches
K	0.20	—	—	mm	0.008	—	—	inches
aaa	—	—	0.10	mm	—	—	0.004	inches
bbb	—	—	0.07	mm	—	—	0.003	inches
ccc	—	—	0.10	mm	—	—	0.004	inches
ddd	—	—	0.05	mm	—	—	0.002	inches
eee	—	—	0.08	mm	—	—	0.003	inches
fff	—	—	0.10	mm	—	—	0.004	inches

[1]Controlling dimension: Millimeters.

[2]Reference document: JEDEC MO-220.

10. Ordering Information

The order number AR9287-BL1A specifies a lead-free, halogen-free, standard-temperature version of the AR9287.

The information in this document has been carefully reviewed and is believed to be accurate. Nonetheless, this document is subject to change without notice. Atheros assumes no responsibility for any inaccuracies that may be contained in this document, and makes no commitment to update or to keep current the contained information, or to notify a person or organization of any updates. Atheros reserves the right to make changes, at any time, to improve reliability, function or design and to attempt to supply the best product possible.

Document Number: MKG-1109 Rev. 1



Atheros Communications, Incorporated

5480 Great America Parkway

Santa Clara, CA 95054

tel: 408.773.5200

fax: 408.773.9940

www.atheros.com



*COMPANY CONFIDENTIAL
Subject to Change without Notice*