

GaAs MMIC SPST FET Switch

Non-Reflective DC-6 GHz



AS006M1-01, AS006M1-10, AS004M1-08, AS004M1-11

Features

- Broadband DC-6 GHz
- Available in Gull Wing 7 and 8 Lead Surface Mount Packages
- High Isolation
- 3 Nanosec Rise/Fall Time
- Low D.C. Power Consumption
- High Reliability
- Excellent Intermodulation Products/Temp. Stability
- Meets MIL-STD-883 Screening Requirements

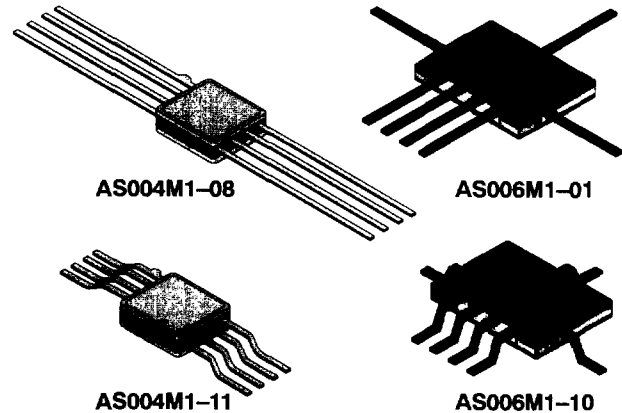

Description

These GaAs SPST non-reflective switches are offered in four separate packages for convenience of mounting. At the higher frequencies (> 4 GHz) the 7 lead flat pack has optimum performance since all leads are RF isolated. For applications that can tolerate slightly less performance to 4 GHz choose the 8 lead flatpack. Advantages are lower cost and smaller size.

These devices are useful as modulators and switches in military, instrumentation and commercial applications.

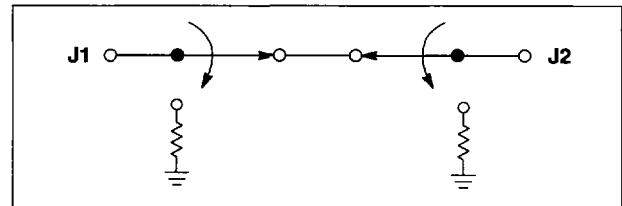

Electrical Specifications at 25°C

Part Number		AS006M1	AS004M1		
		-01,10	-08,-11		
Insertion Loss ¹	DC-1 GHz	1.1	1.1	dB	Max
	DC-2 GHz	1.2	1.2	dB	Max
	DC-4 GHz	1.6	1.6	dB	Max
	DC-6 GHz	2.2	-	dB	Max
Isolation	DC-1 GHz	60	55	dB	Min
	DC-2 GHz	55	50	dB	Min
	DC-4 GHz	50	45	dB	Min
	DC-6 GHz	40	-	dB	Min
VSWR	DC-1 GHz	1.3:1	1.3:1		Max
	DC-2 GHz	1.5:1	1.5:1		Max
	DC-4 GHz	1.8:1	1.8:1		Max
	DC-6 GHz	2.0:1	-		Max

Operating Characteristics at 25°C

Impedance	50Ω Nominal		
Switching Characteristics			
RISE, FALL (10/90% or 90/10% RF)	3	ns	Typ
ON, OFF (50% CTL to 90/10% RF)	6	ns	Typ
Video Feedthru ²	20	mV	Typ
Input Power for 1 dB Compression			
Control Voltages (Vdc)	0/-5	0/-8	
0.5-6 GHz	+24	+30	dBm Typ
0.001 GHz	+16	+20	dBm Typ
Intermodulation Intercept Point (For Two-Tone Input Power up to +13 dBm)			
Intercept Points	IP2	IP3	
0.5-6 GHz	+68	+46	dBm Typ
0.001 GHz	+57	+35	dBm Typ
Control Voltages			
V ₀ (Low)	0 to -0.2V @ 20 μA Max		
V ₀ (High)	-5V @ 50 μA to -9V @ 200 μA Max		

1. Insertion Loss changes .003 dB/°C.

2. Video Feedthru measured in 500 MHz bandwidth with 1 nanosec risetime pulse.

Performance Data

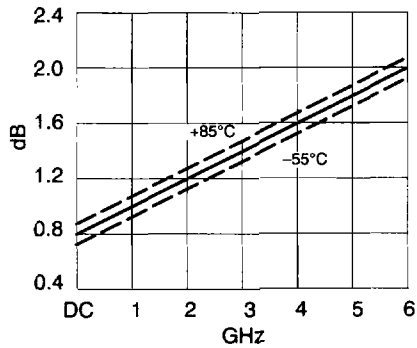

Insertion Loss vs. Frequency

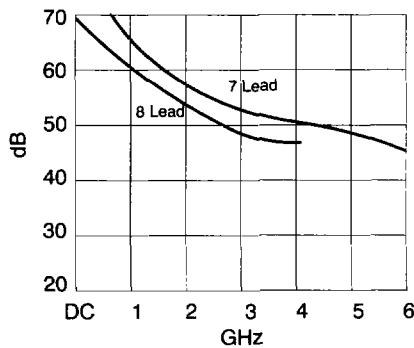

Isolation vs. Frequency

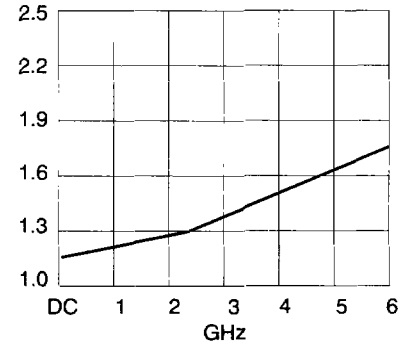

VSWR vs. Frequency

2

Switch Schematic

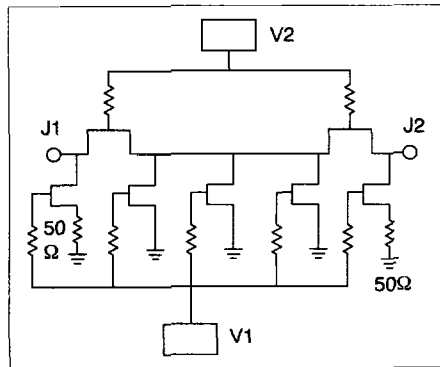

Absolute Maximum Ratings

- RF Input Power: 2W > 500 MHz 0/-8V
0.5W @ 50 MHz 0/-8V
- Control Voltage: +0.2V, -10V
- Operating Temperature: -55°C to 125°C
- Storage Temperature: -65 to 150°C
- Thermal Resistance: 25°C/W

Truth Table

V1	V2	J1-J2
0	-5	Isolation
-5	0	Insertion Loss

Pin Out

