

## FEATURES

- Precision feedback reference voltage: 0.5V (2%)
- Wide supply voltage operating range: 3.6 to 20V
- Low current consumption: 3.0mA
- Internal fixed oscillator frequency: Typ. 360KHz
- Programmable Soft-Start function (SS)
- Short Circuit Shutdown and Auto Re-start function(ARSCP)
- Built-in P-MOSFET for 3A loading capability
- Package: SOP8

## GENERAL DESCRIPTION

The AS1003 is a buck topology of switching regulator for wide operating voltage applications field. The AS1003 includes a high current P-MOSFET, high precision reference (0.5V) for comparing output voltage with feedback amplifier, an internal dead-time control and oscillator for controlling the maximum duty cycle and PWM frequency, and has power-on programmable soft start time and short circuit PMOS turn-off and auto re-start protection functions.

## APPLICATIONS

- PC Monitors
- Distributed Power Systems
- Battery Charger
- Pre-Regulator for Linear Regulators

## TYPICAL APPLICATION

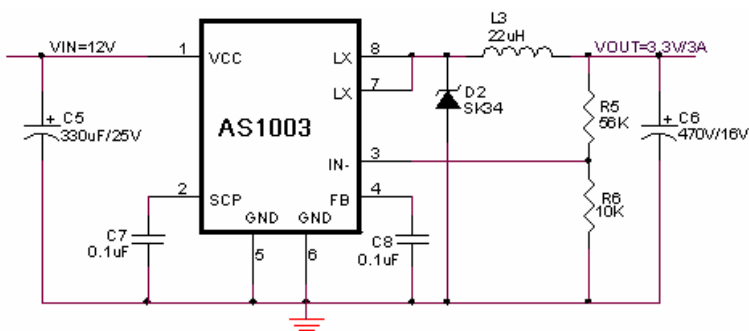
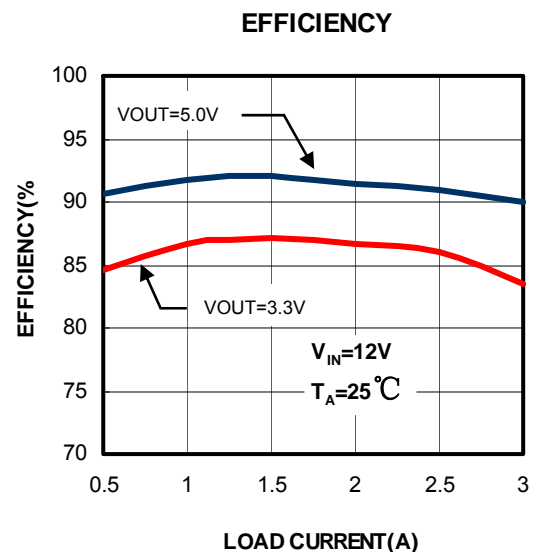

Figure1. 12V to 3.3V/2A Typical Application Circuit



### ABSOLUTE MAXIMUM RATINGS

(Note1)

V <sub>IN</sub> Voltage Range.....	3V to 20V
I <sub>OUT</sub> Output Current .....	3A
Error Amplifier IN-.....	-0.3V to 1.2V
P <sub>D</sub> Power Dissipation (T <sub>A</sub> =25°C) .....	650mW
Operating Temperature Range ....	-40°C to 85°C
Storage Temperature Range .....	-65°C to 150°C
Lead Temperature(Soldering, 10sec.) .....	260°C

### PACKAGE/ORDER INFORMATION

<p>Top View</p> <p>SOP-8 Plastic Package T<sub>JMAX</sub>=125°C (Note2)</p>	ORDER PART NUMBER
	AS1003EBT
	PART MARKING
	A1003

**Note 1:** Absolute Maximum Ratings are those values beyond which the life of a device may be impaired.

**Note 2:** T<sub>J</sub> is calculated from the ambient temperature T<sub>A</sub> and power dissipation P<sub>D</sub> according to the following formula:

$$T_J = T_A + P_D \times \Theta_{JA}$$

### ELECTRICAL CHARACTERISTICS

V<sub>IN</sub> =6V, T<sub>A</sub> = -40°C to +85°C, unless otherwise noted. Typical values are T<sub>A</sub> = 25°C

PARAMETER	CONDITIONS	MIN	TYP	MAX	UNITS
<b>Reference</b>					
V <sub>REF</sub> Voltage	COMP connected to FB	0.490	0.5	0.510	V
V <sub>REF</sub> Regulation	V <sub>CC</sub> =3.0V to 20V		2	12.5	mV
V <sub>REF</sub> Change with Temp.	T <sub>A</sub> =-25°C to 25°C		1	2	%
	T <sub>A</sub> =25°C to 85°C		1	2	
<b>Soft Start (SS)</b>					
S.S. Source Current	V <sub>SS</sub> = 0V	-7	-12	-17	μA
Soft Start Threshold Voltage	--	0.9	1.0	1.1	V
<b>Short Circuit Protection(SCP)</b>					
S.C.P Source Current	V <sub>SCP</sub> =0V	-7	-12	-17	μA
SCP Re-start/Hold time	V <sub>COMP</sub> >0.8V		1/20		-
S.C.P Threshold Voltage	V <sub>FB</sub> >450mV	1.0	1.15	1.2	V
	V <sub>FB</sub> <450mV	-	0.1	0.15	V
<b>Oscillator(OSC)</b>					
f <sub>OSC</sub>		-	360	-	KHz
f <sub>OSC</sub> Change with Voltage	V <sub>CC</sub> =3.0 V to 20V	-	5		%
f <sub>OSC</sub> Change with Temperature	T <sub>A</sub> =-25°C to 85°C	-	5	-	%

**ELECTRICAL CHARACTERISTICS(Continuous)**

$V_{IN} = 6V$ ,  $T_A = -40^{\circ}C$  to  $+85^{\circ}C$ , unless otherwise noted. Typical values are  $T_A = 25^{\circ}C$

PARAMETER	CONDITIONS	MIN	TYP	MAX	UNITS
<b>Error Amplifier(EA)</b>					
Input Threshold Voltage	$V_{FB} = 450mV$	490	500	510	mV
$V_T$ Change with Voltage	$V_{CC} = 3V$ to $20V$	-	5	20	mV
$V_T$ Change with Temperature	$T_a = -25^{\circ}C$ to $85^{\circ}C$	-	1	-	%
Input Bias Current	--	-1.0	-0.2	1.0	$\mu A$
Voltage Gain	--	-	100	-	V/V
Frequency Bandwidth	$A_v = 0$ dB	-	6	-	MHz
Output Voltage Swing Positive	$V_{IN-} = 0.3V$	0.78	0.87	-	V
Output Voltage Swing Negative	$V_{IN-} = 0.7V$	-	0.05	0.2	
Output Source Current	$V_{FB} = 450mV$	-	-45	-30	$\mu A$
Output Sink Current		30	45	-	$\mu A$

**Idle Period Adjustment**

Maximum duty cycle	$V_{IN-} = 0.2V$	-	90	-	%
--------------------	------------------	---	----	---	---

**Output**

PMOS D-S voltage	$V_{FB} = 0.1V$	-	-20	-	V
PMOS source current		-	-3		A
PMOS On resistance	$V_{CC} = 5.0V$ , $V_{IN-} = 0V$	-	40.5	52	m $\Omega$
	$V_{CC} = 10V$ , $V_{IN-} = 0V$	-	64	87	
Output leakage current	SCP active	-	-	-1	$\mu A$

**Total device**

Standby supply current	--	-	3	5	mA
Thermal Shutdown	--	-	145	-	$^{\circ}C$

**TYPICAL PERFORMANCE CHARACTERISTICS**

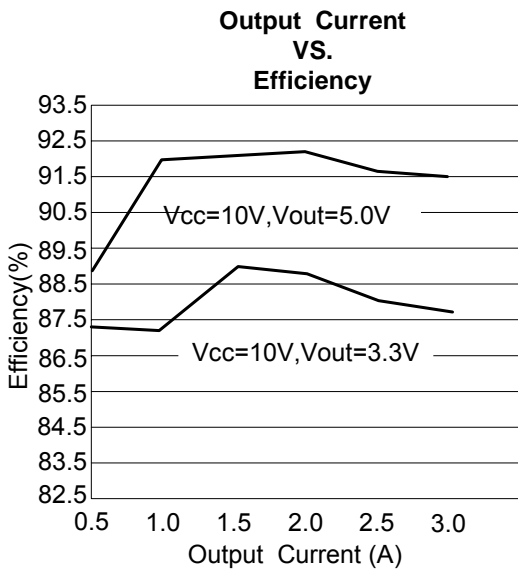
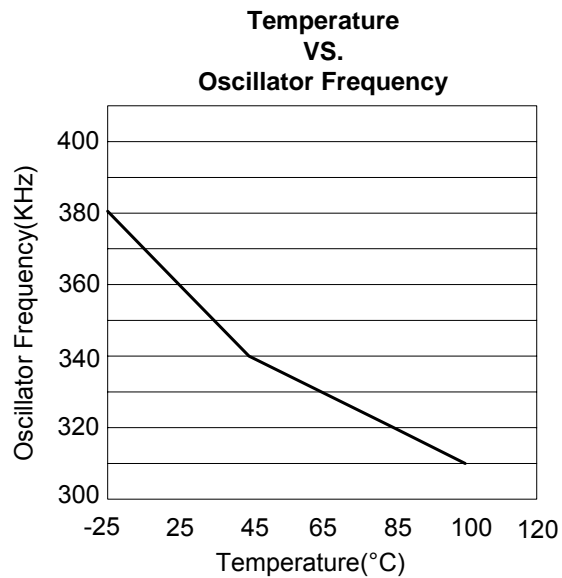
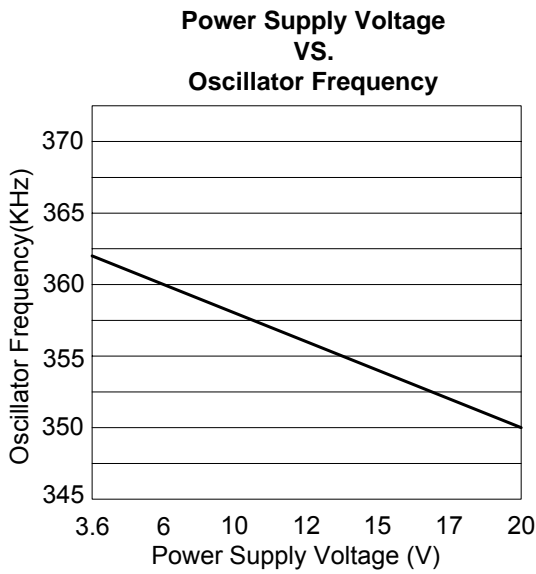
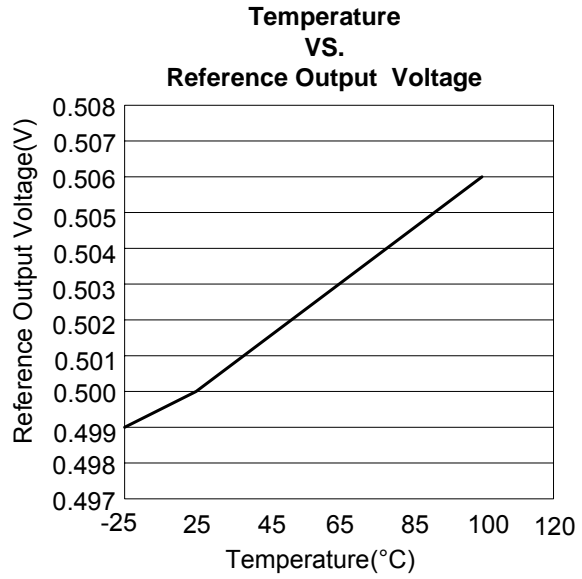
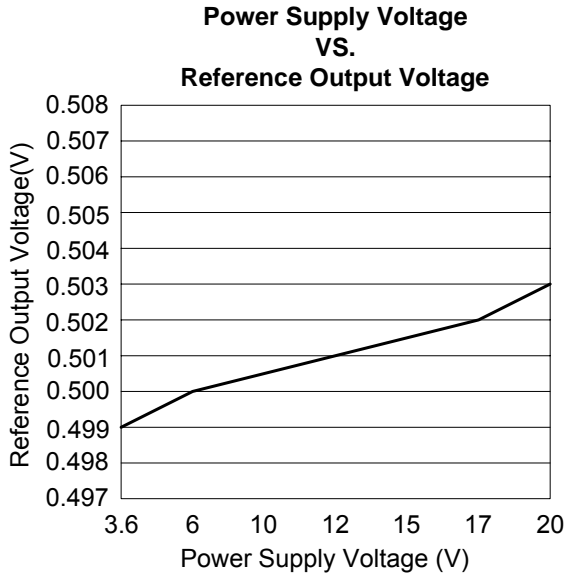

**TIMING WAVEFORM**

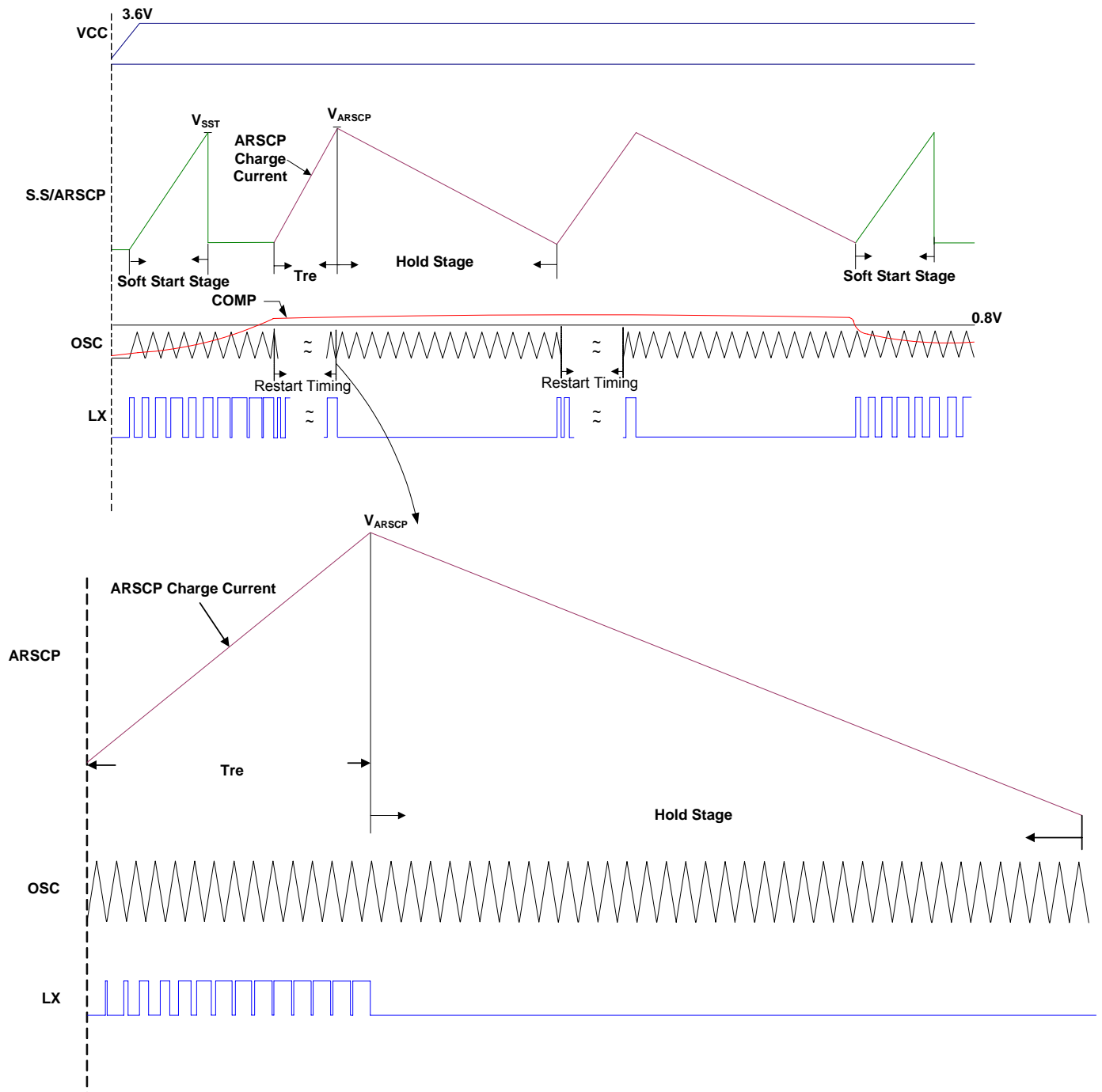

**PIN FUNCTIONS**

**VCC (Pin 1):** IC Power Supply (PMOS Source)  
**SS/SCP (Pin 2):** Connecting with a Soft-start & ARSCP timing capacitor  
**IN- (Pin 3):** Error Amplifier Inverting Input  
**FB (Pin 4):** Error Amplifier Compensation Output

**GND (Pin 5):** IC Ground  
**GND (Pin 6):** IC Ground  
**LX (Pin 7):** PMOS High Current Output  
**LX (Pin 8):** PMOS High Current Output

**BLOCK DIAGRAM**

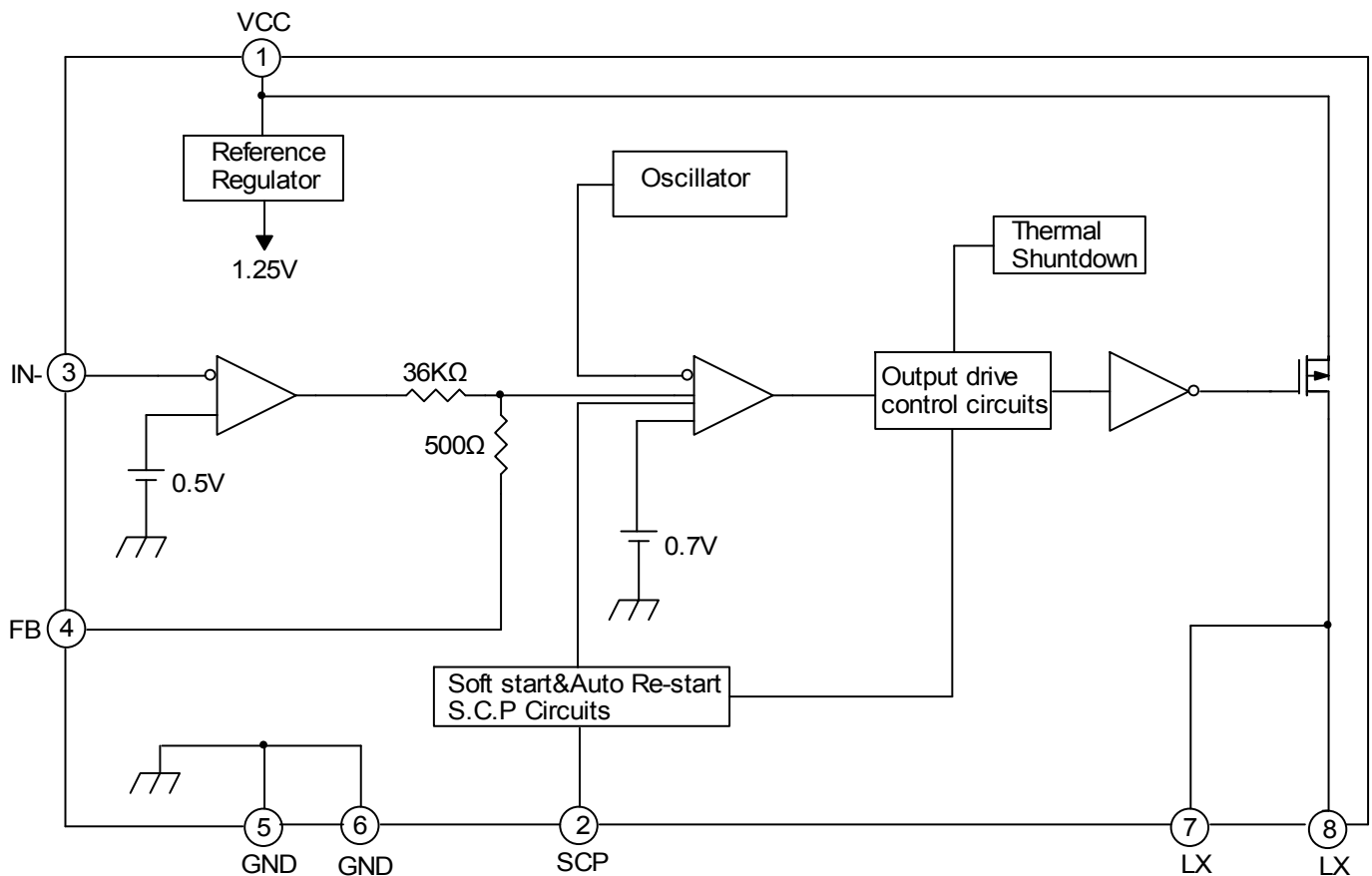

**PACKAGE DESCRIPTION** Dimensions in millimeters unless otherwise noted

**Package**  
**8-Lead Plastic SOP-8L**

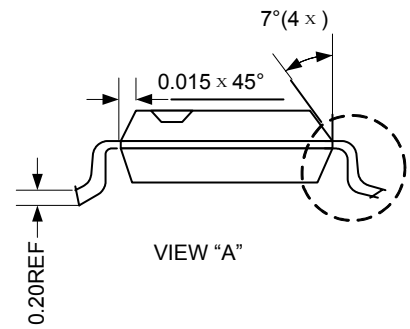
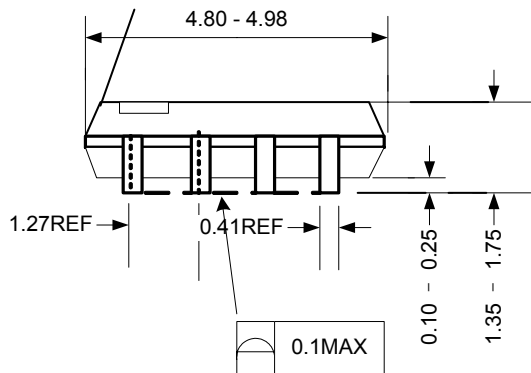
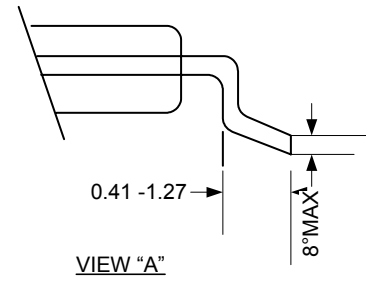
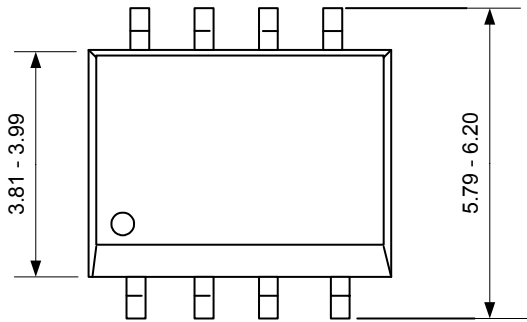

© Anisem Technology Co., Ltd

Anisem Technology assume responsibility for use of any circuitry other than circuitry entirely embodied in an AnisemTech product. No circuit patent licenses, copyrights, mask work rights, or other intellectual property rights are implied.

AnisemTech reserves the right to make changes to their products or specifications or to discontinue any product or service without notice. Customers are advised to obtain the latest version of relevant information to verify, before placing orders, that information being relied on is current and complete. All products are sold subject to the terms and conditions of sale supplied at the time of order acknowledgement, including those pertaining to warranty, patent infringement, and limitation of liability.

AnisemTech warrants performance of its semiconductor products to the specifications applicable at the time of sale in accordance with AnisemTech's standard warranty. Testing and other quality control techniques are utilized to the extent AnisemTech deems necessary to support this warranty. Specific testing of all parameters of each device is not necessarily performed.