



Austin Semiconductor, Inc.

# Voltage Comparator

## AS111

### Voltage Comparator

#### AVAILABLE AS MILITARY SPECIFICATIONS

- SMD 5962-86877
- M38510/10304B
- MIL-STD-883, 1.2.1

#### FEATURES

- Operates from single 5V supply
- Input current: 150 nA max. over temperature
- Offset current: 20 nA max. over temperature
- Differential input voltage range:  $\pm 30V$
- Power consumption: 135 mW at  $\pm 15V$

#### OPTIONS

- Packages

8 pin Ceramic DIP  
14 pin Ceramic DIP  
20 pin Ceramic LCC  
8 Lead Metal Can

#### MARKINGS

C008  
C014  
E020  
TO08

- Temperature Ranges

Extended ( $-55^{\circ}C$  to  $+125^{\circ}C$ )  
MIL-STD-883 paragraph 1.2.1  
( $-55^{\circ}C$  to  $+125^{\circ}C$ )

XT  
/883

#### GENERAL DESCRIPTION

The AS111 is a voltage comparator that has input currents nearly a thousand times lower than other similar devices like. It is also designed to operate over a wider range of supply voltages: from standard  $\pm 15V$  op amp supplies down to the single 5V supply used for IC logic. Their output is compatible with RTL, DTL and TTL as well as MOS circuits. Further, they can drive lamps or relays, switching voltages up to 50V at currents as high as 50 mA.

Both the inputs and the outputs of the AS111 can be isolated from system ground, and the output can drive loads referred to ground, the positive supply or the negative supply. Offset balancing and strobe capability are provided and outputs can be wire OR'ed. Although slower than some devices (200 ns response time vs 40 ns), this device is also much less prone to spurious oscillations.

For more products and information  
please visit our web site at

[www.austinsemiconductor.com](http://www.austinsemiconductor.com)

#### PIN ASSIGNMENT

(Top View)

##### 8 Pin Ceramic DIP (C008)

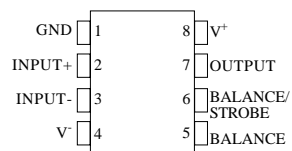

##### 14 Pin Ceramic DIP (C014)

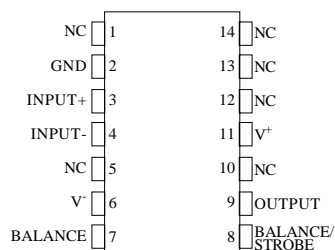

##### 8 Lead Metal Can (TO08)

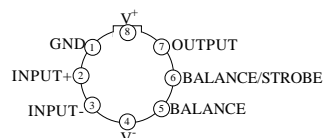

##### 20 Pin Ceramic LCC (E020)

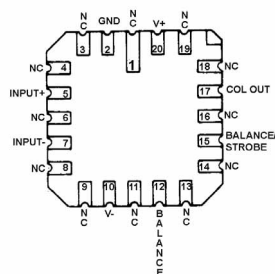



Austin Semiconductor, Inc.

# Voltage Comparator AS111

## TYPICAL APPLICATIONS<sup>3</sup>

Offset Balancing

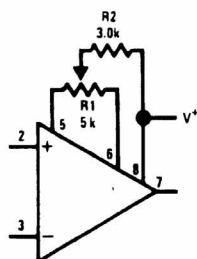

Strobing

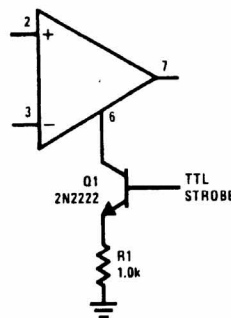

**Note:** Do Not Ground Strobe Pin. Output is turned off when current is pulled from Strobe Pin.

Increasing Input Stage Current (Note 1)

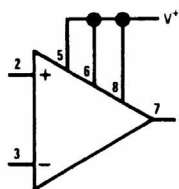

**Note 1:** Increases typical common mode slew from 7.0V/ $\mu$ s to 18V/ $\mu$ s.

Detector for Magnetic Transducer

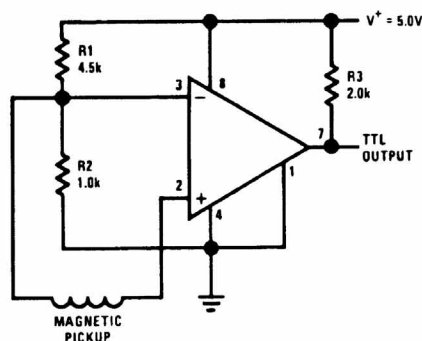

Digital Transmission Isolator

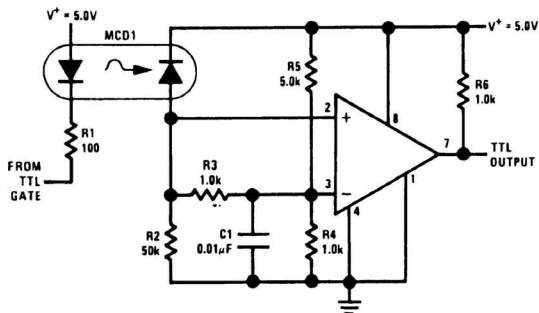

Relay Driver with Strobe

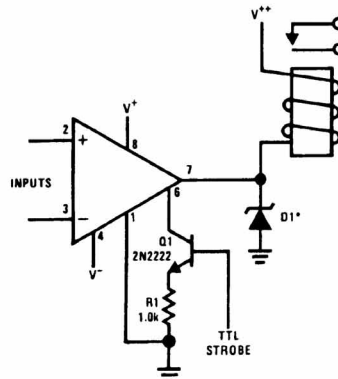

\*Absorbs inductive kickback of relay and protects IC from severe voltage transients on V<sup>+</sup> line.

**Note:** Do Not Ground Strobe Pin.



Austin Semiconductor, Inc.

# Voltage Comparator AS111

## TYPICAL APPLICATIONS (CONTINUED)<sup>3</sup>

Strobing off Both Input and Output Stages (Note 2)

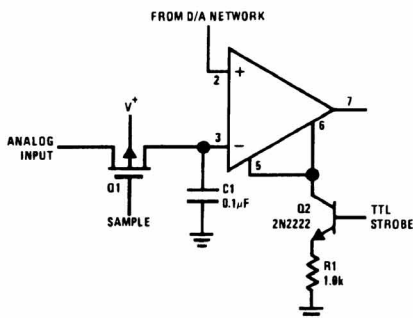

**NOTE:** Do Not Ground Strobe Pin

**NOTE 2:** Typical input current is 50pV with inputs strobed off.

**NOTE 3:** Pin connections shown on schematic diagram and typical applications are for TO08 metal can package.

Positive Peak Detector

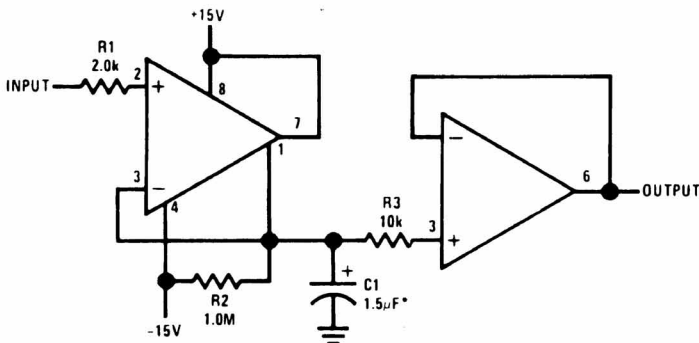

Zero Crossing Detector Driving MOS Logic

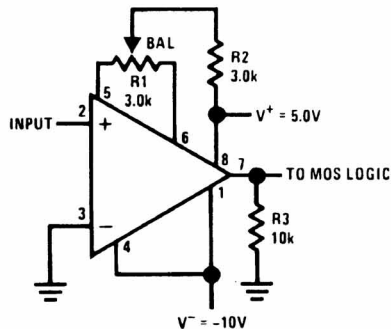

\*Solid tantalum

### ABSOLUTE MAXIMUM RATINGS<sup>\*5</sup>

Total Supply Voltage ( $V_{84}$ ).....	36V
Output to Negative Supply Voltage ( $V_{74}$ ).....	50V
Ground to Negative Supply Voltage ( $V_{14}$ ).....	30V
Differential Input Voltage.....	$\pm 30V$
Input Voltage <sup>4</sup> .....	$\pm 15V$
Output Short Circuit Duration.....	10 sec
Lead Temperature (Soldering, 10 sec).....	260°C
Voltage at Strobe Pin.....	$V^+ - 5V$

\*Stresses greater than those listed under "Absolute Maximum Ratings" may cause permanent damage to the device. This is a stress rating only and functional operation of the device at these or any other conditions above those indicated in the operation section of this specification is not implied. Exposure to absolute maximum rating conditions for extended periods may affect reliability.

**Note 4:** This rating applies for  $\pm 15$  supplies. The positive input voltage limit is 30V above the negative supply. The negative input voltage limit is equal to the negative supply voltage or 30V below the positive supply, whichever is less.

**Note 5:** The maximum junction temperature of the AS111 is 150°C. For operating at elevated temperatures, devices in the TO08 package must be derated based on a thermal resistance of 165°C/W, junction to ambient, or 20°C/W, junction to case. The thermal resistance of the dual-in-line package is 110°C/W, junction to ambient.



Austin Semiconductor, Inc.

# Voltage Comparator AS111

## ELECTRICAL CHARACTERISTICS<sup>6</sup>

PARAMETER	CONDITIONS	MIN	TYP	MAX	UNITS
Input Offset Voltage <sup>7</sup>	$T_A = 25^\circ\text{C}$ , $R_S \leq 50\text{K}$		0.7	3.0	mV
Input Offset Current	$T_A = 25^\circ\text{C}$		4.0	10	nA
Input Bias Current	$T_A = 25^\circ\text{C}$		60	100	nA
Voltage Gain	$T_A = 25^\circ\text{C}$	40	200		V/mV
Response Time <sup>8</sup>	$T_A = 25^\circ\text{C}$		200		ns
Saturation Voltage	$V_{IN} \leq -5\text{mV}$ , $I_{OUT} = 50\text{mA}$ , $T_A = 25^\circ\text{C}$		0.75	1.5	V
Strobe ON Current <sup>9</sup>	$T_A = 25^\circ\text{C}$		2.0	5.0	mA
Output Leakage Current	$V_{IN} \geq 5\text{mV}$ , $I_{OUT} = 35\text{V}$ , $T_A = 25^\circ\text{C}$ , $I_{STROBE} = 3\text{mA}$		0.2	10	nA
Input Offset Voltage <sup>7</sup>	$R_S \leq 50\text{k}$			4.0	mV
Input Offset Current <sup>7</sup>				20	nA
Input Bias Current				150	nA
Input Voltage Range	$V^+ = 15\text{V}$ , $V^- = -15\text{V}$ , Pin 7 Pull-Up May Go To 5V	-14.5	13.8, -14.7	13.0	V
Saturation Voltage	$V^+ \geq 4.5\text{V}$ , $V^- = 0$ , $V_{IN} \leq -6\text{mV}$ , $I_{OUT} \leq 8\text{mA}$		0.23	0.4	V
Output Leakage Current	$V_{IN} \geq 5\text{mV}$ , $I_{OUT} = 35\text{V}$		0.1	0.5	$\mu\text{A}$
Positive Supply Current	$T_A = 25^\circ\text{C}$		5.1	6.0	mA
Negative Supply Current	$T_A = 25^\circ\text{C}$		4.1	5.0	mA

**Note 6:** These specifications apply for  $V_S = \pm 15\text{V}$  and Ground pin at ground, and  $-55^\circ\text{C} \leq T_A \leq +125^\circ\text{C}$ , unless otherwise stated. The offset voltage, offset current and bias current specifications apply for any supply voltage from a single 5V supply up to  $\pm 15\text{V}$  supplies.

**Note 7:** The offset voltages and offset currents given are the maximum values required to drive the output within a volt of either supply with a 1mA load. Thus, these parameters define an error band and take into account the worst-case effects of voltage gain and  $R_S$ .

**Note 8:** The response time specified (see definitions) is for a 100 mV input step with 5 mV overdrive.

**Note 9:** This specification gives the range of current which must be drawn from the strobe pin to ensure the output is properly disabled. Do not short the strobe pin to ground; it should be current driven at 3 to 5 mA.



Austin Semiconductor, Inc.

# Voltage Comparator AS111

## TYPICAL PERFORMANCE CHARACTERISTICS

Input Bias Current

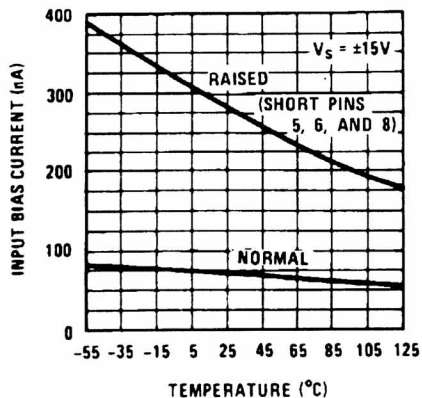

Input Bias Current

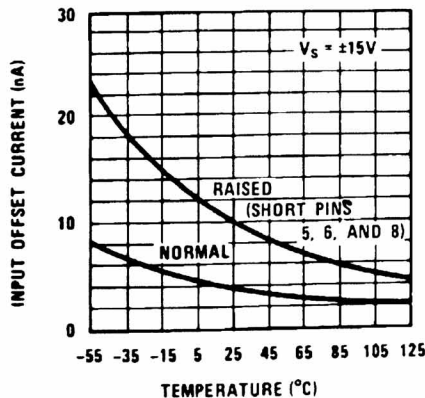

Input Bias Current

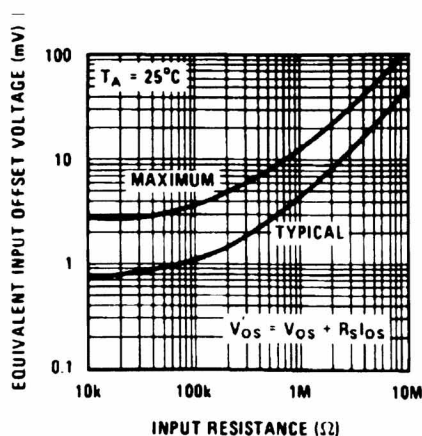

Input Bias Current

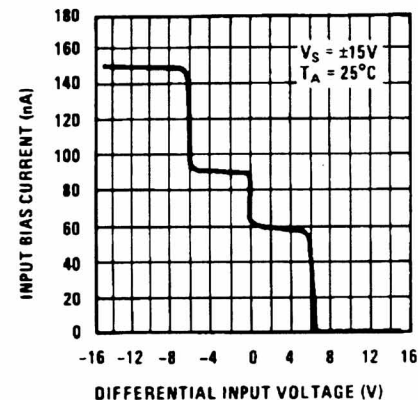

Input Bias Current

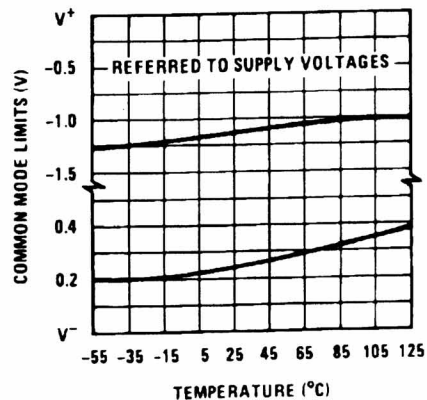

Input Bias Current

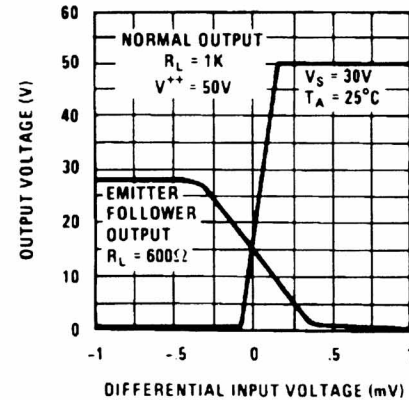



Austin Semiconductor, Inc.

# Voltage Comparator AS111

## TYPICAL PERFORMANCE CHARACTERISTICS (CONTINUED)

Input Bias Current  
Input Overdrives

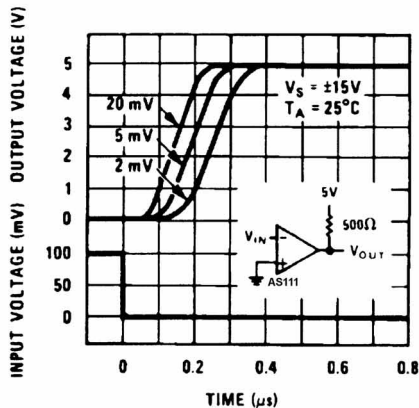

Input Bias Current  
Input Overdrives

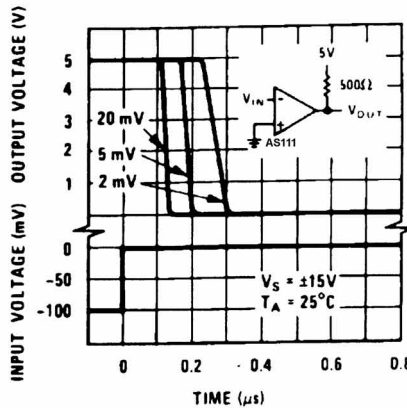

Input Bias Current

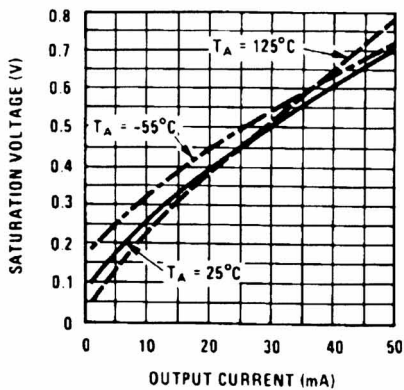

Response Time for Various  
Input Overdrives

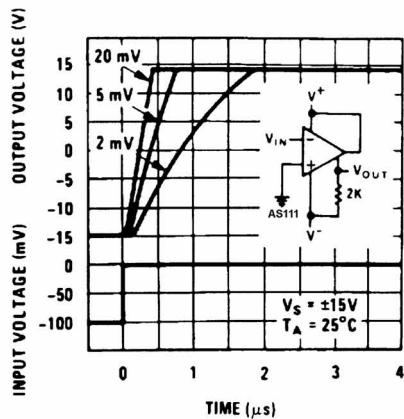

Response Time for Various  
Input Overdrives

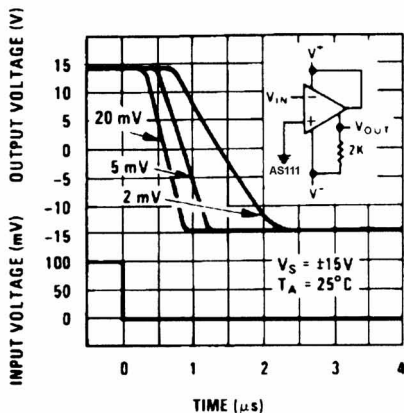

Output Limiting Characteristics

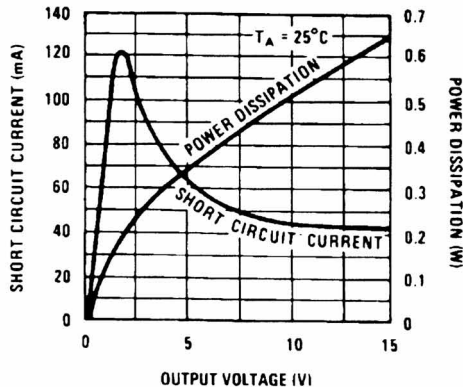



Austin Semiconductor, Inc.

# Voltage Comparator AS111

## TYPICAL PERFORMANCE CHARACTERISTICS (CONTINUED)

Supply Current

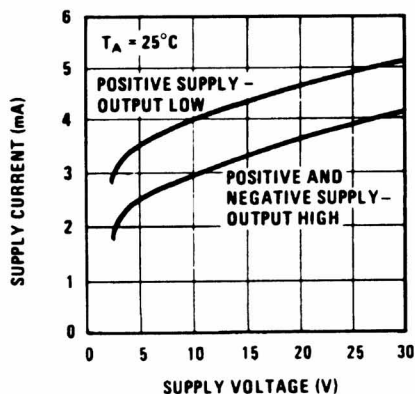

Supply Current

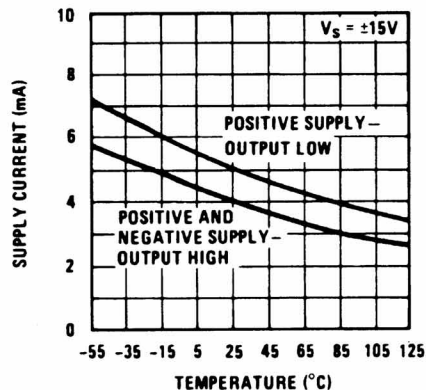

Leakage Currents

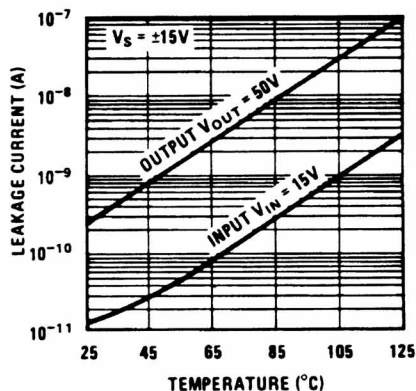

### CIRCUIT TECHNIQUES FOR AVOIDING OSCILLATIONS IN COMPARATOR APPLICATIONS

When a high-speed comparator such as the AS111 is used with fast input signals and low source impedances, the output response will normally be fast and stable, assuming that the power supplies have been bypassed (with  $0.1\ \mu\text{F}$  discapacitors), and that the output signal is routed well away from the inputs (pins 2 and 3) and also away from pins 5 and 6.

However, when the input signal is a voltage ramp or a slow sine wave, or if the signal source impedance is high (1 k $\Omega$  to 100 k $\Omega$ ), the comparator may burst into oscillation near the crossing-point. This is due to the high gain and wide bandwidth of comparators like the AS111. To avoid oscillation or instability in such a usage, several precautions are recommended, as shown in Figure 1 below.

1. The trim pins (pins 5 and 6) act as unwanted auxiliary inputs. If these pins are not connected to a trim-pot, they

should be shorted together. If they are connected to a trim-pot, a  $0.01\ \mu\text{F}$  capacitor C1 between pins 5 and 6 will minimize the susceptibility to AC coupling. A smaller capacitor is used if pin 5 is used for positive feedback as in Figure 1.

2. Certain sources will produce a cleaner comparator output waveform if a 100 pF to 1000 pF capacitor C2 is connected directly across the input pins.

3. When the signal source is applied through a resistive network,  $R_S$ , it is usually advantageous to choose an  $R_S$  of substantially the same value, both for DC and for dynamic (AC) considerations. Carbon, tin-oxide, and metal-film resistors have all been used successfully in comparator input circuitry. Inductive wirewound resistors are not suitable.

(continued)

www.DataSheet4U.com



Austin Semiconductor, Inc.

# Voltage Comparator

## AS111

### APPLICATION HINTS (CONTINUED)

4. When comparator circuits use input resistors (eg. summing resistors), their value and placement are particularly important. In all cases the body of the resistor should be close to the device or socket. In other words there should be very little lead length or printed-circuit foil run between comparator and resistor to radiate or pick up signals. The same applies to capacitors, pots, etc. For example, if  $R_s=10\text{ kW}$ , as little as 5 inches of lead between the resistors and the input pins can result placing resistors close to the comparator.

5. Since feedback to almost any pin of a comparator can result in oscillation, the printed-circuit layout should be engineered thoughtfully. Preferably there should be a groundplane under the AS111 circuitry, for example, one side of a double-layer circuit card. Ground foil (or, positive supply or negative supply foil) should extend between the output and the inputs, to act as a guard. The foil connections for the inputs should be as small and compact as possible, and should be essentially surrounded by ground foil on all sides, to guard against capacitive coupling from any high-level signals (such as the output). If pins 5 and 6 are not used, they should be shorted together. If they are connected to a trim-pot, the trim-pot should be located, at most, a few inches away from the AS111, and the  $0.01\text{ }\mu\text{F}$  capacitor should be installed. If this capacitor cannot be used, a shielding printed-circuit foil may be advisable between pins 6 and 7. The power supply bypass capacitors should be located within a couple inches of the AS111. (Some other comparators require the power-supply bypass to be located immediately adjacent to the comparator.)

6. It is a standard procedure to use hysteresis (positive feedback) around a comparator, to prevent oscillation, and to avoid excessive noise on the output because the comparator is a good amplifier for its own noise. In the circuit of Figure 2, the feedback from the output to the positive input will cause about 3 mV of hysteresis. However, if  $R_s$  is larger than  $100\Omega$ , such as  $50\text{ k}\Omega$ , it would not be reasonable to simply increase the value of the positive feedback resistor above  $510\text{ k}\Omega$ . The circuit of Figure 3 could be used, but it is rather awkward. See the notes in paragraph 7 below.

7. When both inputs of the AS111 are connected to active signals, or if a high-impedance signal is driving the positive input of the AS111 so that positive feedback would be disruptive, the circuit of Figure 1 is ideal. The positive feedback is to pin 5 (one of the offset adjustment pins). It is sufficient to cause 1 to 2 mV hysteresis and sharp transitions with input triangle waves from a few Hz to hundreds of kHz. The positive-feedback signal across the  $82\Omega$  resistor swings  $240\text{ mV}$  below the positive supply. This signal is centered around the nominal voltage at pin 5, so this feedback does not add to the  $V_{OS}$  of the comparator. As much as  $8\text{ mV}$  of  $V_{OS}$  can be trimmed out, using the  $5\text{ k}\Omega$  pot and  $3\text{ k}\Omega$  resistor as shown.

8. These application notes apply specifically to the AS111 family of comparators, and are applicable to all high-speed comparators in general, (with the exception that not all comparators have trim pins).

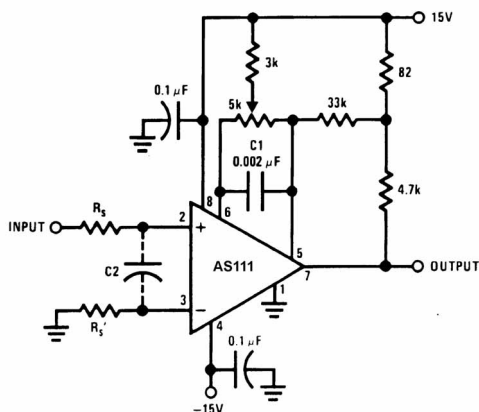

FIGURE 1. Improved Positive Feedback

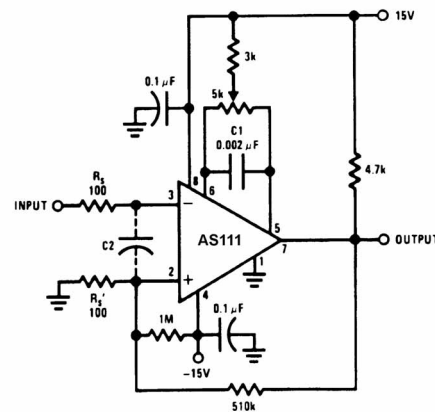

FIGURE 2. Conventional Positive Feedback

**NOTE:** Pin connections shown are for the TO08 can package.

AS111  
Rev. 1.6 6/05

Austin Semiconductor, Inc. reserves the right to change products or specifications without notice.





Austin Semiconductor, Inc.

# Voltage Comparator AS111

## APPLICATION HINTS (CONTINUED)

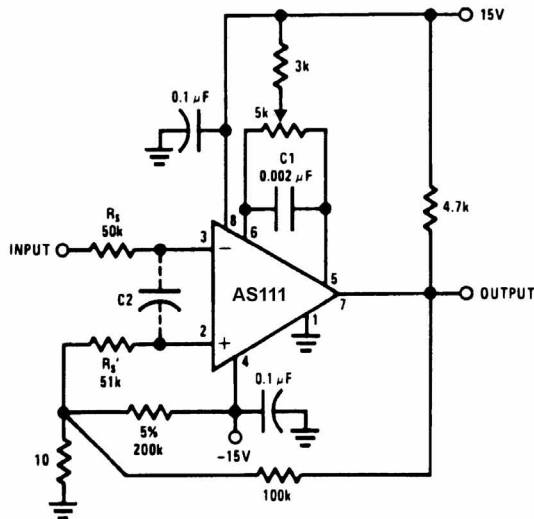
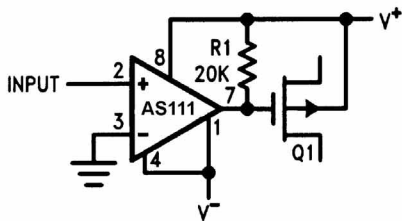

FIGURE 3. Positive Feedback with High Source Resistance

## TYPICAL APPLICATIONS (Pin numbers refer to TO08 can package)

### Zero Crossing Detector Driving MOS Switch



### 100 kHz Free Running Multivibrator

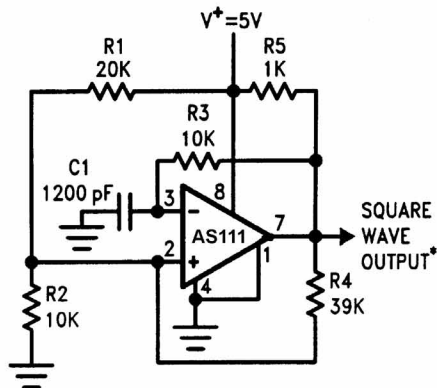

\*TTL or DTL fanout of two



Austin Semiconductor, Inc.

# Voltage Comparator AS111

## TYPICAL APPLICATIONS (Pin numbers refer to TO08 can package)(Continued)

### 10Hz to 10kHz Voltage Controlled Oscillator

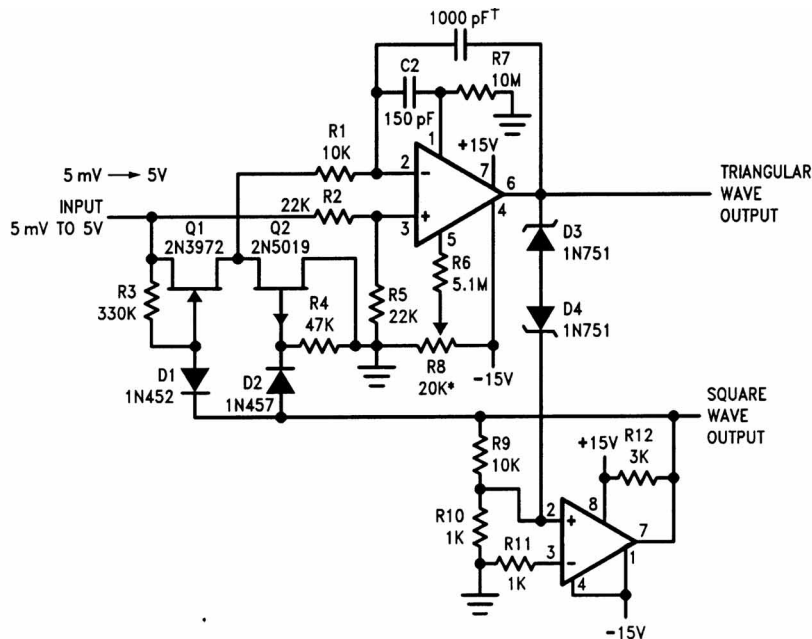

\*Adjust for symmetrical square wave time when  $V_{IN} = 5 \text{ mV}$   
 †Minimum capacitance 20 pF Maximum frequency 50 kHz

#### Driving Ground-Referred Load

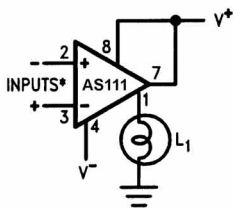

\*Input polarity is reversed when using pin 1 as output.

#### Using Clamp Diodes to Improve Response

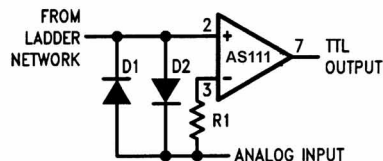

#### TTL Interface with High Level Logic

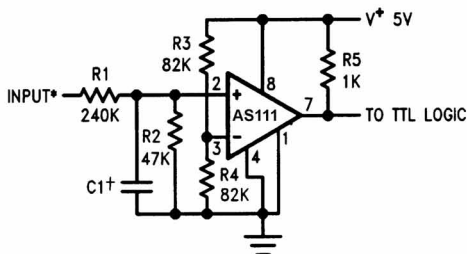

www.DataSheet4U.com

Values shown are for a 0 to 30V logic swing and a 15V threshold.  
 †May be added to control speed and reduce susceptibility to noise spikes.



Austin Semiconductor, Inc.

# Voltage Comparator AS111

## TYPICAL APPLICATIONS (Pin numbers refer to TO08 can package)(Continued)

Crystal Oscillator

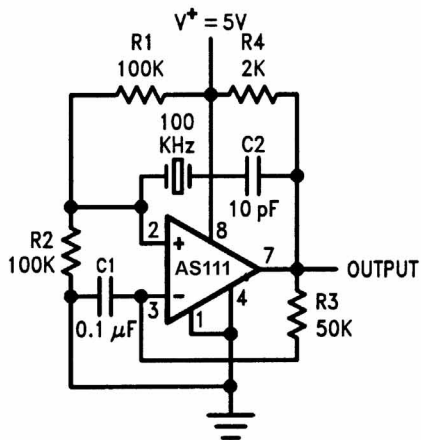

Comparator and Solenoid Driver

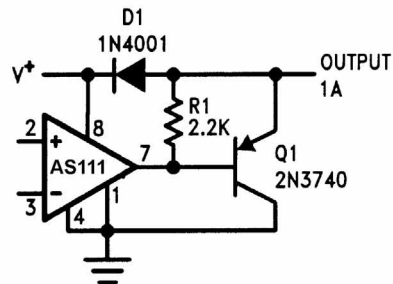

Precision Squarer

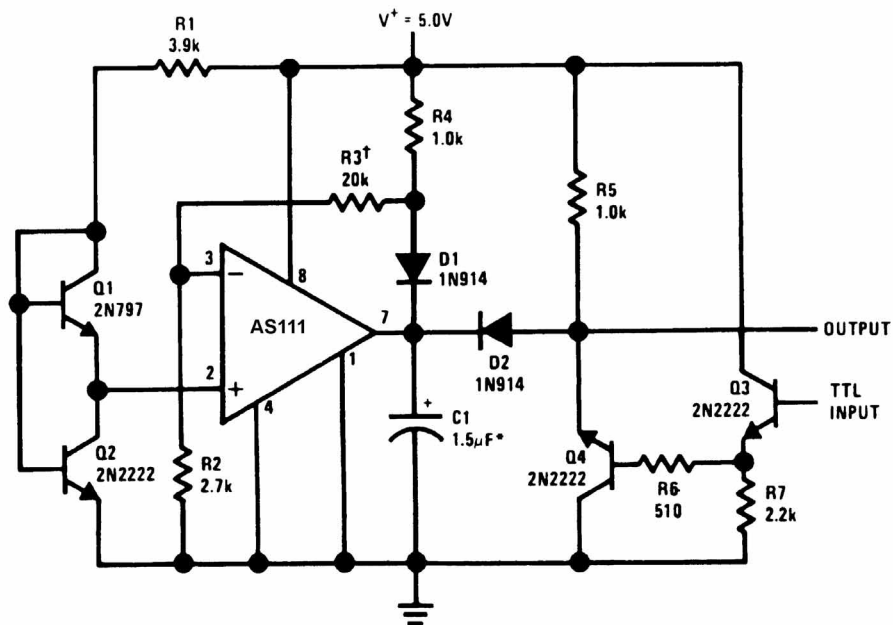



Austin Semiconductor, Inc.

# Voltage Comparator AS111

## TYPICAL APPLICATIONS (Pin numbers refer to TO08 can package)(Continued)

Low Voltage Adjustable Reference Supply

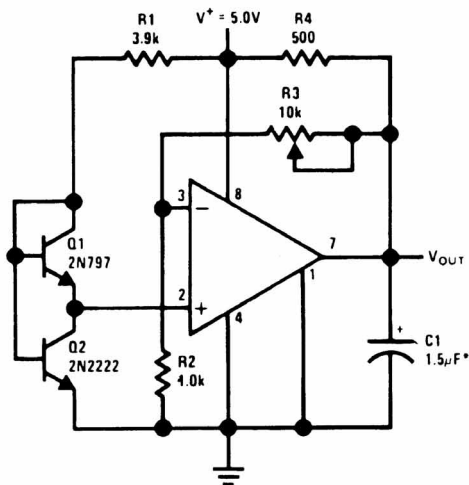

\*Solid tantalum

Positive Peak Detector

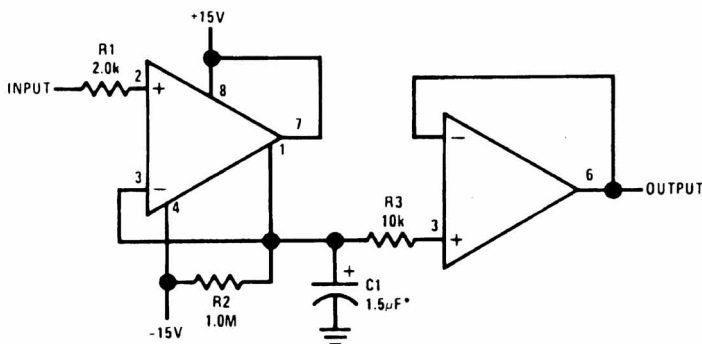

\*Solid tantalum

Zero Crossing Detector Driving MOS Logic

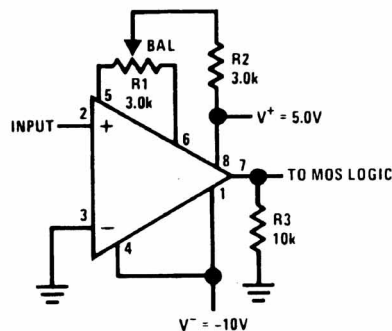

Negative Peak Detector

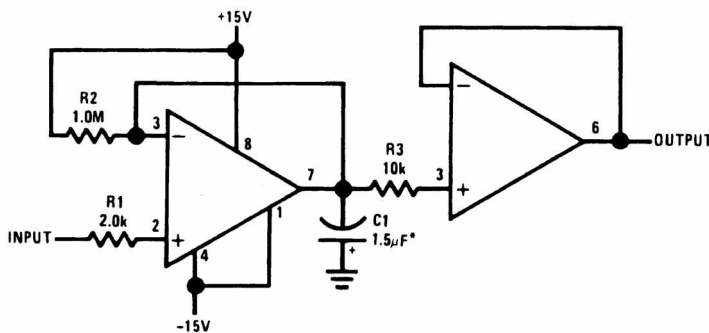

\*Solid tantalum



Austin Semiconductor, Inc.

# Voltage Comparator

## AS111

### TYPICAL APPLICATIONS (Pin numbers refer to TO08 can package)(Continued)

Precision Photodiode Comparator

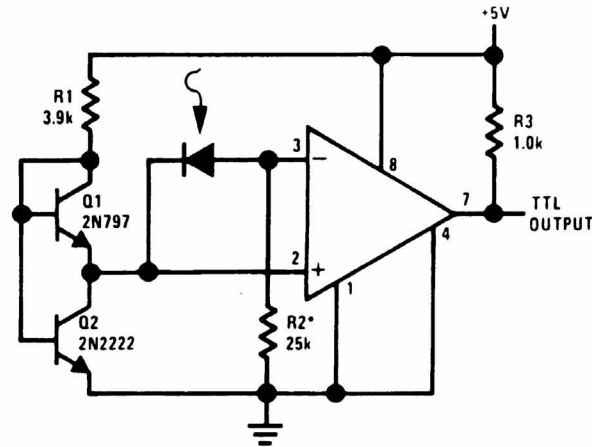

\*R2 sets the comparison level. At comparison, the photodiode has less than 5 mV across it, decreasing leakages by an order of magnitude.

Switching Power Amplifier

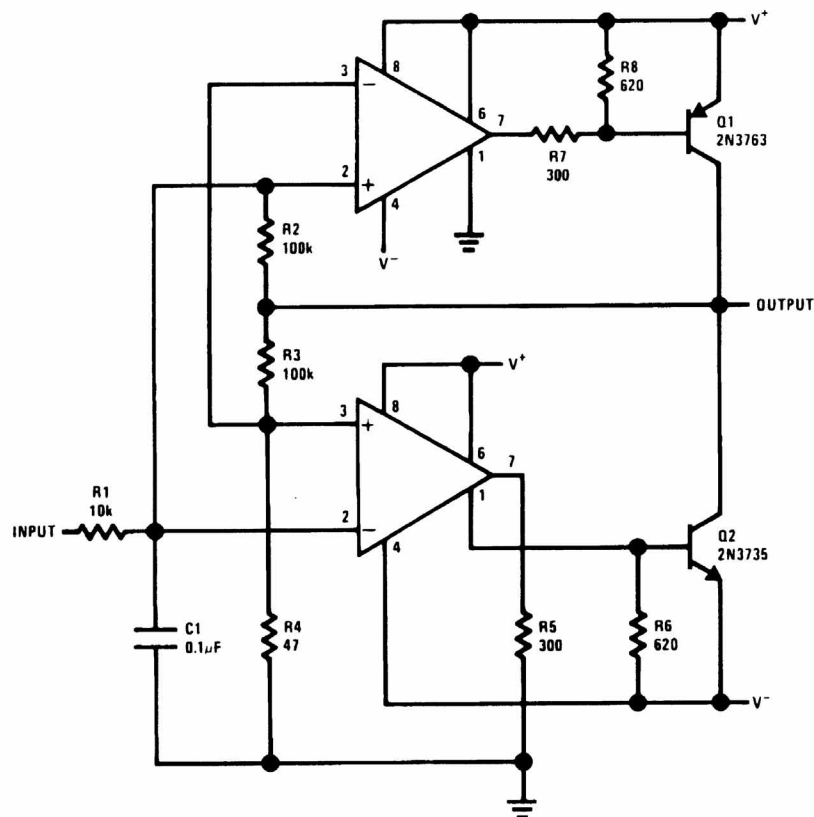



Austin Semiconductor, Inc.

# Voltage Comparator AS111

## TYPICAL APPLICATIONS (Pin numbers refer to TO08 can package)(Continued)

Switching Power Amplifier

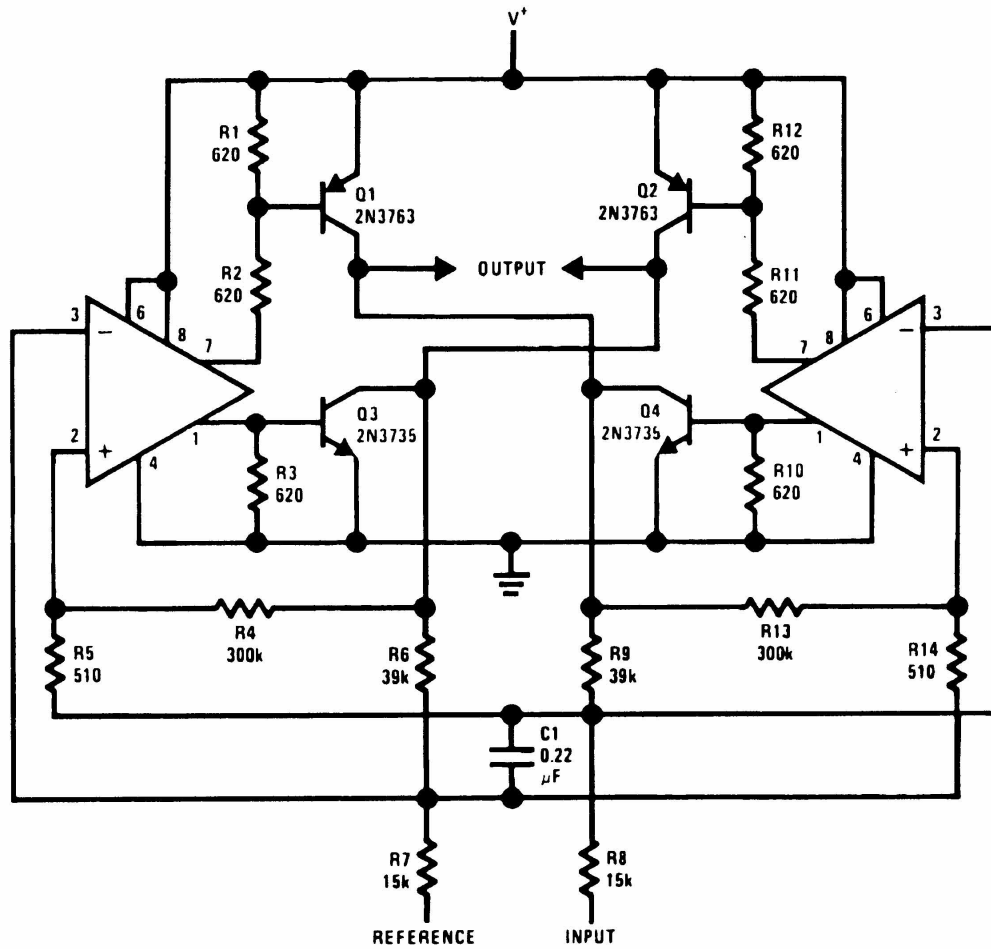



Austin Semiconductor, Inc.

# Voltage Comparator AS111

## SCHEMATIC DIAGRAM<sup>20</sup>

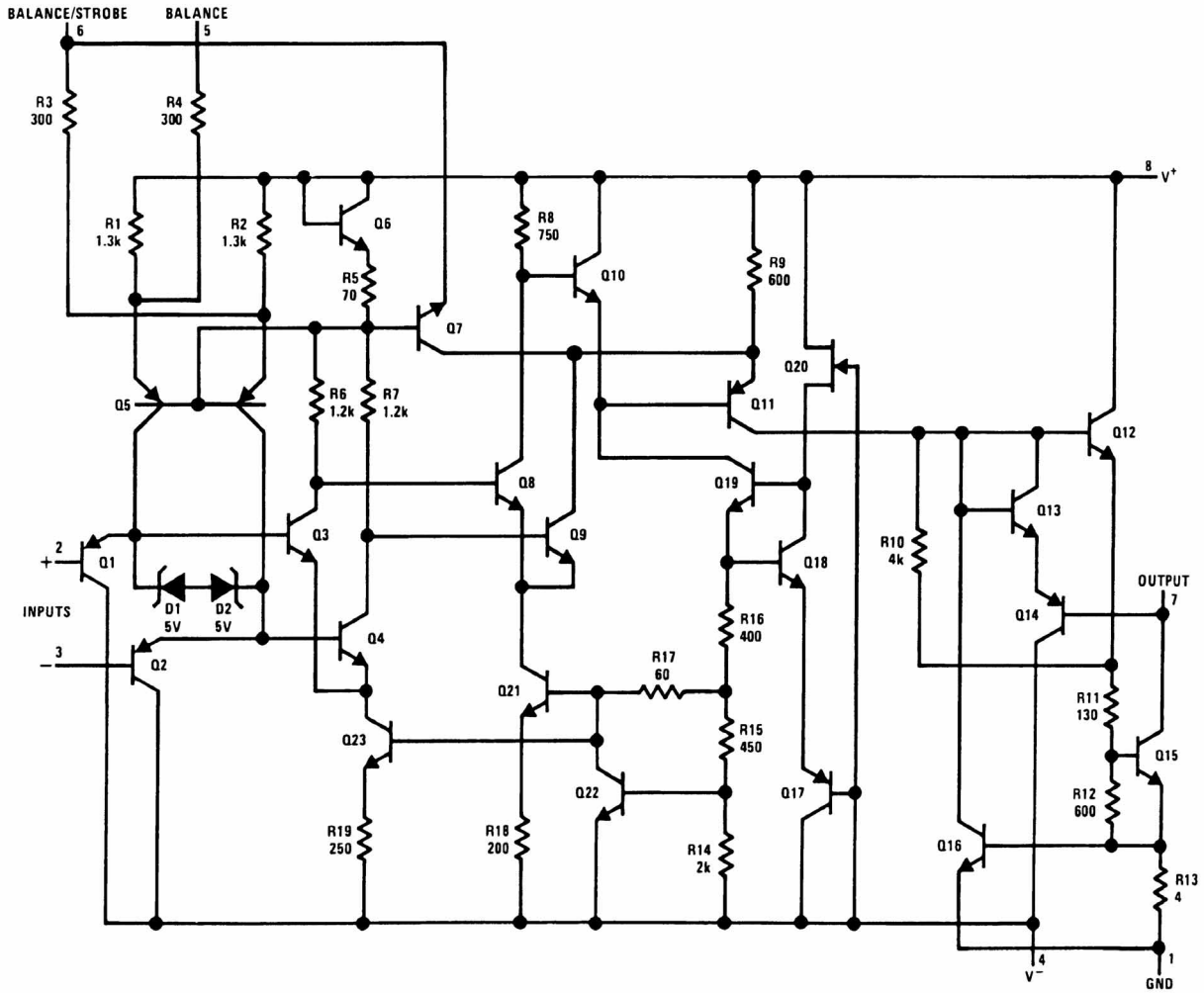

NOTE 20: Pin connections shown on schematic diagram are for the TO08 can package.



Austin Semiconductor, Inc.

# Voltage Comparator AS111

## MECHANICAL DEFINITIONS\*

ASI Case (Package Designator C008)  
SMD 5962-86877, Case Outline P

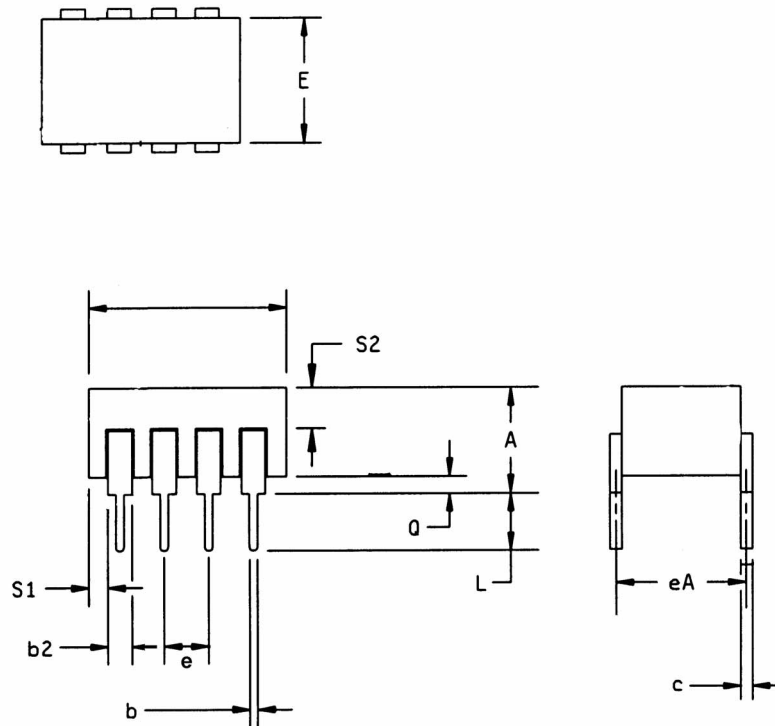

SYMBOL	ASI SPECIFICATIONS	
	MIN	MAX
A	---	0.200
b	0.014	0.026
b2	0.045	0.065
c	0.008	0.018
D	---	0.405
E	0.220	0.310
e	0.100 BCS	
eA	0.300 BSC	
L	0.125	0.200
Q	0.015	0.060
S1	0.005	---
S2	0.005	---

www.DataSheet4U.com

\*All measurements are in inches.

AS111  
Rev. 1.6 6/05

Austin Semiconductor, Inc. reserves the right to change products or specifications without notice.





Austin Semiconductor, Inc.

# Voltage Comparator AS111

## MECHANICAL DEFINITIONS\*

ASI Case (Package Designator C014)  
M38510/10304B, Case Outline C

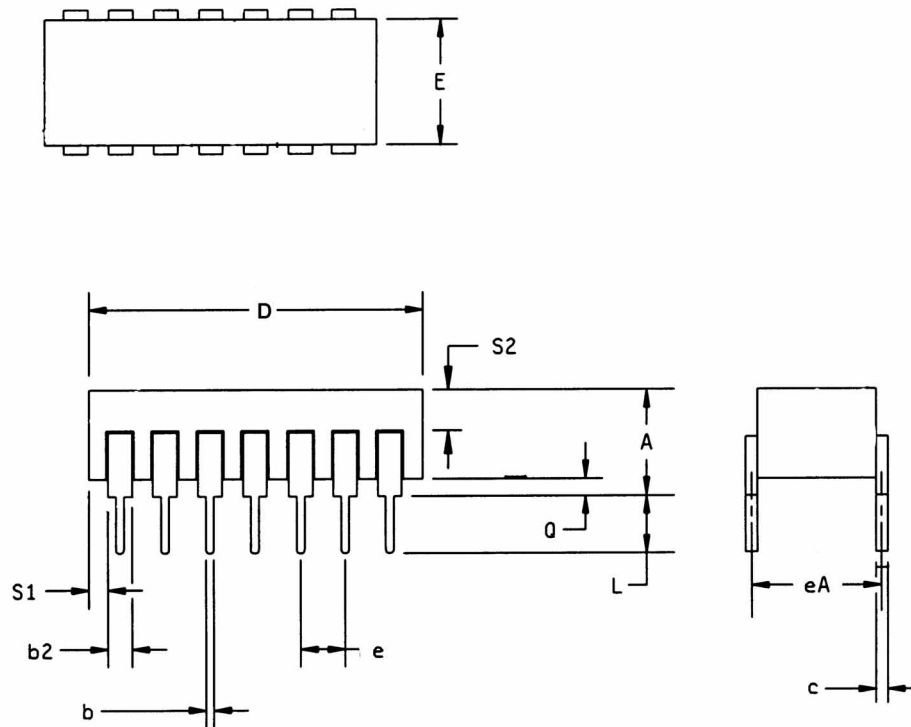

SYMBOL	ASI SPECIFICATIONS	
	MIN	MAX
A	---	0.200
b	0.014	0.026
b2	0.045	0.065
c	0.008	0.018
D	---	0.785
E	0.220	0.310
e	0.100 BCS	
eA	0.300 BSC	
L	0.125	0.200
Q	0.015	0.060
S1	0.005	---
S2	0.005	---

www.DataSheet4U.com

\*All measurements are in inches.

AS111  
Rev. 1.6 6/05

Austin Semiconductor, Inc. reserves the right to change products or specifications without notice.



Austin Semiconductor, Inc.

# Voltage Comparator AS111

## MECHANICAL DEFINITIONS\*

ASI Case (Package Designator E020)  
SMD 5962-86877, Case Outline 2

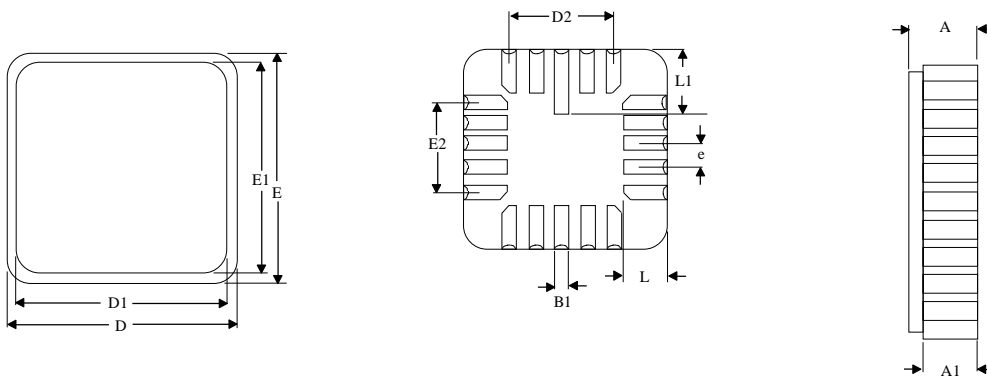

SYMBOL	ASI SPECIFICATIONS	
	MIN	MAX
A	0.060	0.100
A1	0.050	0.088
B1	0.022	0.028
D/E	0.342	0.358
D1/E1	---	0.358
D2/E2	0.200 BSC	
e	0.050 BSC	
L	0.045	0.055
L1	0.075	0.095



Austin Semiconductor, Inc.

# Voltage Comparator AS111

## MECHANICAL DEFINITIONS\*

ASI Case (Package Designator TO08)

SMD 5962-86877, Case Outline G

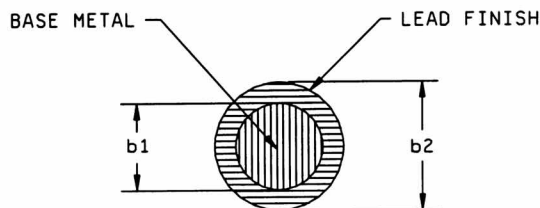
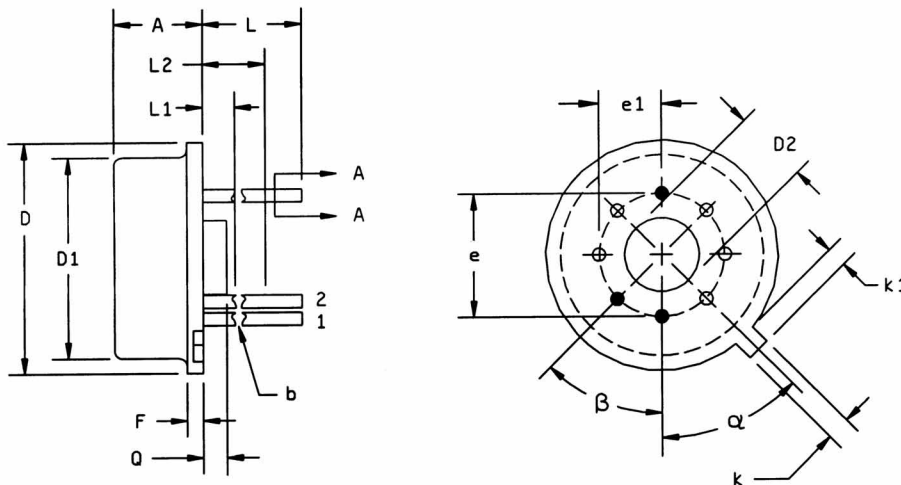

SECTION A-A

SYMBOL	ASI SPECIFICATIONS	
	MIN	MAX
A	0.165	0.185
b	0.016	0.019
b1	0.016	0.021
b2	0.016	0.024
D	0.335	0.375
D1	0.305	0.335
D2	0.110	0.160
e	0.200 BSC	
e1	0.100 BSC	
F	---	0.040
k	0.027	0.034
k1	0.027	0.045
L	0.500	0.750
L1	---	0.050
L2	0.250	---
Q	0.010	0.045
$\alpha$	45° BSC	
$\beta$	45° BSC	

\*All measurements are in inches.



Austin Semiconductor, Inc.

# Voltage Comparator AS111

## ORDERING INFORMATION

EXAMPLE: AS111C008/883C

Device Number	Package Type	Process
AS111	C008	/*

EXAMPLE: AS111C014/XT

Device Number	Package Type	Process
AS111	C014	/*

EXAMPLE: AS111E020/XT

Device Number	Package Type	Process
AS111	E020	/*

EXAMPLE: AS111TO08/883C

Device Number	Package Type	Process
AS111	TO08	/*

### \*AVAILABLE PROCESSES:

XT = Extended Temperature Range                      -55°C to +125°C  
 /883C = MIL-STD-883 paragraph 1.2.1                      -55°C to +125°C



Austin Semiconductor, Inc.

Voltage  
Comparator  
**AS111**

## ASI TO DSCC PART NUMBER CROSS REFERENCE

### ASI PART NUMBER

AS111C008/883C  
AS111E020/883C  
AS111TO08/883C

AS111C008/883C  
AS111E020/883C  
AS111TO08/883C  
AS111C014/883C

### DSCC PART NUMBER

5962-8687701PA  
5926-86877012A  
5962-8687701GA

M38510/10304BPA  
M38510/10304B2A  
M38510/10304BGA  
M38510/10304BCA