

# AS1312

## Ultra Low Quiescent Current, Hysteretic DC-DC Step-up Converter

### General Description

The AS1312 is an ultra low IQ hysteretic step-up DC-DC converter.

The AS1312 achieves an efficiency of up to 94% and is designed to operate from a +0.7V to +5.0V supply, the output voltage is fixed in 50mV steps from +2.5V to 5.0V.

In order to save power the AS1312 features a shutdown mode, where it draws less than 100nA. In shutdown mode the battery is not connected to the output.

If the input voltage exceeds the output voltage the device is in a feedthrough mode and the input is directly connected to the output voltage.

In light load operation, the device enters a sleep mode when most of the internal operating blocks are turned off in order to save power. This mode is active approximately 50µs after a current pulse provided that the output is in regulation.

The AS1312 also offers an adjustable low battery detection. If the battery voltage decreases below a threshold defined by two external resistors on pin LBI, the LBO output is pulled to logic low. LBO is working as Power-OK when LBI is connected to GND.

The AS1312 is available in a 8-pin (2x2) TDFN and a 0.4mm pitch 8-pin WL-CSP package.

*Ordering Information and Content Guide appear at end of datasheet.*

### Key Benefits & Features

The benefits and features of AS1312, Ultra Low Quiescent Current, Hysteretic DC-DC Step-up Converter are listed below:

**Figure 1:**  
Added Value of Using AS1312

Benefits	Features
Ideal for single Li-Ion battery powered applications	Wide Input Voltage Range (0.7V to 5.0V) Feedthrough mode when $V_{IN} > V_{OUT}$
Extended battery life	High Efficiency up to 94%
Less Power Consumption	Low Quiescent Current of typ. 1µA Low Shutdown Current of less than 100nA
Supports a variety of end applications	Fixed output voltage range (2.5V to 5.0V) Peak Output Current of 200mA Output Disconnect in shutdown

Benefits	Features
Over – temperature protection and shutdown	Integrated temperature monitoring
Early power-fail warning	Low battery detection
Cost effective, small package	8-pin WL-CSP with 0.4mm pitch 8-pin TDFN (2mm x 2mm)

### Applications

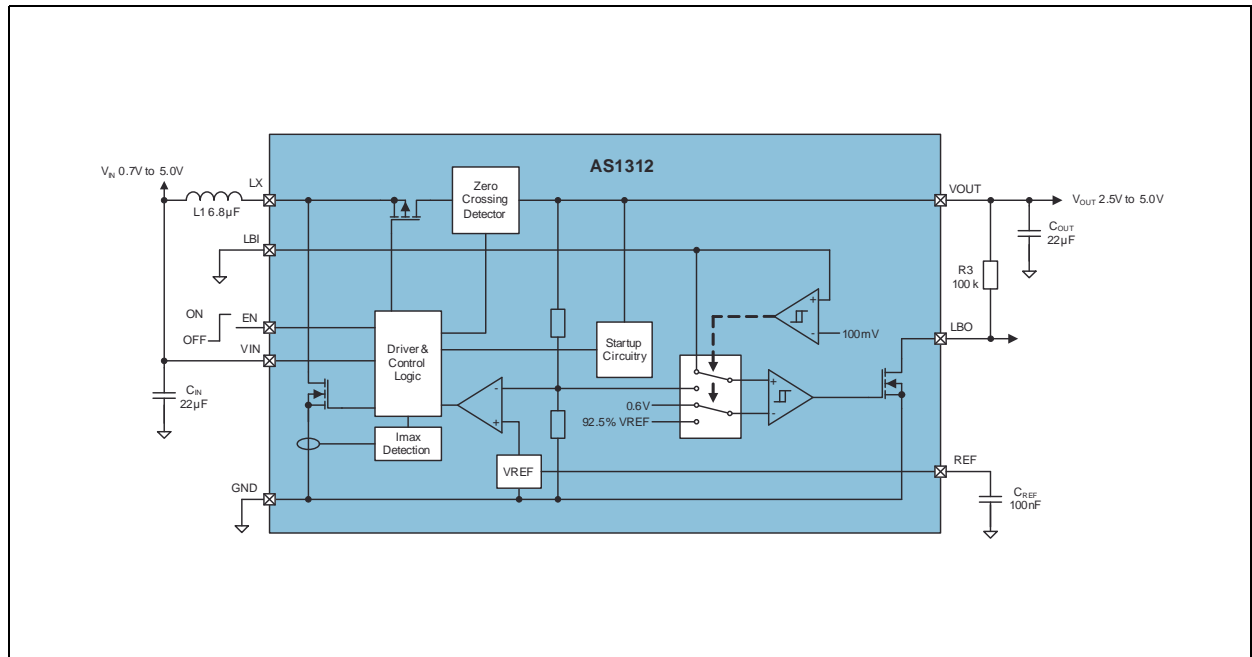
The AS1312 is an ideal solution for:

- Handheld devices
- Battery powered products

### Block Diagram

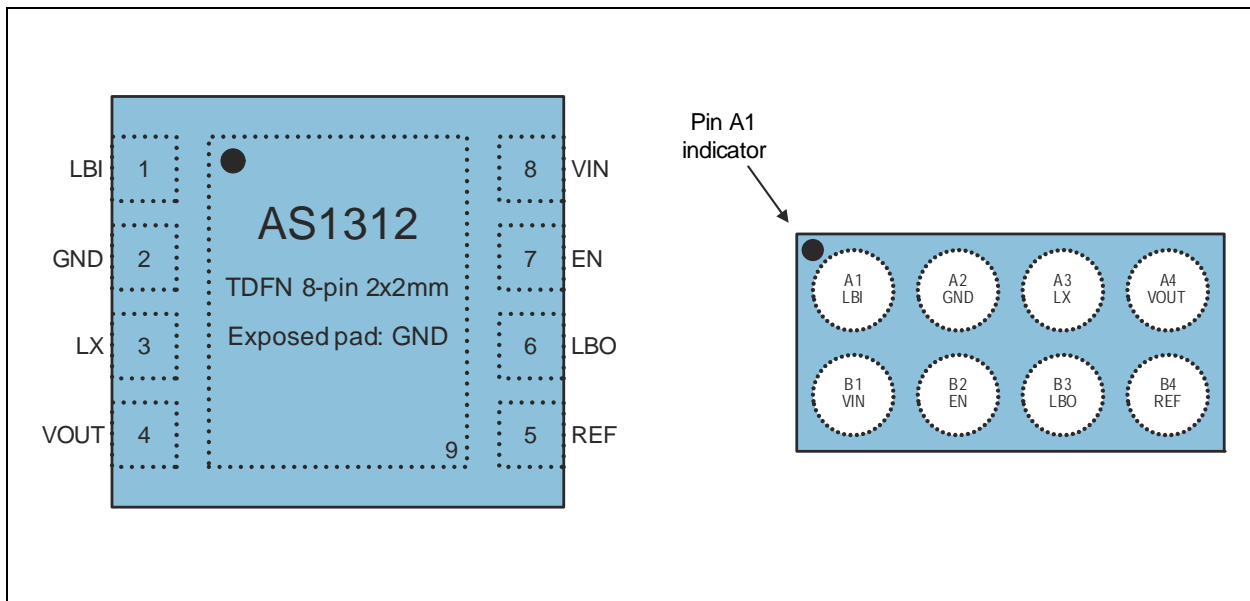
The functional blocks of this device for reference are shown below:

Figure 2:  
AS1312 Block Diagram



## Pin Assignments

**Figure 3:**  
Pinout (Top View)



**Figure 4:**  
Pin Description

Pin Number		Pin Name	Description
WL-CSP	TDFN		
A1	1	LBI	<b>Low Battery Comparator Input.</b> 0.6V Threshold. May not be left floating. If connected to GND, LBO is working as Power Output OK.
A2	2	GND	<b>Ground</b>
A3	3	LX	<b>External Inductor Connector.</b>
A4	4	VOUT	<b>Output Voltage.</b> Decouple VOUT with a ceramic capacitor as close as possible to VOUT and <b>GND</b> .
B4	5	REF	<b>Reference Pin.</b> Connect a 100nF ceramic capacitor to this pin.
B3	6	LBO	<b>Low Battery Comparator Output.</b> Open-drain output.
B2	7	EN	<b>Enable Pin.</b> Logic controlled shutdown input. 1 = Normal operation; 0 = Shutdown; shutdown current <100nA.
B1	8	VIN	<b>Battery Voltage Input.</b> Decouple VIN with a ceramic capacitor as close as possible to VIN and GND.
-	9	NC	<b>Exposed Pad.</b> This pad is not connected internally. Can be left floating or connect to <b>GND</b> to achieve an optimal thermal performance.

## Absolute Maximum Ratings

Stresses beyond those listed in Absolute Maximum Ratings may cause permanent damage to the device. These are stress ratings only, and functional operation of the device at these or any other conditions beyond those indicated in [Electrical Characteristics](#) is not implied. Exposure to absolute maximum rating conditions for extended periods may affect device reliability.

**Figure 5:**  
Absolute Maximum Ratings

Parameter		Min	Max	Unit	Comments	
<b>Electrical Parameters</b>						
VIN, VOUT, EN, LBI, LBO to GND		-0.3	7	V		
LX, REF to GND		-0.3	VOUT + 0.3	V		
Input Current (latch-up immunity)		-100	100	mA	Norm: JEDEC 78	
<b>Electrostatic Discharge</b>						
Electrostatic Discharge HBM		±2		kV	Norm: MIL 883 E method 3015	
<b>Temperature Ranges and Storage Conditions</b>						
$\theta_{JA}^{(1)}$	Thermal Resistance	WL-CSP	97	°C/W		
		TDFN	60			
$T_{AMB}$	Operating Temperature		-40	85	°C	
$T_J$	Junction Temperature	WL-CSP		125	°C	
		TDFN		150	°C	
	Storage Temperature Range		-55	150	°C	for 8-pin (2x2) TDFN
			-55	125	°C	for 8-pin WL-CSP
$T_{BODY}$	Package Body Temperature	WL-CSP		260	°C	Norm IPC/JEDEC J-STD-020 <sup>(2)</sup>
		TDFN				Norm IPC/JEDEC J-STD-020 <sup>(2)</sup> The lead for Pb-free leaded packages is matte tin (100% Sn)
Humidity non-condensing		5	85	%		

Parameter		Min	Max	Unit	Comments
	Moisture Sensitivity Level	WL-CSP	1		Represents an unlimited floor life time
		TDFN			Represents an unlimited floor life time

**Note(s) and/or Footnote(s):**

1. Junction-to-ambient thermal resistance is very dependent on application and board-layout. In situations where high maximum power dissipation exists, special attention must be paid to thermal dissipation during board design.
2. The reflow peak soldering temperature (body temperature) is specified according IPC/JEDEC J-STD-020 "Moisture/Reflow Sensitivity Classification for Nonhermetic Solid State Surface Mount Devices"

**Electrical Characteristics**

All limits are guaranteed. The parameters with Min and Max values are guaranteed by production tests or SQC (Statistical Quality Control) methods.

$V_{IN} = 1.5V$ ,  $C1 = C2 = 22\mu F$ ,  $C_{REF} = 100nF$ , Typical values are at  $T_{AMB} = 25^{\circ}C$ . Unless otherwise specified. All limits are guaranteed. The parameters with min and max values are guaranteed with production tests or SQC (Statistical Quality Control) methods.

**Figure 6:**  
Electrical Characteristics

Symbol	Parameter	Conditions	Min	Typ	Max	Unit
<b>Input</b>						
$V_{IN}$	Input Voltage Range		0.7		5.0	V
	Minimum Startup Voltage	$T_{AMB} = 25^{\circ}C$		0.9		V
<b>Regulation</b>						
$V_{OUT}$	Output Voltage Range		2.5		5.0	V
	Output Voltage Tolerance	$I_{LOAD} = 0mA$ to $10mA$ , $T_{AMB} = 25^{\circ}C$	-2		2	%
		$I_{LOAD} = 0mA$ to $10mA$	-4		4	%
		$I_{LOAD} = 0mA$ to $30mA$ , $T_{AMB} = -20^{\circ}C$ to $60^{\circ}C$	-2		2	%
	$V_{OUT}$ Lockout Threshold <sup>(1)</sup>	Rising Edge		2.45		V
<b>Operating Current</b>						
$I_Q$	Quiescent Current $V_{IN}$	$V_{OUT} = 1.02 \times V_{OUTNOM}$ , $REF = 0.99 \times V_{OUTNOM}$ , $T_{AMB} = 25^{\circ}C$			100	nA
	Quiescent Current $V_{OUT}$	$V_{OUT} = 5V$ , No load, $T_{AMB} = 25^{\circ}C$	0.7	1	1.3	$\mu A$
$I_{QSHDN}$	Shutdown Current	$T_{AMB} = 25^{\circ}C$			100	nA

Symbol	Parameter	Conditions	Min	Typ	Max	Unit
<b>Switches</b>						
RON	NMOS	VOUT = 5V		0.4		Ω
	PMOS			0.45		Ω
	NMOS maximum on-time		3.3	4.0	4.6	μs
IPEAK	Peak current limit			400		mA
	Zero crossing current		5	20	35	mA
<b>Enable, Reference</b>						
VENH	EN input voltage 'high'		0.7			V
VENL	EN input voltage 'low'				0.1	V
IEN	EN input bias current	EN = 5V, TAMB = 25°C			100	nA
IREF	REF input bias current	REF = 0.99xVOUTNOM, TAMB = 25°C			100	nA
<b>Low Battery &amp; Power-OK</b>						
VLBI	LBI threshold	Falling edge	0.57	0.6	0.63	V
	LBI hysteresis			25		mV
ILBI	LBI leakage current	LBI ≤ VIN or VOUT (which ever is higher), TAMB = 25°C			100	nA
VLBO	LBO voltage low <sup>(2)</sup>	ILBO = 1mA		5	20	mV
ILBO	LBO leakage current	TAMB = 25°C			100	nA
	Power-OK threshold	LBI = 0V, Falling Edge	87	91	95	%
<b>Thermal Protection</b>						
	Thermal shutdown <sup>(3)</sup>	10°C Hysteresis		150		°C

**Caution:** Do not apply full load current until the device output > 2.5V

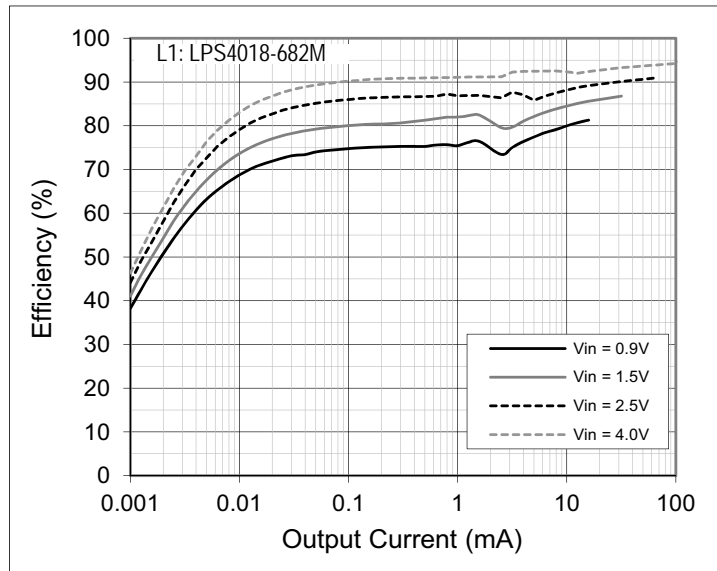
**Note(s) and/or Footnote(s):**

- The regulator is in startup mode until this voltage is reached.
- LBO goes low in startup mode as well as during normal operation if,
  - The voltage at the LBI pin is lower than LBI threshold.
  - The voltage at the LBI pin is below 0.1V (connected to GND) and VOUT is below 92.5% of its nominal value.
- Further switching is inhibited.

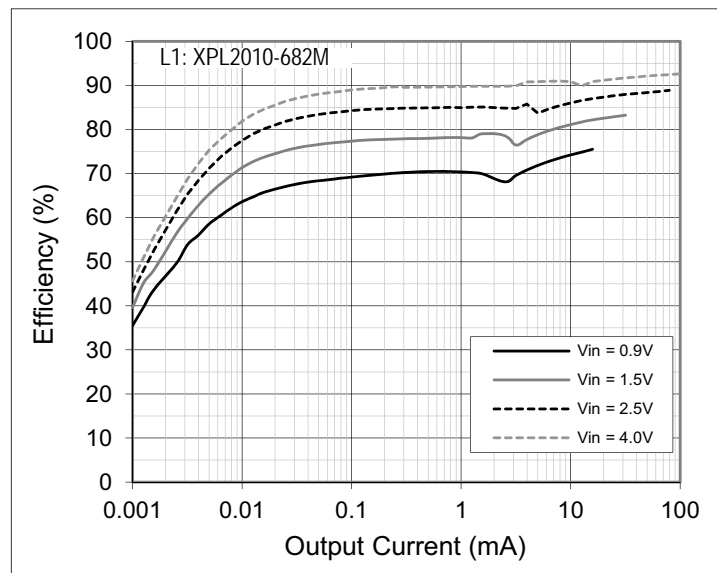
## Typical Operating Characteristics

$V_{OUT} = 5.0V$ ,  $T_{AMB} = 25^{\circ}C$ , unless otherwise specified.

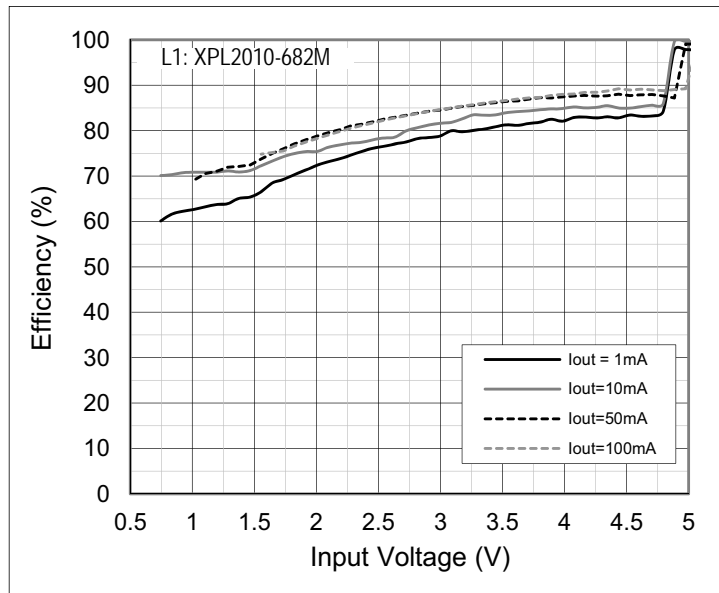
**Figure 7:**  
Efficiency vs. Output Current



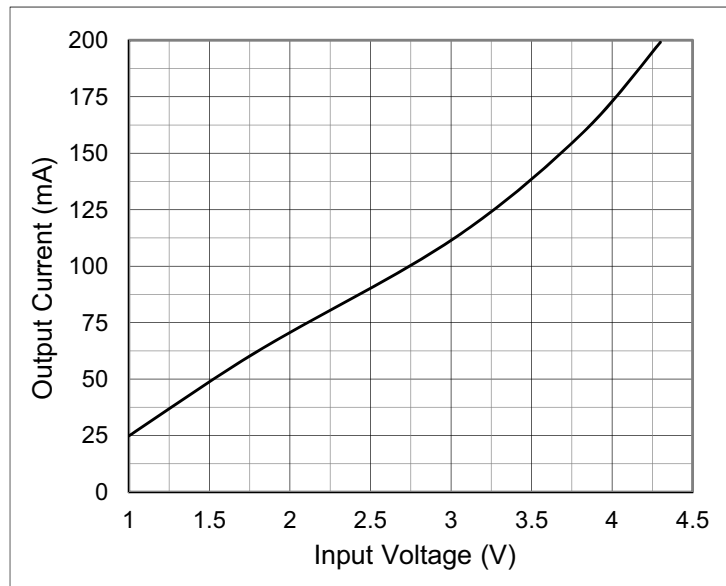
**Figure 8:**  
Efficiency vs. Output Current



**Figure 9:**  
Efficiency vs. Input Voltage

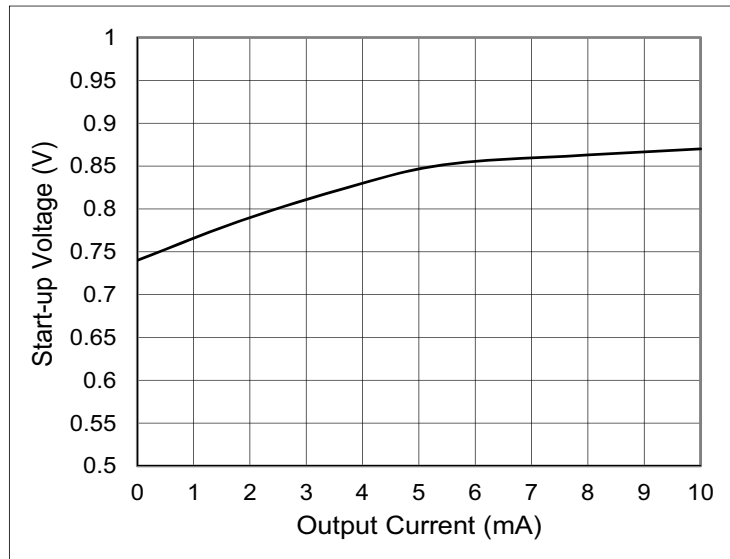


**Figure 10:**  
Maximum Output Current vs. Input Voltage

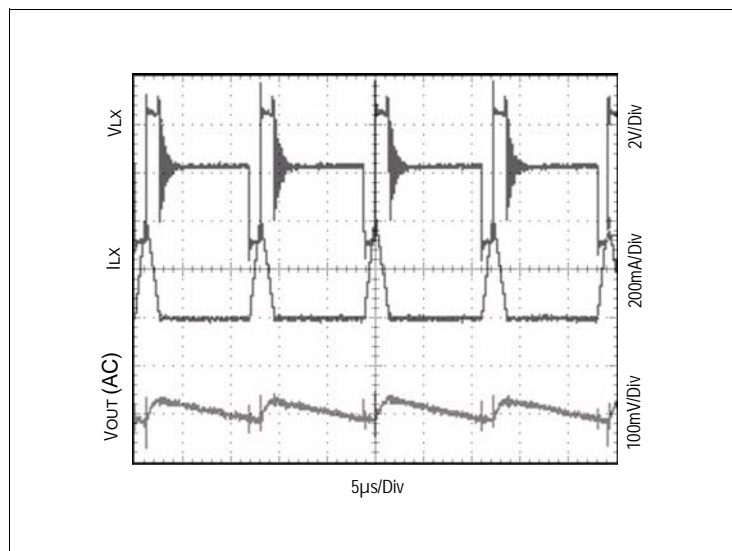




**Figure 11:**  
**Start-up Voltage vs. Output Current**



**Figure 12:**  
**Output Voltage Ripple;  $V_{IN} = 2V$ ,  $R_{load} = 100\Omega$**



## Detailed Description

### Hysteretic Boost Converter

Hysteretic boost converters are so called because comparators are the active elements used to determine on-off timing via current and voltage measurements. There is no continuously operating fixed oscillator, providing an independent timing reference. As a result, a hysteretic or comparator based converter has a very low quiescent current. In addition, because there is no fixed timing reference, the operating frequency is determined by external component (inductor and capacitors) and also the loading on the output.

Ripple at the output is an essential operating component. A power cycle is initiated when the output regulated voltage drops below the nominal value of  $V_{OUT}$  ( $0.99 \times V_{OUT}$ ).

Inductor current is monitored by the control loop, ensuring that operation is always dis-continuous.

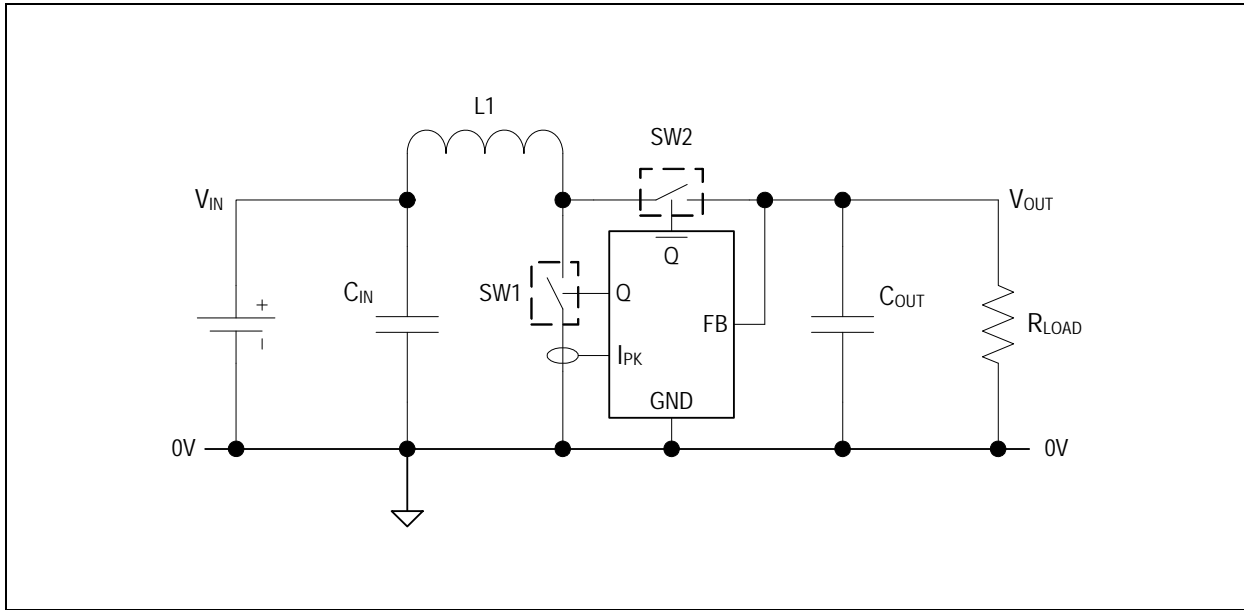
The application circuit shown in [Figure 15](#) will support many requirements. However, further optimization may be useful, and the following is offered as a guide to changing the passive components to more closely match the end requirement.

### *Input Loop Timing*

The input loop consists of the source dc supply, the input capacitor, the main inductor, and the N-channel power switch. The on timing of the N-channel switch is determined by a peak current measurement or a maximum on time. In the AS1312, peak current is 400mA (typ) and maximum on time is 4.2 $\mu$ s (typ). Peak current measurement ensures that the on time varies as the input voltage varies. This imparts line regulation to the converter.

The fixed on-time measurement is something of a safety feature to ensure that the power switch is never permanently on. The fixed on-time is independent of input voltage changes. As a result, no line regulation exists.

**Figure 13:**  
Simplified Boost DCDC Architecture



On time of the power switch (Faraday's Law) is given by:

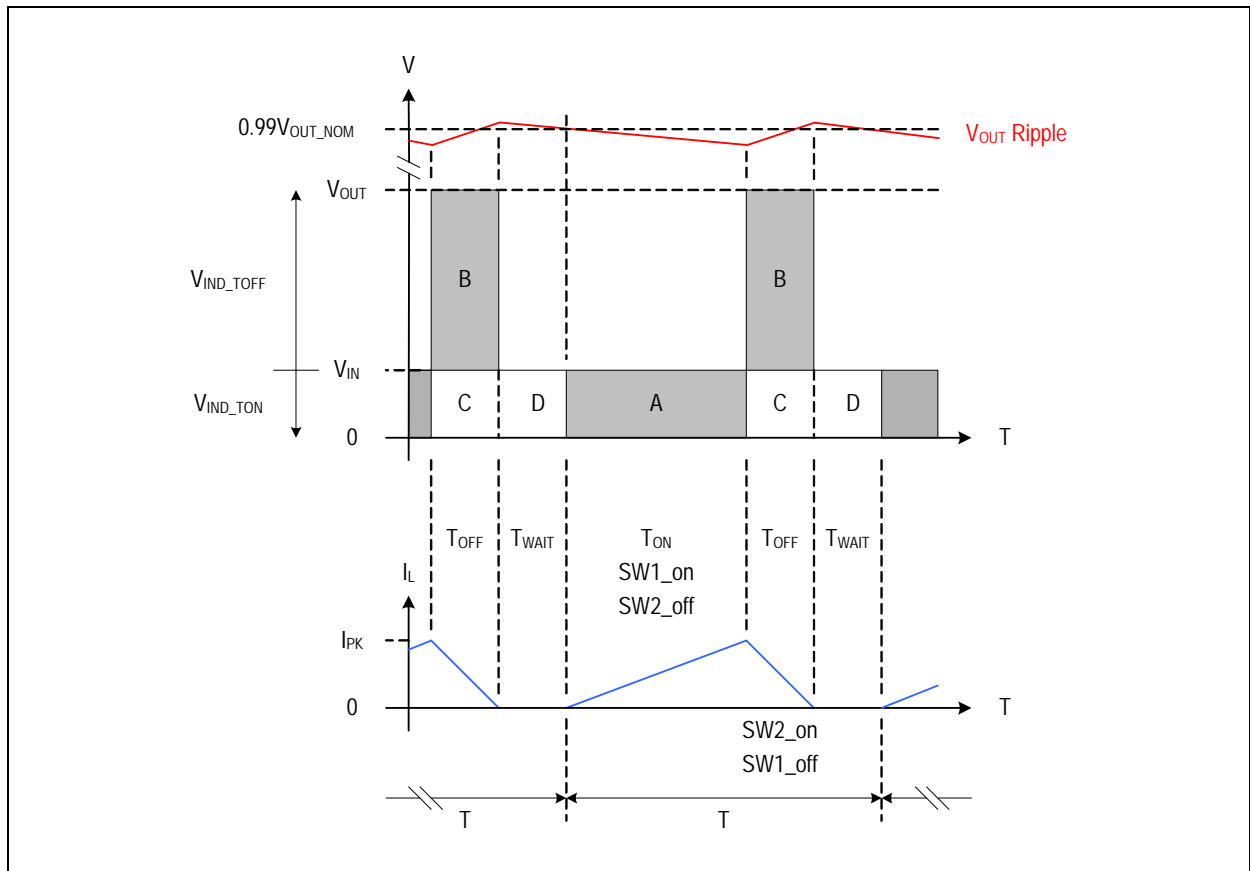
$$(EQ1) \quad T_{ON} = \frac{LI_{PK}}{V_{IN} - (I_{PK}R_{SW1} + I_{PK}R_{L1})} \text{ sec [volts, amps, ohms, Henry]}$$

Applying Min and Max values and neglecting the resistive voltage drop across L1 and SW1;

$$(EQ2) \quad T_{ON\_MIN} = \frac{L_{MIN} I_{PK\_MIN}}{V_{IN\_MAX}}$$

$$(EQ3) \quad T_{ON\_MAX} = \frac{L_{MAX} I_{PK\_MAX}}{V_{IN\_MIN}}$$

**Figure 14:**  
Simplified Voltage and Current Waveforms



Another important relationship is the “volt-seconds” law. Expressed as following:

$$(EQ4) \quad V_{ON}T_{ON} = V_{OFF}T_{OFF}$$

Voltages are those measured across the inductor during each time segment. Figure 14 shows this graphically with the shaded segments marked “A & B”. Re-arranging (EQ 4):

$$(EQ5) \quad \frac{T_{ON}}{T_{OFF}} = \frac{V_{OUT} - V_{IN}}{V_{IN}}$$

The time segment called  $T_{WAIT}$  in Figure 14 is a measure of the “hold-up” time of the output capacitor. While the output voltage is above the threshold ( $0.99 \times V_{OUT}$ ), the output is assumed to be in regulation and no further switching occurs.

**Inductor Choice Example**

For the AS1312  $V_{IN\_MIN} = 0.9V$ ,  $V_{OUT\_MAX} = 3.3V$ , (EQ 5) gives  $T_{ON} = 2.66T_{OFF}$ .

Let the maximum operating on-time =  $1\mu s$ .

Note that this is shorter than the minimum limit on-time of  $3.6\mu s$ . Therefore from (EQ 5),  $T_{OFF} = 0.376\mu s$ . Using (EQ 3),  $L_{MAX}$  is obtained:

$L_{MAX} = 1.875\mu H$ . The nearest preferred value is  $2.2\mu H$ .

This value provides the maximum energy storage for the chosen fixed on-time limit at the minimum  $V_{IN}$ .

Energy stored during the on time is given by:

$$(EQ6) \quad E = 0.5L(I_{PK})^2 \text{ Joules (Region A in Figure 14)}$$

If the overall time period ( $T_{ON} + T_{OFF}$ ) is  $T$ , the power taken from the input is:

$$(EQ7) \quad P_{IN} = \frac{0.5L(I_{PK})^2}{T} \text{ Watts}$$

Assume output power is  $0.8 P_{IN}$  to establish an initial value of operating period  $T$ .

$T_{WAIT}$  is determined by the time taken for the output voltage to fall to  $0.99 \times V_{OUT}$ . The longer the wait time, the lower will be the supply current of the converter. Longer wait times require increased output capacitance. Choose  $T_{WAIT} = 10\% T$  as a minimum starting point for maximum energy transfer. For very low power load applications, choose  $T_{WAIT} \geq 50\% T$ .

### Output Loop Timing

The output loop consists of the main inductor, P-channel synchronous switch (or diode if fitted), output capacitor and load. When the input loop is interrupted, the voltage on the LX pin rises (Lenz's Law). At the same time a comparator enables the synchronous switch, and energy stored in the inductor is transferred to the output capacitor and load. Inductor peak current supports the load and replenishes the charge lost from the output capacitor. The magnitude of the current from the inductor is monitored, and as it approaches zero, the synchronous switch is turned off. No switching action continues until the output voltage falls below the output reference point (0.99 x V<sub>OUT</sub>).

Output power is composed of the dc component (Region C in Figure 14):

$$(EQ8) \quad P_{REGION\_C} = V_{IN} \frac{I_{PK} T_{OFF}}{2T}$$

Output power is also composed of the inductor component (Region B in Figure 14), neglecting efficiency loss:

$$(EQ9) \quad P_{REGION\_B} = \frac{0.5L(I_{PK})^2}{T}$$

Total power delivered to the load is the sum of (EQ 8) and (EQ 9):

$$(EQ10) \quad P_{TOTAL} = V_{IN} \frac{I_{PK} T_{OFF}}{2T} + \frac{0.5L(I_{PK})^2}{T}$$

From (EQ 3) (using nominal values) peak current is given by:

$$(EQ11) \quad I_{PK} = \frac{T_{ON} V_{IN}}{L}$$

Substituting (EQ 11) into (EQ 10) and re-arranging:

$$(EQ12) \quad P_{TOTAL} = \frac{V_{IN}^2 T_{ON}}{2TL} (0.9T)$$

0.9T incorporates a wait time T<sub>WAIT</sub> = 10% T

Output power in terms of regulated output voltage and load resistance is:

$$(EQ13) \quad P_{OUT} = \frac{V_{OUT}^2}{R_{LOAD}}$$

Combining (EQ 12) and (EQ 13):

$$(EQ14) \quad \frac{V_{OUT}^2}{R_{LOAD}} = \frac{V_{IN}^2 T_{ON}}{2TL} (0.9T)\eta$$

Symbol  $\eta$  reflects total energy loss between input and output and is approximately 0.8 for these calculations. Use (EQ 14) to plot duty cycle ( $T_{ON}/T$ ) changes for various output loadings and changes to  $V_{IN}$ .

### **Input Capacitor Selection**

The input capacitor supports the triangular current during the on-time of the power switch, and maintains a broadly constant input voltage during this time. The capacitance value is obtained from choosing a ripple voltage during the on-time of the power switch. Additionally, ripple voltage is generated by the equivalent series resistance (ESR) of the capacitor. For worst case, use maximum peak current values from the datasheet.

$$(EQ15) \quad C_{IN} = \frac{I_{PEAK} T_{ON}}{V_{RIPPLE}}$$

Using  $T_{ON} = 1\mu s$ , and  $I_{PEAK} = 400mA$  (typ), and  $V_{RIPPLE} = 50mV$ , EQ 15 yields:

$$C_{IN} = 8.0\mu F$$

Nearest preferred would be 10 $\mu F$ .

$$(EQ16) \quad V_{PK\_RIPPLE\_ESR} = I_{PK} R_{ESR}$$

Typically, the ripple due to ESR is not dominant. ESR for the recommended capacitors (Murata GMR), ESR = 5m $\Omega$  to 10m $\Omega$ . For the AS1312, maximum peak current is 400mA. Ripple due to ESR is 2.0mV to 4.0mV.

Ripple at the input propagates through the common supply connections, and if too high in value can cause problems elsewhere in the system. The input capacitance is an important component to get right.

**Output Capacitor Selection**

The output capacitor supports the triangular current during the off-time of the power switch (inductor discharge period), and also the load current during the wait time (Region D in [Figure 14](#)) and on-time (Region A in [Figure 14](#)) of the power switch.

$$(EQ17) \quad C_{OUT} = \frac{I_{LOAD}(T_{ON} + T_{WAIT})}{(1 - 0.99)V_{OUT\_NOM}}$$

**Note(s):** There is also a ripple component due to the equivalent series resistance (ESR) of the capacitor.

**Summary****User Application Defines:**

$V_{INmin}$ ,  $V_{INmax}$ ,  $V_{OUTmin}$ ,  $V_{OUTmax}$ ,  $I_{LOADmin}$ ,  $I_{LOADmax}$

**Inductor Selection:**

Select Max on-time = 0.5 $\mu$ s to 3 $\mu$ s for AS1312. Use [\(EQ 3\)](#) to calculate inductor value.

Use [\(EQ 5\)](#) to determine off-time.

Use [\(EQ 6\)](#) to check that power delivery matches load requirements assume 70% conversion efficiency.

Use [\(EQ 13\)](#) to find overall timing period value of T at min  $V_{IN}$  and max  $V_{OUT}$  for maximum load conditions.

**Input Capacitor Selection:**

Choose a ripple value and use [\(EQ 14\)](#) to find the value.

**Output Capacitor Selection:**

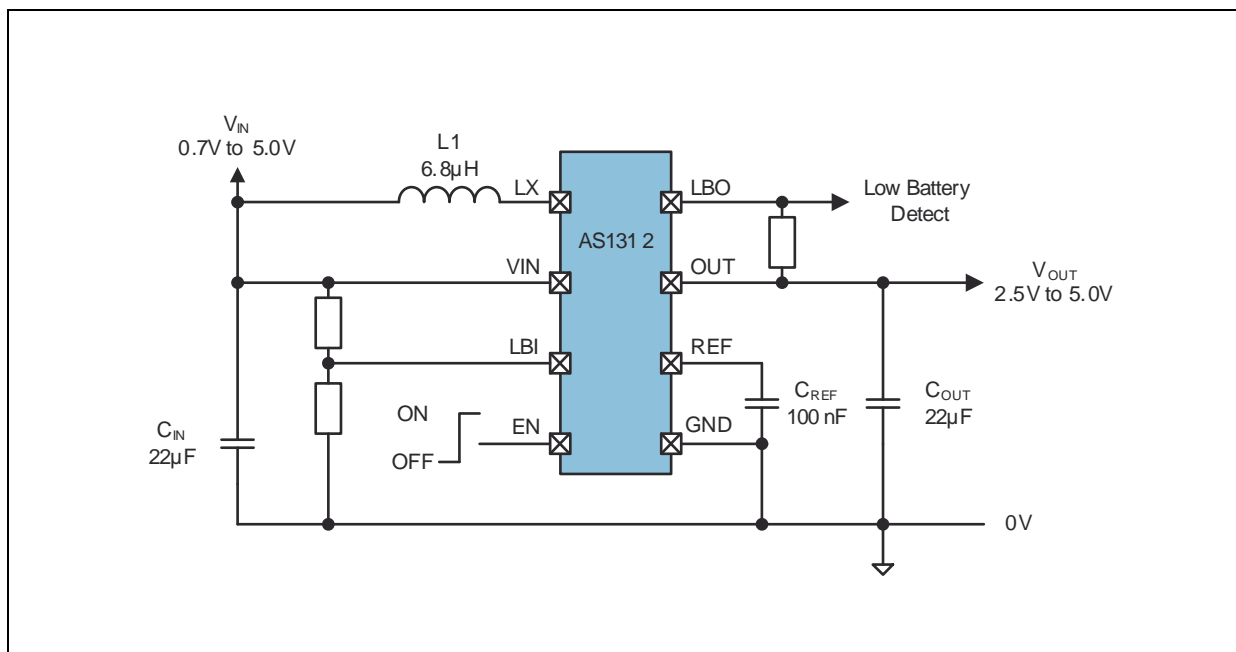
Determine  $T_{WAIT}$  via [\(EQ 6\)](#) or [\(EQ 13\)](#), and use [\(EQ 16\)](#) to find the value.



## Application Information

The AS1312 is available with fixed output voltages from 2.5V to 5.0V in 50mV steps.

**Figure 15:**  
Typical Application Diagram



## AS1312 Features

### Shutdown

The part is in shutdown mode while the voltage at pin EN is below 0.1V and is active when the voltage is higher than 0.7V.

**Note(s):** EN can be driven above VIN or VOUT, as long as it is limited to less than 5.0V.

### Output Disconnect

During shutdown VOUT is going to 0V and no current from the input source is running through the device.

### Feedthrough Mode

If the input voltage is higher than the output voltage (and the AS1312 is enabled) the supply voltage is connected to the load through the device. To guarantee a proper function of the AS1312 it is not allowed that the supply exceeds the maximum allowed input voltage (5.0V).

In this feedthrough mode the quiescent current is 35µA (typ.). The device goes back into step-up mode when the output voltage is 4% (typ.) below VOUTNOM.

### Power-OK and Low-Battery-Detect Functionality

LBO goes low in startup mode as well as during normal operation if:

- The voltage at the LBI pin is below LBI threshold (0.6V). This can be used to monitor the battery voltage.
- LBI pin is connected to GND and V<sub>OUT</sub> is below 92.5% of its nominal value. LBO works as a power-OK signal in this case.

The LBI pin can be connected to a resistive-divider to monitor a particular definable voltage and compare it with a 0.6V internal reference. If LBI is connected to GND an internal resistive-divider is activated and connected to the output. Therefore, the Power-OK functionality can be realized with no additional external components.

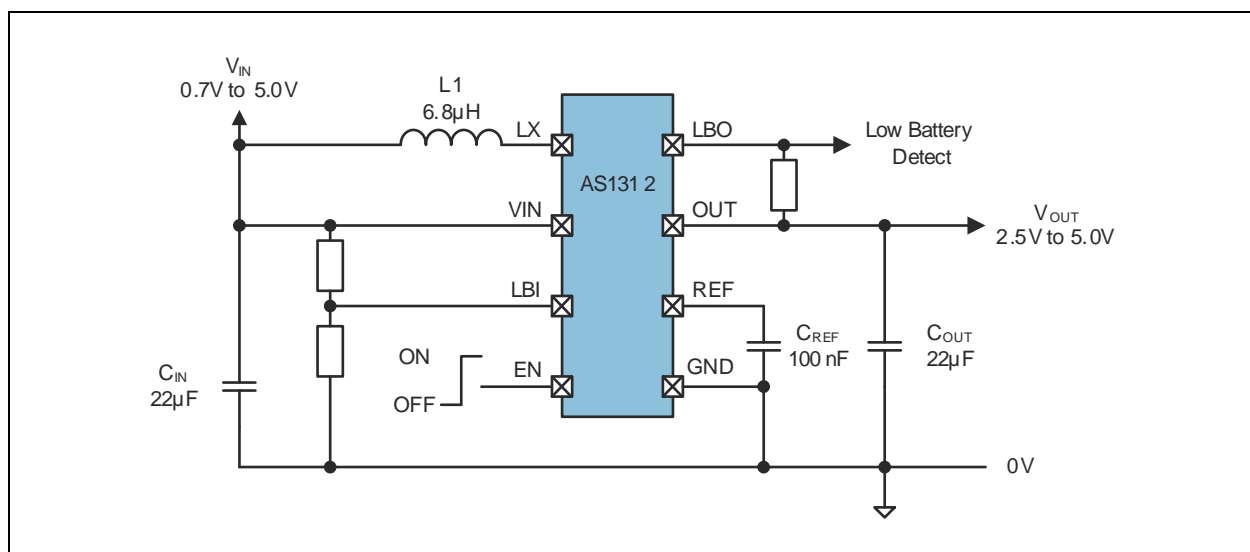
The Power-OK feature is not active during shutdown and provides a power-on-reset function that can operate down to V<sub>IN</sub> = 0.7V. A capacitor to GND may be added to generate a power-on-reset delay. To obtain a logic-level output, connect a pull-up resistor R<sub>3</sub> from pin LBO to pin V<sub>OUT</sub>. Larger values for this resistor will help to minimize current consumption; a 100kΩ resistor is perfect for most applications see [Figure 17](#).

For the circuit shown in the left of [Figure 16](#), the input bias current into LBI is very low, permitting large-value resistor-divider networks while maintaining accuracy. Place the resistor-divider network as close to the device as possible. Use a defined resistor for R<sub>2</sub> and then calculate R<sub>1</sub> as:

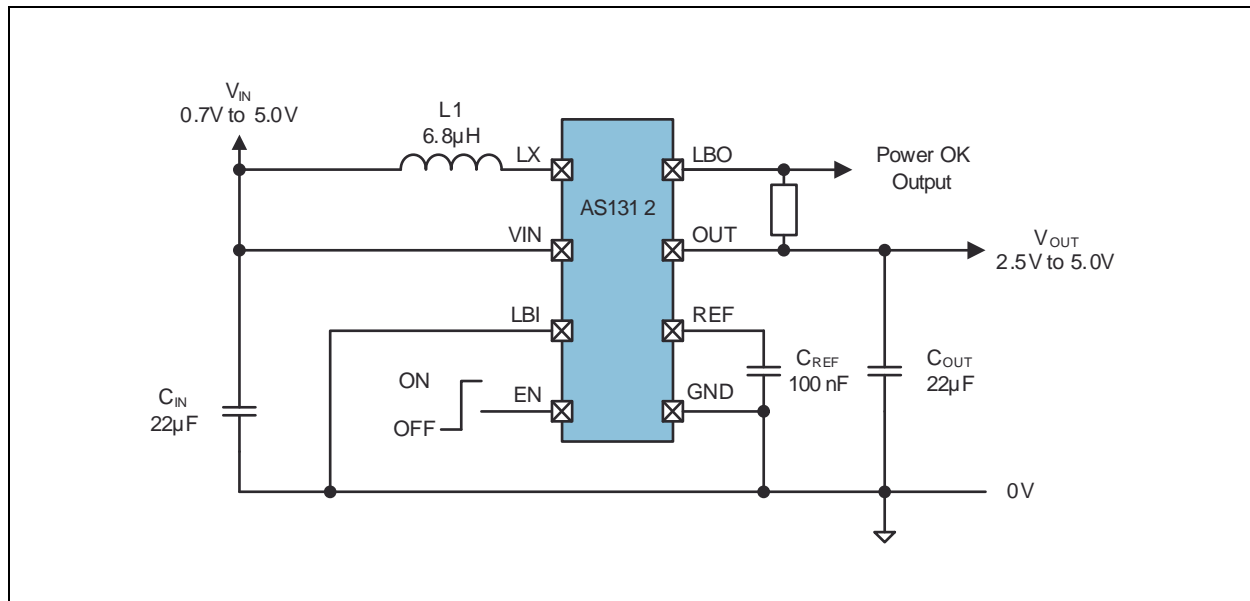
$$(EQ18) \quad R_1 = R_2 \cdot \left( \frac{V_{IN}}{V_{LBI}} - 1 \right)$$

Where: V<sub>LBI</sub> is 0.6V

**Figure 16:**  
Typical Application with Adjustable Battery Monitoring



**Figure 17:**  
**Typical Application with LBO Working as Power-OK**



### Thermal Shutdown

To prevent the AS1312 from short-term misuse and overload conditions the chip includes a thermal overload protection. To block the normal operation mode all further switching is inhibited for output voltage above  $V_{OUT}$  lockout threshold. The device is in thermal shutdown when the junction temperature exceeds  $150^{\circ}\text{C}$ . To resume the normal operation the temperature has to drop below  $140^{\circ}\text{C}$ .

A good thermal path has to be provided to dissipate the heat generated within the package. Otherwise it's not possible to operate the AS1312 at its usable maximal power. To dissipate as much heat as possible from the package into a copper plane with as much area as possible, it's recommended to use multiple vias in the printed circuit board. It's also recommended to solder the Exposed Pad (pin 9) to the GND plane.

**Note(s):** Continuing operation in thermal overload conditions may damage the device and is considered bad practice.

## Component Selection

Only four components are required to complete the design of the step-up converter. The low peak currents of the AS1312 allow the use of low value, low profile inductors and tiny external ceramic capacitors.

## Inductor Selection

For best efficiency, choose an inductor with high frequency core material, such as ferrite, to reduce core losses. The inductor should have low DCR (DC resistance) to reduce the  $I^2R$  losses, and must be able to handle the peak inductor current without saturating. A  $6.8\mu\text{H}$  inductor with a  $> 500\text{mA}$  current rating and  $< 500\text{m}\Omega$  DCR is recommended.

**Figure 18:**  
Recommended Inductors

Part Number	L	DCR	Current Rating	Size in mm (L/W/T)	Manufacturer
ELLVEG6R8N	6.8uH	0.35Ω	0.58A	3x3x1	Panasonic <a href="http://www.industrial.panasonic.com">www.industrial.panasonic.com</a>
ELLVFG6R8MC	6.8uH	0.23Ω	0.6A	3x3x1.2	
ELLVGG6R8N	6.8uH	0.23Ω	1A	3x3x1.5	
LQH3NPN6R8MM0	6.8uH	0.24Ω	1A	3x3x1.4	Murata <a href="http://www.murata.com">www.murata.com</a>
LQH3NPN6R8NM0	6.8uH	0.24Ω	1A	3x3x1.4	
LQH3NPN6R8MJ0	6.8uH	0.252Ω	0.85A	3x3x1.1	
LQH3NPN6R8NJ0	6.8uH	0.252Ω	0.85A	3x3x1.1	
LQH3NPN6R8MMR	6.8uH	0.186Ω	1.25A	3x3x1.1	
VLS2012ET-6R8M	6.8uH	0.498	0.57A	2x2x1.2	TDK <a href="http://www.tdk.com">www.tdk.com</a>
VLS252015ET-6R8M	6.8uH	0.48	0.85A	2.5x2x1.5	
VLS3010ET-6R8M	6.8uH	0.312	0.69A	3x3x1	
VLS3012ET-6R8M	6.8uH	0.228	0.81A	3x3x1.2	
VLS3015ET-6R8M	6.8uH	0.216	0.92A	3x3x1.5	
LPS4018-682ML	6.8uH	0.15	1.2A	4x4x1.7	Coilcraft <a href="http://www.coilcraft.com">www.coilcraft.com</a>

## Capacitor Selection

The convertor requires three capacitors. Ceramic X5R or X7R types will minimize ESL and ESR while maintaining capacitance at rated voltage over temperature. The VIN capacitor should be 22 $\mu$ F. The VOUT capacitor should be between 22 $\mu$ F and 47 $\mu$ F. A larger output capacitor should be used if lower peak to peak output voltage ripple is desired. A larger output capacitor will also improve load regulation on VOUT. See table below for a list of capacitors for input and output capacitor selection.

**Figure 19:**  
Recommended Input and Output Capacitors

Part Number	C	TC Code	Rated Voltage	Size in mm (L/W/T)	Manufacturer
GRM21BR60J226ME39L	22 $\mu$ F	X5R	6.3V	2x1.25x1.25	Murata <a href="http://www.murata.com">www.murata.com</a>
GRM31CR61A226ME19L	22 $\mu$ F	X5R	10V	3.2x1.6x1.6	
12066D226KAT_A	22 $\mu$ F	X5R	6.3V	3.2x1.6x1.78	AVX <a href="http://www.avx.com">www.avx.com</a>
1210ZD226KAT_A	22 $\mu$ F	X5R	10V	3.2x1.6x1.78	
1210YD226KAT_A	22 $\mu$ F	X5R	16V	3.2x1.6x1.78	
C2012X5R0J226K/1.25	22 $\mu$ F	X5R	6.3V	2x1.2x1.25	TDK <a href="http://www.tdk.com">www.tdk.com</a>
C2012X5R1A226K/1.25	22 $\mu$ F	X5R	10V	2x1.2x1.25	
C2012X5R1C226K	22 $\mu$ F	X5R	16V	2x1.2x1.25	

On the pin REF a 100nF capacitor with an Insulation resistance >1G $\Omega$  is recommended.

**Figure 20:**  
Recommended Capacitors for REF

Part Number	C	TC Code	Insulation Resistance	Rated Voltage	Dimensions (L/W/T)	Manufacturer
GRM188R71C104KA01	100nF	X7R	>5G $\Omega$	16V	0603, T=0.8mm	Murata <a href="http://www.murata.com">www.murata.com</a>

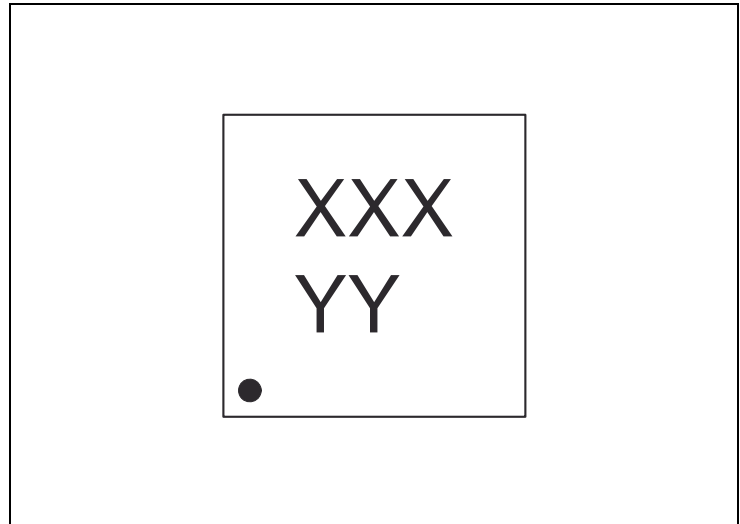
## Layout Considerations

Relatively high peak currents of 400mA (typ) circulate during normal operation of the AS1312. Long printed circuit tracks can generate additional ripple and noise that mask correct operation and prove difficult to “de-bug” during production testing. Referring to [Figure 15](#), the input loop formed by C1, VIN and GND pins should be minimized. Similarly, the output loop formed by C2, VOUT and GND should also be minimized. Ideally both loops should connect to GND in a “star” fashion. Finally, it is important to return CREF to the GND pin directly.

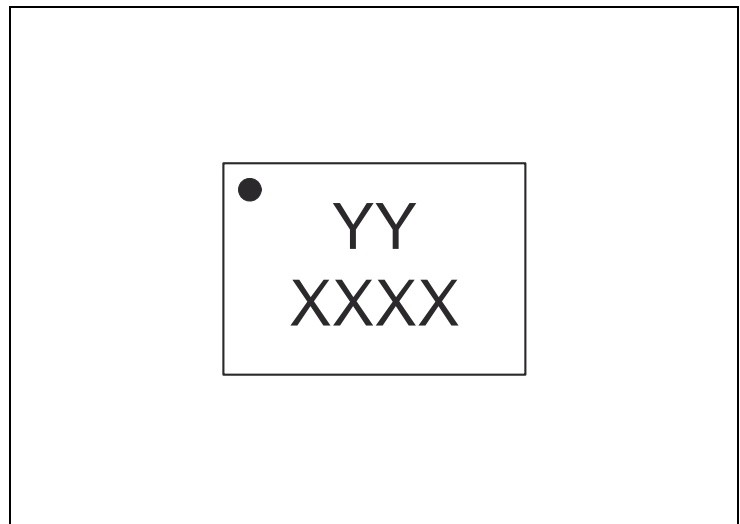
**Package Drawings & Markings**

The device is available in a 8-pin (2x2) TDFN and 8-pin WL-CSP package.

**Figure 21:  
8-pin (2x2) TDFN Marking**



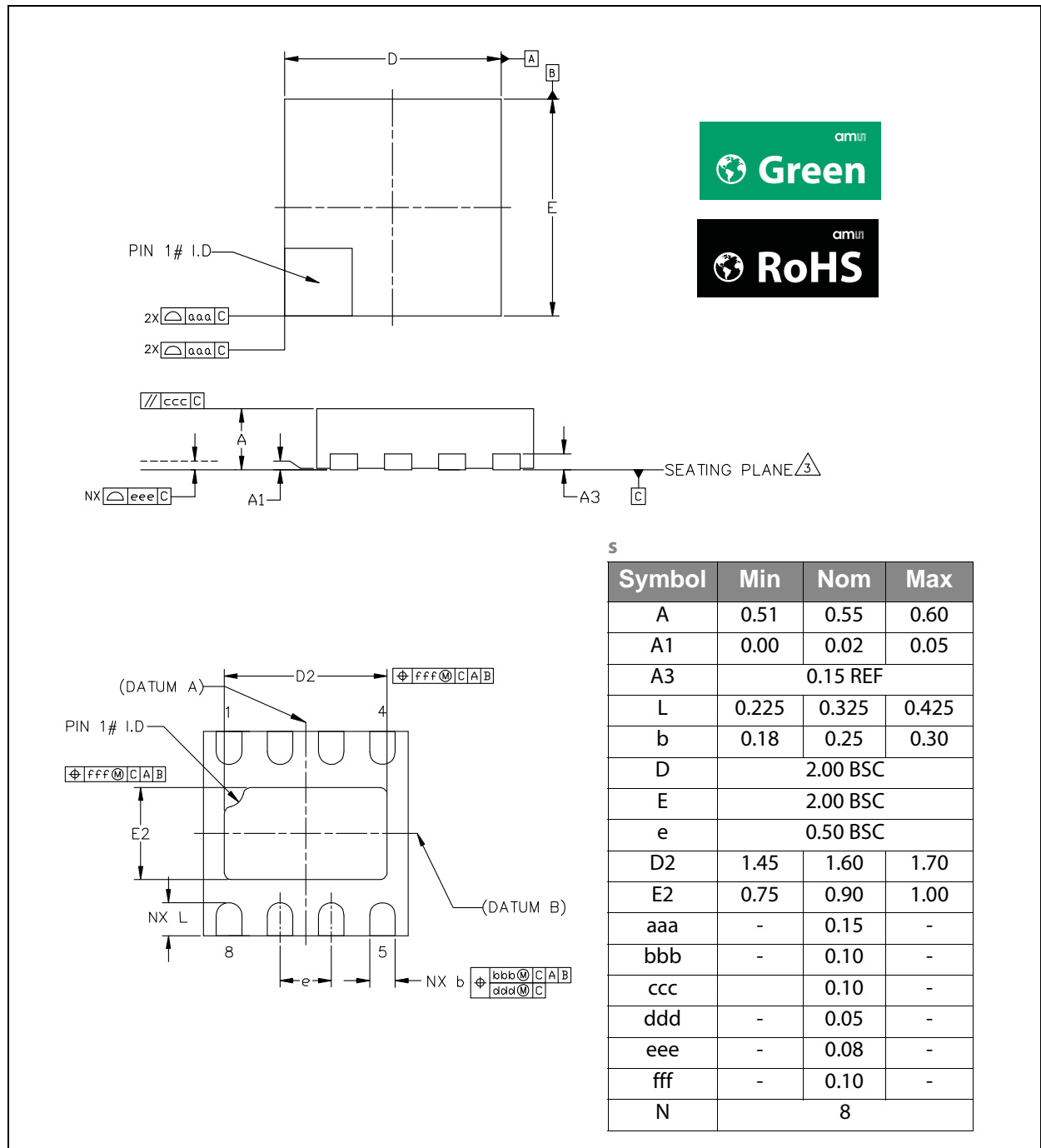
**Figure 22:  
8-pin WL-CSP Marking**



**Figure 23:  
Packaging Code**

XXX	XXXX	YY
Tracecode for TDFN	Tracecode for WL-CSP	Marking

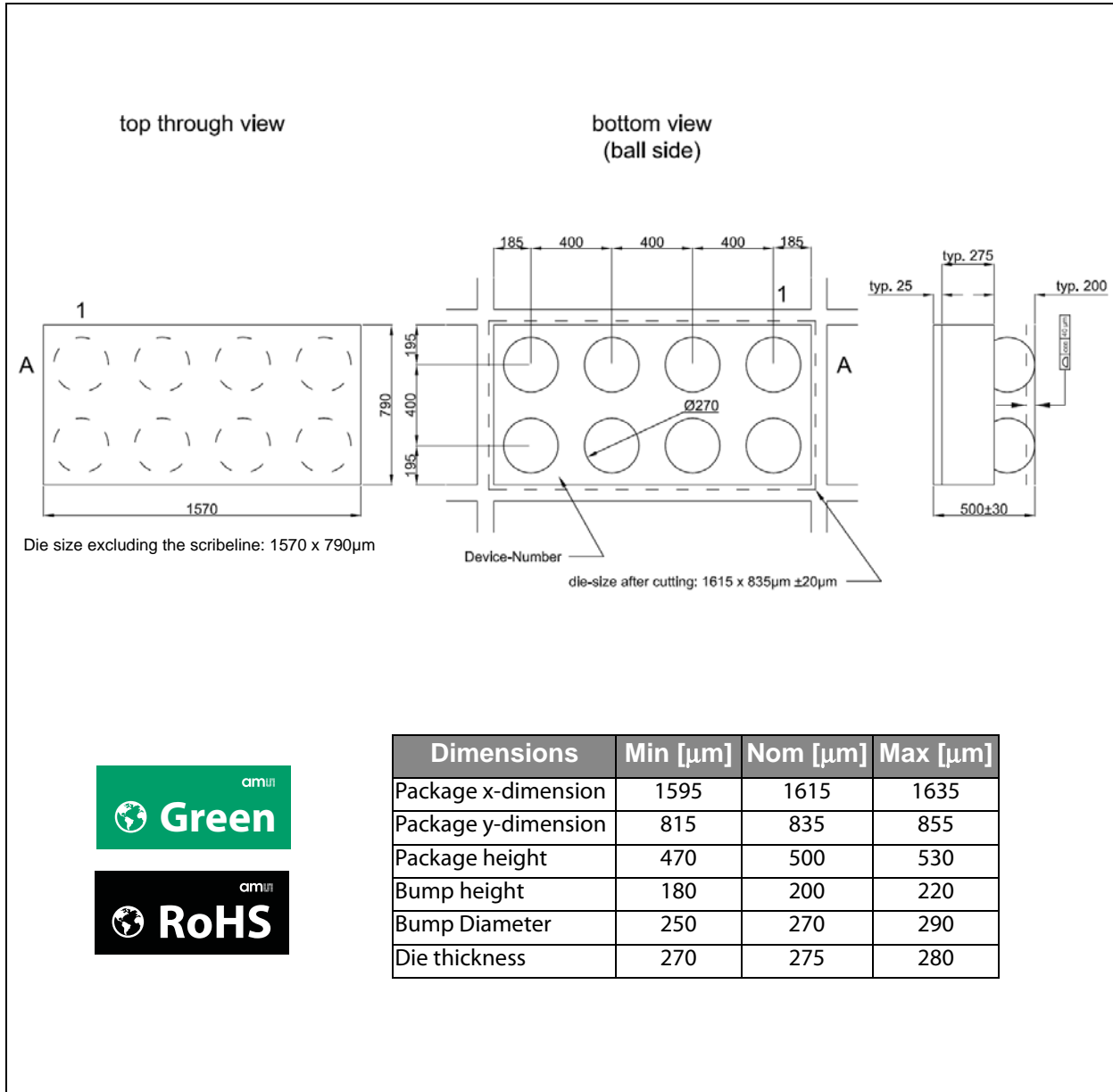
**Figure 24:**  
8-pin (2x2) TDFN Drawings and Dimensions



**Note(s) and/or Footnote(s):**

1. Dimensioning & tolerancing conform to ASME Y14.5M-1994.
2. All dimensions are in millimeters. Angles are in degrees.
3. Coplanarity applies to the exposed heat slug as well as the terminal.
4. Radius on terminal is optional.
5. N is the total number of terminals.

**Figure 25:**  
8-pin WL-CSP Drawings and Dimensions



**Note(s) and/or Footnote(s):**

1. ccc Coplanarity.
2. All dimensions are in µm.
3. "Bottom view" and "top trough view" values indicate the die dimensions without scribe lines. The "die size after cutting" values gives the package dimensions with tolerance.



## Ordering & Contact Information

The device is available as the standard products listed below.

**Figure 26:**  
Ordering Information

Ordering Code	Marking	V <sub>OUT</sub>	Description	Delivery Form	Package
AS1312-BTDT-50	BE	5.0V	Ultra Low Quiescent Current, Hysteretic DC-DC Step-up Converter	Tape and Reel	8-pin (2x2) TDFN
AS1312-BTDT-33	BX	3.3V		Tape and Reel	8-pin (2x2) TDFN
AS1312-BTDT-30	BY	3.0V		Tape and Reel	8-pin (2x2) TDFN
AS1312-BTDM-27	C1	2.7V		Tape and Reel	8-pin (2x2) TDFN
AS1312-BWLT-50	BF	5.0V		Tape and Reel	8-pin WL-CSP
AS1312-BWLT-45	BQ	4.5V		Tape and Reel	8-pin WL-CSP
AS1312-BWLT-33	CO	3.3V		Tape and Reel	8-pin WL-CSP
AS1312 <sup>(1)</sup>	tbd	xx		Tape and Reel	tbd

**Note(s) and/or Footnote(s):**

1. Non-standard devices from 2.5V to 5.0V are available in 50mV steps.

The above figure shows the ordering codes for Tape & Reel deliveries (suffix **T** in the ordering code). It is also possible to have all the variants on mini reels, when the ordering codes are AS1312-BTDM-xx or AS1312-BWLM (where suffix **M** stands for mini reel). The components are the same in both reel sizes.

Buy our products or get free samples online at:

[www.ams.com/ICdirect](http://www.ams.com/ICdirect)

Technical Support is available at:

[www.ams.com/Technical-Support](http://www.ams.com/Technical-Support)

Provide feedback about this document at:

[www.ams.com/Document-Feedback](http://www.ams.com/Document-Feedback)

For further information and requests, e-mail us at:

[ams\\_sales@ams.com](mailto:ams_sales@ams.com)

For sales offices, distributors and representatives, please visit:

[www.ams.com/contact](http://www.ams.com/contact)

### Headquarters

ams AG  
Tobelbaderstrasse 30  
8141 Unterpremstaetten  
Austria, Europe

Tel: +43 (0) 3136 500 0

Website: [www.ams.com](http://www.ams.com)

## RoHS Compliant & ams Green Statement

**RoHS:** The term RoHS compliant means that ams AG products fully comply with current RoHS directives. Our semiconductor products do not contain any chemicals for all 6 substance categories, including the requirement that lead not exceed 0.1% by weight in homogeneous materials. Where designed to be soldered at high temperatures, RoHS compliant products are suitable for use in specified lead-free processes.

**ams Green (RoHS compliant and no Sb/Br):** ams Green defines that in addition to RoHS compliance, our products are free of Bromine (Br) and Antimony (Sb) based flame retardants (Br or Sb do not exceed 0.1% by weight in homogeneous material).

**Important Information:** The information provided in this statement represents ams AG knowledge and belief as of the date that it is provided. ams AG bases its knowledge and belief on information provided by third parties, and makes no representation or warranty as to the accuracy of such information. Efforts are underway to better integrate information from third parties. ams AG has taken and continues to take reasonable steps to provide representative and accurate information but may not have conducted destructive testing or chemical analysis on incoming materials and chemicals. ams AG and ams AG suppliers consider certain information to be proprietary, and thus CAS numbers and other limited information may not be available for release.

## Copyrights & Disclaimer

Copyright ams AG, Tobelbader Strasse 30, 8141 Unterpremstaetten, Austria-Europe. Trademarks Registered. All rights reserved. The material herein may not be reproduced, adapted, merged, translated, stored, or used without the prior written consent of the copyright owner.

Devices sold by ams AG are covered by the warranty and patent indemnification provisions appearing in its General Terms of Trade. ams AG makes no warranty, express, statutory, implied, or by description regarding the information set forth herein. ams AG reserves the right to change specifications and prices at any time and without notice. Therefore, prior to designing this product into a system, it is necessary to check with ams AG for current information. This product is intended for use in commercial applications. Applications requiring extended temperature range, unusual environmental requirements, or high reliability applications, such as military, medical life-support or life-sustaining equipment are specifically not recommended without additional processing by ams AG for each application. This product is provided by ams AG "AS IS" and any express or implied warranties, including, but not limited to the implied warranties of merchantability and fitness for a particular purpose are disclaimed.

ams AG shall not be liable to recipient or any third party for any damages, including but not limited to personal injury, property damage, loss of profits, loss of use, interruption of business or indirect, special, incidental or consequential damages, of any kind, in connection with or arising out of the furnishing, performance or use of the technical data herein. No obligation or liability to recipient or any third party shall arise or flow out of ams AG rendering of technical or other services.

## Document Status

Document Status	Product Status	Definition
Product Preview	Pre-Development	Information in this datasheet is based on product ideas in the planning phase of development. All specifications are design goals without any warranty and are subject to change without notice
Preliminary Datasheet	Pre-Production	Information in this datasheet is based on products in the design, validation or qualification phase of development. The performance and parameters shown in this document are preliminary without any warranty and are subject to change without notice
Datasheet	Production	Information in this datasheet is based on products in ramp-up to full production or full production which conform to specifications in accordance with the terms of ams AG standard warranty as given in the General Terms of Trade
Datasheet (discontinued)	Discontinued	Information in this datasheet is based on products which conform to specifications in accordance with the terms of ams AG standard warranty as given in the General Terms of Trade, but these products have been superseded and should not be used for new designs

## Revision Information

Changes from 1-16 (2014-Sep-01) to current revision 1-18 (2014-Dec-15)	Page
Updated Package Drawings & Markings section	24

**Note(s) and/or Footnote(s):**

1. Page and figure numbers for the previous version may differ from page and figure numbers in the current revision.
2. Correction of typographical errors is not explicitly mentioned.

**Content Guide**

<b>1</b>	<b>General Description</b>
1	Key Benefits & Features
2	Applications
2	Block Diagram
<b>3</b>	<b>Pin Assignments</b>
<b>4</b>	<b>Absolute Maximum Ratings</b>
<b>5</b>	<b>Electrical Characteristics</b>
<b>7</b>	<b>Typical Operating Characteristics</b>
<b>10</b>	<b>Detailed Description</b>
10	Hysteretic Boost Converter
10	Input Loop Timing
13	Inductor Choice Example
14	Output Loop Timing
15	Input Capacitor Selection
16	Output Capacitor Selection
16	Summary
<b>17</b>	<b>Application Information</b>
17	AS1312 Features
17	Shutdown
17	Output Disconnect
17	Feedthrough Mode
18	Power-OK and Low-Battery-Detect Functionality
19	Thermal Shutdown
20	Component Selection
20	Inductor Selection
21	Capacitor Selection
21	Layout Considerations
<b>22</b>	<b>Package Drawings &amp; Markings</b>
<b>25</b>	<b>Ordering &amp; Contact Information</b>
<b>26</b>	<b>RoHS Compliant &amp; ams Green Statement</b>
<b>27</b>	<b>Copyrights &amp; Disclaimer</b>
<b>28</b>	<b>Document Status</b>
<b>29</b>	<b>Revision Information</b>