

AS1355 300mA, Triple LDO

1 General Description

The AS1355 is a high-performance triple CMOS low-dropout voltage regulator in a single QFN package. The efficient set of programmable power supplies is optimized to deliver the best compromise between quiescent current and regulator performance for mobile phones, PDAs, MP3 players, and other battery powered devices.

Stability is guaranteed with ceramic output capacitors of only 1 μ F ($\pm 20\%$ – X5R) up to 4.7 μ F ($\pm 20\%$ – X5R). The low equivalent series resistance (ESR) of these capacitors ensures low output impedance at high frequencies.

Regulation performance is excellent even under low dropout conditions, when the power transistor has to operate in linear mode.

The low-noise performance allows direct connection of noise sensitive circuits without additional filtering networks.

The AS1355 is available in a 16-pin QFN 3x3 package.

2 Key Features

- 3 Independent Voltage Regulators with Shutdown
- Output Current: 300mA each LDO
- Programmable Output Voltage Range: 1.25V to 3.6V in 50mV Steps
- Accuracy: $\pm 1.0\%$
- PSRR: 70dB at 1kHz, 60dB at 100kHz
- Line Regulation: $\pm 2\text{mV}$
- Load Regulation: $\pm 0.6\text{mV}$
- Supply Range: 2.3V to 5.5V
- 0.1V Dropout Voltage @ Iload = 200mA
- Shutdown Current: $\leq 1\mu\text{A}$
- Supply Current Without Load: 160 μA (typ)
- Softstart for Low Inrush Current
- Stable with low ESR Ceramic Capacitors from 1 μF to 4.7 μF
- Low Noise: 40 μV rms @ 10Hz to 100kHz Bandwidth
- Thermal Protection
- Over-Current Protection
- Temperature Range: -40°C to +85°C
- 16-pin QFN 3x3 Package

3 Applications

The AS1355 is ideal for cordless and mobile phones, MP3 players, CD and DVD players, PDAs, hand-held computers, digital cameras, and any other hand-held battery-powered device.

Figure 1. AS1355 - Typical Application Diagram

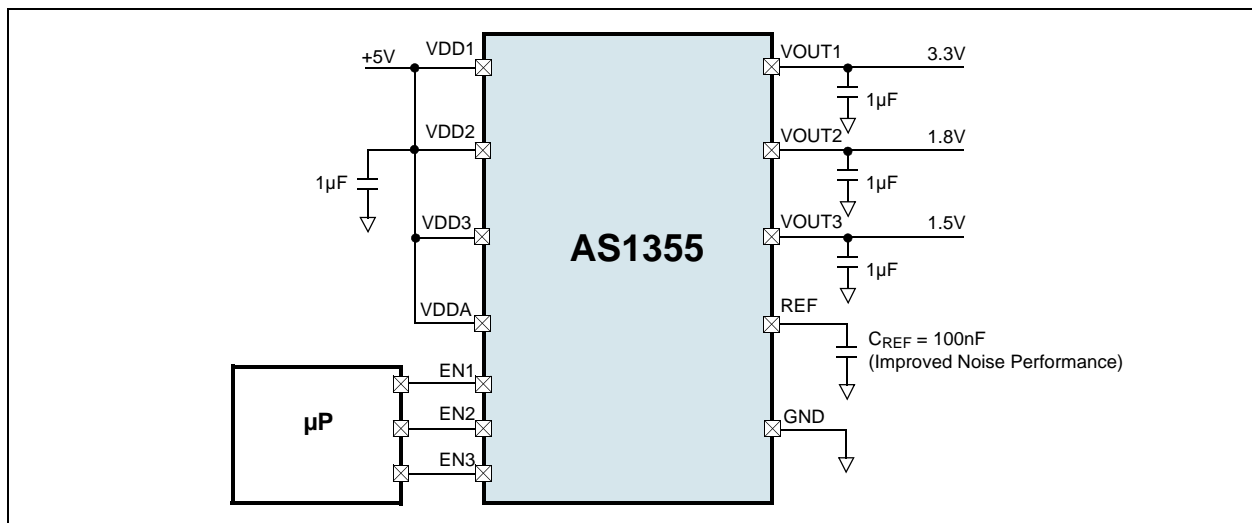

4 Pinout

Pin Assignments

Figure 2. Pin Assignments (Top View)

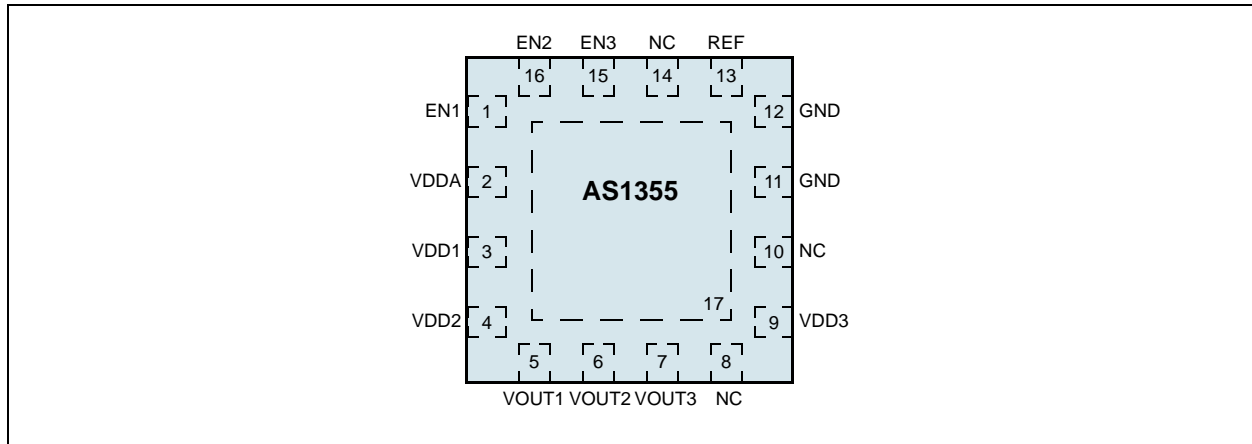

Pin Descriptions

Table 1. Pin Descriptions

Pin Number	Pin Name	Description
1	EN1	Active-High Enabel Input 1. Pull this pin to low to disable the regulated output voltage V_{OUT1} .
2	VDDA	Analog Power Supply Voltage
3	VDD1	Unregulated Input Voltage 1
4	VDD2	Unregulated Input Voltage 2
5	VOUT1	Regulated Output Voltage 1
6	VOUT2	Regulated Output Voltage 2
7	VOUT3	Regulated Output Voltage 3
8	NC	Not Connected
9	VDD3	Unregulated Input Voltage 3
10	NC	Not Connected
11, 12	GND	Ground. Note: All GND pins must be connected together externally.
13	REF	Reference Voltage. Note: Connect to a 100nF capacitor during normal operation.
14	NC	Not Connected
15	EN3	Active-High Enabel Input 3. Pull this pin to low to disable the regulated output voltage V_{OUT3} .
16	EN2	Active-High Enabel Input 2. Pull this pin to low to disable the regulated output voltage V_{OUT2} .
17	NC	Exposed Pad. This pad is not connected internally, it can be connected to GND.

5 Absolute Maximum Ratings

Stresses beyond those listed in Table 2 may cause permanent damage to the device. These are stress ratings only, and functional operation of the device at these or any other conditions beyond those indicated in the operational sections of the specifications is not implied. Exposure to absolute maximum rating conditions for extended periods may affect device reliability.

Table 2. Absolute Maximum Ratings

Parameter	Min	Max	Units	Comments
ENx, VDDx to GND	-0.3	7	V	
VOUTx to GND	-0.3	5	V	
Any other pin to GND	-0.3	VDD + 0.3	V	
Thermal Resistance Θ_{JA}		33	°C/W	on PCB
Package-Body Peak Temperature		260	°C	The reflow peak soldering temperature (body temperature) specified is in accordance with <i>IPC/JEDEC J-STD-020D "Moisture/Reflow Sensitivity Classification for non-hermetic Solid State Surface Mount Devices"</i> .
Operating Temperature	-40	85	°C	
Storage Temperature	-65	150	°C	
Electrostatic Discharge Protection (ESD) Level	2		kV	HBM – Norm: <i>MIL 883 E method 3015</i> .

6 Electrical Characteristics

$V_{DD} = 4V$, $C_{OUT} = 1\mu F$, $T_{AMB} = -40^{\circ}C$ to $+85^{\circ}C$ (Typ values are for $T_{AMB} = 25^{\circ}C$), unless otherwise specified;

Table 3. Electrical Characteristics

Symbol	Parameter	Conditions	Min	Typ	Max	Unit
V _{DD}	Supply Voltage Range		2.3		5.5	V
V _{OUT}	Output Voltage Range		1.25		3.6	V
R _{ON}	On Resistance			0.5	1	Ω
PSRR ¹	Power Supply Rejection Ratio	f = 1kHz, C _{REF} = 100nF		70		dB
		f = 100kHz, C _{REF} = 100nF		60		
I _{OFF}	Shut Down Current	EN _x = Low, T _{AMB} = +25°C			1	μA
I _{VDD}	Supply Current	Without Load		160	240	μA
t _{set} ¹	Output Voltage Settling Time	I _{LOAD} Switched from 0 to 100mA			50	μs
t _{start} ¹	Start-up Time ²	C _{REF} = 100nF Pre-charged			300	μs
		C _{REF} = 0nF Uncharged		200		μs
		C _{REF} = 100nF Uncharged		15		ms
V _{OUT}	Output Voltage Tolerance	I _{LOAD} = 0mA, T _{AMB} = 25°C	-1		1	%
		I _{LOAD} = 0 to 300mA	-2		2	%
V _{LINEREG}	Line Regulation, Static	V _{OUT(NOM)} +0.3V to 5.5V	-1		1	%
V _{LOADREG}	Load Regulation, Static	I _{LOAD} = 0 to 50 mA		0.5	2.5	mV ¹
		I _{LOAD} = 0 to 300 mA		3	10	mV ¹
V _{IH}	Enable Input Voltage High		1.5			V
V _{IL}	Enable Input Voltage Low				0.4	V
I _{LOAD}	Output Current		0		300	mA
I _{LIMIT}	Output Current Limitation			450		mA
V _{Noise}	Output Noise Voltage	10Hz to 100kHz, C _{REF} = 100nF		40		μV _{RMS}
	Thermal Protection			150		°C

1. Guaranteed by design and verified by lab evaluation.

2. Startup is performed if any EN pin goes high.

Note: All limits are guaranteed. The parameters with min and max values are guaranteed with production tests or SQC (Statistical Quality Control) methods.

7 Typical Operating Characteristics

VDD = 4V, VOUT = 3.3V, COUT = 1μF, TAMB = +25°C (unless otherwise specified);

Figure 3. Load Regulation; VOUT vs. IOUT

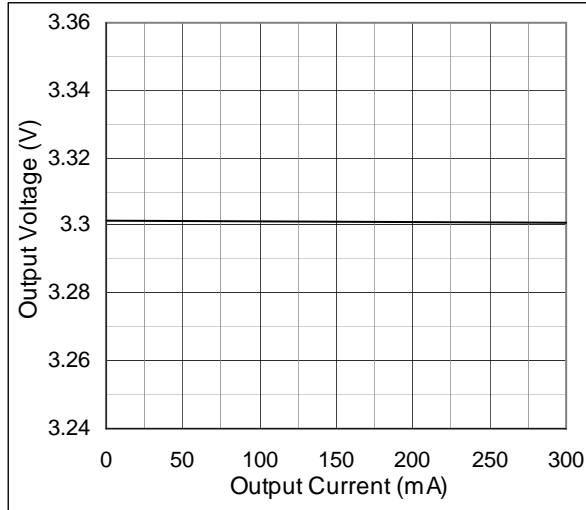

Figure 4. Line Regulation; VOUT vs. VIN

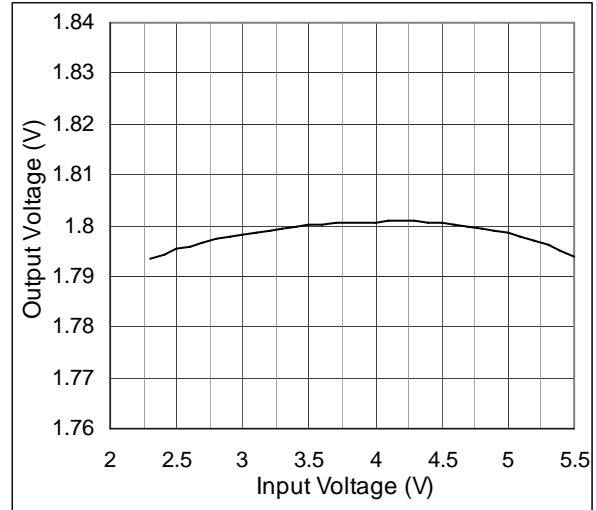

Figure 5. Output Voltage vs. Temp.; IOUT = 1mA

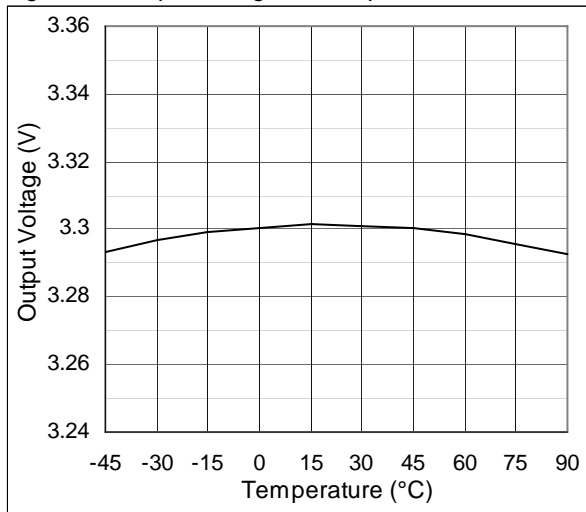

Figure 6. Quiescent Current vs. Temperature

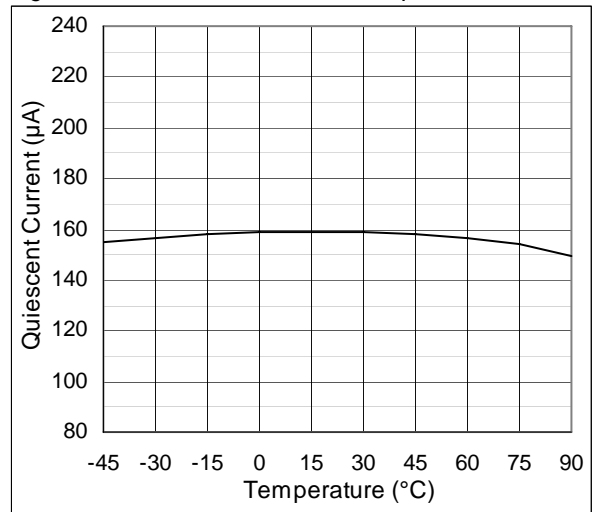

Figure 7. Startup; no Load, no CREF

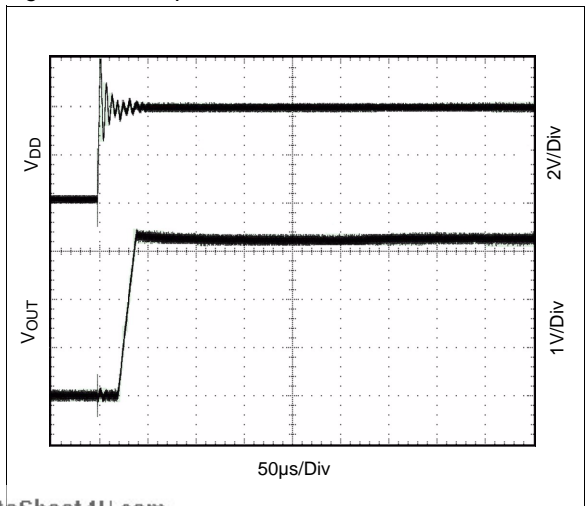

Figure 8. Startup; RLOAD = 11Ω, no CREF

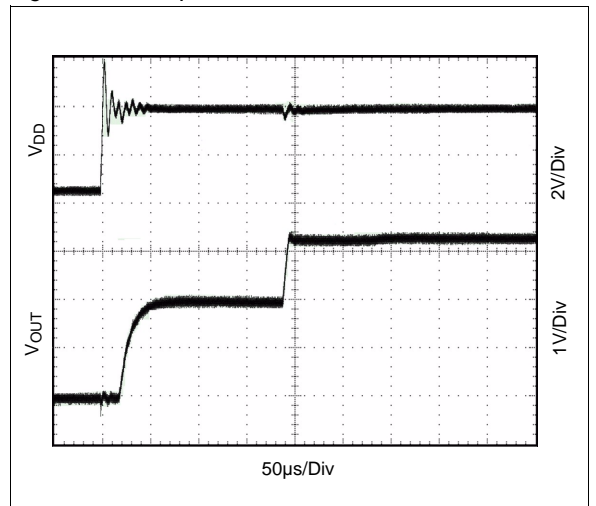

Figure 9. Startup; no Load, $C_{REF} = 100nF$

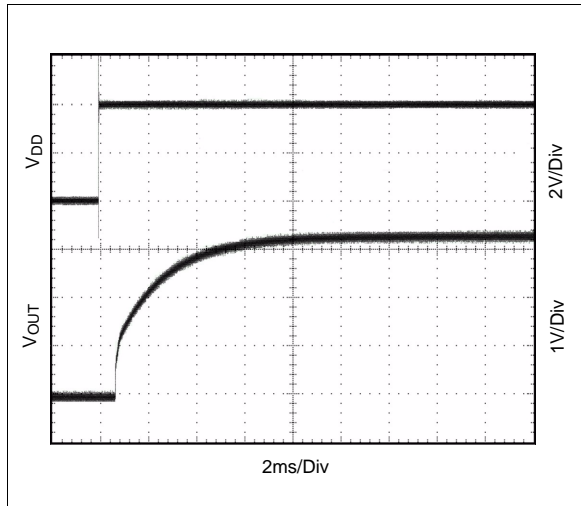

Figure 10. Startup; $R_{LOAD} = 11\Omega$, $C_{REF} = 100nF$

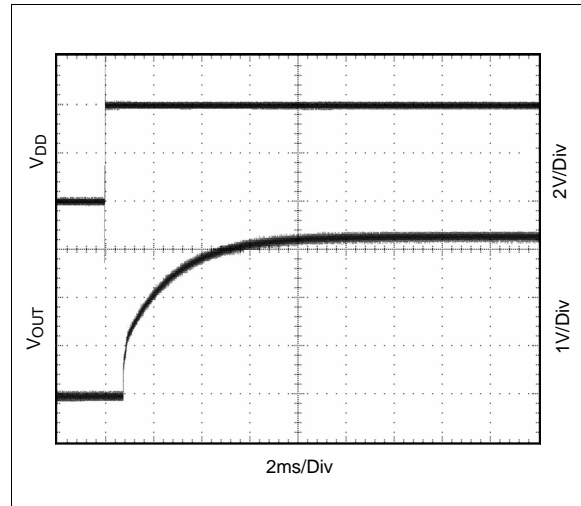

Figure 11. Startup; no Load, $C_{REF} = 100nF$ (pre-charged)

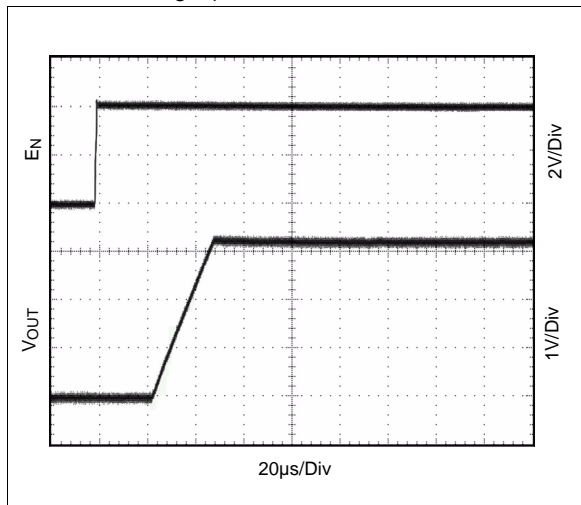

Figure 12. Startup; $R_{LOAD} = 11\Omega$, $C_{REF} = 100nF$ (pre-charged)

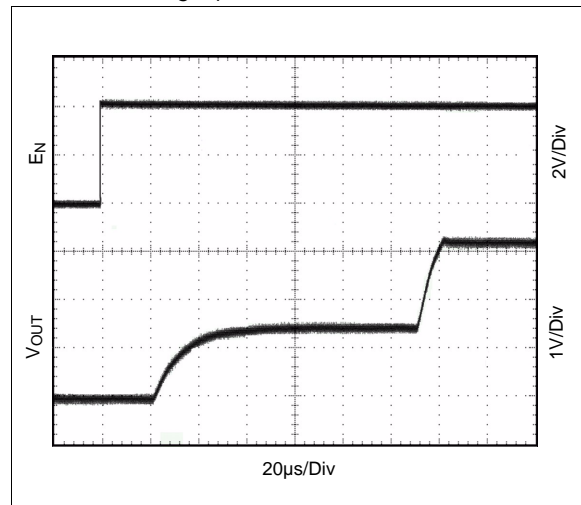

Figure 13. Load Transient Response; $I_{OUT} = 0$ to $300mA$

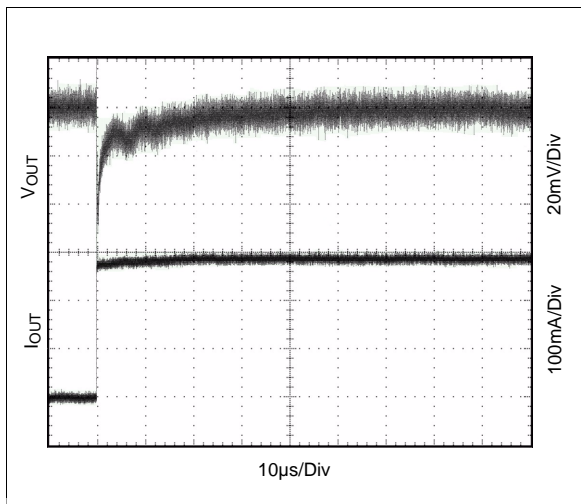
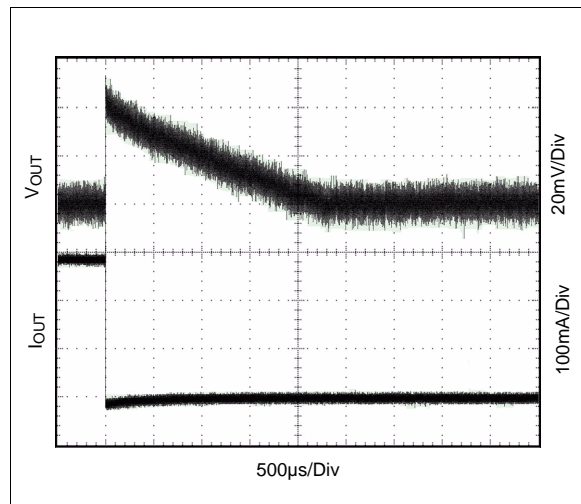
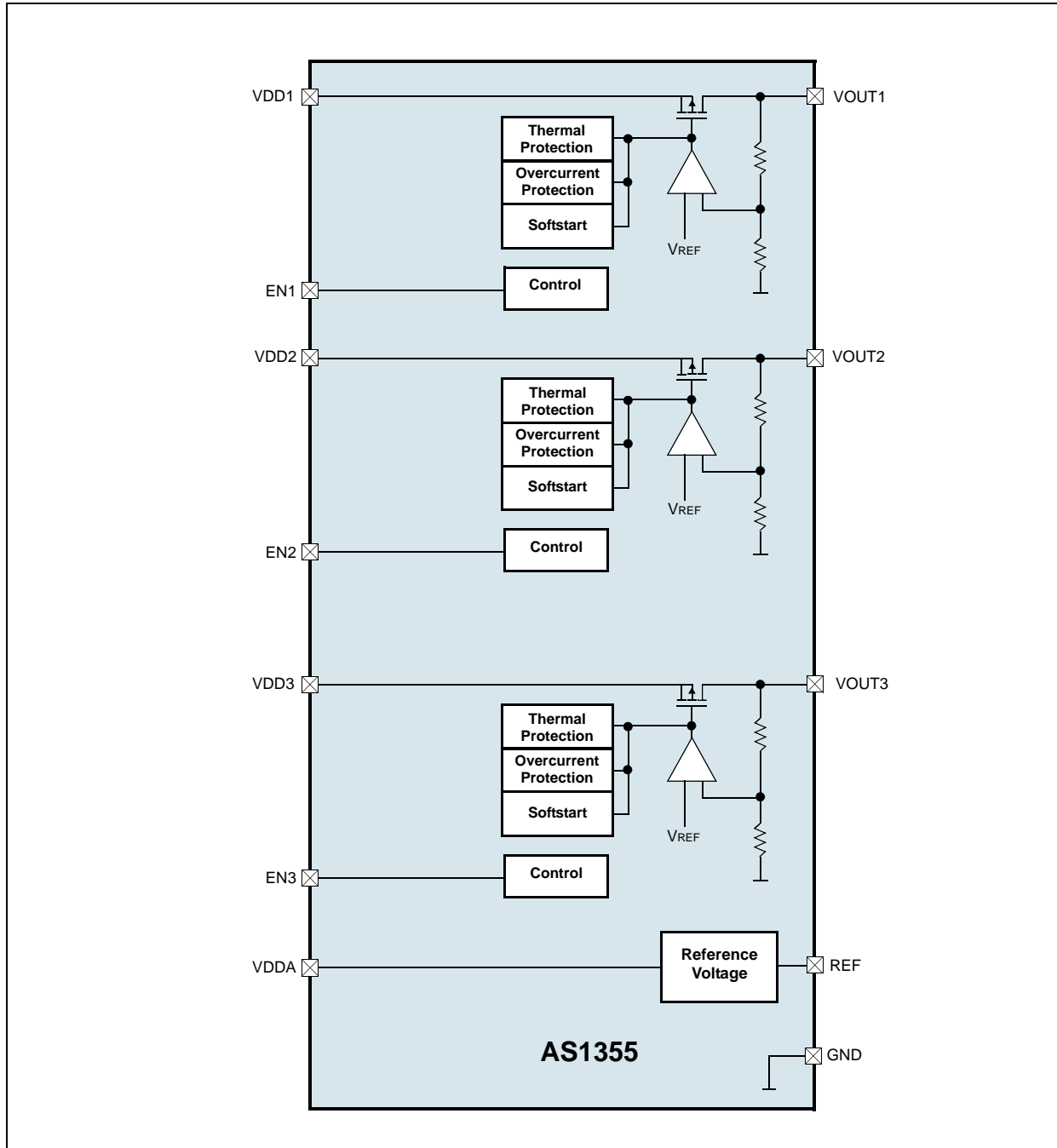

Figure 14. Load Transient Response; $I_{OUT} = 300$ to $0mA$



8 Detailed Description

Figure 15. AS1355 - Block Diagram



9 Typical Application

Figure 16. Typical Application

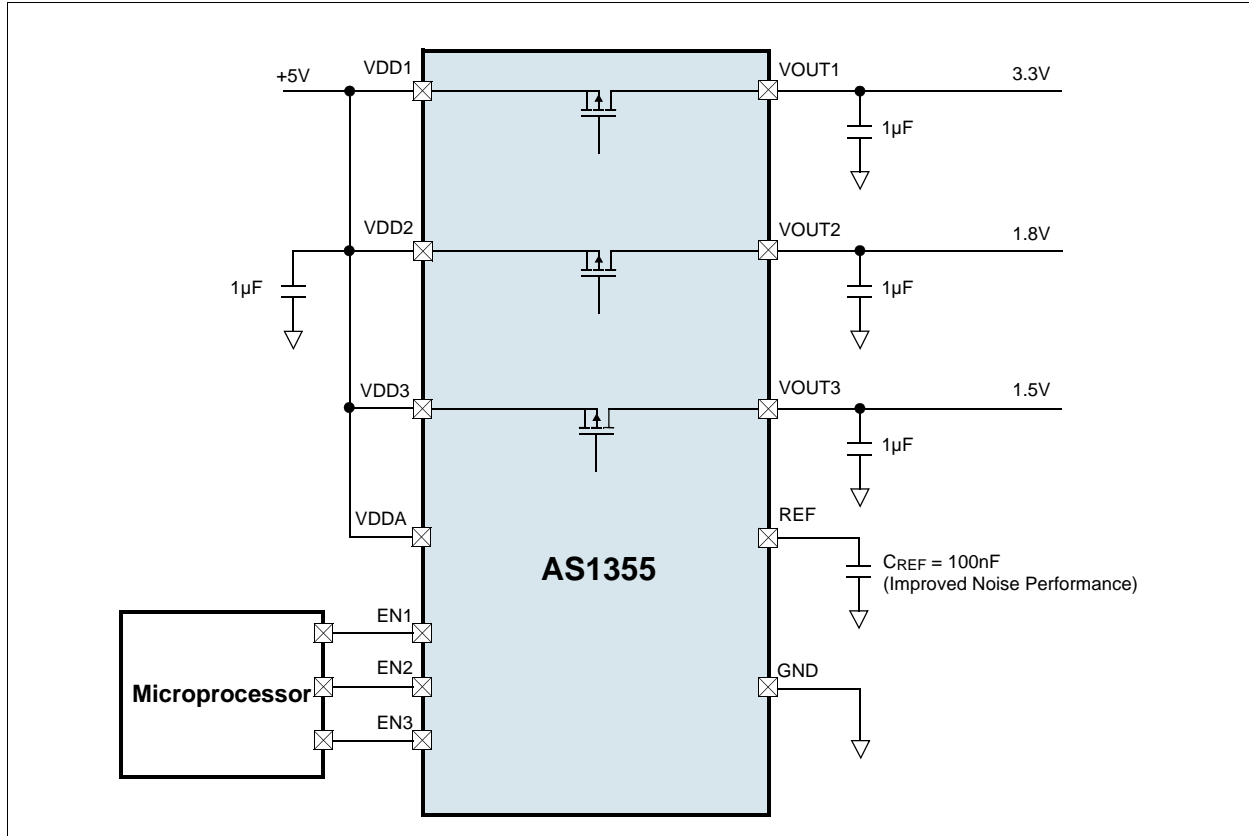

10 Package Drawings and Markings

The AS1355 is available in a 16-pin QFN 3x3 package.

Figure 17. 16-pin QFN 3x3 Package

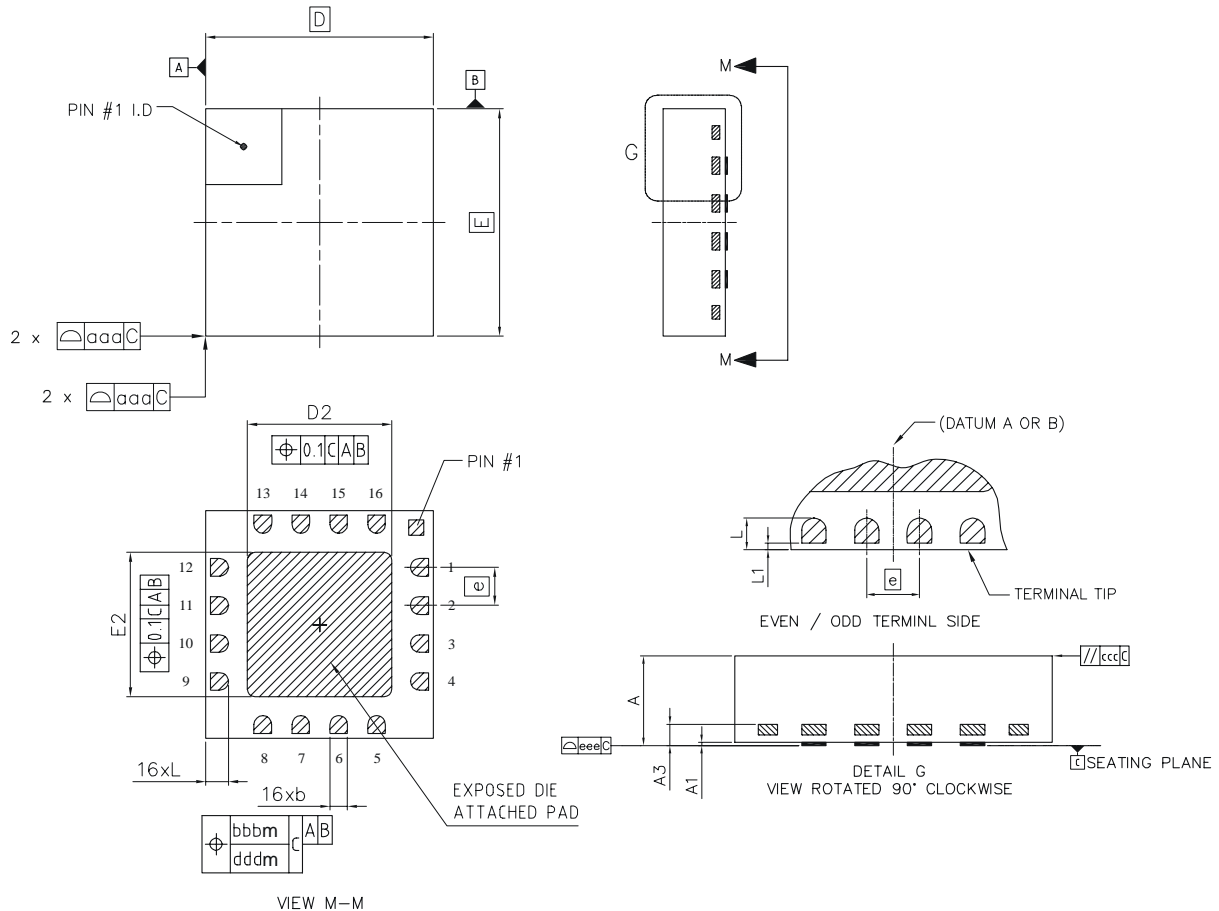

Symbol	Min	Typ	Max
A	0.80	0.85	0.90
A1	0.00		0.05
A3		0.203 REF	
b	0.18	0.23	0.28
D		3.00 BSC	
E		3.00 BSC	
D2	1.80	1.90	2.00
E2	1.80	1.90	2.00

Symbol	Min	Typ	Max
e		0.50 BSC	
L	0.25	0.30	0.35
L1	0.00		0.10
aaa		0.10	
bbb		0.10	
ccc		0.10	
ddd		0.05	
eee		0.08	

Notes:

1. Dimensioning and tolerancing conform to ASME Y14.5m-1994.
2. All dimensions are in millimeters while angle is in degrees (°).
3. Dimension b applies to metallized terminal and is measured between 0.25mm and 0.30mm from the terminal tip. Dimension L1 represents terminal full back from package edge up to 0.1mm is acceptable.
4. Coplanarity applies to the exposed heat slug as well as the terminal.
5. Radius on terminal is optional.

11 Ordering Information

The devices are available as the standard products shown in [Table 4](#).

Table 4. Ordering Information

Ordering Code	Marking	Output	Description	Delivery Form	Package
AS1355-BQFT-WGD	ASSG	V _{OUT1} = 3.3V	300mA, Triple LDO	Tape and Reel	16-pin QFN 3x3
		V _{OUT2} = 1.8V			
		V _{OUT3} = 1.5V			

Non-standard devices are available between 1.25V and 3.6V in 50mV steps. For more information and inquiries contact <http://www.austriamicrosystems.com/contact>

Note: All products are RoHS compliant and Pb-free.

Buy our products or get free samples online at ICdirect: <http://www.austriamicrosystems.com/ICdirect>

For further information and requests, please contact us <mailto:sales@austriamicrosystems.com> or find your local distributor at <http://www.austriamicrosystems.com/distributor>

Copyrights

Copyright © 1997-2009, austriamicrosystems AG, Tobelbaderstrasse 30, 8141 Unterpremstaetten, Austria-Europe. Trademarks Registered ®. All rights reserved. The material herein may not be reproduced, adapted, merged, translated, stored, or used without the prior written consent of the copyright owner.

All products and companies mentioned are trademarks or registered trademarks of their respective companies.

Disclaimer

Devices sold by austriamicrosystems AG are covered by the warranty and patent indemnification provisions appearing in its Term of Sale. austriamicrosystems AG makes no warranty, express, statutory, implied, or by description regarding the information set forth herein or regarding the freedom of the described devices from patent infringement. austriamicrosystems AG reserves the right to change specifications and prices at any time and without notice. Therefore, prior to designing this product into a system, it is necessary to check with austriamicrosystems AG for current information. This product is intended for use in normal commercial applications. Applications requiring extended temperature range, unusual environmental requirements, or high reliability applications, such as military, medical life-support or life-sustaining equipment are specifically not recommended without additional processing by austriamicrosystems AG for each application. For shipments of less than 100 parts the manufacturing flow might show deviations from the standard production flow, such as test flow or test location.

The information furnished here by austriamicrosystems AG is believed to be correct and accurate. However, austriamicrosystems AG shall not be liable to recipient or any third party for any damages, including but not limited to personal injury, property damage, loss of profits, loss of use, interruption of business or indirect, special, incidental or consequential damages, of any kind, in connection with or arising out of the furnishing, performance or use of the technical data herein. No obligation or liability to recipient or any third party shall arise or flow out of austriamicrosystems AG rendering of technical or other services.



Contact Information

Headquarters

austriamicrosystems AG
Tobelbaderstrasse 30
A-8141 Unterpremstaetten, Austria

Tel: +43 (0) 3136 500 0
Fax: +43 (0) 3136 525 01

For Sales Offices, Distributors and Representatives, please visit:

<http://www.austriamicrosystems.com/contact>