



**3A Low Dropout Voltage Regulator
Adjustable & Fixed Output,
Fast Response**

FEATURES

- Adjustable Output Down To 1.2V
- Fixed Output Voltages 1.5, 2.5, 3.3, 5.0V
- Output Current Of 3A
- Low Dropout Voltage 1.1V Typ.
- Extremely Tight Load And Line Regulation
- Current & Thermal Limiting
- Standard 3-Terminal Low Cost TO-220, TO-263 & TO-252
- Similar To Industry Standard LT1085/LT1585

APPLICATIONS

- Powering VGA & Sound Card
- Power PC™ Supplies
- SMPS Post-Regulator
- High Efficiency “Green” Computer Systems
- High Efficiency Linear Power Supplies
- Portable Instrumentation
- Constant Current Regulators
- Adjustable Power Supplies
- Battery charger

PRODUCT DESCRIPTION

The ALPHA Semiconductor AS2830 are low power 3A adjustable and fixed voltage regulators that are very easy to use. It requires only 2 external resistors to set the output voltage for adjustable version. The AS2830 are designed for low voltage applications that offers lower dropout voltage and faster transient response. This device is an excellent choice for use in powering low voltage microprocessor that require a lower dropout, faster transient response to regulate from +2.5V to 3.8V supplies and as a post regulator for switching supplies applications. The AS2830 features low dropout of a maximum 1.2 volts.

The AS2830 offers over current limit and full protection against reversed input polarity, reversed load insertion, and positive and negative transient voltage. On-Chip trimming adjusts the reference voltage to 1%. The I_Q of this device flows into the load, which increases efficiency.

The AS2830 are offered in a 3-pin TO-220, TO-263 & TO-252 packages compatible with other 3 terminal regulators. For a 5A low dropout regulator refer to the AS2850 data sheet.

ORDERING INFORMATION

TO-220 3-PIN	DD PLASTIC 3-PIN	TO-252 DPAK
AS2830YU-X	AS2830YT-X	AS2830YR-X

X = Output Voltage (i.e. 1.5 for 1.5V, 2.5 for 2.5V etc.)

Y= Output Tolerance, Y= A for 1%

Blank for 2%

Consult factory for other fixed voltages.

PIN CONNECTIONS

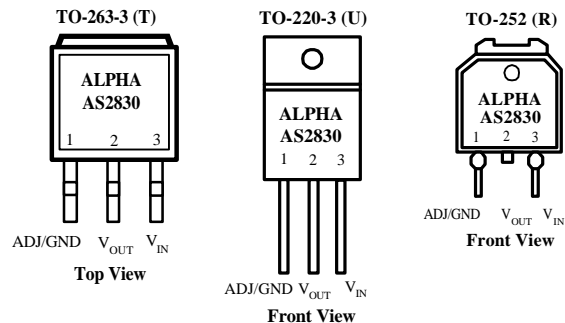

ABSOLUTE MAXIMUM RATINGS

Lead Temp. (Soldering, 10 Seconds) 300°C
 Storage Temperature Range -65° to +150°C
 Operating Junction Temperature Range.....
 AS2830 Control Section..... -45°C +125°C
 AS2830 Power Transistor.....-45°C +150°C

Maximum Input Voltage 10V
 Input to Output Voltage Differential Max..... 8.8V

ELECTRICAL CHARACTERISTICS (NOTE 1) at I_{OUT} = 10mA, T_a = 25°C, unless otherwise specified.

PARAMETER	CONDITIONS	Typ	AS2830A		AS2830		Units
			Min	Max	Min	Max	
1.5V Version							
Output Voltage (Note 2)	AS2830-1.5V, 0 ≤ I _{OUT} ≤ 3A, 2.75V ≤ V _{IN} ≤ 10V	1.5	1.485	1.515	1.470	1.530	V
		1.5	1.470	1.530	1.455	1.545	
2.5V Version							
Output Voltage (Note 2)	AS2830-2.5V, 0 ≤ I _{OUT} ≤ 3A, 4.0V ≤ V _{IN} ≤ 10V	2.5	2.475	2.525	2.450	2.550	V
		2.5	2.450	2.550	2.425	2.575	
3.3V Version							
Output Voltage (Note 2)	AS2830-3.3V, 0 ≤ I _{OUT} ≤ 3A, 4.75V ≤ V _{IN} ≤ 10V	3.3	3.270	3.330	3.230	3.370	V
		3.3	3.240	3.360	3.201	3.399	
5.0V Version							
Output Voltage (Note 2)	AS2830-5.0V, 0 ≤ I _{OUT} ≤ 3A, 6.5V ≤ V _{IN} ≤ 10V	5.0	4.95	5.05	4.900	5.100	V
		5.0	4.90	5.10	4.850	5.150	
All Voltage Options							
Reference Voltage (V _{REF})	V _{IN} ≤ 7V, P ≤ P _{MAX} 1.5V ≤ (V _{IN} - V _{OUT}) ≤ (V _{IN} - V _{OUT}) _{MAX} , 10mA ≤ I _{OUT} ≤ 3A	1.250	1.238	1.263	1.225	1.270	V
			1.225	1.270	1.212	1.288	
Min. Load Current (Note 3)	1.5V ≤ (V _{IN} - V _{OUT}) ≤ (V _{IN} - V _{OUT}) _{MAX}	5		10		10	mA
Line Regulation (ΔV _{REF} (V _{IN}))	2.75V ≤ V _{IN} ≤ 7V, I _{OUT} = 10mA, T _J = 25°C (Note 3)	0.005		0.2		0.2	%
	V _{IN} ≤ 7V, I _{OUT} = 0mA, T _J = 25°C (Note 2)	0.005		0.2		0.2	%
Load Regulation (ΔV _{REF} (I _{OUT}))	10mA ≤ I _{OUT} ≤ 3A, (V _{IN} - V _{OUT}) = 3V, T _J = 25°C (Note 3)	0.05		0.3		0.3	%
	0 ≤ I _{OUT} ≤ 3A, V _{IN} = 7V, T _J = 25°C (Note 2)	0.05		0.3		0.3	%
Dropout Voltage	ΔV _{REF} = 1%	1.1		1.2		1.2	V
	I _{OUT} = 3A I _{OUT} ≤ 3A						
Current Limit I _{OUT(MAX)}	V _{IN} = 7V	4.0	3.2		3.2		A
	1.4V ≤ (V _{IN} - V _{OUT}) (Note 3)						
Long Term Stability	T _A = 125°C, 1000 Hrs.	0.3 (Note 2)		1		1	%
Thermal Regulation (ΔV _{OUT} (Pwr))	T _A = 25°C, 20 ms pulse	0.01		0.020		0.020	%/W
Temperature Stability (ΔV _{OUT} (T))		0.25					%
Output Noise, RMS	10Hz to 10kHz T _A = 25°C	0.003					%V
Thermal Resistance	TO-220	Junction to Tab		3.0		3.0	°C/W
		Junction to Ambient		60		60	
	DD Package	Junction to Tab		3.0		3.0	
		Junction to Ambient		60		60	

The Bold specifications apply to the full operating temperature range.

Note 1: Changes in output voltage due to heating effects are covered under the specification for thermal regulation.

Note 2: Fixed Version Only

Note 3: Adjustable Version Only

APPLICATION HINTS

The ALPHA Semiconductor AS2830 incorporates protection against over-current faults, reversed load insertion, over temperature operation, and positive and negative transient voltage. However, the use of an output capacitor is required in order to improve the stability and the performances.

Stability

The output capacitor is part of the regulator's frequency compensation system. Either a 22 μ F aluminum electrolytic capacitor or a 10 μ F solid tantalum capacitor between the output terminal and ground guarantees stable operation for all operating conditions.

However, in order to minimize overshoot and undershoot, and therefore optimize the design, please refer to the section 'Ripple Rejection'.

Ripple Rejection

Ripple rejection can be improved by adding a capacitor between the ADJ pin and ground as shown in figure 6. When ADJ pin bypassing is used, the value of the output capacitor required increases to its maximum (22 μ F for an aluminum electrolytic capacitor, or 10 μ F for a solid tantalum capacitor). If the ADJ pin is not bypass, the value of the output capacitor can be lowered to 10 μ F for an electrolytic aluminum capacitor or 4.7 μ F for a solid tantalum capacitor. However the value of the ADJ-bypass capacitor should be chosen with respect to the following equation:

$$C = 1 / (6.28 * F_R * R_1)$$

Where C = value of the capacitor in Farads (select an equal or larger standard value),

F_R = ripple frequency in Hz,

R_1 = value of resistor R_1 in Ohms.

If an ADJ-bypass capacitor is use, the amplitude of the output ripple will be independent of the output voltage. If an ADJ-bypass capacitor is not used, the output ripple will be proportional to the ratio of the output voltage to the reference voltage:

$$M = V_{OUT} / V_{REF}$$

Where M = multiplier for the ripple seen when the ADJ pin is optimally bypassed.

V_{REF} = Reference Voltage

Reducing parasitic resistance and inductance

One solution to minimize parasitic resistance and inductance is to connect in parallel capacitors. This arrangement will improve the transient response of the power supply if your system requires rapidly changing current load condition.

Thermal Consideration

Although the AS2830 offers some limiting circuitry for overload conditions, it is necessary not to exceed the maximum junction temperature, and therefore to be careful about thermal resistance. The heat flow will follow the lowest resistance path, which is the Junction-to-case thermal resistance. In order to insure the best thermal flow of the component, a proper mounting is required. Note that the case of the device is electrically connected to the output. In case the case has to be electrically isolated, a thermally conductive spacer can be used. However do not forget to consider its contribution to thermal resistance.

Assuming:

$$V_{IN} = 10V, V_{OUT} = 5V, I_{OUT} = 1.5A, T_A = 50^{\circ}C/W,$$

$$\theta_{Heatsink\ Case} = 6^{\circ}C/W, \theta_{Heatsink\ Case} = 0.5^{\circ}C/W, \theta_{JC} = 3^{\circ}C/W$$

Power dissipation under this condition

$$P_D = (V_{IN} - V_{OUT}) * I_{OUT} = 7.5W$$

Junction Temperature

$$T_J = T_A + P_D * (\theta_{Case - HS} + \theta_{HS} + \theta_{JC})$$

For the Control Sections

$$T_J = 50 + 7.5 * (0.5 + 6 + 3) = 121.25^{\circ}C$$

121.25 $^{\circ}$ C < $T_{J(max)}$ for the Control & Power Sections.

In both case reliable operation is insured by adequate junction temperature.

Basic Adjustable Regulator

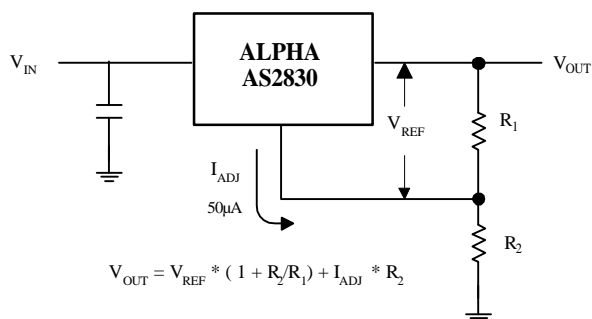

Fig.2 Basic Adjustable Regulator

Output Voltage

Consider Figure 2. The resistance R_1 generates a constant current flow, normally the specified load current of 10mA. This current will go through the resistance R_2 to set the overall output voltage. The current I_{ADJ} is very small and constant. Therefore its contribution to the overall output voltage is very small and can generally be ignored.

Load Regulation

Parasitic line resistance can degrade load regulation. In order not to affect the behavior of the regulator, it is best to connect directly the R_1 resistance from the resistor divider to the case, and not to the load. For the same reason, it is best to connect the resistor R_2 to the Negative side of the load.

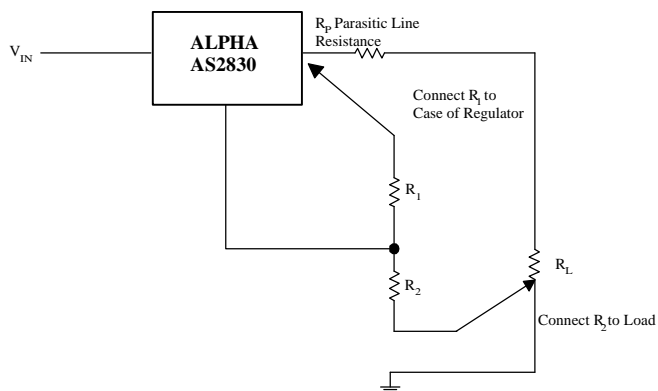
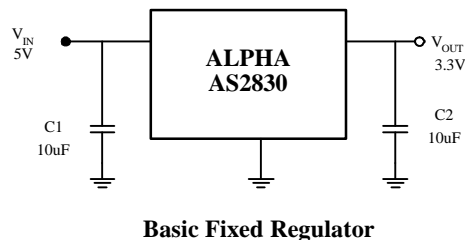

Fig.3 Basic Adjustable Regulator



Basic Fixed Regulator

Output Voltage

The fixed voltage LDO voltage regulators are simple to use regulators since the V_{OUT} is preset to the specifications. It is important however, to provide the proper output capacitance for stability and improvement. For most operating conditions a capacitance of 22µF tantalum or 100µF electrolytic will ensure stability and prevent oscillation.

TYPICAL APPLICATIONS

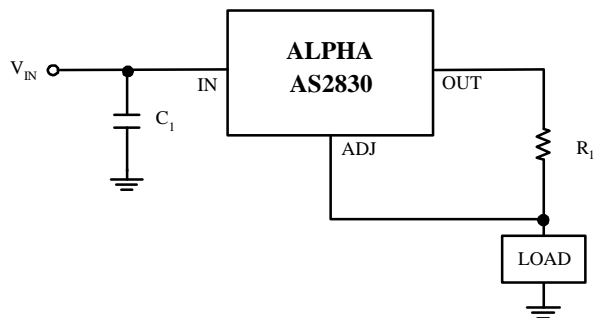

Fig. 4 3A Current output Regulator

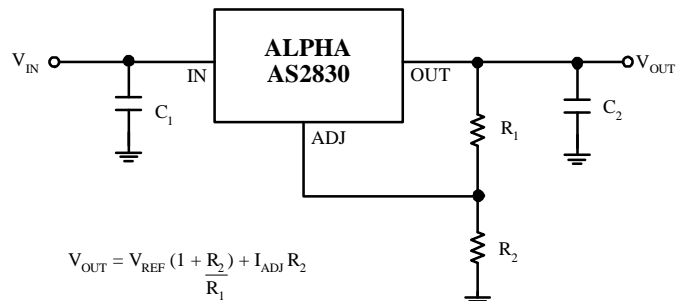

Fig. 5 Typical Adjustable Regulator

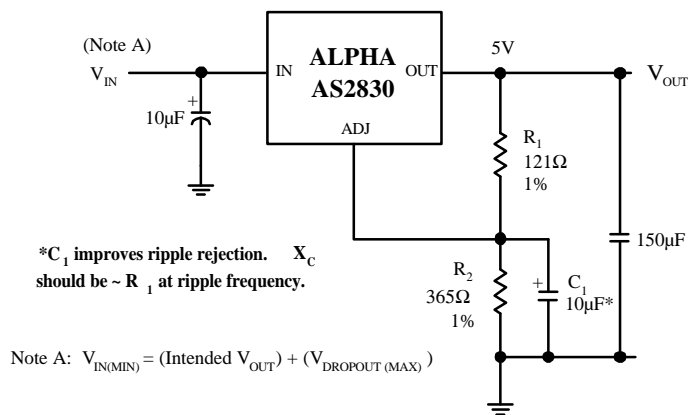

Fig. 6 Improving Ripple Rejection

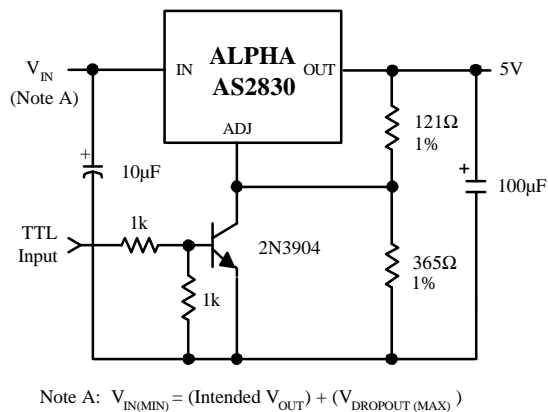
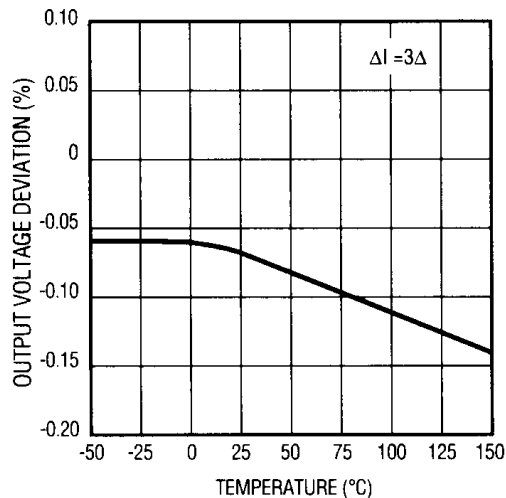

Fig. 7 5V Regulator with Shutdown

TYPICAL CHARACTERISTICS

LOAD REGULATION



SHORT CIRCUIT CURRENT

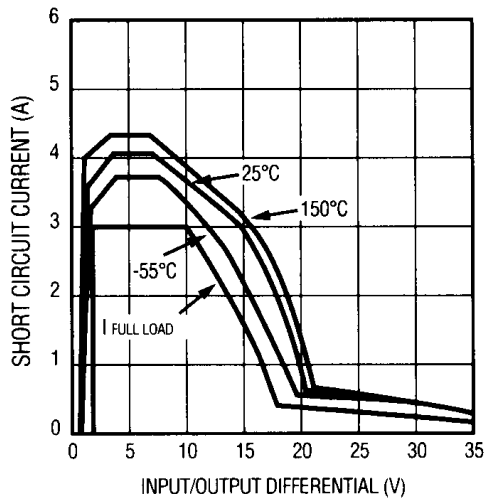

ADJUSTMENT PIN CURRENT

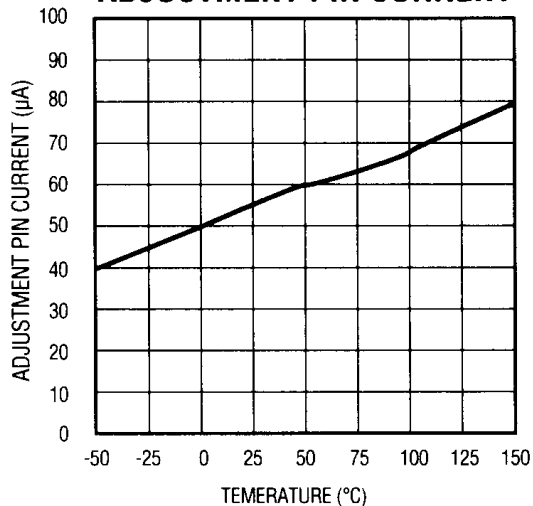

DROPOUT VOLTAGE

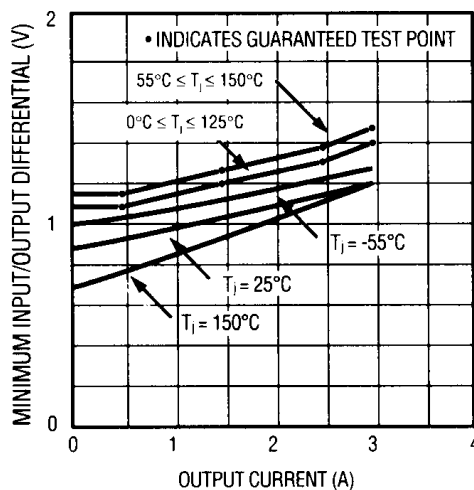

TEMPERATURE STABILITY

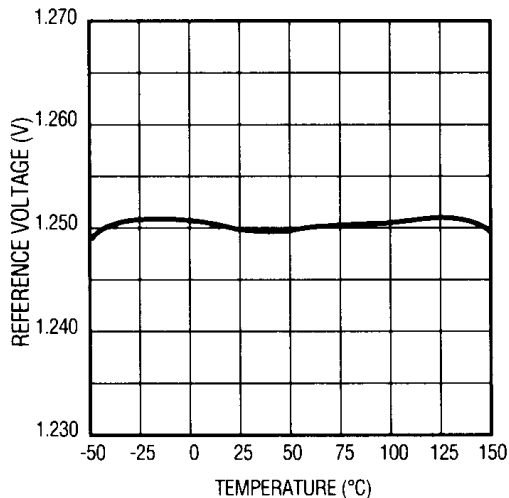

MINIMUM OPERATING CURRENT

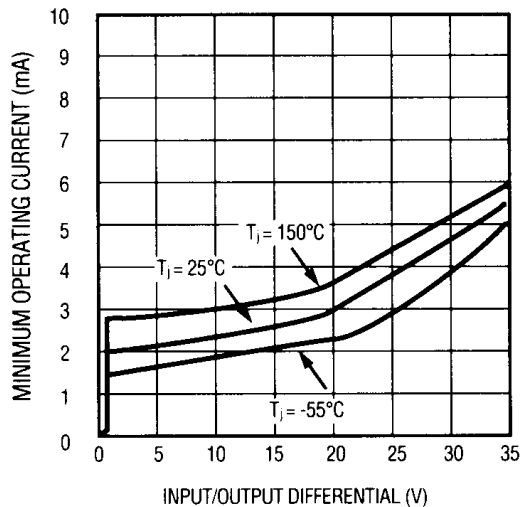

ADVANCE INFORMATION- These data sheets contain descriptions of products that are in development. The specifications are based on the engineering calculations, computer simulation and/ or initial prototype evaluation.

PRELIMINARY INFORMATION- These data sheets contain minimum and maximum specifications that are based on the initial device characterizations. These limits are subject to change upon the completion of the full characterization over the specified temperature and supply voltage ranges.

The information provided here is believed to be reliable and accurate, however ALPHA assumes no responsibility for its use. ALPHA makes no guarantee for any errors that appear in this document. 'Typical' parameters can and do vary in different applications. Customer's technical experts must validate all operating parameters, including 'Typical' for each customer application. Specifications are subject to change without notice, contact ALPHA in order to obtain the latest version of the device specification sheet before using any ALPHA devices. ALPHA is not responsible for any defects that occur in equipment using any ALPHA devices. ALPHA makes no representation that the circuit descriptions herein will not infringe upon existing patent rights.

ALPHA Semiconductor, Inc.
1031 Serpentine Lane
Pleasanton, CA 94566 USA
Tel: (925) 417-1391 Fax: (925) 417-1390
e-mail: alphasem@best.com
web: www.alpha-semi.com

ALPHA Semiconductor-Taiwan
12F, No. 171, Sun Teh Road
Taipei, Taiwan
Tel: 886-2-27281190 Fax: 886-2-27591822
e-mail: alphasemi@ms14.hinet.net

LIFE SUPPORT APPLICATION POLICY: ALPHA Semiconductor products are not authorized for use as critical components in life support devices or systems, nuclear power, aircraft, or space equipment without express written approval from the president of ALPHA Semiconductor.