



**AS2884**

## **8A Low DropOut Voltage Regulator Adjustable & Fixed 3.3V**

### **FEATURES**

- Adjustable Output Down to 1.2V or Fixed 3.3V & 5V
- Output Current of 8A
- Low Dropout Voltage
- Extremely Tight Load and Line Regulation
- Current & Thermal Limiting
- Standard 3-Terminal Low Cost TO-220
- Similar to Industry Standard LT1083/LT1584

### **APPLICATIONS**

- Powering Intel Pentium™  $\mu$ P from +5V Supplies
- Power PC™ Supplies
- SMPS Post-Regulator
- High Efficiency “Green” Computer Systems
- High Efficiency Linear Power Supplies
- Portable Instrumentation
- Constant Current Regulators
- Adjustable Power Supplies
- Battery Charger

### **PRODUCT DESCRIPTION**

The AS2884 is a low power 8A Adjustable Voltage Regulator that is very easy to use. It requires only 2 external resistors to set the output voltage. This device is an excellent choice when using Powering Intel™ Microprocessor to convert from +5V to 3.3V supplies, and as a post regulator for switching supplies applications. The AS2884 features low dropout of a maximum 1.5 volts.

The AS2884 offers full protection against over-current faults, reversed input polarity, reversed load insertion, over temperature operation, and positive and negative transient voltage. On-Chip trimming adjusts the reference voltage to 1%. The  $I_Q$  of this device flows into the load which increases efficiency.

The AS2884 is offered in a 3-pin TO-220 package compatible with older 3-terminal regulators. For a 5A low dropout regulator refer to the AS2850 datasheet.

### **ORDERING INFORMATION**

<b>TO-220</b>
<b>3-PIN</b>
<b>AS2884AU</b>

X = Output Voltage (i.e. 3.3 for 3.3V, 5.0 for 5.0V etc.)

Y = Output Tolerance, A for 1%

Blank for 2%

Consult with factory for fixed output voltage

### **PIN CONNECTIONS**

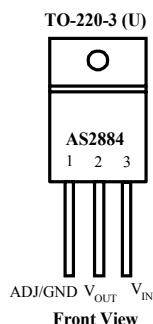

## ABSOLUTE MAXIMUM RATINGS

Power Dissipation.....Internally Limited  
 Lead Temp. (Soldering, 10 Seconds) ..... 300°C  
 Storage Temperature Range ..... -65° to +150°C  
 Operating Junction Temperature Range  
     AS2884 Control Section.....0C° to +125°C  
     AS2884 Power Transistor.....0C° to +150°C

Input Supply Voltage ..... 30V  
 Input to Output Voltage Differential ..... 30V

## ELECTRICAL CHARACTERISTICS (Note 1) at I<sub>OUT</sub> = 10mA, T<sub>A</sub> = 25°C, unless otherwise specified.

Parameter	Conditions	AS2884A			AS2884		Units
		Typ	Min	Max	Min	Max	
<b>3.3V Version</b>							
Output Voltage (Note 2)	AS2884-3.3V, 0 ≤ I <sub>OUT</sub> ≤ 8A, 4.75V ≤ V <sub>IN</sub> ≤ 25V	3.3 <b>3.3</b>	3.270 <b>3.240</b>	3.330 <b>3.360</b>	3.230 <b>3.201</b>	3.370 <b>3.399</b>	V
<b>5.0V Version</b>							
Output Voltage (Note 2)	AS2884-3.3V, 0 ≤ I <sub>OUT</sub> ≤ 8A, 6.5V ≤ V <sub>IN</sub> ≤ 25V	5.0 <b>5.0</b>	4.950 <b>4.900</b>	5.050 <b>5.100</b>	4.900 <b>4.650</b>	5.100 <b>5.150</b>	
<b>All Voltage Options</b>							
Reference Voltage	10 mA ≤ I <sub>OUT</sub> ≤ I <sub>FULLLOAD</sub> 3.3V ≤ (V <sub>IN</sub> - V <sub>OUT</sub> ) ≤ V <sub>IN MAX</sub> - V <sub>OUT MAX</sub>	1.250 <b>1.250</b>	1.238 <b>1.225</b>	1.262 <b>1.270</b>	1.238 <b>1.225</b>	1.262 <b>1.270</b>	V
Mid Load Current	(V <sub>IN</sub> - V <sub>OUT</sub> ) = V <sub>IN MAX</sub> - V <sub>OUT MAX</sub>	<b>5</b>		<b>10</b>		<b>10</b>	mA
Line Regulation	29V ≤ V <sub>IN</sub> - V <sub>OUT</sub> ≤ V <sub>IN MAX</sub> - V <sub>OUT MAX</sub> I <sub>LOAD</sub> = 10mA	0.015 <b>0.05</b>		0.2 <b>0.5</b>		0.2 <b>0.5</b>	%
Load Regulation	10mA ≤ I <sub>OUT</sub> ≤ I <sub>FULLLOAD</sub> (V <sub>IN</sub> - V <sub>OUT</sub> ) = 3V	0.1 <b>0.2</b>		0.3 <b>0.4</b>		0.3 <b>0.4</b>	%
Dropout Voltage	I <sub>OUT</sub> = I <sub>FULLLOAD</sub> , ΔV <sub>REF</sub> = 1%	<b>1.1</b>		<b>1.2</b>		<b>1.2</b>	V
Current Limit	V <sub>IN</sub> - V <sub>OUT</sub> = 5V	<b>9.5</b>	<b>8.0</b>		<b>8.0</b>		A
Long Term Stability	T <sub>A</sub> = 125°C, 1000Hrs.	0.3		1		1	%
Adjust Pin Current	T <sub>A</sub> = 25°C	55		<b>90</b>		<b>90</b>	μA
Adjust Pin Current Change		<b>0.2</b>		<b>5</b>		<b>5</b>	μA
Thermal Regulation	30ms pulse	0.003		0.01		0.01	%/W
Temperature Stability		<b>0.5</b>					%
Ripple Rejection Ratio	V <sub>IN</sub> - V <sub>OUT</sub> = 3V I <sub>OUT</sub> = 3A, C <sub>OUT</sub> = 25μF, C <sub>ADJ</sub> = 25μF, f = 120Hz	<b>75</b>	<b>60</b>		<b>60</b>		dB
Output Noise, RMS	10Hz to 10kHz	0.003					% V <sub>O</sub>
Thermal Resistance Junction-to-Case	TO-220 Junction to Tab Junction to Ambient			2.7 0.65		2.7 0.65	°C/W

The Bold specifications apply to the full operating temperature range.

Note 1: Changes in output voltage due to heating effects are covered under the specification for thermal regulation.

Note 2: A 10μF output capacitor is required on AS2884

## TYPICAL CHARACTERISTICS

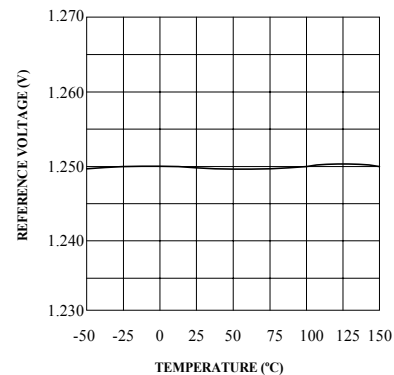
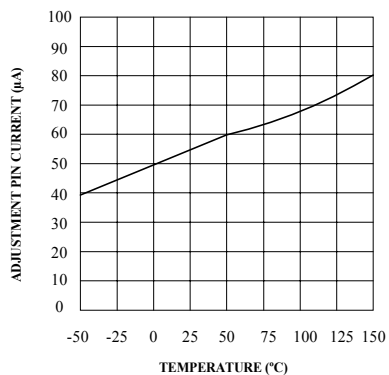
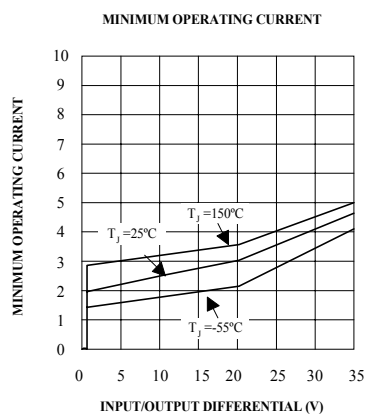
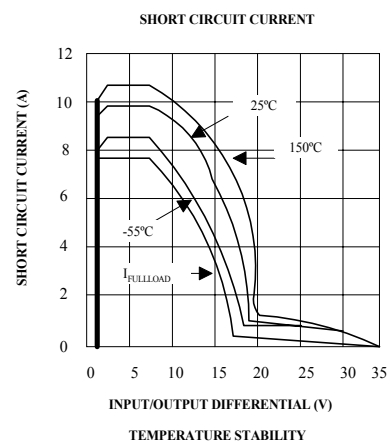
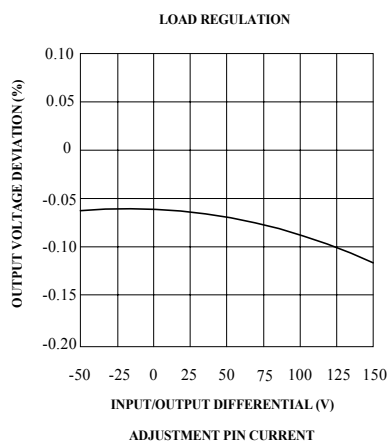
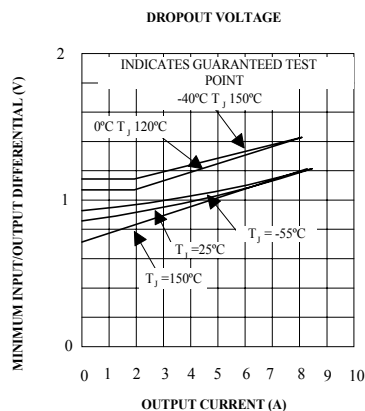

## TYPICAL APPLICATIONS

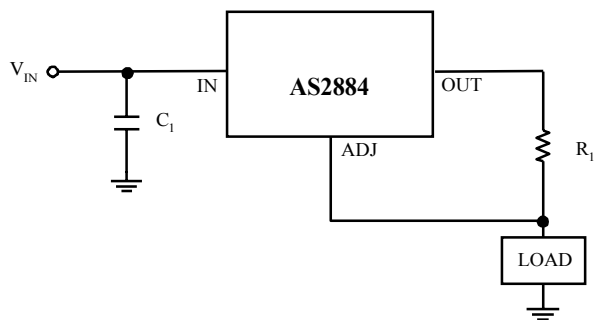

Fig. 4 8A Current output Regulator

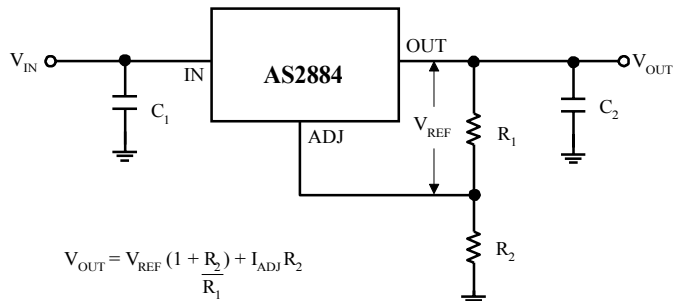
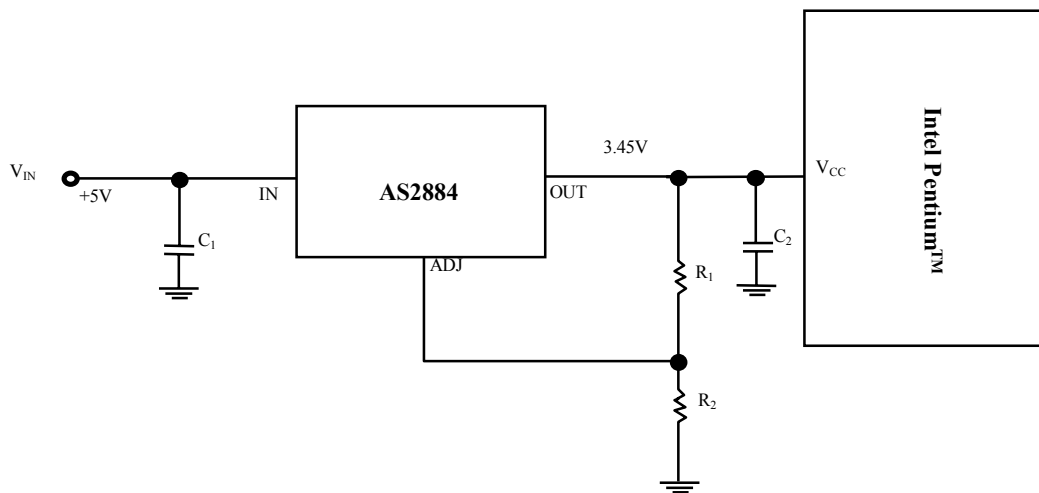

Fig. 5 Typical Adjustable Regulator



Powering Intel Pentium™ with AS2884

Pentium Processor is a trademark of Intel Corp. Power PC is a trademark of IBM Corp.