

LOW-DROPOUT VOLTAGE REGULATOR

AVAILABLE AS MILITARY SPECIFICATIONS

- MIL-STD-883, Class B para 1.2.2 compliant

FEATURES

- High output voltage accuracy
- Guaranteed 750mA output
- Low quiescent current
- Low dropout voltage
- Extremely tight load and line regulation
- Very low temperature coefficient
- Current and thermal limiting
- Input can withstand -20V reverse battery and +60V positive transients
- Logic-controlled electronic shutdown
- Output programmable from 1.24V to 26V
- Available in a 7-lead flatpack package

APPLICATIONS

- Battery powered equipment
- Cellular telephones
- Laptop, notebook, and palmtop computers
- PCMCIA V_{CC} and V_{PP} Regulation/Switching
- Bar code scanners
- Automotive electronics
- SMPS post-regulator/DC to DC modules
- High efficiency linear power supplies

OPTIONS

- Package
7-Lead Flatpack

MARKING

F

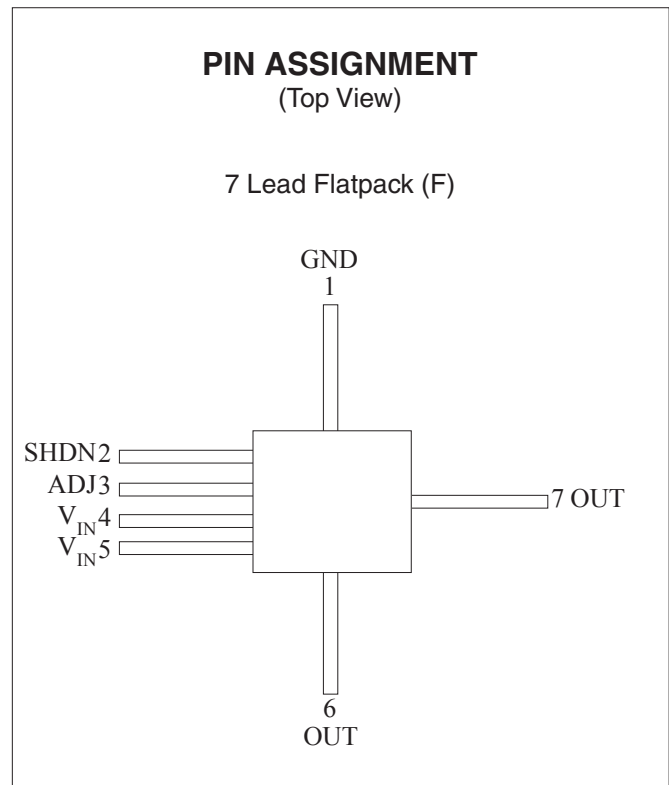

GENERAL DESCRIPTION

The AS29372 is an efficient voltage regulator with very low dropout voltage and very low quiescent current. Key features include protection against reversed battery, fold-back current limiting, and automotive “load dump” protection. A logic compatible input is provided, which allows the device to be switched on and off.

For more products and information
please visit our web site at
www.micross.com

ABSOLUTE MAXIMUM RATINGS¹

Power Dissipation.....	Internally Limited
Lead Temperature (Soldering, 5 seconds).....	260°C
Storage Temperature Range.....	-65°C to +150°C
Operating Junction Temperature Range.....	-40°C to +125°C
	$\theta_{JC} = 14^{\circ}\text{C/W}$
Input Supply Voltage.....	-20V to +60V
Operating Input Supply Voltage*.....	2V to 26V
Adjust Input Voltage ^{9,10}	-1.5V to +26V
Shutdown Input Voltage.....	-0.3V to +30V
Error Comparator Output Voltage.....	-0.3V to +30V

*Across the full operating temperature, the minimum input voltage range for full output current is 4.3V to 26V. Output will remain in-regulation at lower output voltages and low current loads down to an input of 2V at 25°C.

ELECTRICAL CHARACTERISTICS

Limits in standard typeface are for $T_j = 25^{\circ}\text{C}$ and limits in boldface apply over the full operating temperature range, -40°C to $+125^{\circ}\text{C}$. Unless otherwise specified, $V_{IN} = V_{OUT} + 1\text{V}$, $I_L = 5\text{mA}$, $C_L = 10\mu\text{F}$. The AS29372 are programmed for a 5V output voltage, and $V_{SHUTDOWN} \leq 0.6\text{V}$.

SYMBOL	PARAMETER	CONDITIONS	MIN	TYP	MAX	UNITS
$\Delta V_O/\Delta T$	Output Voltage Temperature Coef.	(note 2)		20	100	ppm/°C
$\Delta V_O/\Delta V_{IN}$	Line Regulation	$V_{IN} = V_{OUT} + 1\text{V}$ to 26V $I_L = 2\text{mA}$		0.03	0.10 0.40	%
$\Delta V_O/\Delta I_L$	Load Regulation	$I_L = 5$ to 700 mA (note 3 & 4)		0.04	0.16 0.20	%
$V_{IN} - V_O$	Dropout Voltage (note 5)	$I_L = 5\text{mA}$		80	150 180	mV
		$I_L = 100\text{mA}$		200	250 320	
		$I_L = 500\text{mA}$		300	450 600	
I_{GND}	Ground Pin Current (note 6)	$I_L = 5\text{mA}$, $V_O = 5 \pm 0.1\text{V}$		160	250 300	μA
		$I_L = 100\text{mA}$, $V_O = 5 \pm 0.1\text{V}$		1	2.5 3	mA
		$I_L = 500\text{mA}$, $V_O = 5 \pm 0.1\text{V}$		8	13 16	
$\Delta V_O/\Delta P_D$	Thermal Regulation	(note 9)		0.05	0.2	%/W
	Reference Voltage	(note 7)	1.204		1.26	V
	Adjust Pin Bias Current			20	40 60	nA

ELECTRICAL CHARACTERISTICS (Cont.)

Shutdown Input

PARAMETER	CONDITIONS	MIN	TYP	MAX	UNITS
Input Logic Voltage	Low (ON)			0.7	V
	High (OFF)	2.0			
Shutdown Pin Input Current	VSHUTDOWN = 2.4V		30	50 100	μA
	VSHUTDOWN = 26V		450	600 750	
Regulator Output Current in Shutdown	(note 8)		3	10 20	μA

NOTES:

- Unless otherwise specified, $V_{IN} = V_{OUT} = 1V$, $I_L = 5mA$, $C_L = 10\mu F$, $T_J = T_A$. Device shall be biased in accordance with Figure 1 with $V_{SHUTDOWN} < 0.6V$, $V_{IN} = 6V$, $R_L = 300$ kilohms $\pm 1\%$.
- Output voltage temperature coefficient is defined as the worst case voltage change divided by the total temperature range.
- Regulation is measured at constant junction temperature using low duty cycle pulse testing. Changes in output voltage due to heating effects are covered by the thermal regulation specification.
- This parameter is tested up to 600mA; however, limits are guaranteed but not tested to 750mA.
- Dropout voltage is defined as the input-to-output differential at which the output voltage drops 100mV below its nominal value measured at 1V differential. At very low values of programmed output voltage, the minimum input supply voltage of 2V (2.3V over temperature) must be taken into account.
- Ground pin current is the regulator quiescent current. The total current drawn from the source is the sum of the load current plus the ground pin current.
- $V_{REF} \leq V_{OUT} \leq (V_{IN} - 1V)$, $4.3V \leq V_{IN} \leq 26V$, $5mA \leq I_L \leq 600mA$, $T_J \leq T_{JMAX}$.
- See Figure 1 with $R_L \geq 150$ kilohms, $V_{SHUTDOWN} \geq 2V$, $V_{IN} \leq 26V$, $V_{OUT} = 0$.
- Thermal regulation is defined as the change in output voltage at a time (t) after a change in power dissipation is applied, excluding line and load regulation effects. Specification is for a 200mA load pulse at $V_{IN} = 20V$ (at 4W pulse) for $t = 10ms$.

SCHEMATIC DIAGRAM

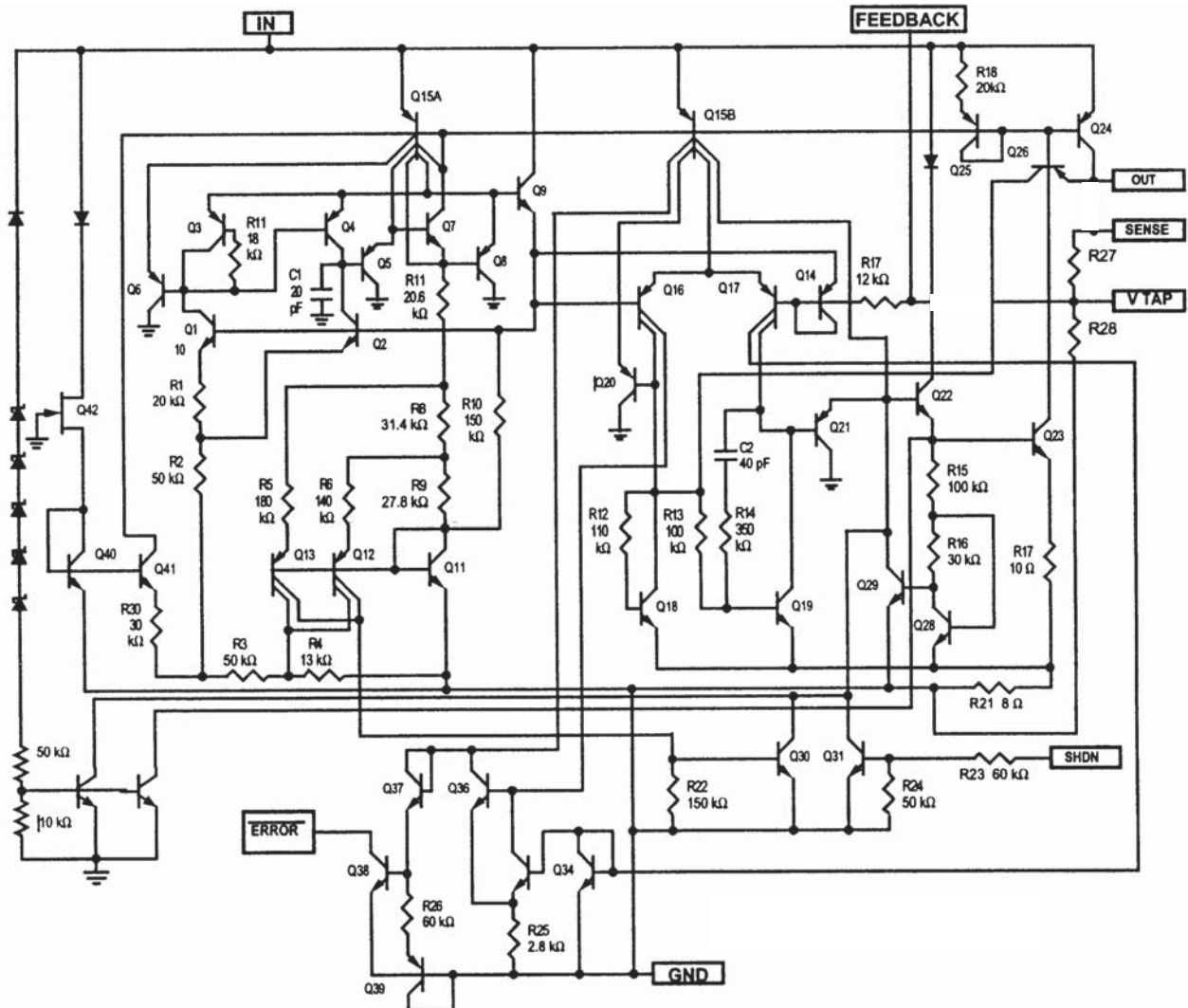



TYPICAL CHARACTERISTICS

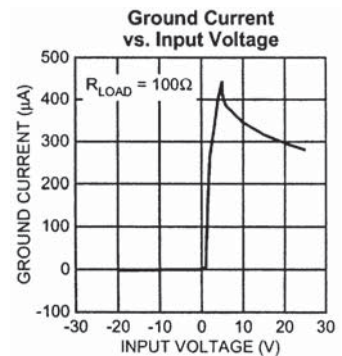
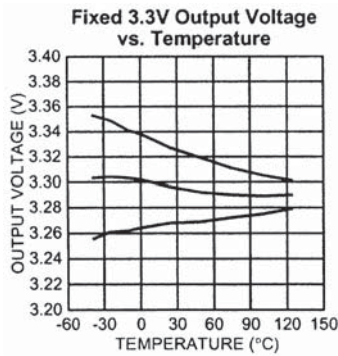
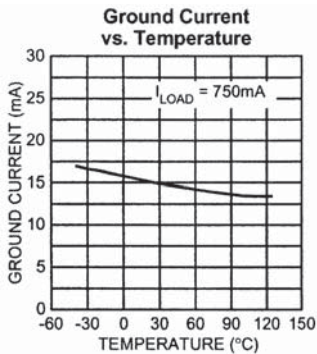
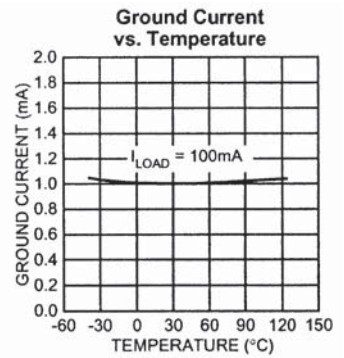
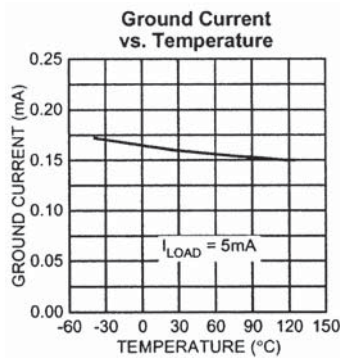
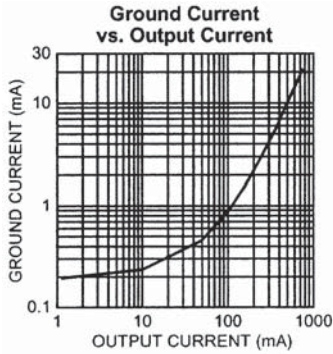
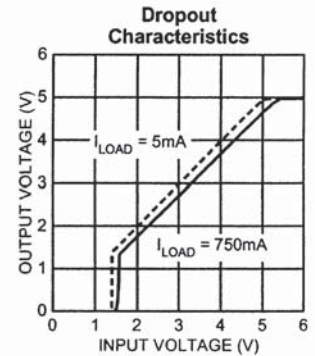
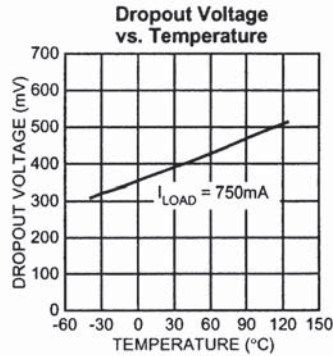
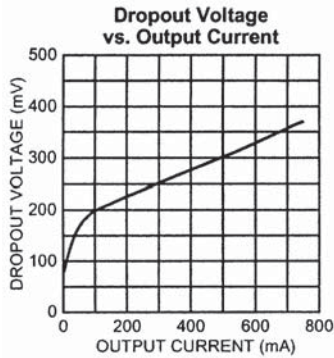



TYPICAL CHARACTERISTICS (Cont.)

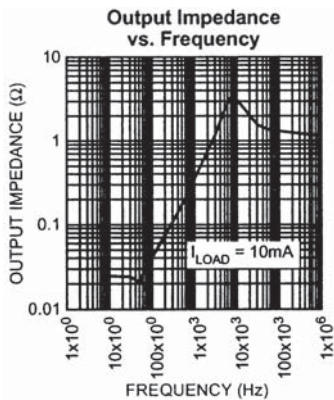
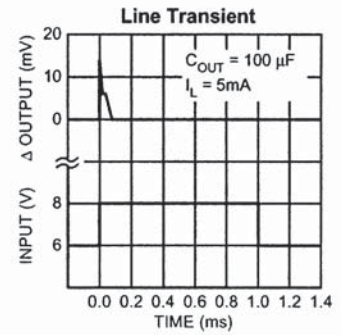
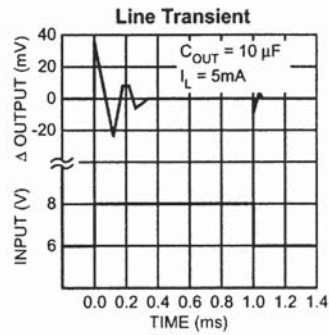
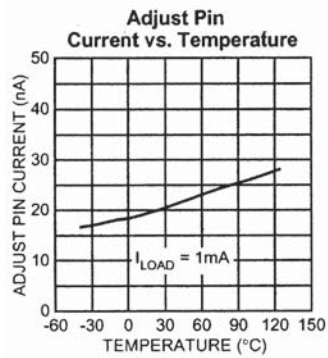
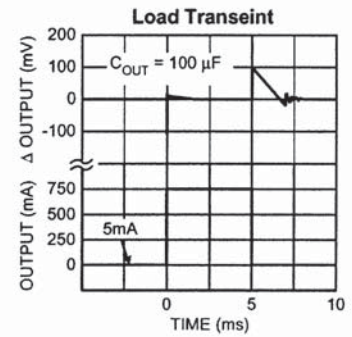
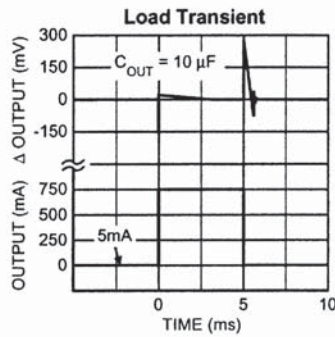
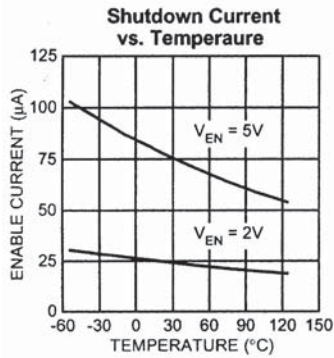

APPLICATIONS INFORMATION

External Capacitors

A 10 μ F (or greater) capacitor is required between the output and ground to prevent oscillations due to instability. Most types of tantalum or aluminum electrolytics will be adequate; film types will work, but are costly and therefore not recommended. Many aluminum electrolytics have electrolytes that freeze at about -30°C, so solid tantalums are recommended for operation below -25°C. The important parameters of the capacitor are an effective series resistance of about 5 Ω or less and a resonant frequency above 500kHz. The value of this capacitor may be increased without limit.

At lower values of output current, less output capacitance is required for output stability. The capacitor can be reduced to 0.5 μ F for current below 10mA or 0.15 μ F for currents below 1mA. Adjusting the AS29372 to voltages below 5V runs the error amplifier at lower gains so that more output capacitance is needed. For the worst-case situation of 750mA load at 1.23V output (Output shorted to Adjust) a 22 μ F (or greater) capacitor should be used.

Programming the Output Voltage

The AS29372 may be programmed for any output voltage between its 1.235V reference and its 26V maximum rating. An external pair of resistors is required, as show in Figure 1.

The complete equation for the output voltage is

$$V_{OUT} = V_{REF} \times \{1 + R_1/R_2\} - |I_{FB}|R_1$$

where V_{REF} is the nominal 1.235 reference voltage and I_{FB} is the Adjust pin bias current, nominally 20nA. The minimum recommended load current of 1 μ A forces an upper limit of 1.2M Ω on the value R_2 , if the regulator must work with no load (a condition often found in CMOS in standby), I_{FB} will produce a -2% typical error in V_{OUT} which may be eliminated at room temperature by trimming R_1 . For better accuracy, choosing $R_2 = 100k$ reduces this error to 0.17% while increasing the resistor program current to 12 μ A. Since the AS29372 typically draws 100 μ A at no load with SHUTDOWN open-circuited, this is a negligible addition.

Reducing Output Noise

In reference applications it may be advantageous to reduce the AC noise present at the output. One method is to reduce the regulator bandwidth by increasing the size of the output capacitor. This is relatively inefficient, as increasing the capacitor from 1 μ F to 220 μ F only decreases the noise from 430 μ V to 160 μ V_{RMS} for a 100kHz bandwidth at 5V output. Noise can be reduced by a factor of four with the adjustable regulators with a bypass capacitor across R_1 , since it reduces the high frequency gain from 4 to unity. Pick

$$C_{BYPASS} \geq \frac{1}{2\pi R_1 H 200 \text{ Hz}}$$

or about 0.01 μ F. When doing this, the output capacitor must be increased to 10 μ F to maintain stability. These changes reduce the output noise from 430 μ V to 100 μ V_{RMS} for a 100kHz bandwidth at 5V output. With the bypass capacitor added, noise no longer scales with output voltage so that improvements are more dramatic at higher output voltages.

TYPICAL APPLICATIONS

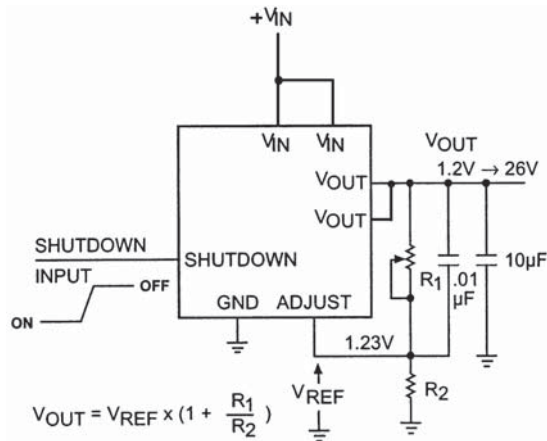
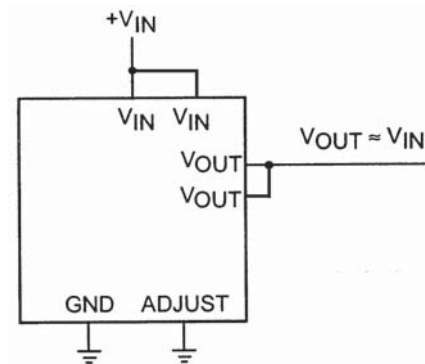
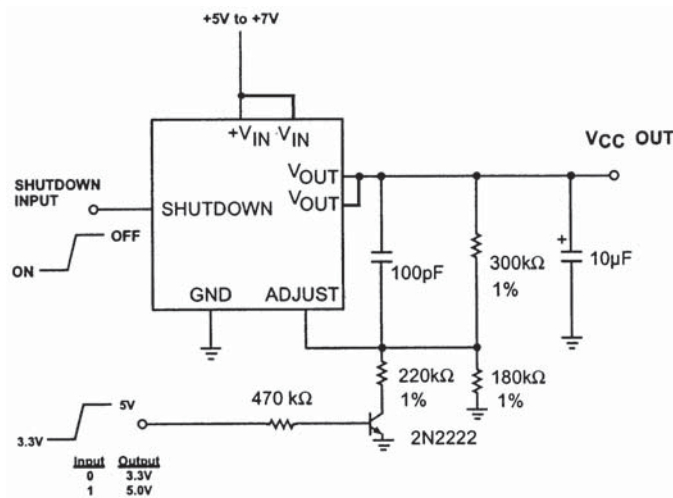

Figure 1. AS29372 Adjustable Regulator



*Minimum INPUT-OUTPUT voltage ranges from 40mV to 400mV, depending on load current.

Figure 2. AS29372 Wide Input Voltage Range Current Limiter



*SHUTDOWN PIN LOW = ENABLE OUTPUT. Q1 ON = 3.3V, Q1 OFF =

Figure 3. AS29372 5.0V or 3.3V Selectable Regulator with Shutdown

MECHANICAL DEFINITIONS*

Package Designator F

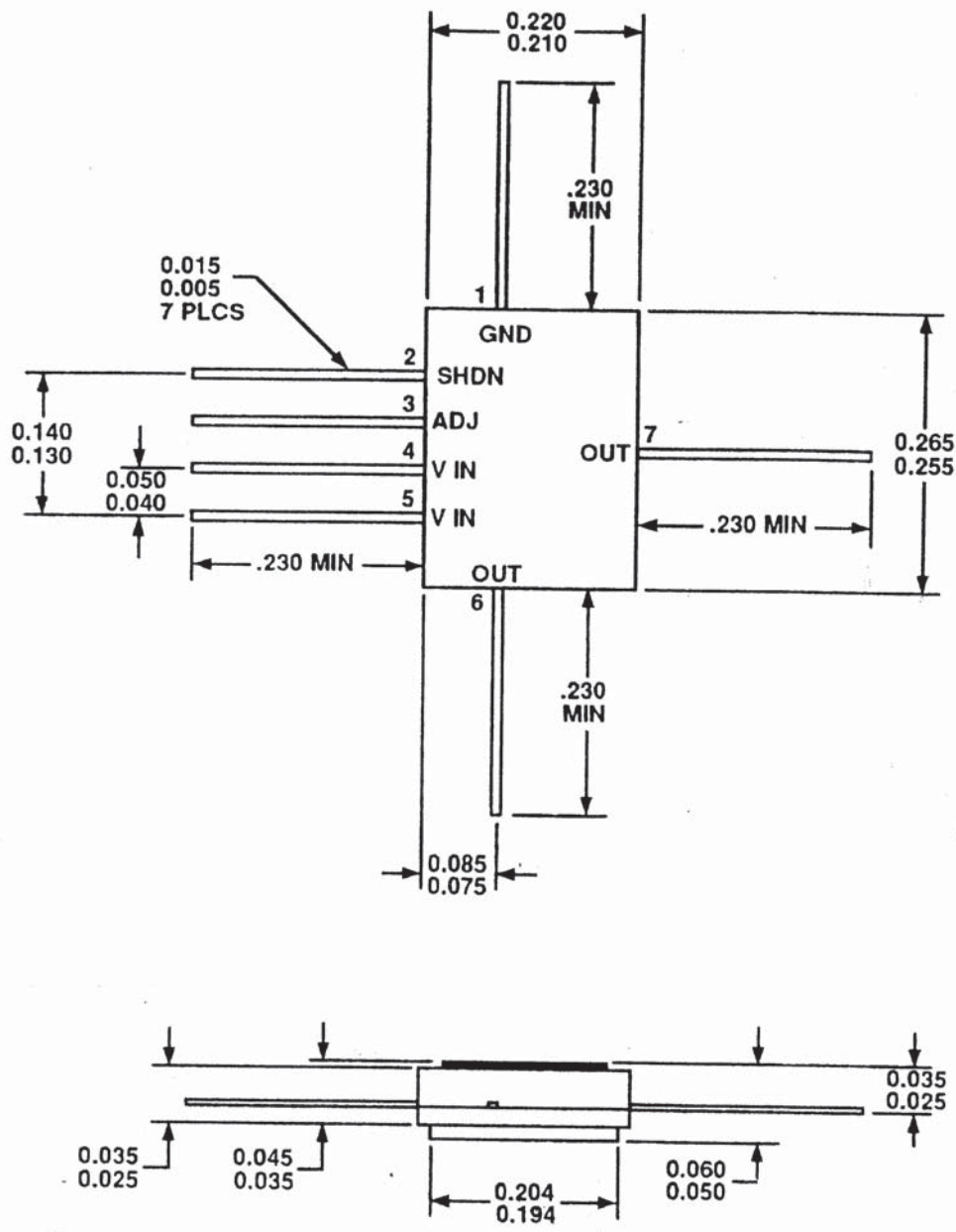

*All measurements are in inches. Drawing is not to scale.

ORDERING INFORMATION

EXAMPLE: AS29372F/883

Device Number	Package Type	Process
AS29372	F	/*

AVAILABLE PROCESSES**AVAILABLE PROCESSES**

IT = Industrial Temperature Range -40°C to +85°C
XT = Extended Temperature Range -55°C to +125°C
MIL = MIL/883 equivalent processing
compliant to paragraph 1.2.2 -55°C to +125°C
SPACE= MIL 883 equivalent SPACE -55°C to +125°C
Process flow compliant to para 1.2.2