

**LOW POWER SINGLE OPERATIONAL AMPLIFIER****AS321****General Description**

The AS321 is a high gain and internally frequency compensated operational amplifier specifically designed to operate from a single power supply. Operation from split power supply is also possible and the low power supply current drain is independent of the magnitude of the power supply voltages. Typical applications include battery charger, active filters, general purpose controllers and most conventional operational amplifier circuits.

The AS321 is compatible with industry standard 321.

The AS321 is available in SOT-23-5L packages.

Features

- Excellent Phase Margin: 60 deg.
- Large Voltage Gain: 100dB (Typical)
- Low Input Bias Current: 20nA (Typical)
- Low Input Offset Voltage: 2mV (Typical)
- Low Supply Current: 0.35mA at $V_{CC}=5V$
- Wide Power Supply Voltage:
Single Supply: 3V to 36V
Dual Supplies: $\pm 1.5V$ to $\pm 18V$
- Wide Input Common Mode Voltage Range: 0V to $V_{CC}-1.5V$

Applications

- Battery Charger
- Active Filters
- General Purpose Controllers, Instruments

www.DataSheet4U.com

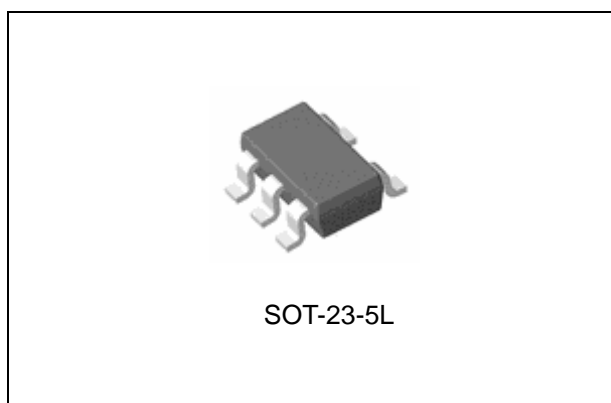

Figure 1. Package Type of AS321



LOW POWER SINGLE OPERATIONAL AMPLIFIER

AS321

Pin Configuration

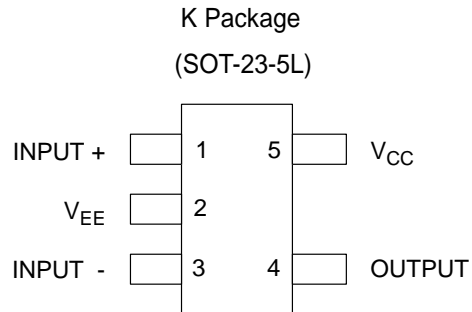

Figure 2. Pin Configuration of AS321 (Top View)

Functional Block Diagram

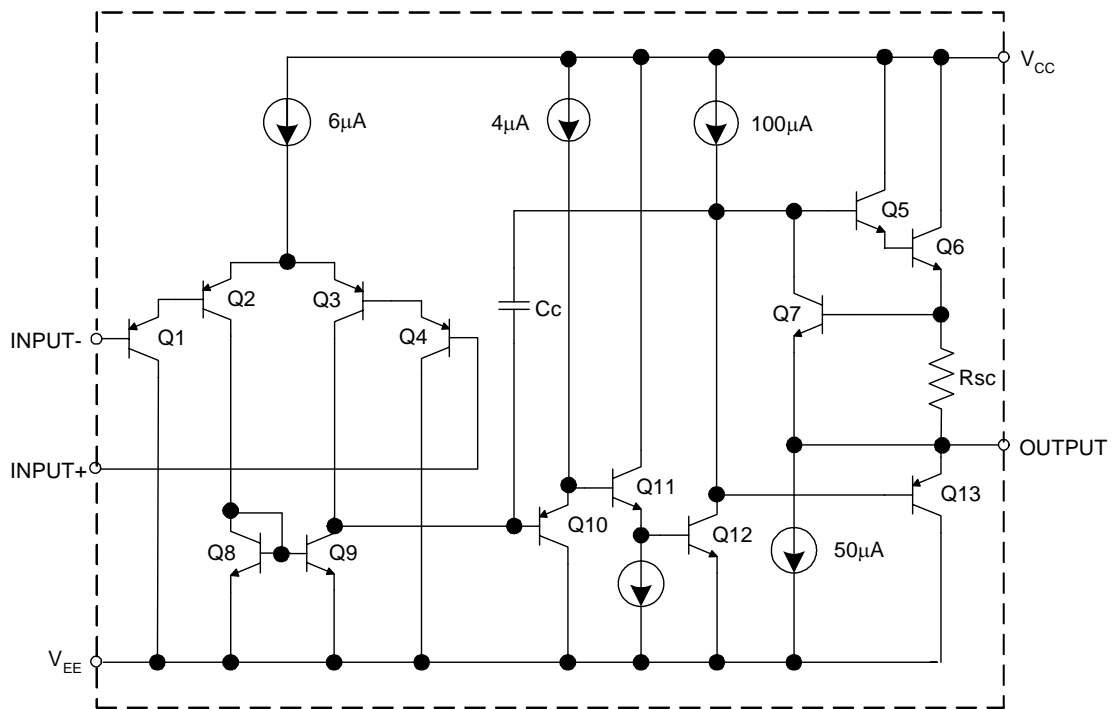
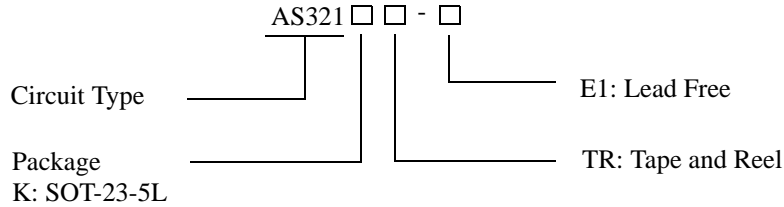

Figure 3. Functional Block Diagram of AS321



LOW POWER SINGLE OPERATIONAL AMPLIFIER AS321

Ordering Information



Package	Temperature Range	Part Number	Marking ID	Packing Type
		Lead Free	Lead Free	
SOT-23-5L	-40 to 85°C	AS321KTR-E1	E6T	Tape & Reel

BCD Semiconductor's Pb-free products, as designated with "E1" suffix in the part number, are RoHS compliant.

Absolute Maximum Ratings (Note 1)

Parameter	Symbol	Value	Unit
Power Supply Voltage	V_S ($V_{CC}-V_{EE}$)	40	V
Differential Input Voltage	V_{ID}	40	V
Input Voltage	V_{IN}	-0.3 to 40	V
Thermal Resistance to Ambient	$R_{\theta JA}$	260	°C/W
Operating Junction Temperature	T_J	150	°C
Storage Temperature Range	T_{STG}	-65 to 150	°C
Lead Temperature (Soldering, 10 Seconds)	T_{LEAD}	260	°C

Note 1: Stresses greater than those listed under "Absolute Maximum Ratings" may cause permanent damage to the device. These are stress ratings only, and functional operation of the device at these or any other conditions beyond those indicated under "Recommended Operating Conditions" is not implied. Exposure to "Absolute Maximum Ratings" for extended periods may affect device reliability.

Recommended Operating Conditions

Parameter	Symbol	Min	Max	Unit
Supply Voltage	V_{CC}	3	36	V
Ambient Operating Temperature Range	T_A	-40	85	°C



LOW POWER SINGLE OPERATIONAL AMPLIFIER

AS321

Electrical Characteristics

Limits in standard typeface are for $T_A=25^{\circ}\text{C}$, **bold** typeface applies over -40°C to 85°C (Note 2), $V_{CC}=5\text{V}$, $V_{EE}=0\text{V}$, $V_O=1.4\text{V}$ unless otherwise specified.

Parameter	Symbol	Conditions	Min	Typ	Max	Unit
Input Offset Voltage	V_{IO}	$V_O=1.4\text{V}$, $R_S=0\Omega$, $V_{CC}=5\text{V}$ to 30V (Note 3)		2	5	mV
					7	
Average Temperature Coefficient of Input Offset Voltage	$\Delta V_{IO}/\Delta T$	$T_A=-40$ to 85°C		7		$\mu\text{V}/^{\circ}\text{C}$
Input Bias Current	I_{BIAS}	I_{IN+} or I_{IN-} , $V_{CM}=0\text{V}$		20	100	nA
					200	
Input Offset Current	I_{IO}	$I_{IN+} - I_{IN-}$, $V_{CM}=0\text{V}$		5	30	nA
					100	
Input Common Mode Voltage Range (Note 4)	V_{CM}	$V_{CC}=30\text{V}$, $\text{CMRR} \geq 50\text{dB}$	0		$V_{CC}-1.5$	V
Supply Current	I_{CC}	$R_L=\infty$, $V_{CC}=5\text{V}$		0.35	0.80	mA
				0.45	1.0	
		$R_L=\infty$, $V_{CC}=30\text{V}$		0.45	1.2	mA
				0.65	1.5	
Large Signal Voltage Gain	G_V	$V_{CC}=15\text{V}$, $V_O=1\text{V}$ to 11V , $R_L \geq 2\text{k}\Omega$	85	100		dB
			80			
Common Mode Rejection Ratio	CMRR	$V_{CM}=0\text{V}$ to $(V_{CC}-1.5)\text{V}$, $R_S \leq 10\text{k}\Omega$	60	70		dB
			60			
Power Supply Rejection Ratio	PSRR	$V_{CC}=5\text{V}$ to 30V , $R_S \leq 10\text{k}\Omega$	70	100		dB
			60			
Output Current	Source	I_{SOURCE}	$V_{IN+}=1\text{V}$, $V_{IN-}=0\text{V}$, $V_{CC}=15\text{V}$, $V_O=2\text{V}$	20	40	mA
				20		
	Sink	I_{SINK}	$V_{IN+}=0\text{V}$, $V_{IN-}=1\text{V}$, $V_{CC}=15\text{V}$, $V_O=2\text{V}$	10	15	mA
				5		
			$V_{IN+}=0\text{V}$, $V_{IN-}=1\text{V}$, $V_{CC}=15\text{V}$, $V_O=0.2\text{V}$	12	50	μA
Output Short Circuit Current to Ground	I_{SC}	$V_{CC}=15\text{V}$		40	60	mA
Output Voltage Swing	V_{OH}	$V_{CC}=30\text{V}$, $R_L=2\text{k}\Omega$	26			V
			26			
		$V_{CC}=30\text{V}$, $R_L=10\text{k}\Omega$	27	28		
			27			
	V_{OL}	$V_{CC}=5\text{V}$, $R_L=10\text{k}\Omega$		5	20	mV
				30		



LOW POWER SINGLE OPERATIONAL AMPLIFIER

AS321

Electrical Characteristics (Continued)

Limits in standard typeface are for $T_A=25^{\circ}\text{C}$, **bold** typeface applies over -40°C to 85°C (Note 2), $V_{CC}=5\text{V}$, $V_{EE}=0\text{V}$, $V_O=1.4\text{V}$ unless otherwise specified.

Parameter	Symbol	Conditions	Min	Typ	Max	Unit
Total Harmonic Distortion	THD	$f=1\text{kHz}$, $A_V=20\text{dB}$, $R_L=2\text{k}\Omega$, $V_O=2\text{V}_{p-p}$, $C_L=100\text{pF}$, $V_{CC}=30\text{V}$		0.015		%
Phase Margin	ϕ_M			60		Deg

Note 2: Limits over the full temperature are guaranteed by design, but not tested in production.

Note 3: Over the full input common-mode range 0V to $V_{CC}-1.5\text{V}$ (at 25°C).

Note 4: The input common-mode voltage of either input signal voltage should not be allowed to go negatively by more than 0.3V (at 25°C). The upper end of the common-mode voltage range is $V_{CC}-1.5\text{V}$ (at 25°C), but either or both inputs can go to $+36\text{V}$ without damages, independent of the magnitude of the V_{CC} .

Typical Performance Characteristics

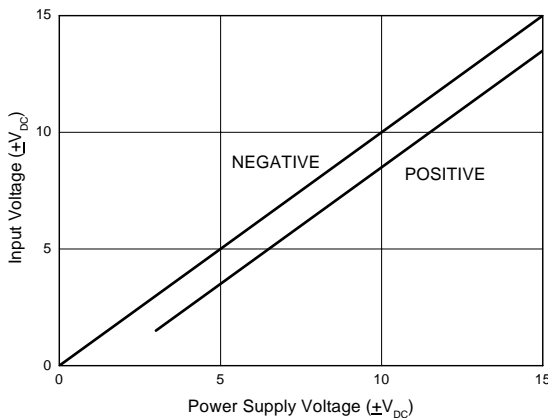

Figure 4. Input Voltage Range

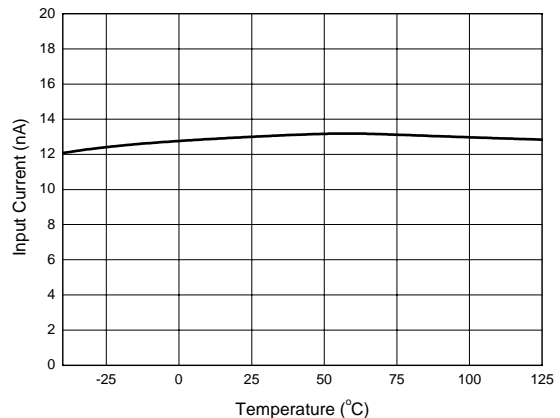

Figure 5. Input Current



LOW POWER SINGLE OPERATIONAL AMPLIFIER

AS321

Electrical Characteristics (Continued)

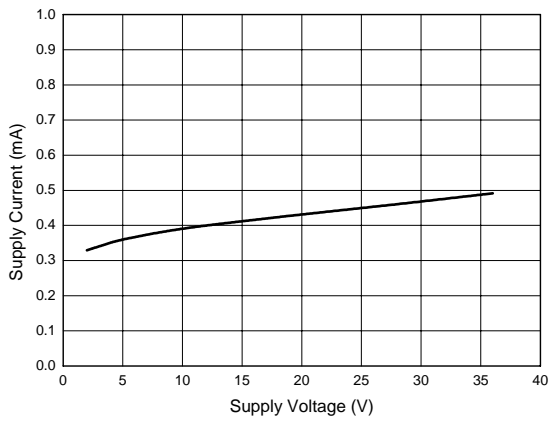

Figure 6. Supply Current

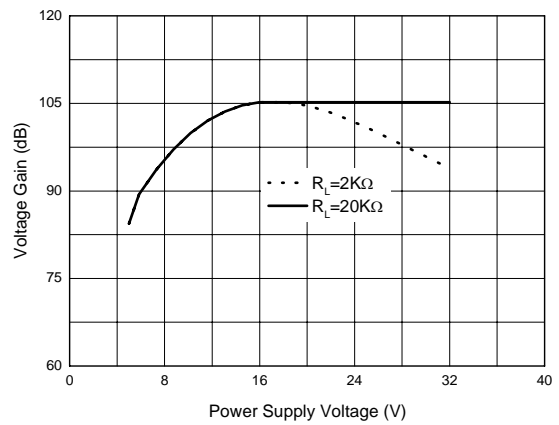

Figure 7. Voltage Gain

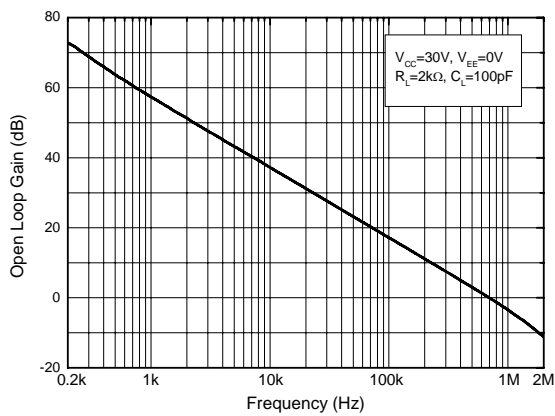

Figure 8. Open Loop Gain vs. Frequency

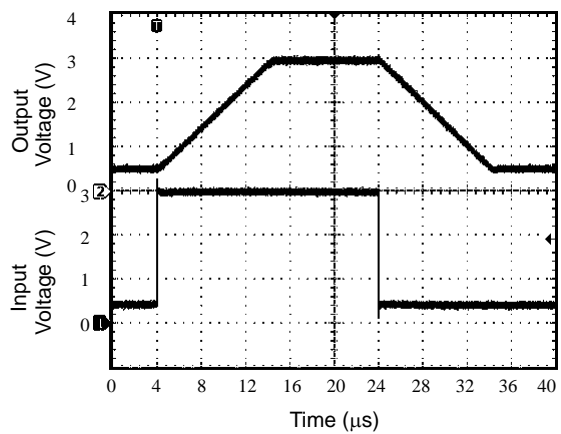

Figure 9. Voltage Follower Pulse Response



LOW POWER SINGLE OPERATIONAL AMPLIFIER

AS321

Typical Performance Characteristics (Continued)

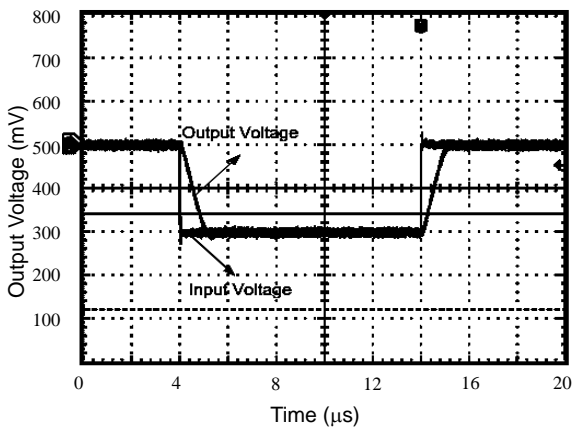

Figure 10. Voltage Follower Pulse Response (Small Signal)

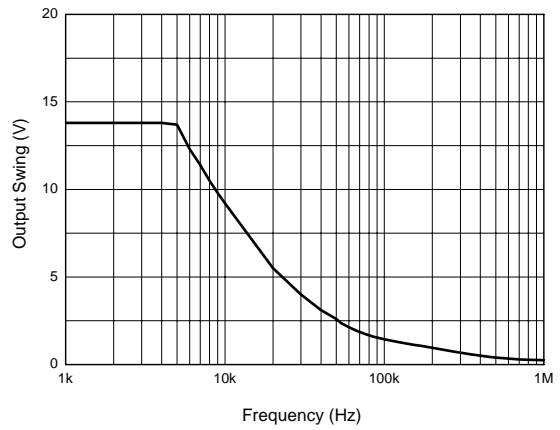

Figure 11. Large Signal Frequency Response

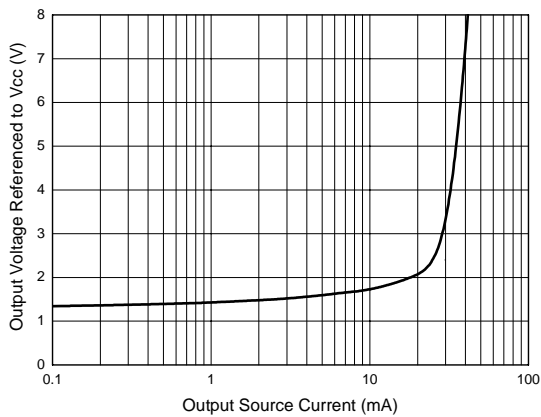

Figure 12. Output Characteristics: Current Sourcing

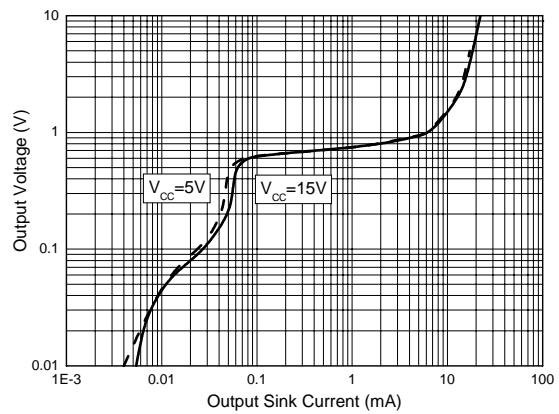

Figure 13. Output Characteristics: Current Sinking



LOW POWER SINGLE OPERATIONAL AMPLIFIER

AS321

Typical Performance Characteristics (Continued)

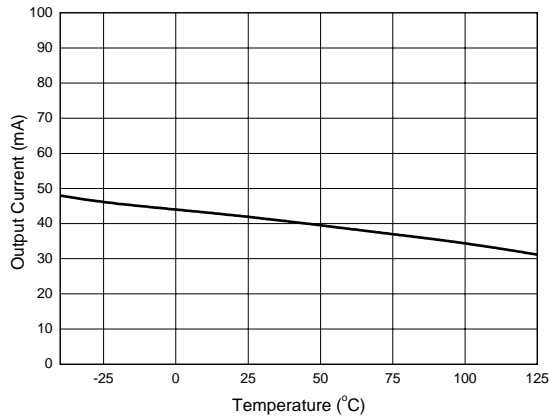

Figure 14. Current Limiting

Typical Application

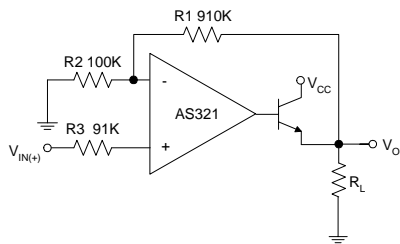

Figure 16. Power Amplifier

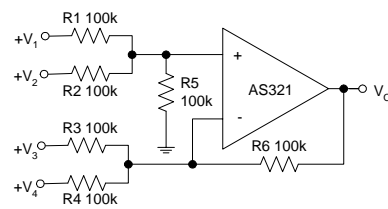

Figure 17. DC Summing Amplifier



LOW POWER SINGLE OPERATIONAL AMPLIFIER

AS321

Typical Application (Continued)

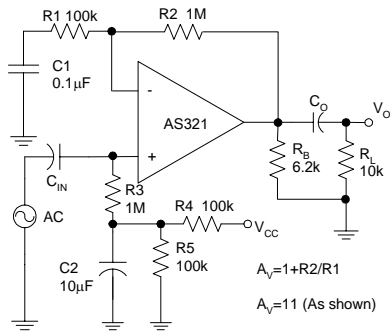

Figure 18. AC Coupled Non-Inverting Amplifier

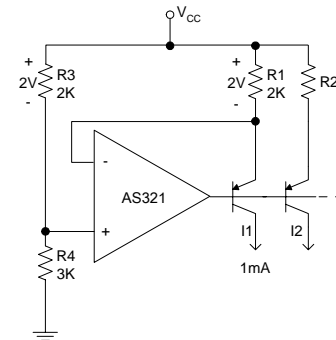

Figure 19. Fixed Current Sources

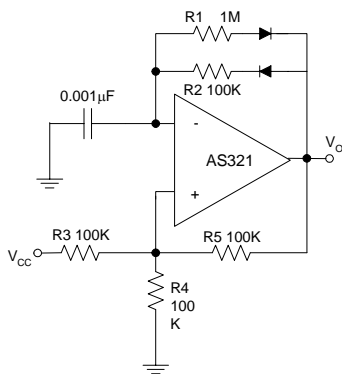

Figure 20. Pulse Generator

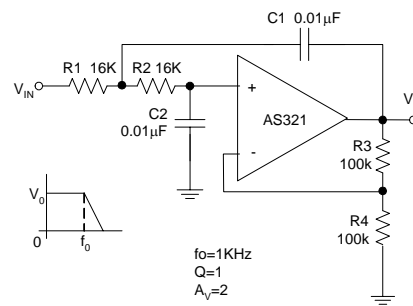

Figure 21. DC Coupled Low-Pass Active Filter



LOW POWER SINGLE OPERATIONAL AMPLIFIER

AS321

Mechanical Dimensions

SOT-23-5L

Unit: mm(inch)

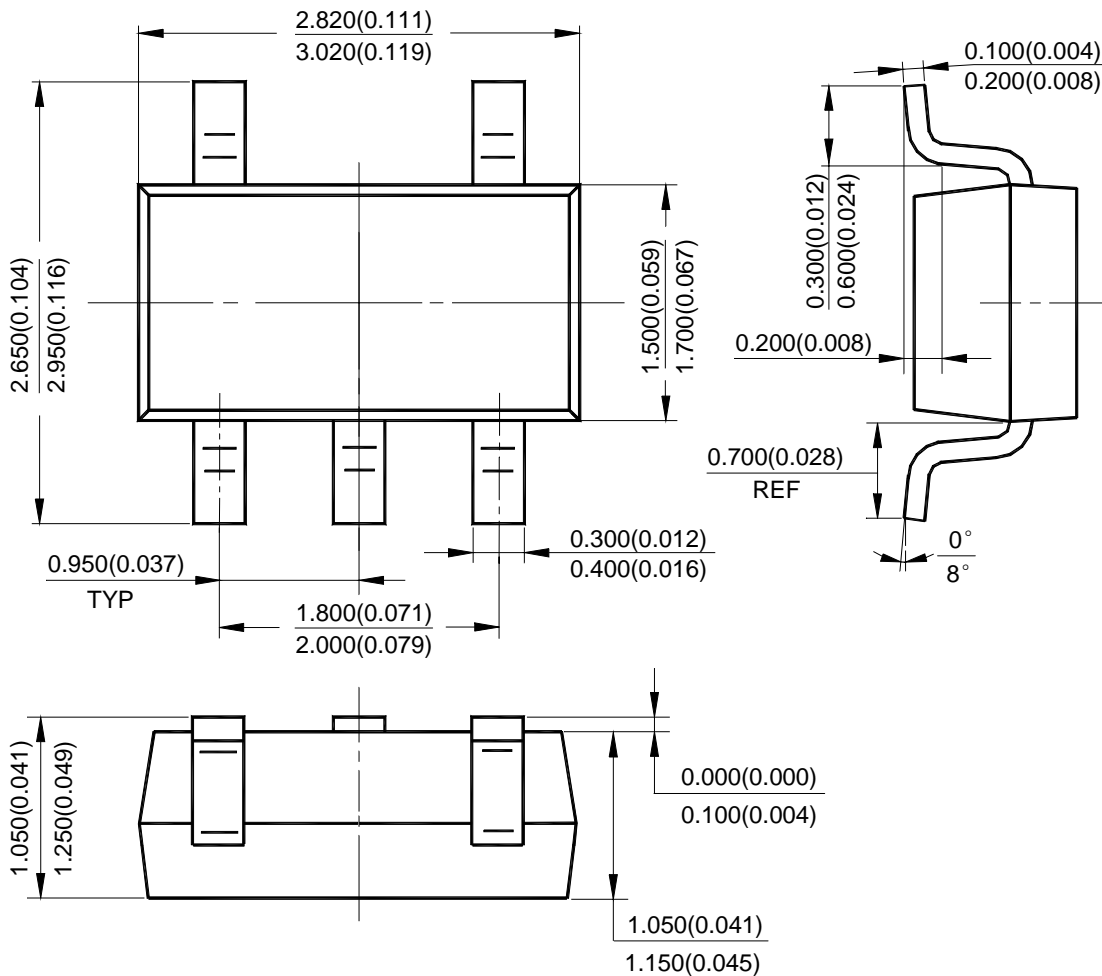



BCD Semiconductor Manufacturing Limited

<http://www.bcdsemi.com>

IMPORTANT NOTICE

BCD Semiconductor Manufacturing Limited reserves the right to make changes without further notice to any products or specifications herein. BCD Semiconductor Manufacturing Limited does not assume any responsibility for use of any its products for any particular purpose, nor does BCD Semiconductor Manufacturing Limited assume any liability arising out of the application or use of any its products or circuits. BCD Semiconductor Manufacturing Limited does not convey any license under its patent rights or other rights nor the rights of others.

MAIN SITE

BCD Semiconductor Manufacturing Limited
- Wafer Fab
Shanghai SIM-BCD Semiconductor Manufacturing Limited
800, Yi Shan Road, Shanghai 200233, China
Tel: +86-21-6485 1491, Fax: +86-21-5450 0008

BCD Semiconductor Manufacturing Limited
- IC Design Group
Advanced Analog Circuits (Shanghai) Corporation
8F, Zone B, 900, Yi Shan Road, Shanghai 200233, China
Tel: +86-21-6495 9539, Fax: +86-21-6485 9673

REGIONAL SALES OFFICE

Shenzhen Office
Shanghai SIM-BCD Semiconductor Manufacturing Co., Ltd. Shenzhen Office
Advanced Analog Circuits (Shanghai) Corporation Shenzhen Office
27B, Tower C, 2070, Middle Shen Nan Road, Shenzhen 518031, China
Tel: +86-755-8368 3987, Fax: +86-755-8368 3166

Taiwan Office
BCD Semiconductor (Taiwan) Company Limited
4F, 298-1, Rui Guang Road, Nei-Hu District, Taipei,
Taiwan
Tel: +886-2-2656 2808, Fax: +886-2-2656 2806

USA Office
BCD Semiconductor Corporation
3170 De La Cruz Blvd., Suite 105, Santa Clara,
CA 95054-2411, U.S.A
Tel: +1-408-988 6388, Fax: +1-408-988 6386