

## General Description

The AS3653 device is a highly integrated solution for power supply generation and monitoring, battery management including charging and SIM card communication. It is controlled via a serial control interface and integrates all necessary system specific functions such as clock, reset and interrupt generation, voltage and temperature monitoring, accessory detection and On/Off control.

## Key Features

### Supply Voltage Generation

- 1 Analogue High Current LDO (1.85...3.4V, 250mA)
- 1 Analogue Low Noise LDO (1.85...3.4V, 150mA)
- 1 Analogue Low Noise LDO (1.85...3.4V, 100mA)
- 2 RF Low Noise LDOs (1.85...3.4V, 100mA)
- 1 Analogue Low Noise LDO (1.85...3.4V, 10mA)
- 3 Digital Low Power LDOs (150mA)
- 1 SIM Card Supply LDO (1.8 / 3.0V, 20mA)
- 1 Low Noise, High PSRR Microphone Bias Generator

### Complete Chemistry Independent Charger

- Autonomous Trickle Charge Mode with 60min Timeout
- Programmable Constant Current Charging
- Programmable Constant Voltage / Pulse Charging
- Integrated Gas Gauge
- Overvoltage protection: Battery and Charger Voltage
- Operation without battery
- Battery presence indication
- Programmable backup battery charger

### SIM Card Interface

- Transparent SIM Card Interface with signal level translators and enhanced ESD protection

### System Control

- Clock Generation including low power 32kHz crystal oscillator
- RTC with Alarm Function
- Programmable Reset Generation for System Controller
- Programmable Interrupt Controller
- Programmable Battery Voltage Monitor
- Temperature Sensor to prevent failure of the device due to excess power dissipation
- 2 programmable Accessory Recognition Input Pins
- On/Off Control Module
- Programmable Watchdog Module

- 2 General Purpose Pulse Width Modulator (PWM) Outputs with programmable frequency and duty cycle
- 2 General Purpose LED Pattern Generator Outputs with programmable pattern and repetition period
- 8 General Purpose Input / Output Pins

- Wide Battery Supply Range 3.0...5.5V
- Serial Control Interface
- On-Chip Bandgap Tuning for High Accuracy ( $\pm 1\%$ )
- Excess Current and Thermal Protection
- 0.35 $\mu$ m CMOS Solution
- QFN48 package

## Applications

- Power Management Unit for GSM Mobile Phones
- 1 Cell Li+ or 3...4 Cell NiMH powered devices

# 1 Block Diagram

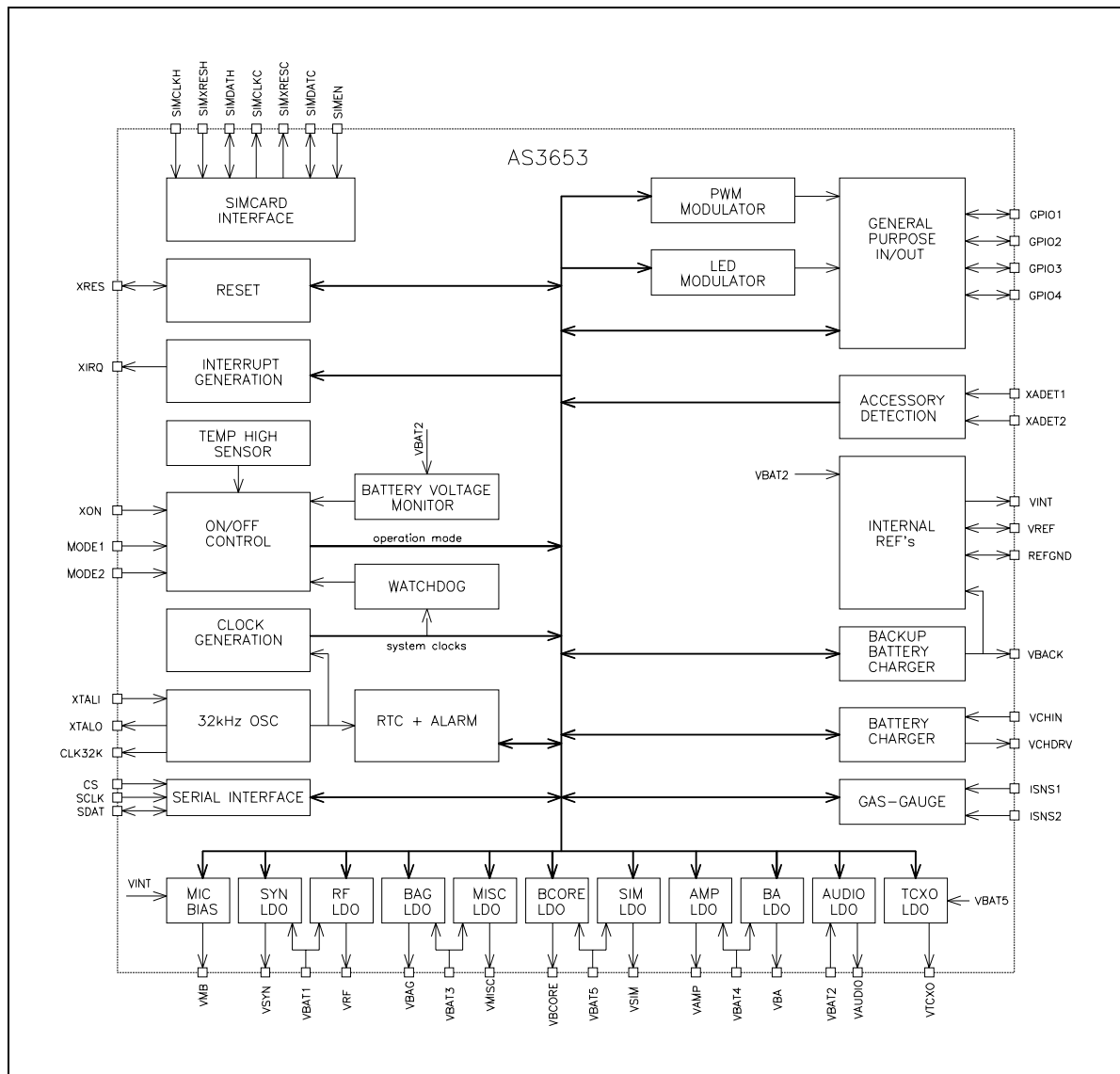

www.DataSheet4U.com