

AS3682

480mA Camera Lighting Management Unit

1 General Description

The AS3682 is a low-noise, high-current charge pump designed for camera flash LEDs and LCD backlighting applications. The device is capable of driving up to 480mA of load current.

The AS3682 integrates two independent LED blocks for driving a single flash LED (CURR₁₁ to CURR₁₃) with up to 480mA, and general purpose LEDs (CURR₂ to CURR₄) with up to 160mA/LED. The general purpose LEDs are controlled individually and can be used for backlighting, but also in support of an RGB fun-light or a movie indicator lamp.

The AS3682 utilizes austriamicrosystems' patent-pending Intelligent Adaptive Mode Setting (IAMS) to switch between 1:1, 1:1.5, and 1: 2 modes. In combination with very-low-drop-out current sinks, the device achieves high efficiency over the full single-cell Li+ battery voltage range. The charge pump operates at a fixed frequency of 1MHz allowing for tiny external components and its design ensures low EMI and low input-ripple.

The ultra-flexible brightness control scheme allows for simple adaptation of the device to different system architectures.

In Normal and Soft Flash Modes the device is controlled by an I²C interface. In these modes the LED brightness, flash duration, GPIOs and various charge pump states are controlled by internal register settings. The GPIO pins can act as programmable input or output pins and can also be set to trigger preview and flash light directly by a camera module.

In Hard Flash Mode, the LED brightness is controlled by the Enable pins. Those programming pins can be used as simple enable pins, as PWM input, again offering ample flexibility for setting the LED brightness.

2 Key Features

- High-Efficiency High-Power Charge Pump
 - 1:1, 1:1.5, and 1:2 Intelligent Adaptive Mode Setting (IAMS)
 - Efficiency up to 95%
 - Soft Start to Reduce Inrush Current
 - Low-Noise Constant-Frequency Operation
- Current Sinks
 - 400mA Continuous Flash Current (@V_{IN} = 3.2 to 5V, V_{OUT} = 5V)
 - 480mA Maximum Pulsed Flash Current
 - Programmable: 0 to 160mA, 0.625mA Resolution
- Flexible Brightness Control
 - Three 0 to 160mA LEDs
 - Individually Addressable via I²C Interface
- Three Operating Modes
 - Normal Mode (I²C Interface)
 - Soft Flash Mode (I²C Interface)
 - Dedicated Control Pins for Hard Flash Modes
- Two General Purpose Inputs/Outputs
 - Digital Input, Output, and Tristate
 - Programmable Pull-Up and Pull-Down
 - Strobe Pin can be used for Camera Flash Control
- LED Disconnect in Shutdown
- Open LED Detection
- Low Stand-By Current (6μA), Interface Fully Operating
- Low Shut-Down Current (0.2μA)
- Wide Battery Supply Range: 3.0 to 5.5V
- Thermal Protection
- 24-Pin, Small Form-Factor QFN Package
 - 4 x 4 x 0.85mm, 0.5mm Pitch
 - Enhanced Thermal Characteristics

3 Applications

Lighting management for cameras, mobile telephones, PDAs, and other 1-cell Li+ or 3-cell NiMH powered devices.

4 Block Diagram

Figure 1. AS3682 Block Diagram

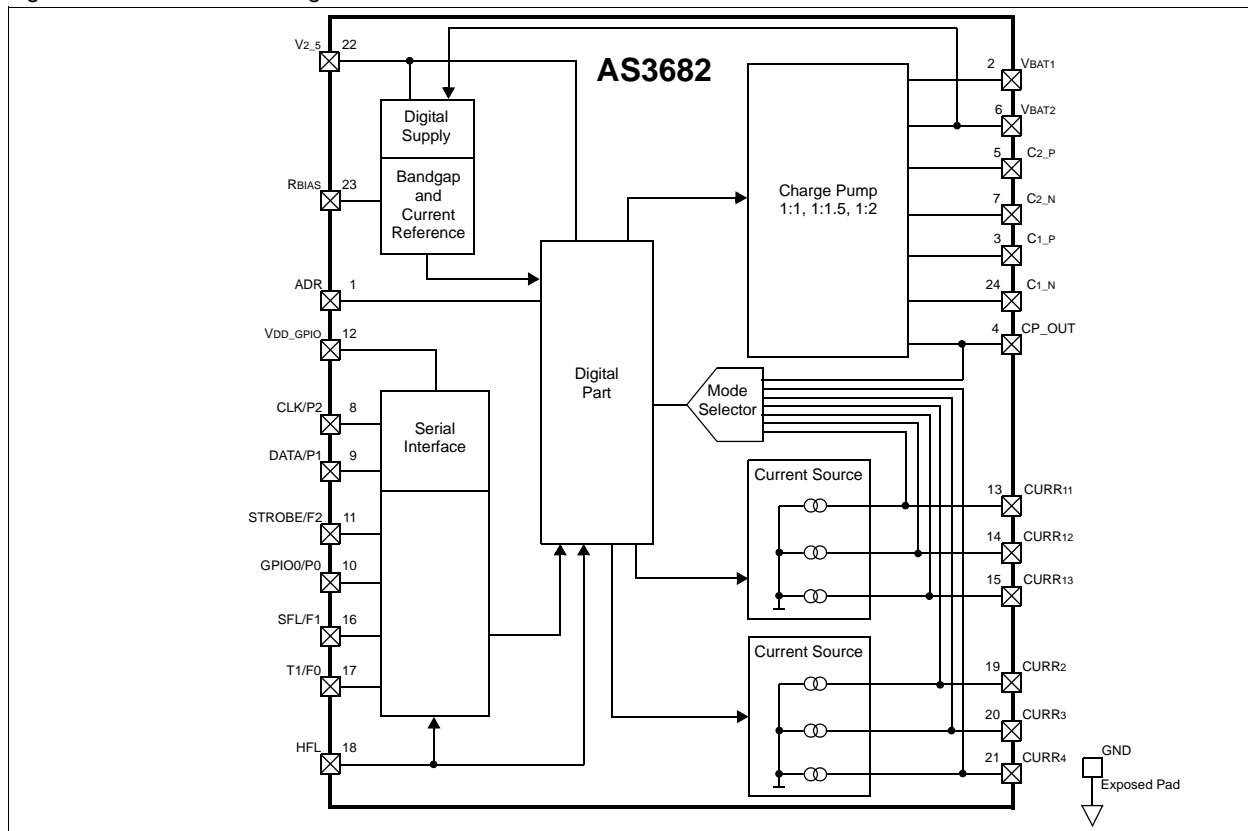

5 Application Diagrams

Figure 2. Normal and Soft Flash Mode Application Diagram

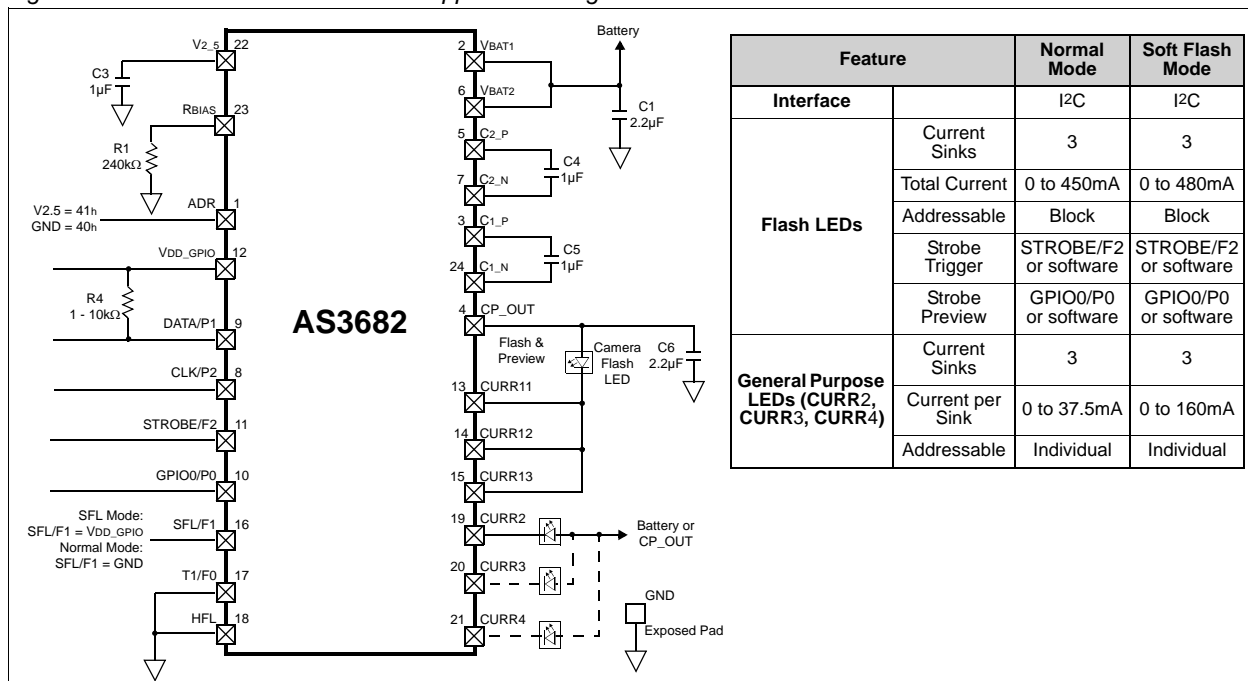

Figure 3. Hard Flash Mode 1 Application Diagram

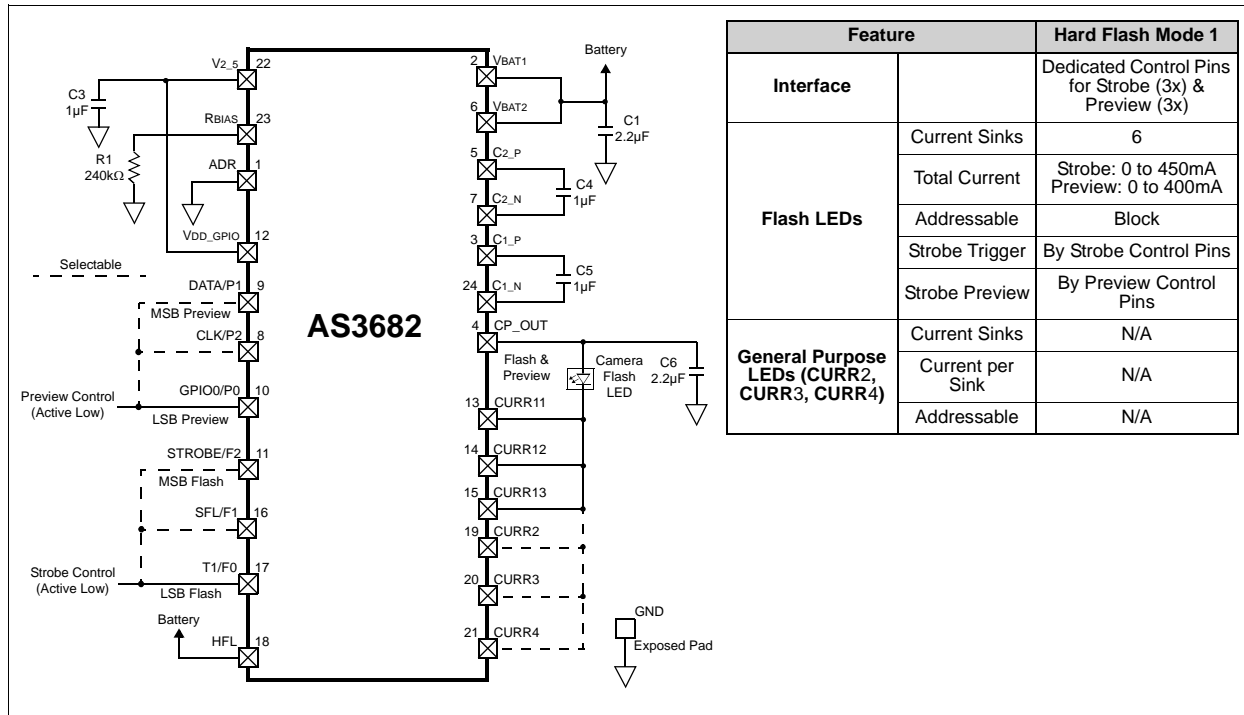
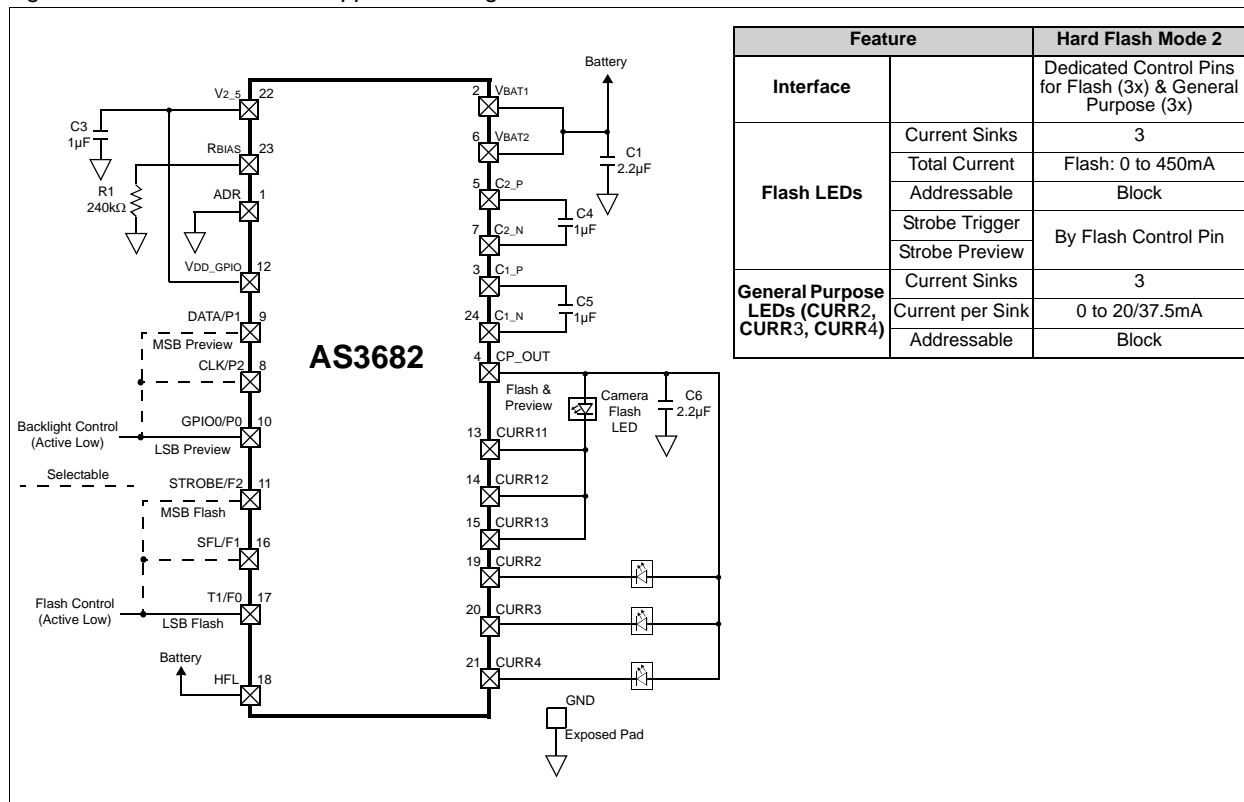

Figure 4. Hard Flash Mode 2 Application Diagram



Revision History

Revision	Date	Owner	Description
2.1	10 February 2005	ptr	- Various minor updates implemented.
2.2	16 August 2005	ptr	- Updated exposed pad size (D2 x E2). - Updated parameter V_{IH} max value. - Updated parameter V_{IL} max value. - Added parameter V_{POR_VBAT} min and max values. - Added bit Curr234_gpio0_ctrl (page 29). - Added bit Curr234_strobe_ctrl (page 29). - Added Fixed ID Register (Addr: 15).
2.21	6 July 2006	ptr	- Updated gpio0_pulls bit settings. - Updated strobe_pulls bit settings. - Updated data sheet status to public viewable.

Table of Contents

1	General Description	1
2	Key Features	1
3	Applications	1
4	Block Diagram	2
5	Application Diagrams	2
6	Characteristics	6
6.1	Absolute Maximum Ratings (Non-Operating)	6
6.2	Operating Conditions	6
6.3	Electrical Characteristics	7
7	Typical Operation Characteristics	9
8	Detailed Functional Descriptions	11
8.1	Charge Pump	11
8.1.1	Intelligent Adaptive Mode Switching (IAMS)	11
8.1.2	Soft Start	11
8.1.3	Open LED Detection	11
9	Mode Settings	12
10	Hard Flash Modes	14
10.1	Hard Flash Mode 1	15
10.2	Hard Flash Mode 2	17
11	Normal and Soft Flash Modes	19
11.1	Current Settings in Normal Mode	20
11.2	Current Settings in Soft Flash Mode	23
11.3	Timing Control of CURR ₁₁ , CURR ₁₂ , CURR ₁₃ in Normal Mode and Soft Flash Mode	24
11.4	Control of CURR ₂ , CURR ₃ , CURR ₄ in Normal Mode and Soft Flash Mode	29
11.5	Charge Pump Control Registers	30
11.6	General Purpose Inputs/Outputs	31
11.7	Power-On Reset	32
11.8	Temperature Supervision	32
11.9	Serial Interface	33
11.9.1	Features	33
11.9.2	Device Address Selection	33
11.9.3	Data Transfer Formats	33
11.9.4	Fixed ID Register	35
11.10	Register Map	36
12	External Components	37
12.1	Capacitor and Resistor Selection	37
12.2	Usage of PCB Wire Inductance	37
12.3	External Component Specifications	37
13	Pinout and Packaging	38
13.1	Hard Flash Modes Pin Descriptions	38
13.2	Normal Mode and Soft Flash Mode Pin Descriptions	39
13.3	Package Drawings and Markings	40
14	Ordering Information	42

6 Characteristics

6.1 Absolute Maximum Ratings (Non-Operating)

Stresses beyond those listed in Table 1 may cause permanent damage to the device. These are stress ratings only, and functional operation of the device beyond those indicated in Table 2 is not implied.

Caution: Exposure to absolute maximum rating conditions may affect device reliability.

Table 1. Absolute Maximum Ratings

Symbol	Parameter	Min	Max	Unit	Notes
VIN_MV	5V Pins	-0.3	7.0	V	Applicable for 5V pins ¹
VIN_LV	3.3V Pins	-0.3	5.0, VDD_GPIO + 0.3	V	Applicable for 3.3V pins ²
IIN	Input Pin Current	-25	+25	mA	At 25°C, Norm: Jedec 17
TSTRG	Storage Temperature Range	-55	125	°C	
	Humidity	5	85	%	Non condensing
VESD	Electrostatic Discharge	-1000	1000	V	Norm: MIL 883 E Method 3015
PT	Total Power Dissipation		1	W	TAMB = 70°
TBODY	Body Temperature		260	°	IPC/JEDEC J-STD-020C

Notes:

- 5V pins are VBAT1, VBAT2, HFL, current sink pins (CURR11, CURR12, CURR13, CURR2, CURR3, and CURR4) and the charge pump pins (C1_N, C2_N, C1_P, C2_P, and CP_OUT).
- 3.3V pins are GPIO0/P0, STROBE/F2, interface pins (CLK/P2, DATA/P1, ADR) and all other pins.

6.2 Operating Conditions

Table 2. Operating Conditions

Symbol	Parameter	Min	Typ	Max	Unit	Notes
VBAT	Battery Voltage	3.0	3.6	5.5	V	VBAT1 and VBAT2
VDD_GPIO	Periphery Supply Voltage	1.5		3.3	V	
V2_5	Voltage on Pin V2_5	2.4	2.5	2.6	V	Internally generated; Hard Flash Mode: always on; Soft Flash Mode: always on except in shutdown.
TAMB	Ambient Temperature	-30	25	85	°C	
IBAT	Operating Current			1	A	Depending on load current and charge pump mode.
ISTANDBY	Standby Mode Current		6	10.5	µA	Current consumption in standby mode; Only 2.5V regulator on; temperature supervision off. VDD_GPIO (page 8) > VGPIO_Vdd_TH_RISING (page 8).
	Standby Mode Current including Temperature Supervision		8	14.5	µA	Current consumption in standby mode; Only 2.5V regulator on and temperature supervision on. VDD_GPIO > VGPIO_Vdd_TH_RISING. This is also the minimum current consumption in Hard Flash Mode.
ISHUTDOWN	Shutdown Mode Current		0.2	1.5	µA	Current consumption in shutdown mode; VDD_GPIO < 0.3v.

6.3 Electrical Characteristics

Table 3. Charge Pump Electrical Characteristics

Symbol	Parameter	Min	Typ	Max	Unit	Notes
VCPOUT	Output Voltage Without Load			$V_{BAT} \times$ CP-mode	V	Internally regulated.
	Output Limitation		5.3	5.6	V	
	Output Voltage With Load ($I = 400\text{mA}$)			3.32		
			4.31			1:1.5 Mode; $V_{BAT} = 3.5\text{V}$
			5.24			1:2 Mode; $V_{BAT} = 3.5\text{V}$
RCP	Charge Pump Effective Resistance		0.5		Ω	1:1 Mode; $V_{BAT} = 3.0\text{V}$, $I_{LOAD} = 400\text{mA}$
			2.6			1:1.5 Mode; $V_{BAT} = 3.0\text{V}$, $I_{LOAD} = 400\text{mA}$
			2.5			1:2 Mode; $V_{BAT} = 3.0\text{V}$, $I_{LOAD} = 400\text{mA}$
ICPOUT	Continuous Output Current			400	mA	In automatic mode only; $V_{BAT} \leq 4.2\text{V}$.
ICP	Power Consumption Without Load, $f_{CLK} = 1\text{MHz}$		0.1		mA	1:1 mode
			4.5			1:1.5 mode
			5			1:2 mode
Eta_1	Efficiency ¹	75		93	%	$V_{IN} = 3.0$ to 4.5V , $I_{OUT} = 100\text{mA}$
Eta_2	Efficiency ²	65		82	%	$V_{IN} = 3.0$ to 4.5V , $I_{OUT} = 10$ to 350mA
tR	Rising Time			1.0	ms	
VORIP	Output Ripple		10		mVpp	$V_{IN} = 3.0$ to 4.5V , $I_{OUT} = 350\text{mA}$, $C_P = 2.2\mu\text{F}$, X5R
fCLK	Clock Frequency	-20%	1.0	20%	MHz	

Notes:

1. This parameter describes the efficiency of the charge pump only.

Table 4. Current Sink Electrical Characteristics

Symbol	Parameter	Min	Typ	Max	Unit	Notes
ICURR1x-MAX	CURR1x Maximum Output Current		150		mA	Normal Mode
			160			Soft Flash Mode
			150			Hard Flash Mode
ICURR1x-RES	CURR1x Resolution		15		mA	Normal Mode low range ($I < 240\text{mA}$)
			30			Normal Mode high range ($I > 240\text{mA}$)
			0.625			Soft Flash Mode
			20			Hard Flash Mode
ICURR2,3,4-MAX	CURR2,3,4 Maximum Output Current		37.5		mA	Normal Mode
			160			Soft Flash Mode
			150			Hard Flash Mode
ICURR2,3,4-RES	CURR2,3,4 Resolution		2.5		mA	Normal Mode
			0.625			Soft Flash Mode
			20			Hard Flash Mode
Delta-abs	Absolute Accuracy	-20		+20	%	All current sinks
Delta-rel	Relative Accuracy		5		%	
VPROTECT	Voltage Above V_{BAT} for Protection			$V_{BAT} + 2.0$	V	$I_{SINK} \geq 20\text{mA}$
VCOMPL	Voltage Compliance	0.2		$V_{BAT} + 0.5$	V	During normal operation
V_LOW	Under-Voltage Detection	50	150	200	mV	

Table 5. GPIO/P0 and STROBE/F2 Electrical Characteristics

Symbol	Parameter	Min	Max	Unit	Notes
VDD_GPIO	Supply Voltage	1.5	3.3	V	
VIH	High Level Input Voltage	0.7 x VDD_GPIO	VDD_GPIO	V	VDD_GPIO > 1.85V
		1.3V			VDD_GPIO < 1.85V
VIL	Low Level Input Voltage	0.0	0.3 x VDD_GPIO	V	
VHYS	Hysteresis	0.1 x VDD_GPIO	0.4	V	
I _{LEAK}	Input Leakage Current (if not configured as Pullup/Pulldown)	-5	5	μA	To VDD_GPIO and Vss.
I _{PD}	Pulldown Current (if configured as Pulldown)	50	150	μA	To Vss.
I _{PU}	Pullup Current (if configured as Pullup and in Hard Flash Modes)	20	347	μA	To VDD_GPIO (1.5 to 3.3V)
VOH	High Level Output Voltage	0.8 x VDD_GPIO		V	
VOL	Low Level Output Voltage		0.2 x VDD_GPIO	V	
I _{OUT}	Driving Capability	4		mA	VDD_GPIO = 2.8V
C _{LOAD}	Capacitive Load		50	pF	

Table 6. CLK/P2, DATA/P1, SFL/F1, and T1/F0 Electrical Characteristics

Symbol	Parameter	Min	Max	Unit	Notes
VDD_GPIO	Supply Voltage	1.5	3.3	V	
VIH	High Level Input Voltage	0.7 x VDD_GPIO	VDD_GPIO	V	VDD_GPIO > 1.85V
		1.3V			VDD_GPIO < 1.85V
VIL	Low Level Input Voltage	0.0	0.3 x VDD_GPIO	V	
VHYS	Hysteresis	0.07 x VDD_GPIO	0.5	V	
I _{LEAK}	Input Leakage Current (in Soft Flash and Normal Modes)	-5	5	μA	To VDD_GPIO and Vss.
I _{PU}	Pullup Resistor (in Hard Flash Modes)	50k	200k	Ω	To VDD_GPIO.

Table 7. Power-On Reset Electrical Characteristics

Symbol	Parameter	Min	Typ	Max	Unit	Notes
V _{POR_VBAT}	Overall Power-On Reset	1.5	2.0	2.38	V	Monitors voltage on pin V _{2_5} ; power-on reset for all internal functions.
V _{VDD_GPIO_TH_RISING}	Reset Level for VDD_GPIO Rising		1.3		V	Monitors voltage on VDD_GPIO; rising level.
V _{VDD_GPIO_TH_FALLING}	Reset Level for VDD_GPIO Falling		1.0		V	Monitors voltage on VDD_GPIO; falling level.

Table 8. Over-Temperature Detection Electrical Characteristics

Symbol	Parameter	Min	Typ	Max	Unit	Notes
T ₁₄₀	ov_temp Rising Threshold	130	140	150	°C	
THYST	ov_temp Hysteresis		5		°C	

7 Typical Operation Characteristics

Figure 5. Efficiency vs. V_{BAT} (with 1 Flash LED, Type LumiLed PWF-1)

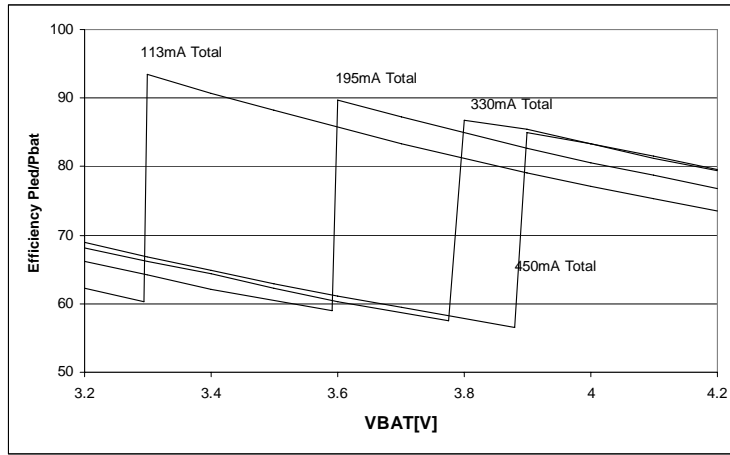

Figure 6. Battery Current vs. V_{BAT} (with 1 Flash LED, Type LumiLed PWF-1)

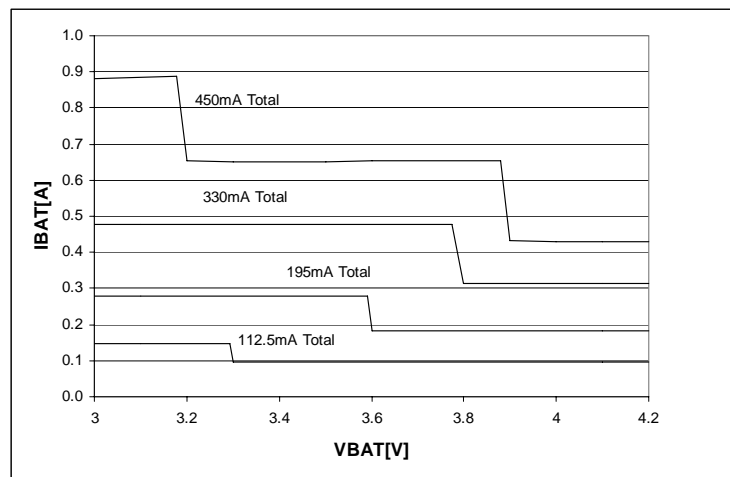

Figure 7. Efficiency vs. V_{BAT} (with 1 Flash LED, Type Osram LWW5SG LED)

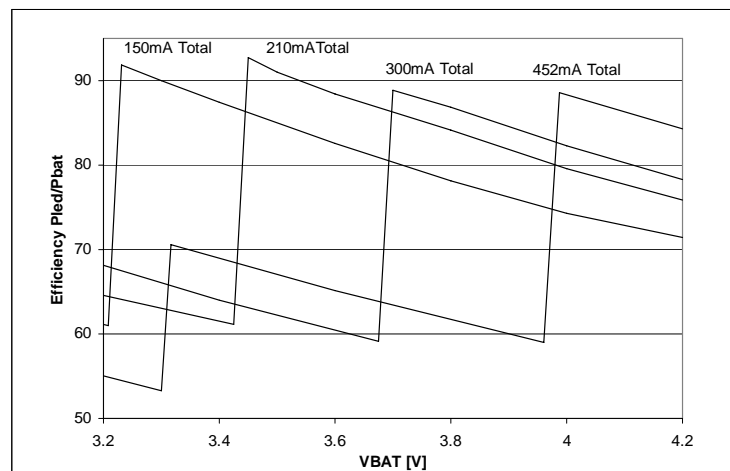

Figure 8. Battery Current vs. V_{BAT} (with 1 Flash LED, Type Osram LWW5SG LED)

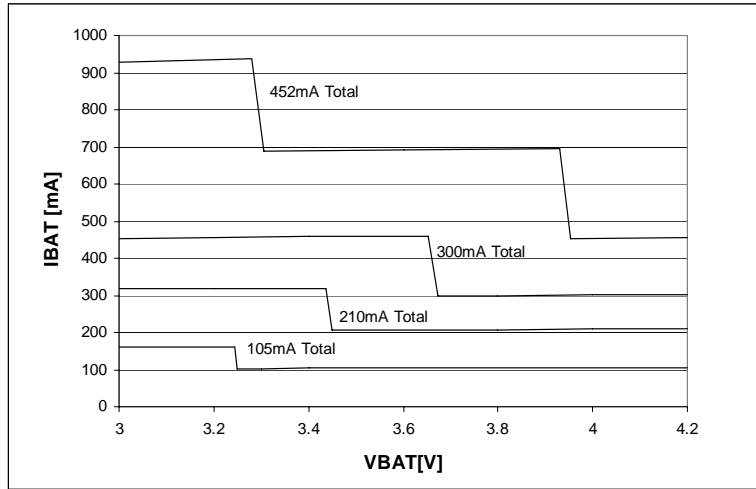
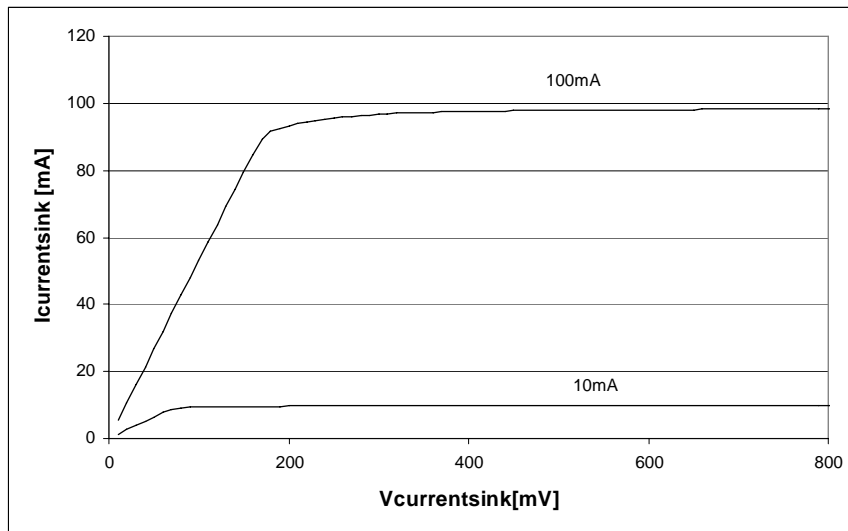

Figure 9. Linearity of 1 Current Sink with 10mA and 100mA Load



8 Detailed Functional Descriptions

8.1 Charge Pump

The AS3682 charge pump uses two external flying capacitors to generate output voltages higher than the battery voltage.

The charge pump can operate in three different modes:

- **1:1 Bypass Mode**
 - Battery input and output are connected by a low-impedance switch
 - Battery current = output current
- **1:1.5 Mode**
 - The output voltage is 1.5 times the battery voltage (without load)
 - Battery current = 1.5 times output current
- **1:2 Mode**
 - The output voltage is 2 times the battery voltage (without load)
 - Battery current = 2 times output current

8.1.1 Intelligent Adaptive Mode Switching (IAMS)

The integrated charge pump determines the best compromise between the required LED supply voltage (V_f) and the lowest internal power dissipation. The AS3682 examines the voltage at each current sink and automatically switches into a higher charge pump mode; the switch-down procedure is achieved after the AS3682 performs analog signal processing of all relevant parameters: the battery voltage, the actual charge pump voltage, the load current, and the resistance of the next charge pump mode. By predicting the efficiency of the next state, the AS3682 will accurately determine the switching point.

8.1.2 Soft Start

An implemented soft start mechanism reduces the inrush current. Battery current is smoothed when switching the charge pump on and also at each switching condition. This precaution reduces electromagnetic radiation significantly.

8.1.3 Open LED Detection

The voltages at the current sinks are used to determine the mode switching of the charge pump up, thus an open wire to the LED could lead to a high-power dissipation of the circuit.

The AS3682 scans and compares all voltages on the current sinks continuously, so that if the charge pump is already at 1:2 mode and the required current cannot be provided, the circuit stops that current sink sensing until the next power-on condition. Using the circuit via the I²C interface (Normal Mode and Soft Flash Mode) the system can get information on the failing path from the **GPIO_output** (page 31) register.

Scanning occurs automatically upon first entering 1:2 mode.

9 Mode Settings

The AS3682 can operate in four different application modes which can be easily selected either by external pins or will be factory preset.

- **Normal Mode** – The AS3682 is fully programmable via an I²C interface allowing for access to all control registers. The maximum total Flash Current of 450mA can be set in 15 or 30mA steps. Preview and strobe timing can be controlled either by internal registers or by dedicated pins (STROBE/F2, GPIO0/P0) connected to the BB or a camera module. The 3 Flash LED current sinks can only be addressed as a single block.
The three General Purpose LED current sinks can be addressed individually allowing for the realization of Back-lighting, Movie Indicator LEDs or an RGB Fun Light or can be connected to the Flash LED. The maximum current per sink is 37.5mA whereas the current can be set in 2.5mA steps per channel.
- **Soft Flash Mode** – The AS3682 is fully programmable via an I²C interface allowing for access to all control registers. The maximum total Flash Current of 480mA can be set in 1.875mA steps. Preview and strobe timing can be controlled either by internal registers or by dedicated pins (STROBE/F2, GPIO0/P0) connected to the BB or a Camera Module. The 3 Flash LED current sinks can only be addressed as a single block.
The three General Purpose LED current sinks can be addressed individually allowing for the realization of Back-lighting, Movie Indicator LEDs or an RGB Fun Light or can be connected to the Flash LED. The maximum current per sink is 160mA whereas the current can be set in 2.5mA steps per channel.
- **Hard Flash Mode 1** – All AS3682 functions are controlled by dedicated Enable Pins. Seven different current levels can be set independently for Preview and Flash by the Preview pins (GPIO0/P0, DATA/P1, CLK/P2) and the Flash pins (T1/F0, SFL/F1, STROBE/F2). The maximum total current is 450mA for strobe and 240mA for preview when connecting 3 current sinks to the LED. Since Hard Flash Mode 1 addresses all 6 current sinks, higher preview and strobe currents can be programmed, however the total absolute maximum current must not exceed 480mA.
- **Hard Flash Mode 2** – All AS3682 functions are controlled by dedicated Enable Pins. The three Flash Current sinks (Curr11, Curr12, Curr13) act as a single block being controlled by the Flash control pins (T1/F0, SFL/F1, STROBE/F2). The maximum total Flash current of 450mA can be adjusted in 60mA steps.
The three General Purpose LED current sinks (Curr11, Curr12, Curr13) can be addressed independently from the Flash LEDs by dedicated pins (GPIO0/P0, DATA/P1, CLK/P2). The current per-sink can be adjusted in 6 levels up to 20mA per channel with a resolution of 2.5mA. A seventh level allows for a maxim of 37.5mA which can be used

to address e.g., six white LEDs. After presetting the current with the dedicated pins the actual brightness can also be adjusted by PWM applied to the related pins.

Note: The Hard Flash Modes are factory preset. Refer to Ordering Information on page 42.

Table 9. AS3682 Function Settings

Feature		Normal Mode	Soft Flash Mode	Hard Flash Mode 1	Hard Flash Mode 2
Interface		I2C	I2C	Dedicated Control Pins for Strobe (3x) and Preview (3x)	Dedicated Control Pins for Flash (3x) and General Purpose (3x)
Flash LEDs	Current Sinks	3	3	6	3
	Total Current	0 to 450mA	0 to 480mA	Strobe: 0 to 450mA Preview: 0 to 400mA	Flash: 0 to 450mA
	Addressable	Block	Block	Block	Block
	Strobe Trigger	STROBE/F2 or software	STROBE/F2 or software	By Strobe Control Pins	By Flash Control Pin
	Strobe Preview	GPIO0/P0 or software	GPIO0/P0 or software	By Preview Control Pins	
General Purpose LEDs (CURR₂, CURR₃, CURR₄)	Current Sinks	3	3	N/A	3
	Current per Sink	0 to 37.5mA	0 to 160mA	N/A	0 to 20/37.5mA
	Addressable	Individual	Individual	N/A	Block

Note: The AS3682 has been designed and qualified for the following operating conditions:

- Continuous output current of 400mA if operated in automatic switch mode at V_{BAT} = 3.2 to 4.2V.
- Maximum Pulsed Output current: 480mA.

10 Hard Flash Modes

The Hard Flash Modes allow for simple and efficient control of the AS3682 using dedicated Enable Pins. While the Hard Flash Mode can be selected by defined pin connections (see Table 10 Hard Flash Mode Setting by Pin Configuration) the distinction between Hard Flash Mode 1 and Hard Flash Mode 2 is set by the factory (refer to Ordering Information on page 42 for more information).

An integrated temperature sensor provides over-temperature protection for the AS3682. If the device temperature exceeds the value of T_{140} (page 8), the current sources will be switched off. The device will resume operation when the temperature drops below $T_{140} - T_{HYST}$ (page 8).

- Hard Flash Mode 1 (page 15) Allows for individual control of Strobe and Preview Signals or in other words Flash and Torch engaging all 6 current sinks.
- Hard Flash Mode 2 (page 17) Addresses the Flash LEDs and General Purpose LEDs independently of each other providing the possibility to realize Flash and Backlight Functions in parallel.

Note: In both Hard Flash Modes pins STROBE/F2, SFL/F1, T1/F0, CLK/P2, DATA/P1, and GPIO0/P0 are Active-Low (with internal pull-up resistors).

Hard Flash Modes 1 and 2 are factory preset. See Ordering Information on page 42.

Table 10. Hard Flash Mode Setting by Pin Configuration

Pin HFL	Pin SFL/F1	Mode
GND	GND	Normal Mode
GND	VDD_GPIO	Soft Flash Mode
VBAT	Don't Care	Hard Flash Mode

10.1 Hard Flash Mode 1

Table 11. Hard Flash Mode 1 Functions

Feature		Hard Flash Mode 1	Hard Flash Mode 2
Interface		Dedicated Control Pins for Strobe (3x) and Preview (3x)	Dedicated Control Pins for Flash (3x) and General Purpose (3x)
Flash LEDs	Current Sinks	6	3
	Total Current	Strobe: 0 to 450mA Preview: 0 to 400mA	Flash: 0 to 450mA
	Total Current Resolution	Strobe: 60mA Preview: 30mA	Flash: 60mA
	Addressable	Block	Block
	Strobe Trigger	By Strobe Control Pins	By Flash Control Pin
	Strobe Preview	By Preview Control Pins	
General Purpose LEDs (CURR₂, CURR₃, CURR₄)	Current Sinks	N/A	3
	Current per Sink	N/A	0 to 20/37.5mA
	Addressable	N/A	Block

Figure 10. Hard Flash Mode 1 Functional Diagram

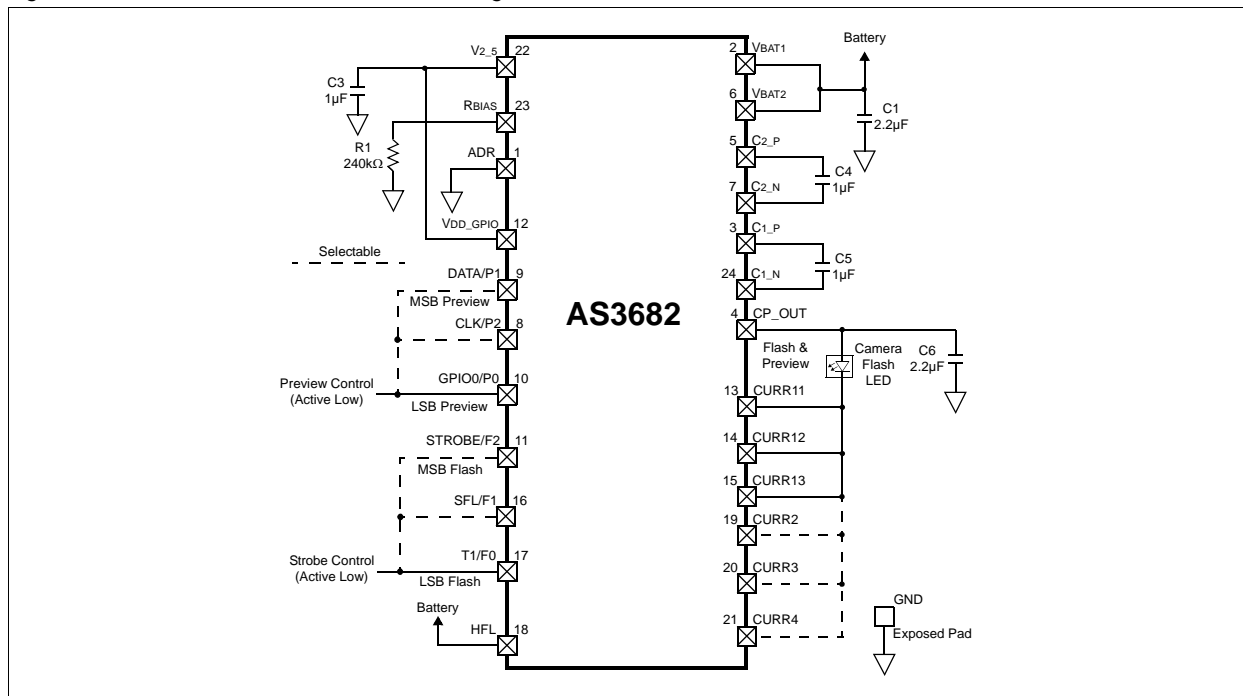

Figure 11. Hard Flash Mode 1 Timing Diagram

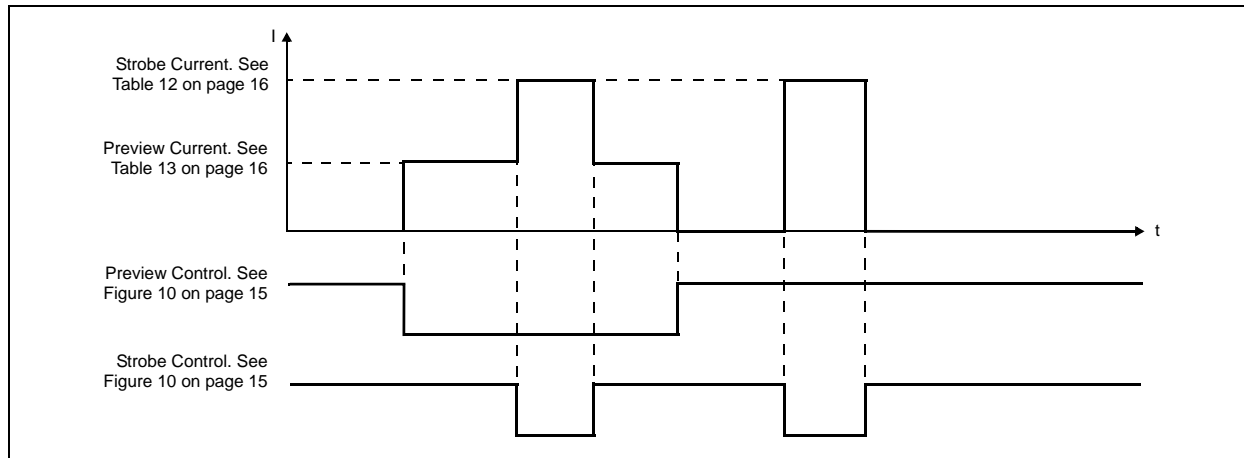

Table 12. Hard Flash Mode 1 Strobe Current

STROBE/ F2 Bit 2	SFL/F1 Bit 1	T1/F0 Bit 0	Current/ Current Sink	Cumulative Active Current Sink ¹					
				CURR ₁₁	CURR ₁₂	CURR ₁₃	CURR ₂	CURR ₃	CURR ₄
1	1	1	0mA	0mA	0mA	0mA	0mA	0mA	0mA
1	1	0	30mA	30mA	60mA	90mA	120mA	150mA	180mA
1	0	1	50mA	50mA	100mA	150mA	200mA	250mA	300mA
1	0	0	70mA	70mA	140mA	210mA	280mA	350mA	420mA
0	1	1	90mA	90mA	180mA	270mA	360mA	450mA	540mA
0	1	0	110mA	110mA	220mA	330mA	440mA	550mA	660mA
0	0	1	130mA	130mA	260mA	390mA	520mA	650mA	780mA
0	0	0	150mA	150mA	300mA	450mA	600mA	750mA	900mA

Notes:

1. Do not exceed maximum current of 480mA.

Table 13. Hard Flash Mode 1 Preview Current

CLK/P2 Bit 2	DATA/P1 Bit 1	GPIO/P0 Bit 0	Current/ Current Sink	Cumulative Active Current Sink					
				CURR ₁₁	CURR ₁₂	CURR ₁₃	CURR ₂	CURR ₃	CURR ₄
1	1	1	0mA	0mA	0mA	0mA	0mA	0mA	0mA
1	1	0	20mA	20mA	40mA	60mA	80mA	100mA	120mA
1	0	1	30mA	30mA	60mA	90mA	120mA	150mA	180mA
1	0	0	40mA	40mA	80mA	120mA	160mA	200mA	240mA
0	1	1	50mA	50mA	100mA	150mA	200mA	250mA	300mA
0	1	0	60mA	60mA	120mA	180mA	240mA	300mA	360mA
0	0	1	70mA	70mA	140mA	210mA	280mA	350mA	420mA
0	0	0	80mA	80mA	160mA	240mA	320mA	400mA	480mA

Note: Do not exceed maximum current of 400mA in Preview Mode (continuous operation).

The AS3682 allows for the parallel connection of up to six current sinks to obtain the desired current range in Hard Flash Mode (unused current sinks can be left open). For example, to obtain 280mA for Preview current, connect CURR₁₁, CURR₁₂, CURR₁₃, and CURR₂ together and set CLK/P2 and DATA/P1 = 0 and GPIO/P0 = 1.

10.2 Hard Flash Mode 2

Table 14. Hard Flash Mode 2 Functions

Feature		Hard Flash Mode 1	Hard Flash Mode 2
Interface		Dedicated Control Pins for Strobe (3x) and Preview (3x)	Dedicated Control Pins for Flash (3x) and General Purpose (3x)
	Current Sinks	6	3
Flash LEDs	Total Current	Strobe: 0 to 450mA Preview: 0 to 400mA	Flash: 0 to 450mA
	Total Current Resolution	Strobe: 60mA Preview: 30mA	Flash: 60mA
	Addressable	Block	Block
	Strobe Trigger	By Strobe Control Pins	By Flash Control Pin
	Strobe Preview	By Preview Control Pins	
General Purpose LEDs (CURR2, CURR3, CURR4)	Current Sinks	N/A	3
	Current per Sink	N/A	0 to 20/37.5mA
	Addressable	N/A	Block

Figure 12. Hard Flash Mode 2 Functional Diagram

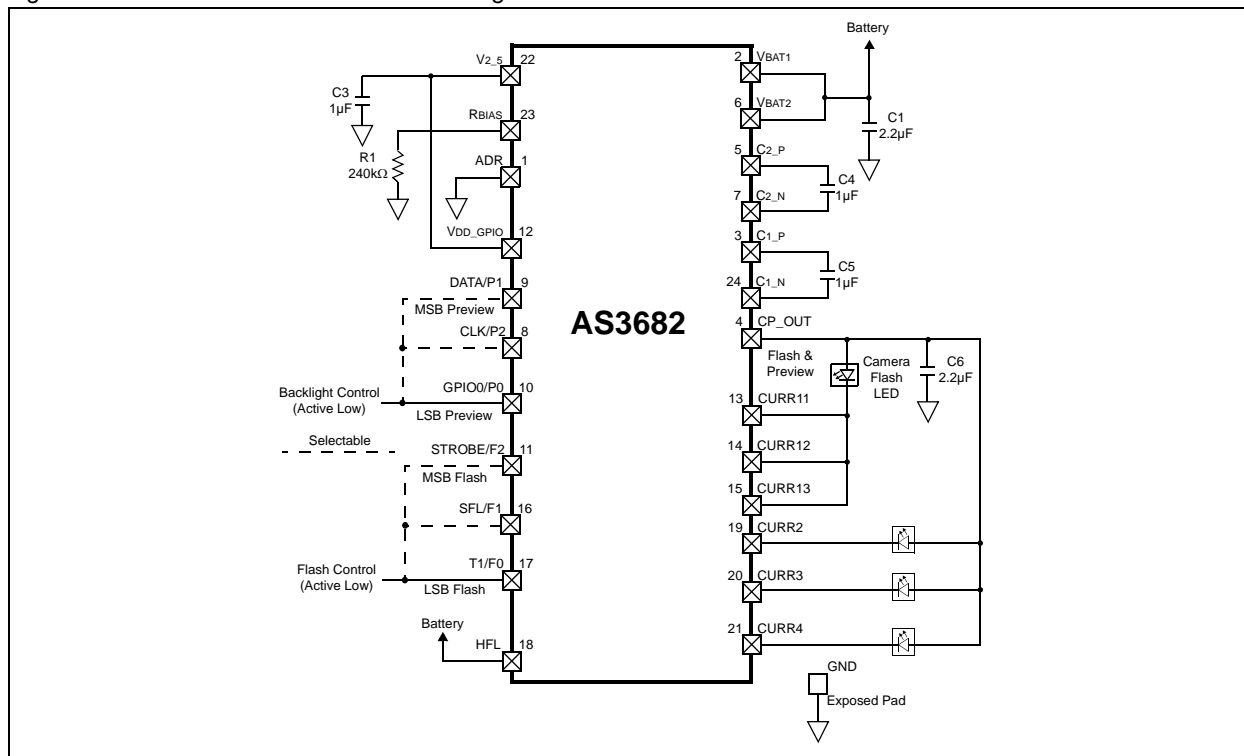

Figure 13. Hard Flash Mode 2 Timing Diagram

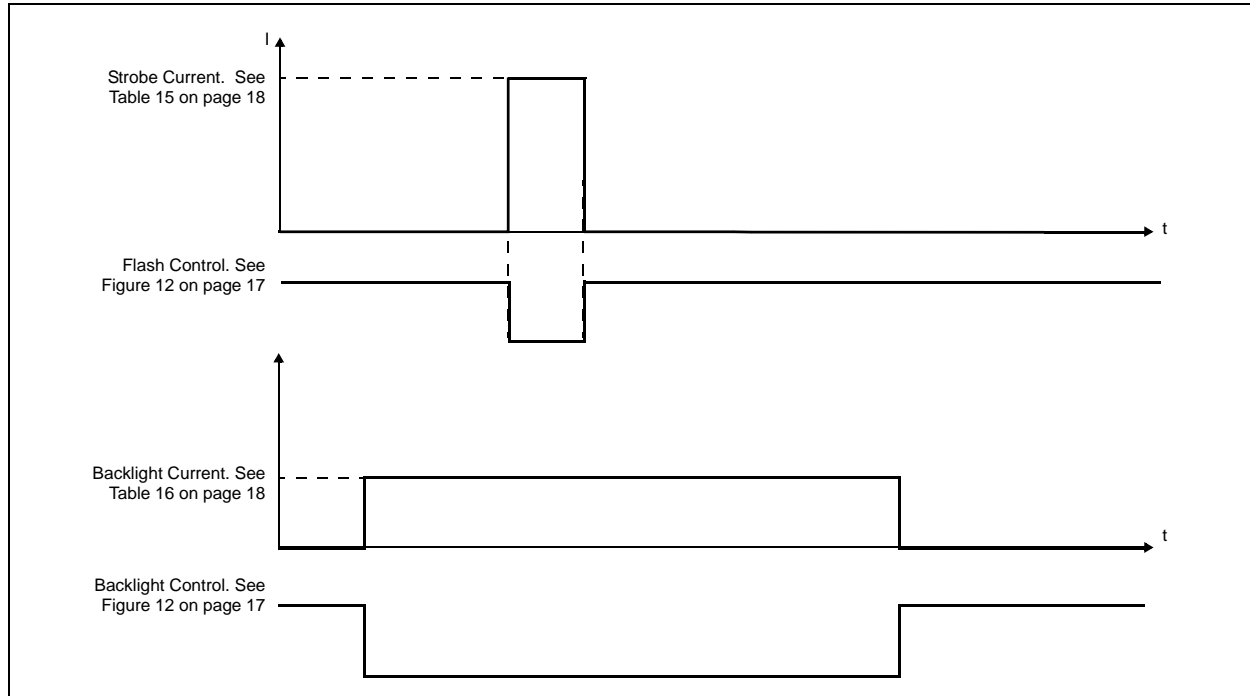

Table 15. Hard Flash Mode 2 Strobe Current

STROBE/F2 Bit 2	SFL/F1 Bit 1	T1/F0 Bit 0	Current/ Current Sink	Cumulative Active Current Sink (CURR ₁₁ , CURR ₁₂ , CURR ₁₃)		
				11	12	13
1	1	1	0mA	0mA	0mA	0mA
1	1	0	30mA	30mA	60mA	90mA
1	0	1	50mA	50mA	100mA	150mA
1	0	0	70mA	70mA	140mA	210mA
0	1	1	90mA	90mA	180mA	270mA
0	1	0	110mA	110mA	220mA	330mA
0	0	1	130mA	130mA	260mA	390mA
0	0	0	150mA	150mA	300mA	450mA

The AS3682 allows for the parallel connection of up to three current sinks in Hard Flash Mode to obtain the desired current range for the strobe current (unused current sinks can be left open).

Table 16. Hard Flash Mode 2 Backlight Current

CLK/P2 Bit 2	DATA/P1 Bit 1	GPIO0/P0 Bit 0	Current/Current Sink (CURR ₂ , CURR ₃ , CURR ₄)
1	1	1	0mA
1	1	0	5mA
1	0	1	7mA
1	0	0	10mA
0	1	1	12mA
0	1	0	15mA
0	0	1	17mA
0	0	0	37mA

11 Normal and Soft Flash Modes

Table 17. Normal and Soft Flash Mode Settings

Pin HFL	Pin SFL/F1	Mode
GND	GND	Normal Mode
GND	VDD_GPIO	Soft Flash Mode
VBAT	Don't Care	Hard Flash Mode

Table 18. Normal Mode and Soft Flash Mode Functions

Feature		Normal Mode	Soft Flash Mode
Interface		I2C	I2C
	Flash LEDs		
Flash LEDs	Current Sinks	3	3
	Total Current	0 to 450mA	0 to 480mA
	Total Current Resolution	4-Bit: 15/30mA	8-Bit: 1.875mA
	Addressable	Block	Block
	Strobe Trigger	Pin STROBE/F2 (active high) or software	Pin STROBE/F2 (active low) or software
	Strobe Preview	Pin GPIO0/P0 (active high) or software	Pin GPIO0/P0 (active low) or software
General Purpose LEDs (CURR2, CURR3, CURR4)	Current Sinks	3	3
	Current per Sink	0 to 37.5mA	0 to 160mA
	Current Resolution per Sink	4-Bit: 2.5mA	8-Bit: 0.625mA
	Addressable	Individual	Individual

Figure 14. Normal Mode and Soft Flash Mode Functional Diagram

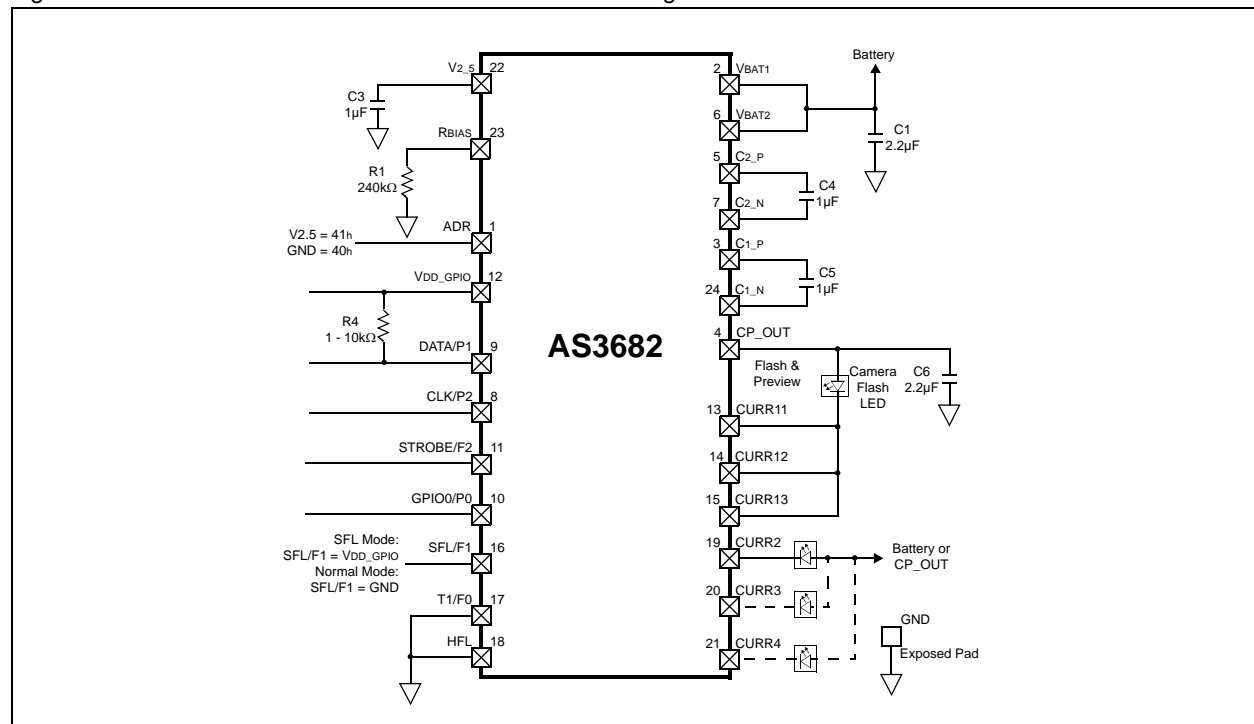

11.1 Current Settings in Normal Mode

Table 19. Current Sink_1x Preview Current Definition Register

Addr: 01		Current1_preview							
		This register sets the current values of the current sinks used during preview.							
Bit	Bit Name	Default	Access	Description					
0	curr_hp	0	R/W	Used with bits current1_preview.					
3:1	N/A								
7:4	current1_preview	0	R/W					curr_hp = 0	curr_hp = 1
				MSB (Bit 7)			LSB (Bit 4)	mA	mA
				0	0	0	0	0	0
				0	0	0	1	15	30
				0	0	1	0	30	60
				0	0	1	1	45	90
				0	1	0	0	60	120
				0	1	0	1	75	150
				0	1	1	0	90	180
				0	1	1	1	105	210
				1	0	0	0	120	240
				1	0	0	1	135	270
				1	0	1	0	150	300
				1	0	1	1	165	330
				1	1	0	0	180	360
				1	1	0	1	195	390
1	1	1	0	210	420				
1	1	1	1	225	450				

Table 20. Current Sink_1x Strobe Current Definition Register

Addr: 02		Current1_strobe							
		This register sets the current values of the current sinks used during strobe.							
Bit	Bit Name	Default	Access	Description					
0	curr_hs	0	R/W	Used with bits current1_strobe.					
3:1	N/A								
7:4	current1_strobe	0	R/W					curr_hs = 0	curr_hs = 1
				MSB (Bit 7)			LSB (Bit 4)	mA	mA
				0	0	0	0	0	0
				0	0	0	1	15	30
				0	0	1	0	30	60
				0	0	1	1	45	90
				0	1	0	0	60	120
				0	1	0	1	75	150
				0	1	1	0	90	180
				0	1	1	1	105	210
				1	0	0	0	120	240
				1	0	0	1	135	270
				1	0	1	0	150	300
				1	0	1	1	165	330
				1	1	0	0	180	360
				1	1	0	1	195	390
1	1	1	0	210	420				
1	1	1	1	225	450				

Table 21. Current Sink2,3,4 Control Registers

Addr: 06		Current2						
		This register sets the current values of the CURR2. Any value not equal 0 activates the sink.						
Bit	Bit Name	Default	Access	Description				
3:0	Current2	0h	R/W	MSB (Bit 3)			LSB (Bit 0)	mA
				0	0	0	0	0.0
				0	0	0	1	2.5
				0	0	1	0	5.0
				0	0	1	1	7.5
				0	1	0	0	10.0
				0	1	0	1	12.5
				0	1	1	0	15.0
				0	1	1	1	17.5
				1	0	0	0	20.0
				1	0	0	1	22.5
				1	0	1	0	25.0
				1	0	1	1	27.7
				1	1	0	0	30.0
				1	1	0	1	32.5
1	1	1	0	35.0				
1	1	1	1	37.5				
7:4	N/A							
Addr: 07		Current3						
		This register sets the current values of CURR3. Any value not equal 0 activates the sink.						
Bit	Bit Name	Default	Access	Description				
3:0	Current3	0h	R/W	MSB (Bit 3)			LSB (Bit 0)	mA
				0	0	0	0	0.0
				0	0	0	1	2.5
				0	0	1	0	5.0
				0	0	1	1	7.5
				0	1	0	0	10.0
				0	1	0	1	12.5
				0	1	1	0	15.0
				0	1	1	1	17.5
				1	0	0	0	20.0
				1	0	0	1	22.5
				1	0	1	0	25.0
				1	0	1	1	27.7
				1	1	0	0	30.0
				1	1	0	1	32.5
1	1	1	0	35.0				
1	1	1	1	37.5				
7:4	N/A							

Addr: 08		Current4						
		This register sets the current values of CURR4. Any value not equal 0 activates the sink.						
Bit	Bit Name	Default	Access	Description				
				MSB (Bit 3)			LSB (Bit 0)	mA
				0	0	0	0	0.0
				0	0	0	1	2.5
				0	0	1	0	5.0
				0	0	1	1	7.5
				0	1	0	0	10.0
				0	1	0	1	12.5
				0	1	1	0	15.0
				0	1	1	1	17.5
				1	0	0	0	20.0
				1	0	0	1	22.5
				1	0	1	0	25.0
				1	0	1	1	27.7
				1	1	0	0	30.0
				1	1	0	1	32.5
				1	1	1	0	35.0
				1	1	1	1	37.5
7:4	N/A							

11.2 Current Settings in Soft Flash Mode

Table 22. Current Sink_1x Preview Current Definition Register

Addr: 01		Current1_preview		
This register sets the current values of the current sinks CURR _{1x} used during preview.				
Bit	Bit Name	Default	Access	Description
7:0	current1_preview	0	R/W	00h = 0mA FFh = 160mA per current sink

Table 23. Current Sink_1x Strobe Current Definition Register

Addr: 02		Current1_strobe		
This register sets the current values of the current sinks CURR _{1x} used during strobe.				
Bit	Bit Name	Default	Access	Description
7:0	current1_strobe	0	R/W	00h = 0mA FFh = 160mA per current sink

Table 24. Current Sink_2 Control Register

Addr: 06		Current2		
This register sets the current values of current sink CURR ₂ . Any value ≠ 0 activates the sink. Exceptions are Curr234_gpio0_ctrl (page 29) and Curr234_strobe_ctrl (page 29).				
Bit	Bit Name	Default	Access	Description
7:0	current2	0	R/W	00h = 0mA FFh = 160mA

Table 25. Current Sink_3 Control Register

Addr: 07		Current3		
This register sets the current values of current sink CURR ₃ . Any value not-equal 0 activates the sink. Exceptions are Curr234_gpio0_ctrl (page 29) and Curr234_strobe_ctrl (page 29).				
Bit	Bit Name	Default	Access	Description
7:0	current3	0	R/W	00h = 0mA FFh = 160mA

Table 26. Current Sink_4 Control Register

Addr: 08		Current4		
This register sets the current values of current sink CURR ₄ . Any value not-equal 0 activates the sink. Exceptions are Curr234_gpio0_ctrl (page 29) and Curr234_strobe_ctrl (page 29).				
Bit	Bit Name	Default	Access	Description
7:0	current4	0	R/W	00h = 0mA FFh = 160mA

Caution: The total current of the charge pump (480mA) must not be exceeded.

11.3 Timing Control of CURR₁₁, CURR₁₂, CURR₁₃ in Normal Mode and Soft Flash Mode

Connecting the Current Sinks

The load of current sinks CURR₁₁, CURR₁₂, and CURR₁₃ must be connected to the charge pump output (CP_OUT).

Setting the Current Values

Current sinks CURR₁₁, CURR₁₂, and CURR₁₃ are all programmed by the same register settings (registers **current1_preview** (page 20) and **Current1_strobe** (page 20)). They should be connected in parallel (pins CURR₁₁, CURR₁₂, and CURR₁₃ must be connected externally) to increase the driving capability, e.g., for a photo camera flash LED.

The current defined in these registers (**current1_preview** and **Current1_strobe**) is the total current, which means each current sink contributes one-third of the preset current value.

Turning the Current Sinks On/Off in Preview Mode

The current sinks in preview mode are controlled programmatically by bit **preview_on** (page 25) or by pin GPIO0/P0. Bit **preview_on** defines which sink is selected.

Turning the Current Sinks On/Off in Strobe Mode

The current sinks in strobe mode are controlled by pin STROBE/F2. This signal is called STROBE_SIGNAL. The duration of the strobe current is dependent on the following parameters:

- In Mode 1 (selected by bit **Strobe_mode** (page 25)) the strobe current is started by the rising edge of the STROBE_SIGNAL. The duration of the strobe current is defined by the value in register **Strobe_mode1** (page 25) only. The minimum duration of the strobe current is 100ms, the maximum is 800ms.
- In Mode 2 (selected by bit **Strobe_mode** (page 25)) the strobe current is started by the rising edge of the STROBE_SIGNAL. The duration of the strobe current is dependent on the length of the STROBE_SIGNAL and the value in register **Strobe_mode2** (page 26).
If register **Strobe_mode2** setting = 000 to 111, strobe current stops with the falling edge of STROBE_SIGNAL but is limited to the value defined in the register (100ms to 800ms).
- In Mode 3 (selected by bit **Strobe_mode** (page 25)) the strobe current is started by the rising edge of the STROBE_SIGNAL and it stops with the falling edge of the STROBE_SIGNAL. In Mode 3 there is no limitation of the strobe time.

Table 27. Current Sink_1x Control Register

Addr: 00		Powerdown_control		
This register switches the charge pump and current sinks 1x on and off.				
Bit	Bit Name	Default	Access	Description
0	cp_led_on			See cp_led_on (page 30).
1	curr11_on	0	R/W	CURR ₁₁ enable/disable signal. 0 = Switch CURR ₁₁ off. 1 = Switch CURR ₁₁ on.
2	curr12_on	0	R/W	CURR ₁₂ enable/disable signal. 0 = Switch CURR ₁₂ off. 1 = Switch CURR ₁₂ on.
3	curr13_on	0	R/W	CURR ₁₃ enable/disable signal. 0 = Switch CURR ₁₃ off. 1 = Switch CURR ₁₃ on.
7:4	N/A			

Table 28. Current Sink_1x Mode and Control Registers

Addr: 03		Current1_control		
This register controls the function of the current sinks.				
Bit	Bit Name	Default	Access	Description
1:0	Strobe_mode	01b	R/W	00 = Strobe mode 1 is selected. The strobe time is defined by the value in register Strobe_mode1 (page 25) the maximum strobe time is limited to 800ms. 01 = Strobe mode 2 is selected. The strobe time is defined by the pulse length of the STROBE_SIGNAL and in addition it is affected by the setting of register Strobe_mode2 (page 26). 1x = Strobe mode 3 is selected. The strobe time is defined by the pulse length of STROBE_SIGNAL. The maximum strobe time is unlimited.
3:2	N/A			
4	preview_on	0	R/W	0 = Current of current sinks is 0mA. 1 = Current of current sinks is defined by register current1_preview . If preview is controlled via pin GPIO0/P0 (see bit preview_ctrl), this bit has no effect.
5	preview_ctrl	0	R/W	0 = Preview mode is controlled by bit preview_on (page 25). 1 = Preview mode is controlled by pin GPIO0/P0.
6	strobe_on	0	R/W	0 = Current of current sinks is 0mA. 1 = Current of current sinks is defined by register Current1_strobe (page 20). If preview mode is controlled via pin STROBE/F2 (see bit xstrobe_ctrl), this bit has no effect
7	xstrobe_ctrl	0	R/W	0 = Strobe mode is controlled by pin STROBE/F2. 1 = Strobe mode is controlled by bit strobe_on (page 25).
Addr: 04		Strobe_mode1		
This register sets the strobe time in mode 1.				
Bit	Bit Name	Default	Access	Description
2:0	Strobe_mode	001b	R/W	000 = Ts is equal to 100ms. 001 = Ts is equal to 200ms. 010 = Ts is equal to 300ms. 011 = Ts is equal to 400ms. 100 = Ts is equal to 500ms. 101 = Ts is equal to 600ms. 110 = Ts is equal to 700ms. 111 = Ts is equal to 800ms.
7:3	N/A			

www.DataSheet4U.com

Addr: 05		Strobe_mode2		
This register sets the strobe time in mode 2.				
Bit	Bit Name	Default	Access	Description
2:0	Mode2	111	R/W	000 = Ts is equal to TSTROBE_SIGNAL if T_STROBE_SIGNAL ≤ 100ms. 000 = Ts is equal to 100ms if T_STROBE_SIGNAL ≥ 100ms. 001 = Ts is equal to TSTROBE_SIGNAL if T_STROBE_SIGNAL ≤ 200ms. 001 = Ts is equal to 200ms if T_STROBE_SIGNAL ≥ 200ms. 010 = Ts is equal to TSTROBE_SIGNAL if T_STROBE_SIGNAL ≤ 300ms. 010 = Ts is equal to 300ms if T_STROBE_SIGNAL ≥ 300ms. 011 = Ts is equal to TSTROBE_SIGNAL if T_STROBE_SIGNAL ≤ 400ms. 011 = Ts is equal to 400ms if T_STROBE_SIGNAL ≥ 400ms. 100 = Ts is equal to TSTROBE_SIGNAL if T_STROBE_SIGNAL ≤ 500ms. 100 = Ts is equal to 500ms if T_STROBE_SIGNAL ≥ 500ms. 101 = Ts is equal to TSTROBE_SIGNAL if T_STROBE_SIGNAL ≤ 600ms. 101 = Ts is equal to 600ms if T_STROBE_SIGNAL ≥ 600ms. 110 = Ts is equal to TSTROBE_SIGNAL if T_STROBE_SIGNAL ≤ 700ms. 110 = Ts is equal to 700ms if T_STROBE_SIGNAL ≥ 700ms. 111 = Ts is equal to TSTROBE_SIGNAL if T_STROBE_SIGNAL ≤ 800ms. 111 = Ts is equal to 800ms if T_STROBE_SIGNAL ≥ 800ms.
7:3	N/A			

Table 29. Current Sink_1x Undervoltage Indication Register

Addr: 0F		Curr_voltage_control		
This register indicates if the voltage at any current sink has dropped below a predefined value. If the charge pump is operating in automatic-mode (default), the contents of this register can be disregarded. The voltages at current sinks 1x are used for automatic mode selection of the charge pump. The voltages at current sinks 2, 3, and 4 can be optionally used for automatic mode selection of the charge pump (see register Curr234_ctrl (page 29)).				
Bit	Bit Name	Default	Access	Description
0	curr11_low_voltage	N/A	R	0 = Normal operation. 1 = Undervoltage occurred.
1	curr12_low_voltage	N/A	R	0 = Normal operation. 1 = Undervoltage occurred.
2	curr13_low_voltage	N/A	R	0 = Normal operation. 1 = Undervoltage occurred.
3	Curr2_low_voltage	N/A	R	See Curr2_low_voltage (page 29).
4	Curr3_low_voltage	N/A	R	See Curr3_low_voltage (page 29).
5	Curr4_low_voltage	N/A	R	See Curr4_low_voltage (page 29).
7:6	cp_status	N/A	R	See cp_status (page 30).

Figure 15. Preview and Strobe Timing – Mode 1

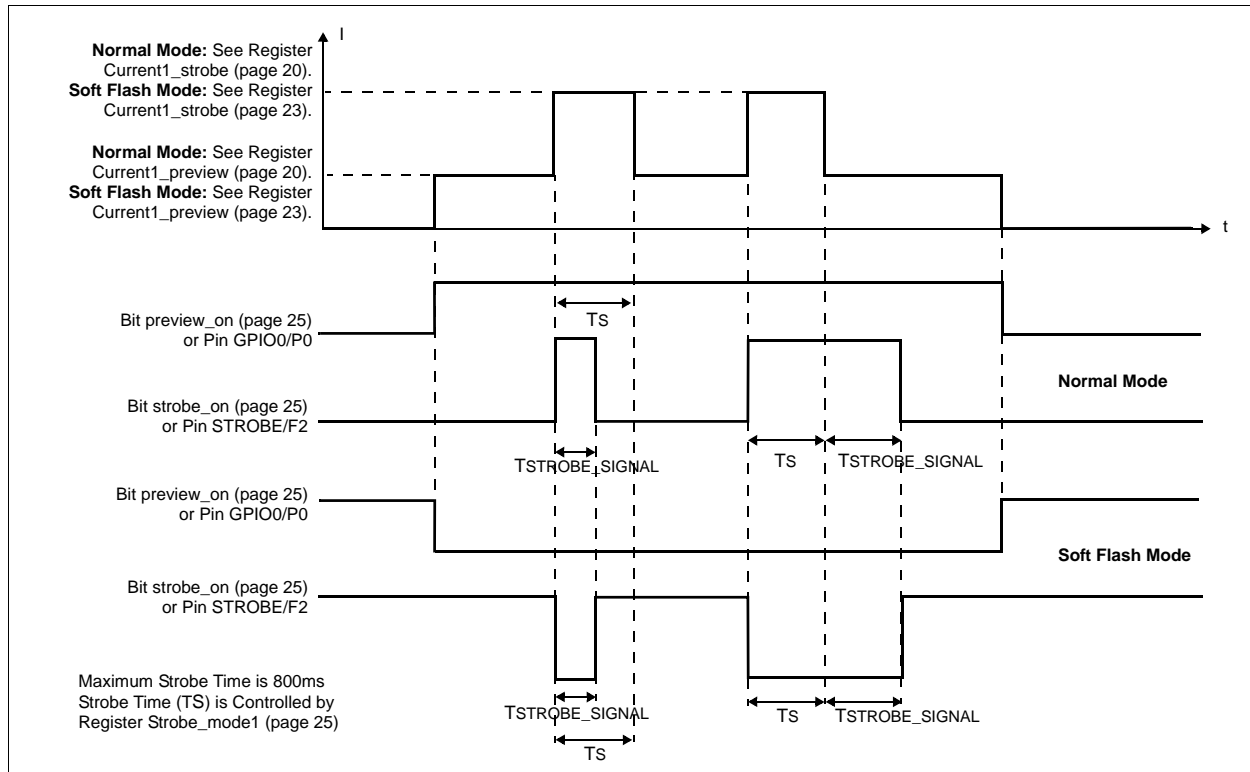

Figure 16. Preview and Strobe Timing – Mode 2

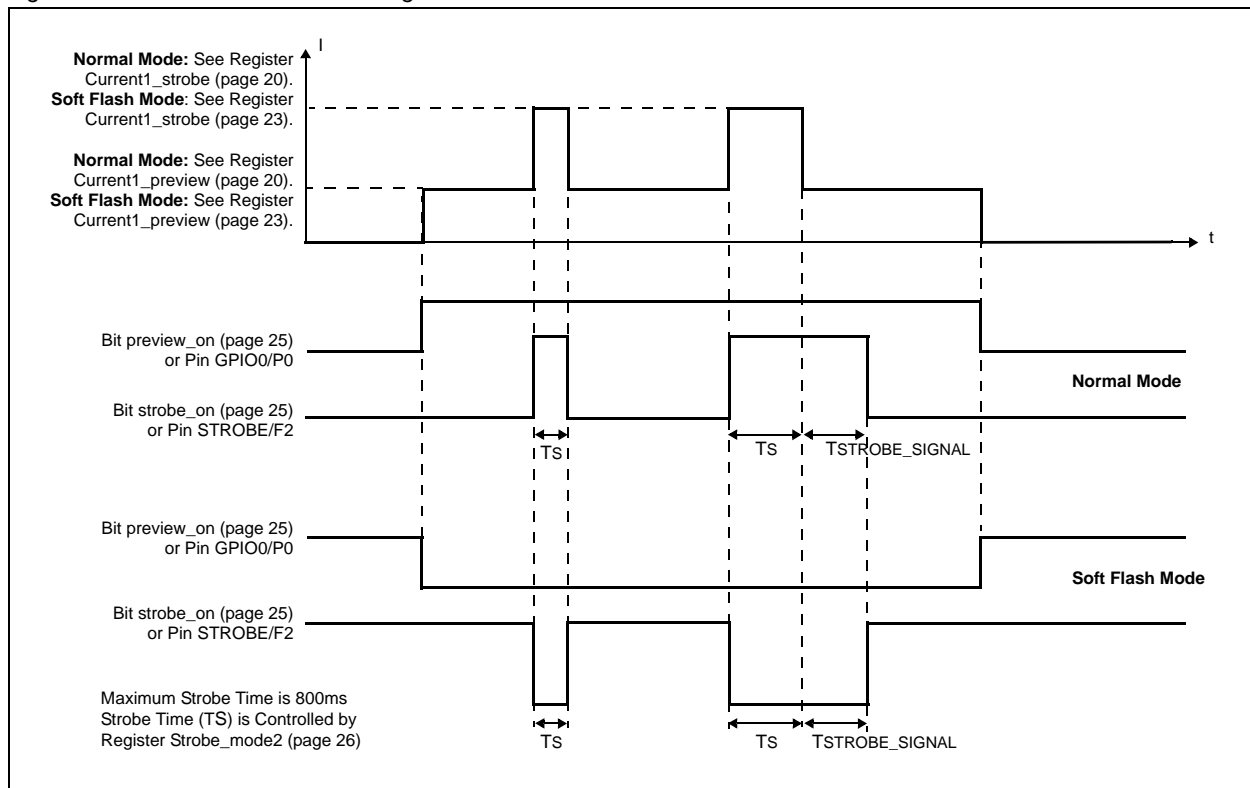
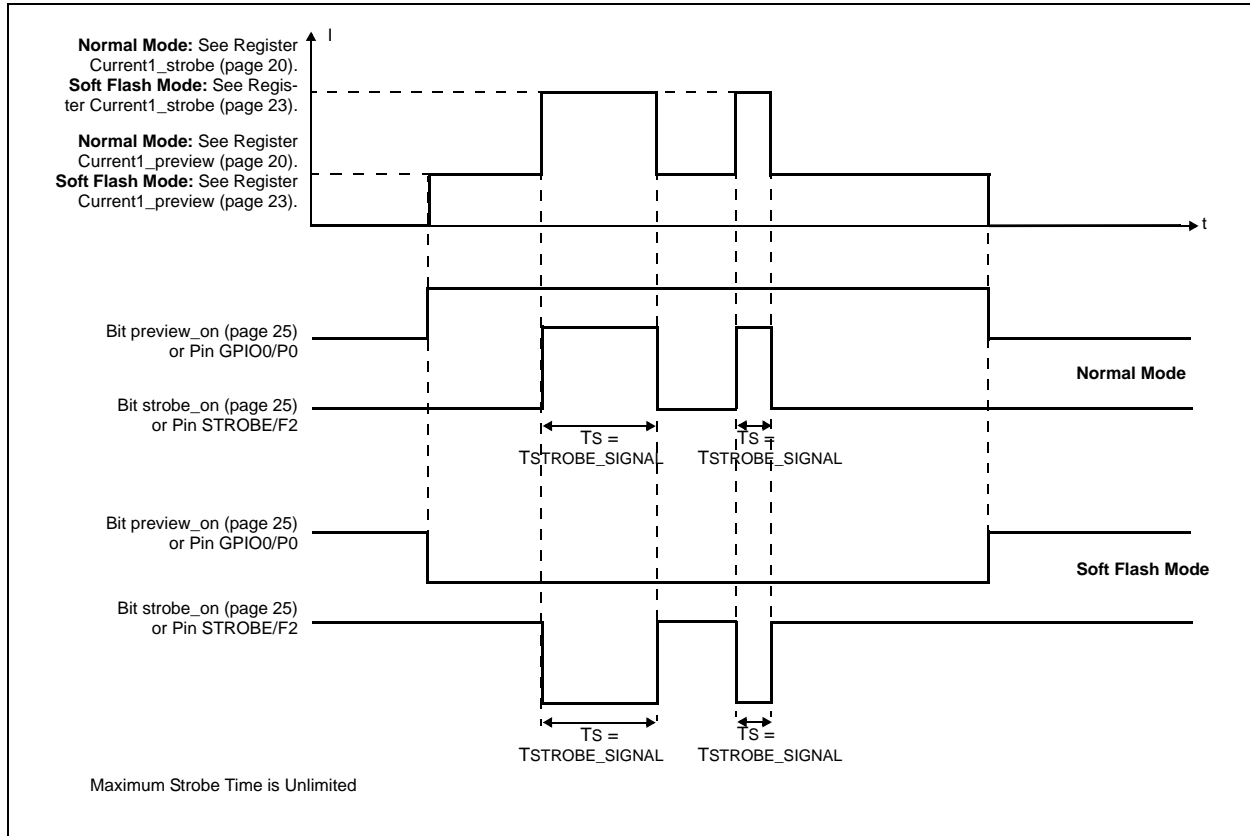

Figure 17. Preview and Strobe Timing – Mode 3



www.DataSheet4U.com

11.4 Control of CURR₂, CURR₃, CURR₄ in Normal Mode and Soft Flash Mode

CURR₂, CURR₃, and CURR₄ are independent current sinks. The current value is determined by registers **Current2** (page 21), **Current3** (page 21), and **Current4** (page 22).

Any value other than zero will start the current sink. To stop the current, the register value must be set to zero.

Note: Unused current sinks should be left open and any associated register values must be set to 0mA.

Table 30. Current Sink_{2,3,4} Undervoltage Indication Registers

Addr: 0F		Curr_voltage_control		
		This register indicates if the voltage at any current sink has dropped below a predefined value. If the charge pump is operating in automatic-mode (default), the contents of this register can be disregarded. The voltages at current sinks 1x are used for automatic mode selection of the charge pump. The voltages at current sinks 2, 3, and 4 can be optionally used for automatic mode selection of the charge pump (see register Curr234_ctrl (page 29)).		
Bit	Bit Name	Default	Access	Description
0	curr11_low_voltage	N/A	R	See curr11_low_voltage (page 26).
1	curr12_low_voltage	N/A	R	See curr12_low_voltage (page 26).
2	Curr13_low_voltage	N/A	R	See curr12_low_voltage (page 26).
3	Curr2_low_voltage	N/A	R	0 = Normal operation. 1 = Undervoltage occurred.
4	Curr3_low_voltage	N/A	R	0 = Normal operation. 1 = Undervoltage occurred.
5	Curr4_low_voltage	N/A	R	0 = Normal operation. 1 = Undervoltage occurred.
7:6	cp_status	N/A	R	See cp_status (page 30).
Addr: 09		Curr234_ctrl		
		This register defines whether the load of the current sink is connected to pin VBAT or to pin CP_OUT. If the load of the current sink is connected to CP_OUT, that current sink will contribute to the charge pump mode-selection algorithm.		
Bit	Bit Name	Default	Access	Description
0	Curr2_onCP	0	R/W	0 = The output of the current sink will not be used for automatic mode selection of the charge pump. 1 = The output of the current sink is used for automatic mode selection of the charge pump.
1	Curr3_onCP	0	R/W	0 = The output of the current sink will not be used for automatic mode selection of the charge pump. 1 = The output of the current sink is used for automatic mode selection of the charge pump.
2	Curr4_onCP	0	R/W	0 = The output of the current sink will not be used for automatic mode selection of the charge pump. 1 = The output of the current sink is used for automatic mode selection of the charge pump.
3	Curr234_gpio0_ctrl	0	R/W	0 = Curr2, Curr3, and Curr4 are switched on/off directly by registers Current2 (page 23), Current3 (page 23), and Current4 (page 23). 1 = Curr2, Curr3, Curr4 are switched on/off by pin GPIO0/P0 (set bit preview_ctrl (page 25) = 1 and bit Curr234_strobe_ctrl = 0).
6:4	N/A			
7	Curr234_strobe_ctrl	0	R/W	0 = Curr2, Curr3, and Curr4 are switched on/off directly by registers Current2 (page 23), Current3 (page 23), and Current4 (page 23). 1 = Curr2, Curr3, Curr4 are controlled by Strobe mode (enable at least one of curr11_on (page 24), curr12_on (page 24), or curr13_on (page 24)).

11.5 Charge Pump Control Registers

Addr: 00		Powerdown_control		
This register switches the charge pump and current sinks_1x on and off.				
Bit	Bit Name	Default	Access	Description
0	cp_led_on	0	R/W	Charge pump enable/disable. 0 = Switches the charge pump off. 1 = Switches the charge pump on.
1	curr11_on			See curr11_on (page 24).
2	curr12_on			See curr12_on (page 24).
3	curr13_on			See curr13_on (page 24).
7:4	N/A			

Addr: 0D		CP_control		
This register sets the charge pump mode and reads the current charge pump mode.				
Bit	Bit Name	Default	Access	Description
0	cp_clk	0	R/W	Charge pump clock frequency selection. 0 = 1MHz 1 = 500 kHz
1	cp_man	0	R/W	Charge pump mode control. 0 = Automatic mode. 1 = Manual mode.
3:2	cp_mode	00b	R/W	Charge pump mode selection. 01 = N/A 01 = Charge pump mode 1:1. 10 = Charge pump mode 1:1.5. 11 = Charge pump mode 1:2.
4	cp_mode2	0	R/W	Used for test purposes only.
5:7	N/A			

Addr: 0F		Curr_voltage_control		
This register indicates if the voltage at any current sink has dropped below a predefined value. If the charge pump is operating in automatic-mode (default), the contents of this register can be disregarded. The voltages at current sinks 1x are used for automatic mode selection of the charge pump. The voltages at current sinks 2, 3, and 4 can be optionally used for automatic mode selection of the charge pump (see register Curr234_ctrl (page 29)).				
Bit	Bit Name	Default	Access	Description
0	curr11_low_voltage	N/A	R	See curr11_low_voltage (page 26).
1	curr12_low_voltage	N/A	R	See curr12_low_voltage (page 26).
2	curr13_low_voltage	N/A	R	See curr13_low_voltage (page 26).
3	curr2_low_voltage	N/A	R	See curr2_low_voltage (page 29).
4	curr3_low_voltage	N/A	R	See curr3_low_voltage (page 29).
5	curr4_low_voltage	N/A	R	See curr4_low_voltage (page 29).
7:6	cp_status	N/A	R	01 = Charge pump mode 1:1. 10 = Charge pump mode 1:1.5. 11 = Charge pump mode 1:2.

11.6 General Purpose Inputs/Outputs

The general purpose input/output pins (GPIO0/P0, STROBE/F2) are highly configurable and can be used for the following functionality:

- Digital Schmidt-Trigger Input
- Digital Output with 4mA Driving Capability at 2.8V Supply (VDD_GPIO)
- Tristate Output
- Current Selection for CURR_{1x}

The default mode for pins GPIO0/P0 and STROBE/F2 is input (pull-down for normal mode and pull-up for soft flash or hard flash modes).

Note: Each general purpose pin is independent of the other general purpose pin.

Table 31. GPIO Registers

Addr: 0A		GPIO_control		
This register controls pins GPIO0/P0 and STROBE/F2.				
Bit	Bit Name	Default	Access	Description
1:0	gpio0_mode	00b	R/W	Defines the direction for pin GPIO0/P0. 00 = Input only. 01 = Output (push and pull). 10 = Output (open drain, only NMOS is active). 11 = Output (open drain, only PMOS is active).
3:2	gpio0_pulls	01b Normal Mode 10b Soft Flash Mode	R/W	Adds pullup/pulldown functionality to pin GPIO0/P0. 00 = None 01 = Pulldown 10 = Pullup 11 = Analog input (for test purposes only).
5:4	strobe_mode	00b	R/W	Defines the direction for pin STROBE/F2. 00 = Input only. 01 = Output (push and pull). 10 = Output (open drain, only NMOS is active). 11 = Output (open drain, only PMOS is active).
7:6	strobe_pulls	01b Normal Mode 10b Soft Flash Mode	R/W	Adds pullup/pulldown functionality to pin STROBE/F2. 00 = None 01 = Pulldown 10 = Pullup 11 = Analog input (for test purposes only)
Addr: 0B		GPIO_output		
This register selects internal signals to be switched to pins GPIO0/P0 and STROBE/F2 (if selected as output).				
Bit	Bit Name	Default	Access	Description
0	gpio0_out	0	R/W	In normal mode, if pin GPIO0/P0 is set to output, this bit is transferred to that output.
1	strobe_out	0	R/W	In normal mode, if pin STROBE/F2 is set to output, this bit is transferred to that output.
2:7	N/A			
Addr: 0C		GPIO_input		
This register reads the signals at pins GPIO0/P0 and STROBE/F2 (if selected as input).				
Bit	Bit Name	Default	Access	Description
0	gpio0_in	N/A	R	
1	strobe_in	N/A	R	

11.7 Power-On Reset

The internal reset is controlled by two inputs:

- VBAT1 Supply
- VDD_GPIO

If either of these voltages is lower than their limit, an internal reset is forced.

The reset levels control the state of all registers. As long as VBAT and VDD_GPIO are below their reset thresholds, the register contents are set to default.

Access by serial interface is possible once the reset thresholds are exceeded.

Table 32. Reset Control

Reset Control	Register State (All Registers)
$V_{BAT} < V_{POR_VBAT}$ and $V_{VDD_GPIO} < V_{GPIO_VDD_TH}$	Undefined
$V_{BAT} < V_{POR_VBAT}$ and $V_{VDD_GPIO} > V_{GPIO_VDD_TH}$	Undefined
$V_{BAT} > V_{POR_VBAT}$ and $V_{VDD_GPIO} < V_{GPIO_VDD_TH}$	Default
$V_{BAT} > V_{POR_VBAT}$ and $V_{VDD_GPIO} > V_{GPIO_VDD_TH}$	Default
	Access by serial interface possible.

Note: $V_{VDD_GPIO_TH}$ – Use rising or falling threshold levels, depending on the slope of VDD_GPIO (power up/power down).

11.8 Temperature Supervision

An integrated temperature sensor provides over-temperature protection for the AS3682. This sensor generates a flag if the device temperature reaches the over-temperature threshold (T_{140} page 8). The threshold has a hysteresis (T_{140} page 8) to prevent oscillation effects.

If the device temperature exceeds the T_{140} threshold, the current sources are switched off, and bit **ov_temp** in register **Overtemp_control** (page 32) is set to 1.

After decreasing the temperature by T_{HYST} , the current sources resume operation.

The **ov_temp** flag will only be reset (by the circuit when the temperature has reached operating condition again) after the software has written a 1 and then a 0 to bit **rst_ov_temp** (page 32).

Bit **ov_temp_on** activates temperature supervision.

Table 33. Overtemperature Bit Definitions

Addr: 0E		Overtemp_control		
This register reads and resets the overtemperature flag.				
Bit	Bit Name	Default	Access	Description
0	ov_temp_on	1	R/W	Activates/deactivates device temperature supervision. 0 = Temperature supervision is disabled. No current source will be switched off if the device temperature exceeds the over-temperature rising threshold (T_{140}). 1 = Temperature supervision is enabled.
1	ov_temp	NA	R	1 = Indicates that the over-temperature rising threshold (T_{140}) has been reached. To clear this flag, it is mandatory to use bit rst_ov_temp . Bit ov_temp is only active if temperature supervision is activated.
2	rst_ov_temp	NA	R/W	The ov_temp flag is cleared by first setting this bit to 1, and then setting this bit to 0. Bit rst_ov_temp is only active if temperature supervision is activated.
7:3	N/A			

11.9 Serial Interface

The AS3682 is controlled by serial interface pins DATA/P1 and CLK/P2.

11.9.1 Features

- Fast Mode Capability (Maximum Clock Frequency is 400 kHz)
- 7-Bit Addressing Mode
- 4 x 8-Bit Read/Write Data Registers (Word Address 0x0 to 0x3)
- Write Formats
 - Single-Byte Write
 - Page-Write
- Read Formats
 - Current-Address Read
 - Random-Read
 - Sequential-Read
- Asynchronous Reset Input (Active 0)
- No Internal System Clock
- DATA/P1 Input Delay and CLK/P2 Spike Filtering by Integrated RC Components

11.9.2 Device Address Selection

The serial interface address of the AS3682 can be selected between two fixed settings. The address is selected by connecting pin ADR to either GND or to V2_5 as shown in Table 34.

Table 34. AS3682 Device Address Selection

ADR Connected To	Serial Interface Address
GND	40h
V2_5 (Max Voltage = 2.5V)	41h

11.9.3 Data Transfer Formats

Definitions used in the serial data transfer format diagrams (Figures 19 to 23) are listed in Table 35.

Table 35. Serial Data Transfer Byte Definitions

Symbol	Definition
S	Start Condition after Stop
Sr	Repeated Start
DA	Device Address
WA	Word Address
A	Acknowledge
N	Not Acknowledge
P	Stop Condition
White Field	Slave as Receiver
Grey Field	Slave as Transmitter
WA++	Increment Word Address Internally

Figure 18. Complete Data Transfer

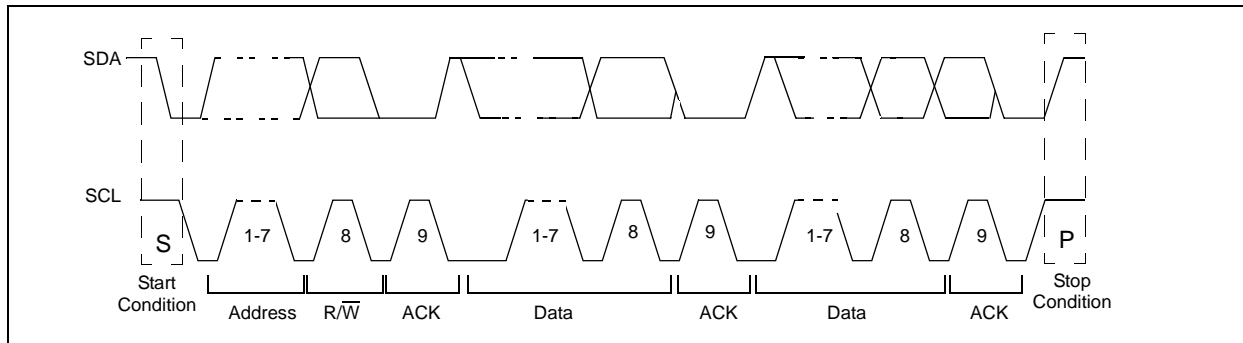

Figure 19. Byte Write

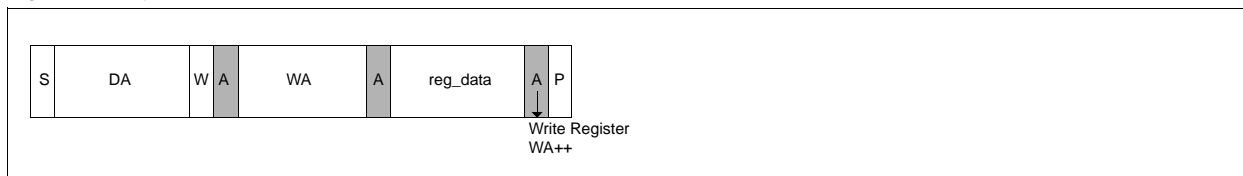
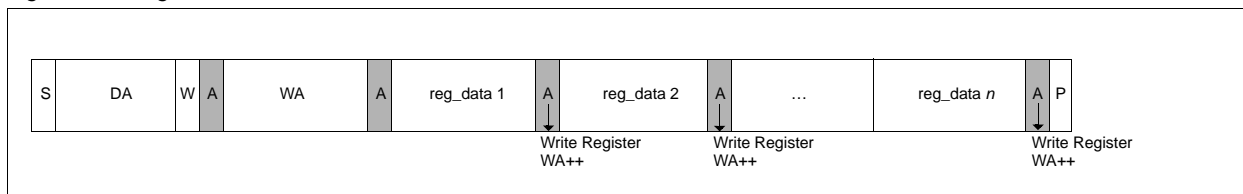

Figure 20. Page Write



Byte Write and Page Write are used to write data to the slave.

The transmission begins with the START condition, which is generated by the master when the bus is in IDLE state (the bus is free). The device-write address is followed by the word address. After the word address any number of data bytes can be send to the slave. The word address is incremented internally, in order to write subsequent data bytes on subsequent address locations.

For reading data from the slave device, the master has to change the transfer direction. This can be done either with a repeated START condition followed by the device-read address, or simply with a new transmission START followed by the device-read address, when the bus is in IDLE state. The device-read address is always followed by the 1st register byte transmitted from the slave. In Read Mode any number of subsequent register bytes can be read from the slave. The word address is incremented internally.

The following diagrams show the various read formats available.

Figure 21. Random Read

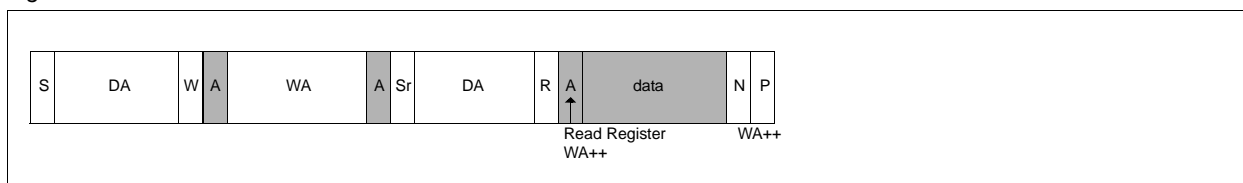

Random Read and Sequential Read are combined formats. The repeated START condition is used to change the direction after the data transfer from the master.

The word address transfer is initiated with a START condition issued by the master while the bus is idle. The START condition is followed by the device-write address and the word address.

In order to change the data direction a repeated START condition is issued on the 1st SCL pulse after the ACKNOWLEDGE bit of the word address transfer. After the reception of the device read address, the slave becomes the transmitter. In this state the slave transmits register data located by the previous received word address vector. The master responds to the data byte with a NOT ACKNOWLEDGE, and issues a STOP condition on the bus.

Figure 22. Sequential Read

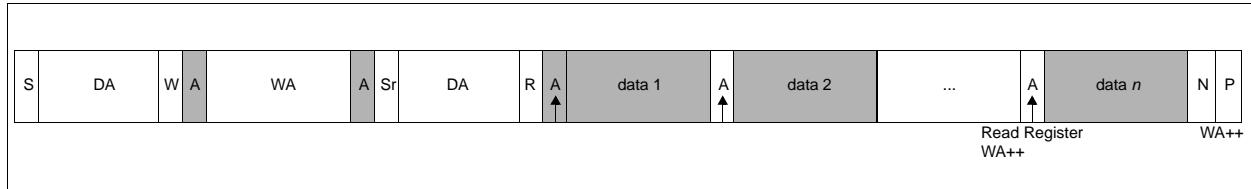

Sequential Read is the extended form of Random Read, as multiple register-data bytes are subsequently transferred. In contrast to the Random Read, in a Sequential Read the transferred register-data bytes are responded to by an ACKNOWLEDGE from the master. The number of data bytes transferred in one sequence is unlimited (consider the behavior of the word-address counter). To terminate the transmission the master has to send a not-acknowledge following the last data byte and subsequently generate the STOP condition.

Figure 23. Current Address Read

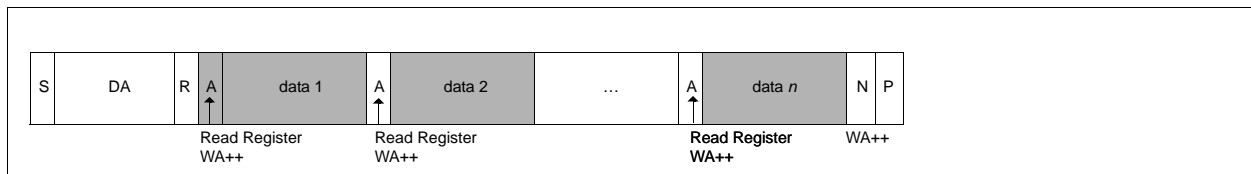

To keep the access time as small as possible, this format allows a read access without the word address transfer in advance to the data transfer. The bus is idle and the master issues a START condition followed by the Device Read address. Analogous to Random Read, a single byte transfer is terminated with a not-acknowledge after the first register byte. Analogous to Sequential Read an unlimited number of data bytes can be transferred, where the data bytes must be responded to with an ACKNOWLEDGE from the master. For termination of the transmission the master sends a NOT ACKNOWLEDGE following the last data byte and a subsequent STOP condition.

11.9.4 Fixed ID Register

Reading register 15h always returns CDh and can be used to verify the correct operation of the serial interface.

Table 36. Fixed ID Register

Addr: 15		Fixed_ID		
This register holds the device ID value.				
Bit	Bit Name	Default	Access	Description
7:0	Device_ID	11001101	R	This is the device ID.

11.10 Register Map

The AS3682 control register addresses, default values, and pages where they are described are listed in Table 37 (Normal Mode) and Table 38 (Soft Flash Mode).

Table 37. Register Summary – Normal Mode

Register Name	Address	Default	B7	B6	B5	B4	B3	B2	B1	B0	Page	
Powerdown_control	Addr: 00	00h	N/A				curr13_on	curr12_on	curr11_on	cp_led_on		24, 30
Current1_preview	Addr: 01	00h	current1_preview				N/A			curr_hp		20
Current1_strobe	Addr: 02	00h	current1_strobe				N/A			curr_hs		20
Current1_control	Addr: 03	01h	xstrobe_ctrl	strobe_on	preview_ctrl	preview_on	N/A		Strobe_mode			25
Strobe_mode1	Addr: 04	07h	N/A				Strobe_mode					25
Strobe_mode2	Addr: 05	07h	N/A				Mode2					26
Current2	Addr: 06	00h	N/A				Current2					21
Current3	Addr: 07	00h	N/A				Current3					21
Current4	Addr: 08	00h	N/A				Current4					22
Curr234_ctrl	Addr: 09	00h	Curr234_strobe_ctrl	N/A			Curr234_gpio0_ctrl	Curr4_onCP	Curr3_onCP	Curr2_onCP		29
GPIO_control	Addr: 0A	44h	strobe_pulls		strobe_mode		gpio0_pulls		gpio0_mode			31
GPIO_output	Addr: 0B	00h	N/A						strobe_out	gpio0_out		31
GPIO_input	Addr: 0C	N/A	N/A						strobe_in	gpio0_in		31
CP_control	Addr: 0D	00h	N/A			cp_mode2	cp_mode		cp_man	cp_clk		30
Overtemp_control	Addr: 0E	01h	N/A				rst_ov_temp	ov_temp	ov_temp_on			32
Curr_voltage_control	Addr: 0F	N/A	cp_status		Curr4_low_voltage	Curr3_low_voltage	Curr2_low_voltage	curr13_low_voltage	curr12_low_voltage	curr11_low_voltage		30
Curr_voltage_control	Addr: 0F	N/A	cp_status		Curr4_low_voltage	Curr3_low_voltage	Curr2_low_voltage	curr13_low_voltage	curr12_low_voltage	curr11_low_voltage		26
Curr_voltage_control	Addr: 0F	N/A	cp_status		Curr4_low_voltage	Curr3_low_voltage	Curr2_low_voltage	curr13_low_voltage	curr12_low_voltage	curr11_low_voltage		29
Fixed_ID	Addr: 15	CDh	1	1	0	0	1	1	0	1		35

Table 38. Register Summary – Soft Flash Mode

Register Name	Address	Default	B7	B6	B5	B4	B3	B2	B1	B0	Page	
Powerdown_control	Addr: 00	00h	N/A				curr13_on	curr12_on	curr11_on	cp_led_on		24, 30
Current1_preview	Addr: 01	00h	current1_preview									23
Current1_strobe	Addr: 02	00h	current1_strobe									23
Current1_control	Addr: 03	01h	xstrobe_ctrl	strobe_on	preview_ctrl	preview_on	N/A		Strobe_mode			25
Strobe_mode1	Addr: 04	07h	N/A				Strobe_mode					25
Strobe_mode2	Addr: 05	07h	N/A				Mode2					26
Current2	Addr: 06	00h	Current2									23
Current3	Addr: 07	00h	Current3									23
Current4	Addr: 08	00h	Current4									23
Curr234_ctrl	Addr: 09	00h	Curr234_strobe_ctrl	N/A			Curr234_gpio0_ctrl	Curr4_onCP	Curr3_onCP	Curr2_onCP		29
GPIO_control	Addr: 0A	88h	strobe_pulls		strobe_mode		gpio0_pulls		gpio0_mode			31
GPIO_output	Addr: 0B	00h	N/A						strobe_out	gpio0_out		31
GPIO_input	Addr: 0C	N/A	N/A						strobe_in	gpio0_in		31
CP_control	Addr: 0D	00h	N/A			cp_mode2	cp_mode		cp_man	cp_clk		30
Overtemp_control	Addr: 0E	01h	N/A				rst_ov_temp	ov_temp	ov_temp_on			32
Curr_voltage_control	Addr: 0F	N/A	cp_status		Curr4_low_voltage	Curr3_low_voltage	Curr2_low_voltage	curr13_low_voltage	curr12_low_voltage	curr11_low_voltage		30
Curr_voltage_control	Addr: 0F	N/A	cp_status		Curr4_low_voltage	Curr3_low_voltage	Curr2_low_voltage	curr13_low_voltage	curr12_low_voltage	curr11_low_voltage		26
Curr_voltage_control	Addr: 0F	N/A	cp_status		Curr4_low_voltage	Curr3_low_voltage	Curr2_low_voltage	curr13_low_voltage	curr12_low_voltage	curr11_low_voltage		29
Fixed_ID	Addr: 15	CDh	1	1	0	0	1	1	0	1		35

12 External Components

12.1 Capacitor and Resistor Selection

Use low-ESR ceramic capacitors with X7R or X5R dielectric – these capacitors allow good filtering and have a wide temperature range. The connections of all external capacitors should be kept as short as possible.

All resistors should have a tolerance of $\pm 1\%$.

12.2 Usage of PCB Wire Inductance

The inductance between the battery and pins VBAT1 and VBAT2 can be used as a filter to reduce disturbance on the battery. Instead of using one capacitor (C1) it is recommended to split C1 into C11 and C12 with the capacitance equal:

$$C_{11} = C_{12} = 1/2 \times C_1 \quad (EQ 1)$$

It is recommended to apply a minimum of 20nH (maximum 200nH) with low impedance. This inductance can be realized on the PCB without any discrete coil. Assuming that 1mm signal line corresponds to approximately 1nH (valid if the length (L) is significantly bigger than the width (W) of the line ($L/W < 10$)). Thus a line length of:

$$20\text{mm} < L < 200\text{mm} \quad (EQ 2)$$

is recommended. The shape of the line is not important.

Figure 24. PCB Wire Inductance Example 1



Figure 25. PCB Wire Inductance Example 2

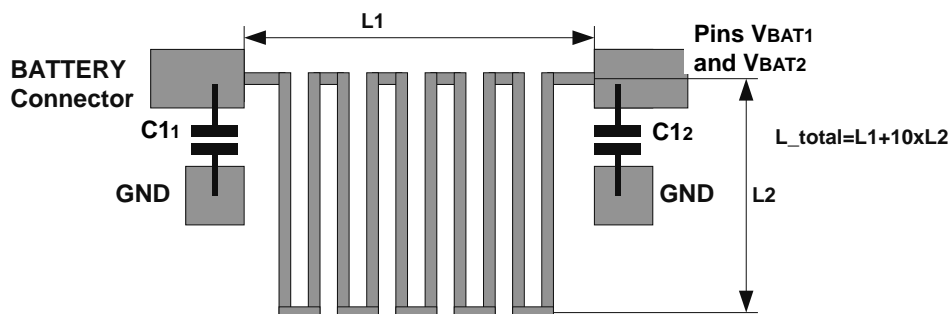

12.3 External Component Specifications

Table 39. External Components List

Part Number	Value			Tol (Min)	Rating (Max)	Notes	Package (Min)
	Min	Typ	Max				
C11		2.2 μ F		$\pm 20\%$	6.3V	Ceramic, X5R	0603
C3	1 μ F		4.7 μ F	$\pm 20\%$	6.3V	Ceramic, X5R	0603
C4		1 μ F		$\pm 20\%$	6.3V	Ceramic, X5R	0603
C5		1 μ F		$\pm 20\%$	6.3V	Ceramic, X5R	0603
C6		2.2 μ F		$\pm 20\%$	6.3V	Ceramic, X5R	0603
R1		240k Ω		$\pm 1\%$		Bias Resistor	0201

Notes:

1. See Usage of PCB Wire Inductance on page 37.

13 Pinout and Packaging

Table 40. Pin Type Definitions

Type	Description
DI	Digital Input
DI3	3.3V Digital Input
DIO3	3.3V Digital Input/Output
AIO	Analog Pad
AI	Analog Input
AO	Analog Output
S	Supply Pad
GND	Ground Pad

13.1 Hard Flash Modes Pin Descriptions

Table 41. Pin List QFN24 – Hard Flash Modes

Pin	Name	Type (See Table 40)	Description
1	ADR	DI	Test input.
2	VBAT1	AIO	Charge pump supply pad; always connect to VBAT.
3	C1_P	AIO	Charge pump flying capacitor; connect to a ceramic capacitor of 2.2 μ F (\pm 20%).
4	CP_OUT	AIO	Charge pump output voltage; connect to a ceramic capacitor of 1 μ F (\pm 20%) or 2.2 μ F (+100%/-50%).
5	C2_P	AIO	Charge pump flying capacitor; connect to a ceramic capacitor of 2.2 μ F (\pm 20%).
6	VBAT2	S	Charge pump supply pad; always connect to VBAT.
7	C2_N	AIO	Charge pump flying capacitor; connect to a ceramic capacitor of 1 μ F (\pm 20%).
8	CLK/P2	DI3	MSB of Preview Control; internal pullup, active low.
9	DATA/P1	DIO3	LSB+1/MSB of Preview Control; internal pullup, active low.
10	GPIO0/P0	DIO3	LSB of Preview Control; internal pullup, active low.
11	STROBE/F2	DIO3	MSB of Flash Control; internal pullup, active low.
12	VDD_GPIO	S	GPIO and serial interface supply pad.
13	CURR11	AI	Analog current sink input.
14	CURR12	AI	Analog current sink input.
15	CURR13	AI	Analog current sink input.
16	SFL/F1	DI3	LSB+1 of Flash Control; internal pullup, active low.
17	T1/F0	DI3	LSB of Flash Control; internal pullup, active low.
18	HFL	DI	Hard Flash mode selection pin; connect to VBAT.
19	CURR2	AI	Analog current sink input.
20	CURR3	AI	Analog current sink input.
21	CURR4	AI	Analog current sink input.
22	V2_5	AO	Low-power LDO output voltage; always connect to a ceramic capacitor of 1 μ F (\pm 20%) or 2.2 μ F (+100%/-50%). Caution: Do not load this pin during start-up.
23	RBIAS	AIO	External resistor; always connect to a resistor of 240k Ω (\pm 1%) to ground. Caution: Do not load this pin.
24	C1_N	AIO	Charge pump flying capacitor; connect to a ceramic capacitor of 1 μ F (\pm 20%).
25	VSS	GND	Exposed pad.

13.2 Normal Mode and Soft Flash Mode Pin Descriptions

Table 42. Pin List QFN24 – Normal Mode and Soft Flash Mode

Pin	Name	Type (See Table 40)	Description
1	ADR	DI	Input pin to select serial interface address. Connect to V _{2_5} or V _{SS} .
2	VBAT1	S	Charge pump supply pad; always connect to V _{BAT} .
3	C1_P	AIO	Charge pump flying capacitor; connect to a ceramic capacitor of 2.2μF (±20%).
4	CP_OUT	AIO	Charge pump output voltage; connect to a ceramic capacitor of 1μF (±20%) or 2.2μF (+100%/-50%).
5	C2_P	AIO	Charge pump flying capacitor; connect to a ceramic capacitor of 2.2μF (±20%).
6	VBAT2	S	Charge pump supply pad; always connect to V _{BAT} .
7	C2_N	AIO	Charge pump flying capacitor; connect to a ceramic capacitor of 1μF (±20%).
8	CLK/P2	DI3	Serial interface clock input.
9	DATA/P1	DIO3	Serial interface data I/O.
10	GPIO0/P0	DIO3	General purpose I/O; active high in Normal Mode, active low in Soft Flash Mode.
11	STROBE/F2	DIO3	General purpose I/O; active high in Normal Mode, active low in Soft Flash Mode.
12	VDD_GPIO	S	GPIO and serial interface supply pad.
13	CURR11	AI	Analog current sink input (intended for LED flash).
14	CURR12	AI	Analog current sink input (intended for LED flash).
15	CURR13	AI	Analog current sink input (intended for LED flash).
16	SFL/F1	DI3	Soft Flash mode selection pin.
17	T1/F0	DI3	Test input.
18	HFL	DI	Hard Flash mode selection pin; active high.
19	CURR2	AI	Analog current sink input.
20	CURR3	AI	Analog current sink input.
21	CURR4	AI	Analog current sink input.
22	V _{2_5}	AO	Low-power LDO output voltage; always connect to a ceramic capacitor of 1μF (±20%) or 2.2μF (+100%/-50%). Caution: Do not load this pin during start-up.
23	RBIAS	AIO	External resistor; always connect to a resistor of 240kΩ (±1%) to ground. Caution: Do not load this pin.
24	C1_N	AIO	Charge pump flying capacitor; connect to a ceramic capacitor of 1μF (±20%).
25	V _{SS}	GND	Exposed pad.

13.3 Package Drawings and Markings

Figure 26. QFN 24 – 4x4mm with Exposed Paddle

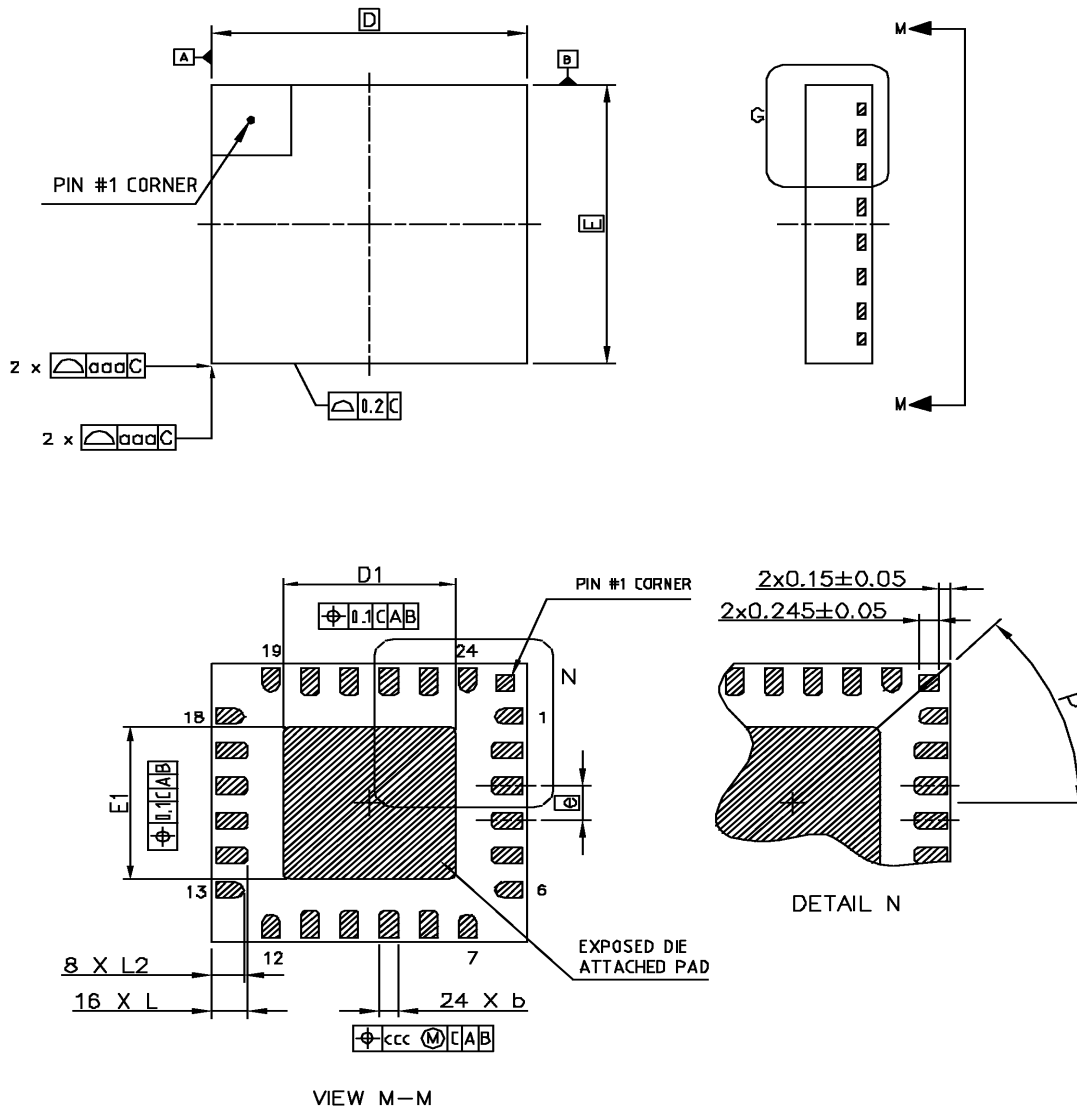

Marking:

- Line 1: austriamicrosystems Logo
 Line 2: AYWWIZZ
 A = Pb-Free Identifier
 Y = Year
 WW = Week
 I = Plant Identifier
 ZZ = Letters of Free Choice
 Line 3: AS3682A
 Line 4: <Empty> = Normal Mode, Soft Flash Mode, and Hard Flash Mode 1
 HFL2 = Hard Flash Mode 2

Figure 27. QFN 24 – Detail Dimensions

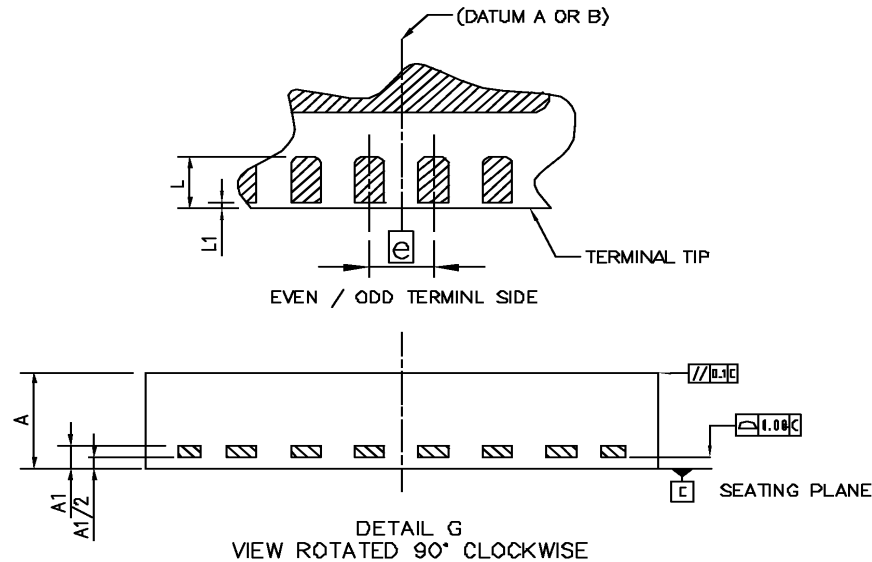

DIM	MIN	NOM	MAX	NOTES		
A	0.75	0.85	0.95	1.0 DIMENSIONING & TOLERANCEING CONFIRM TO ASME Y14.5M-1994. 2.0 ALL DIMENSIONS ARE IN MILLIMETERS. ANGLES ARE IN DEGREES. 3.0 DIMENSION b APPLIES TO METALLIZED TERMINAL AND IS MEASURED BETWEEN 0.25mm AND 0.30mm FROM TERMINAL TIP. DIMENSION L1 REPRESENTS TERMINAL FULL BACK FROM PACKAGE EDGE UP TO 0.1mm IS ACCEPTABLE. 4.0 COPLANARITY APPLIES TO THE EXPOSED HEAT SLUG AS WELL AS THE TERMINAL. 5.0 RADIUS ON TERMINAL IS OPTIONAL.		
A1	0.19		0.21			
b	0.18	0.23	0.28			
D		4.0 BSC				
E		4.0 BSC				
e		0.50 BSC				
D1	2.10	2.20	2.30			
E1	2.10	2.20	2.30			
L	0.40	0.50	0.60			
L1			0.10			
L2	0.30	0.40	0.50			
P		45 REF				
aaa		0.10		UNIT	DIMENSION AND TOLERANCE	REFERENCE DOCUMENT
ccc		0.10		Millimeter(mm)	ASME Y14.5M	JEDEC MO-220

14 Ordering Information

Device ID	Part Number	Package Type	Delivery Form*	Mode	Description
AS3682-PDM	AS3682-EA1	QFN 24	Tape and Reel	Normal Mode, Soft Flash Mode, Hard Flash Mode 1	4x4x0.85mm, Pitch = 0.5mm
	AS3682-EB1		Tube		
	AS3682-EA2		Tape and Reel	Hard Flash Mode 2	
	AS3682-EB2		Tube		

Where:

P = Package Type:

E = QFN 4x4x0.85mm

D = Delivery Form:

A = Tape and Reel

B = Tube

M = Mode

1 = Normal Mode, Soft Flash Mode, and Hard Flash Mode 1

2 = Hard Flash Mode 2

* Dry-pack sensitivity level = 3 in accordance with *IPC/JEDEC J-STD-033A*.

Copyrights

Copyright © 1997-2006, austriamicrosystems AG, Schloss Premstaetten, 8141 Unterpremstaetten, Austria-Europe. Trademarks Registered ®. All rights reserved. The material herein may not be reproduced, adapted, merged, translated, stored, or used without the prior written consent of the copyright owner.

All products and companies mentioned are trademarks or registered trademarks of their respective companies.

Disclaimer

Devices sold by austriamicrosystems AG are covered by the warranty and patent indemnification provisions appearing in its Term of Sale. austriamicrosystems AG makes no warranty, express, statutory, implied, or by description regarding the information set forth herein or regarding the freedom of the described devices from patent infringement. austriamicrosystems AG reserves the right to change specifications and prices at any time and without notice. Therefore, prior to designing this product into a system, it is necessary to check with austriamicrosystems AG for current information. This product is intended for use in normal commercial applications. Applications requiring extended temperature range, unusual environmental requirements, or high reliability applications, such as military, medical life-support or life-sustaining equipment are specifically not recommended without additional processing by austriamicrosystems AG for each application. For shipments of less than 100 parts the manufacturing flow might show deviations from the standard production flow, such as test flow or test location.

The information furnished here by austriamicrosystems AG is believed to be correct and accurate. However, austriamicrosystems AG shall not be liable to recipient or any third party for any damages, including but not limited to personal injury, property damage, loss of profits, loss of use, interruption of business or indirect, special, incidental or consequential damages, of any kind, in connection with or arising out of the furnishing, performance or use of the technical data herein. No obligation or liability to recipient or any third party shall arise or flow out of austriamicrosystems AG rendering of technical or other services.

www.DataSheet4U.com

Contact Information

Headquarters

austriamicrosystems AG
A-8141 Schloss Premstaetten, Austria

Tel: +43 (0) 3136 500 0
Fax: +43 (0) 3136 525 01

For Sales Offices, Distributors and Representatives, please visit:

<http://www.austriamicrosystems.com>

austriamicrosystems – a leap ahead