

AS3691

4 Precision 400mA Current Sources for RGB and Single Color Leds

1 General Description

The AS3691 (AS3691A and AS3691B) features four high precision current sources for lighting of up to four LED strings (RGB or single color leds). Each of the four currents sources can be controlled independently by PWM inputs. The full scale current value is set by external resistors.

2 Key Features

- 4 x up to 0.4A constant current outputs
- Programmable with external resistors
- 4 independent PWM inputs
- Absolute current accuracy +/-0.5%
- Automatic Supply Regulation¹⁾ to reduce power dissipation¹⁾

¹⁾ Patent Pending

- Very wide output voltage current source voltage compliance
 - Down to 0.41V
 - Up to 15V²⁾
- Integrated overtemperature protection
- Separate sense pads (Rfb1-Rfb4) for easy and precise PCB Layout
- Package
 - DIE
 - QFN24 4x4mm
 - eP-TSSOP

²⁾ 15V is sufficient for most applications as the AS3691 does not switch off the LED current completely

3 Applications

- General Lighting
- Backlighting
- RGB Backlighting for LCD TV/Monitors with White Color Balancing

4 Application Diagrams

Figure 1 – Application Diagram of AS3691 for Single Color Lighting

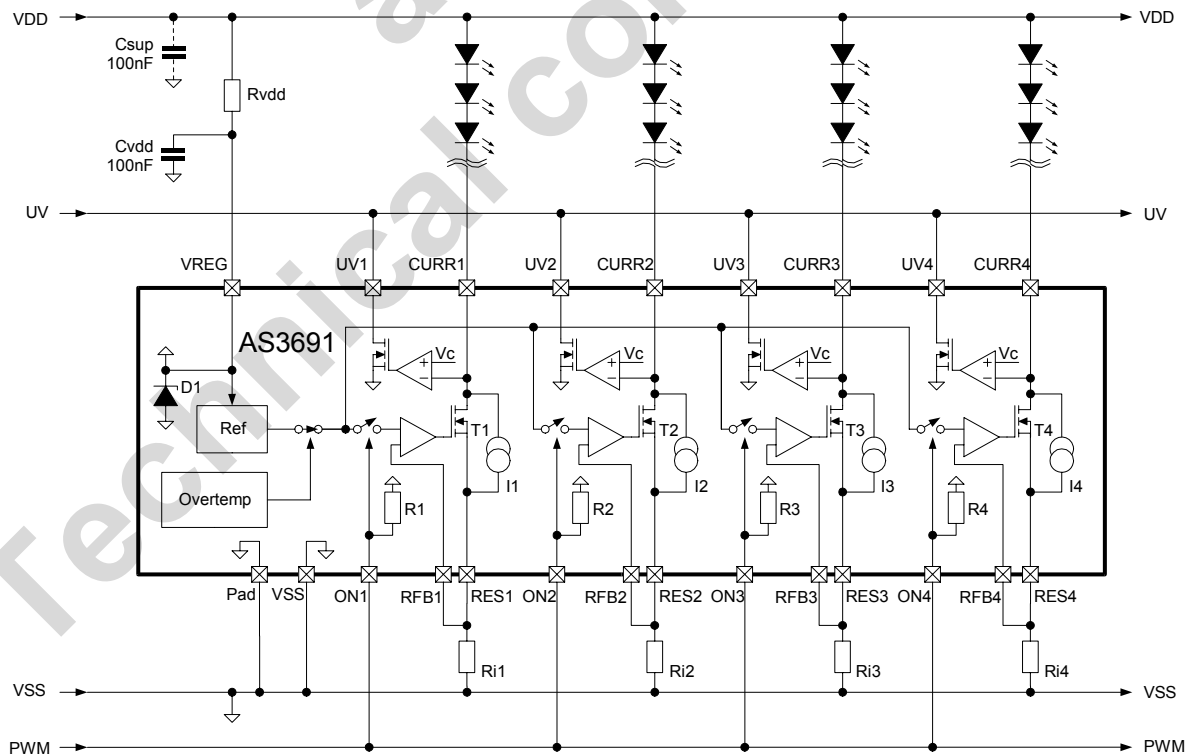

Figure 2 – Application Diagram of AS3691 for RGB Lighting

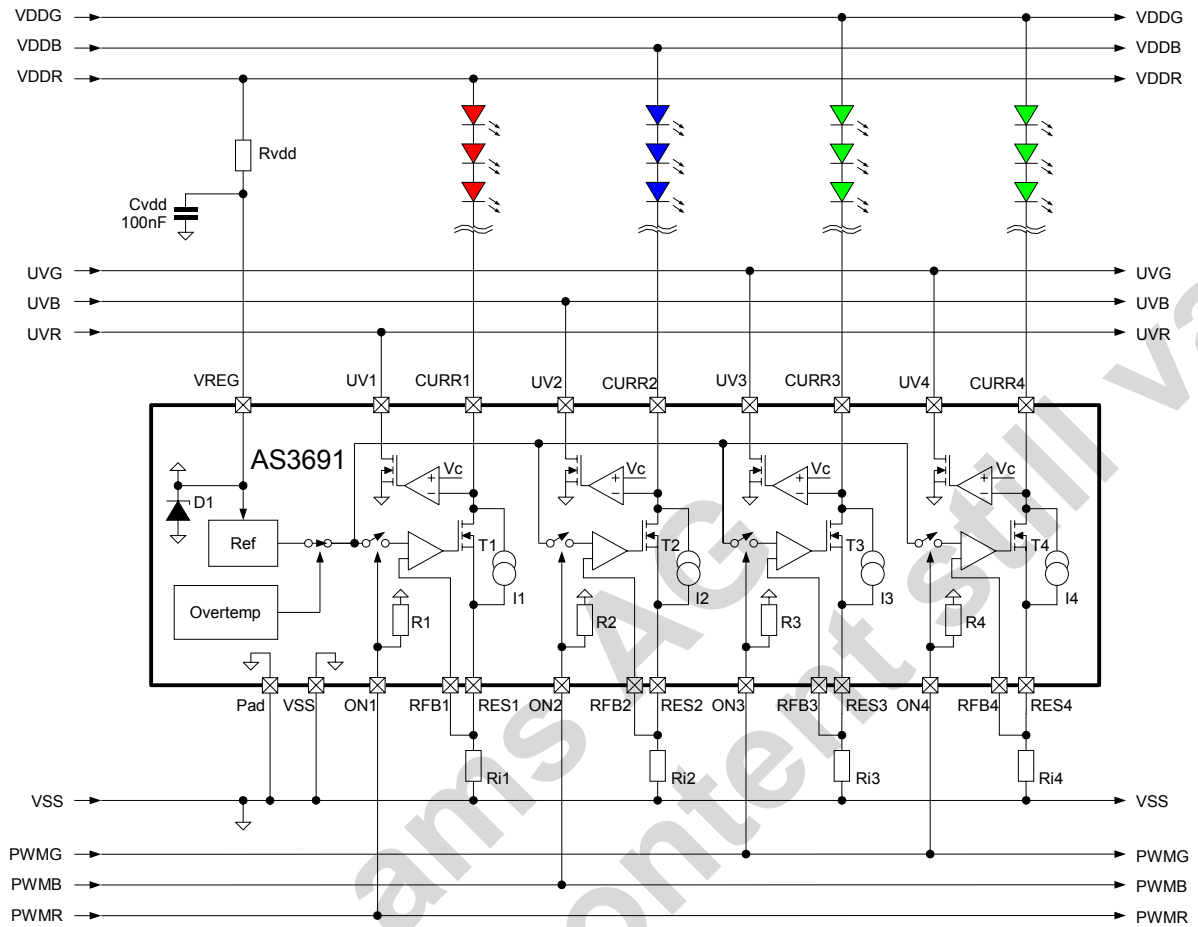

Table of Contents

1	General Description	1
2	Key Features.....	1
3	Applications.....	1
4	Application Diagrams	1
5	Pinout.....	4
5.1	Pin Assignments	4
5.2	Pin Descriptions	4
6	Characteristics	6
6.1	Absolute Maximum Ratings	6
6.2	Operating Conditions	6
6.3	Electrical Characteristics.....	7
7	Typical Operation Characteristics	8
8	Detailed Functional Description	12
8.1	Shunt Regulator	12
8.2	Overtemperature Protection.....	12
8.3	Automatic Supply Regulation.....	13
9	Application Information	14
9.1	Design Example.....	15
9.1.1	Using Automatic Supply Regulation.....	16
9.2	Layout Recommendations	16
10	Package Drawings and Markings	17
10.1	QFN 4x4 Package Drawings and Marking	17
10.2	ePTSSOP Package Drawings and Marking.....	19
10.3	DIE Delivery.....	20
11	Ordering Information	21

Revision History

Revision	Date	Owner	Description
2.3	30.10.2007	ptr	- Added Trays as delivery option (order code AS3691A-ZQFT)

5 Pinout

5.1 Pin Assignments

Figure 3 – Pin Usage

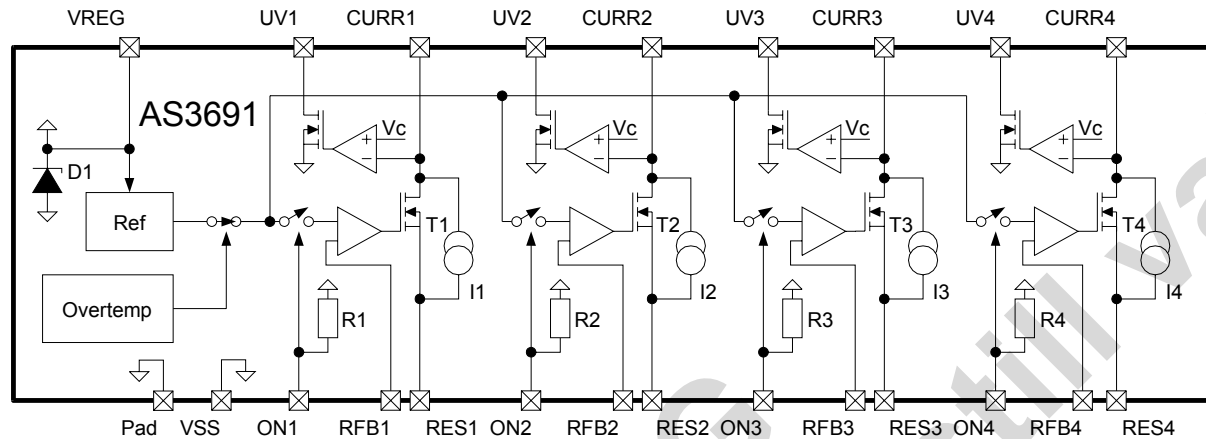

5.2 Pin Descriptions

Table 1 – Pin Type Descriptions

Pin Type	Description
AI/O	Analog Pin
AI	Analog Input Pin
AO	Analog Output Pin
DI	Digital Input
S	Supply Pin

Table 2 – Pin Descriptions

Pin Number QFN Package	Pin Number ePTSSOP Package	Pin Name	Type	Description
1	10	CURRE1	AI/O	Current Source 1 Output
2	11	RFB1	AI	Connect to current set resistor R1 directly at resistor itself
3	12	nc	nc	Leave open
4	13	RFB4	AI	Connect to current set resistor R4 directly at resistor itself
5	14	CURRE4	AI/O	Current Source 4 Output
6	15	RES4	AI/O	Connect to current set resistor R4

Datasheet

Pin Number QFN Package	Pin Number ePTSSOP Package	Pin Name	Type	Description
7	16	ON4	DI	Current source CURR4 control; internal pullup resistor to VREG (can be left open, if CURR4 is always switched on) High ... 100% Current Low ... 5% Current
8	17	UV4	AO	Automatic supply regulation for CURR4; if not used, leave open
9	18	TEST	AI	Digital Test input; Leave open or connect to VSS; internal pulldown to VSS
10	19	UV3	AO	Automatic supply regulation for CURR3; if not used, leave open
11	20	ON3	DI	Current source CURR3 control; internal pullup resistor to VREG (can be left open, if CURR3 is always switched on) High ... 100% Current Low ... 5% Current
12	21	RES3	AI/O	Connect to current set resistor R3
13	22	CURR3	AI/O	Current Source 3 Output
14	23	RFB3	AI	Connect to current set resistor R3 directly at resistor itself
15	24	VREG	S	Shunt regulator supply; connect to Rvdd and Cvdd
16	1	RFB2	AI	Connect to current set resistor R2 directly at resistor itself
17	2	CURR2	AI/O	Current Source 2 Output
18	3	RES2	AI/O	Connect to current set resistor R2
19	4	ON2	DI	Current source CURR2 control; internal pullup resistor to VREG (can be left open, if CURR2 is always switched on) High ... 100% Current Low ... 5% Current
20	5	UV2	AO	Automatic supply regulation for CURR2; if not used, leave open
21	6	VSS	S	VSS Supply connection
22	7	UV1	AO	Automatic supply regulation for CURR1; if not used, leave open
23	8	ON1	DI	Current source CURR1 control; internal pullup resistor to VREG (can be left open, if CURR1 is always switched on) High ... 100% Current Low ... 5% Current
24	9	RES1	AI/O	Connect to current set resistor R1
Pad	Pad	VSS	S	VSS Supply connection; add as many vias to ground plane as possible

6 Characteristics

6.1 Absolute Maximum Ratings

Stresses beyond those listed in Table 1 may cause permanent damage to the device. These are stress ratings only, and functional operation of the device at these or any other conditions beyond those indicated in Section 5 Electrical Characteristics is not implied.

Exposure to absolute maximum rating conditions for extended periods may affect device reliability.

Table 3 – Absolute Maximum Ratings

Symbol	Parameter	Min	Max	Unit	Note
VDDMAX	Supply for LEDs	-0.3	>17	V	See notes ¹
VINVREG	VREG Supply voltage	-0.3	7.0	V	Applicable for pin VREG
VIN5V	5V Pins	-0.3	VREG+0.3V	V	Applicable for 5V pins ²
VIN15V	15V Pins	-0.3	17	V	Applicable for CURR1, CURR2, CURR3 and CURR4
IIN	Input Pin Current	-25	+25	mA	At 25°C, Norm: Jedec 17
TSTRG	Storage Temperature Range	-55	125	°C	
	Humidity	5	85	%	Non condensing
VESD	Electrostatic Discharge	-2000	2000	V	Norm: MIL 883 E Method 3015
PT	Total Power Dissipation		2.0	W	At 50°C, no airflow for QFN24 on two layer FR4-Cu PCB ³
PDERATE	PT Derating Factor		23	mW/°C	See notes ³
TBODY	Body Temperature during Soldering		260	°C	according to IPC/JEDEC J-STD-020C

Notes:

1. As the AS3691 is not directly connected to this supply. Only the parameters VINVREG, VIN5V and VIN15V have to be guaranteed by the application
2. All pins except CURR1, CURR2, CURR3 and CURR4
3. Depending on actual PCB layout and especially number of vias below the exposed pad – see layout recommendations; can be improved e.g. with AI-PCB or airflow

6.2 Operating Conditions

Table 4 – Operating Conditions

Symbol	Parameter	Min	Typ	Max	Unit	Note
VDD	Main Supply			Not Limited	V	Supply is not directly connected to the AS3691 – see section ‘Shunt Regulator’
VDDTOL	Main Supply Voltage Tolerance	-20		+20	%	Applies only for supply VREG is connected via Rvdd
VREGINT	Supply (shunt regulated by AS3691)	5.0	5.2	5.4	V	If internally (shunt-)regulated by D1
VREGEXT		4.5	4.75	5.0	V	If externally supplied
IVREG	Supply Current			2.5	mA	Excluding current through shunt regulator (D1) – see section ‘Shunt Regulator’
TAMB	Ambient Temperature	-20	25	85	°C	

6.3 Electrical Characteristics

Table 5 – Analog Electrical Characteristics

Symbol	Parameter	Min	Typ	Max	Unit	Note
V _{CURR}	Current Source CURR1 to CURR4 Voltage Compliance	0.9		15.0	V	at 400mA; total power dissipation limit PT must not be exceeded
		0.41		15.0	V	at 100mA
I _{CURR}	Current Source Range	10		400 ⁽¹⁾	mA	ONx = high I _{CURRx} = 250mV / R _{ix} (x=1...4)
I _{CURR,TOL}	Current Source Tolerance	-0.5		+0.5	%	@25°C T _{JUNCTION} , excluding variation of external resistors; V(CURRx) ≤ 4.0V
		-1.5		+1.5	%	-20°C to +100°C ⁽²⁾ T _{JUNCTION} , -20°C to +85°C T _{AMB} , excluding variation of external resistors; V(CURRx) ≤ 4.0V
V _C	Automatic Supply Regulation compare voltage		1.0		V	See section 'Automatic Supply Regulation'
V _{C,GAIN}	Automatic Supply Regulation gain		2.0		mA/V	Voltage to current ratio; output current range typ 0 to 200uA
I ₁₋₄	Parallel Current			1.0	mA	V(CURRx) ≤ 15V
				0.1	mA	V(CURRx) ≤ 5.0V
TOVTEMP	Overtemperature Limit		140		°C	Maximum junction temperature

Notes:

1. To obtain higher currents connect more than one current source in parallel
2. Accuracy at +100°C guaranteed by design and verified by laboratory characterization

Table 6 – Digital Input pins characteristics for pins ON1, ON2, ON3 and ON4

Symbol	Parameter	Min	Typ	Max	Unit	Note
V _{IH}	High Level Input voltage	2.3		V _{REG}	V	
V _{IL}	Low Level Input voltage	0.0		0.9	V	
R _{PU}	Pullup resistor		70		kΩ	Internal pullup resistor R1 to R4 to V _{REG}
f _{ON}	Input Frequency Range	0		20	kHz	This defines the actual input frequency seen on the input ON1 to ON4; the basic frequency to generate the PWM signal is not limited by this parameter

7 Typical Operation Characteristics

Figure 4 – Output Current versus Voltage on Current Source – High Current Range

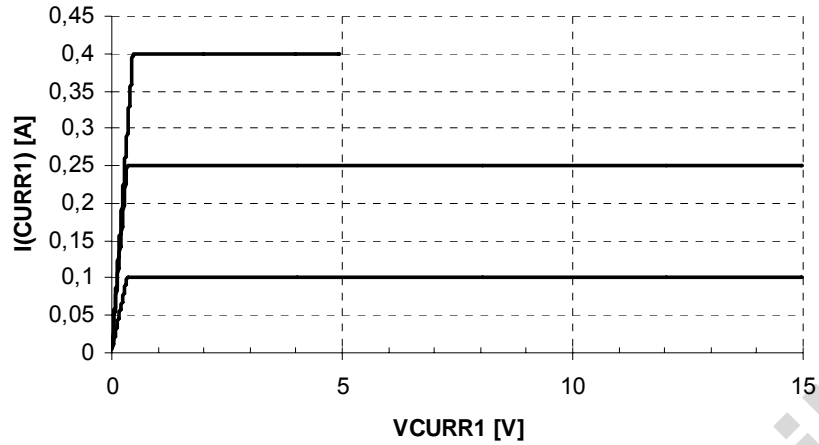

Figure 5 – Output Current versus Voltage on Current Source – Low Current Range

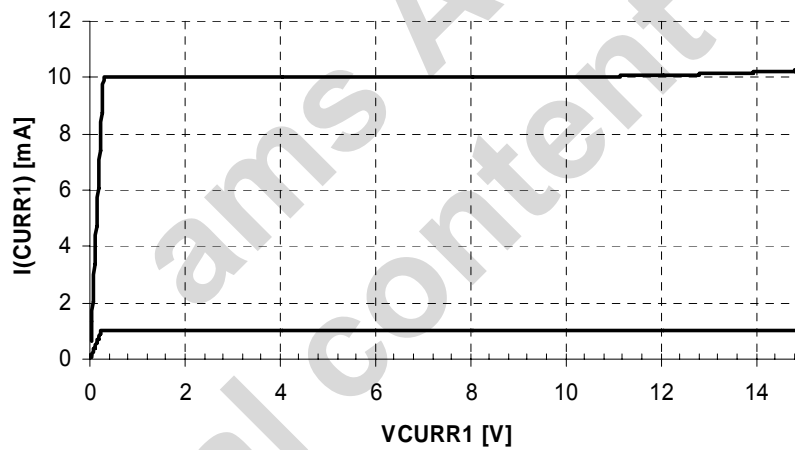
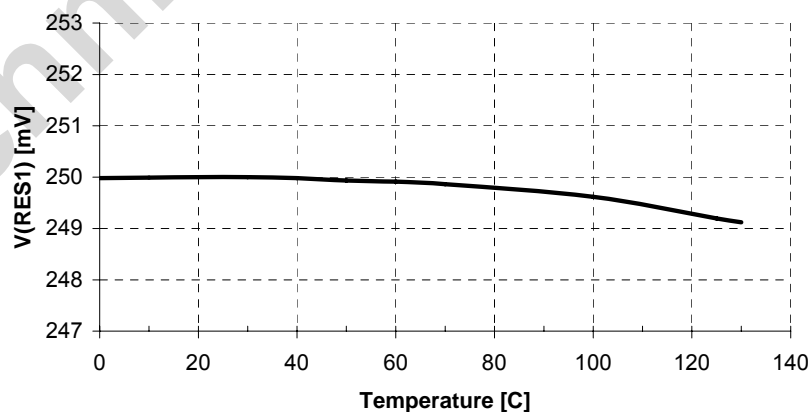

Figure 6 – Internal voltage reference versus Temperature, $V(\text{CURR1}) = 2.0\text{V}$, $R_{i1} = 250\Omega$



$$I_{\text{CURR1}} = \frac{V(\text{RES1})}{R_{i1}}$$

Figure 7 – Output Current versus Temperature, $V(\text{CURR1}) = 2.0\text{V}$, $R_{i1} = 2.5\Omega$ (Note: temperature coefficient of $R_{i1} = -200\text{ppm}/^\circ\text{C}$)

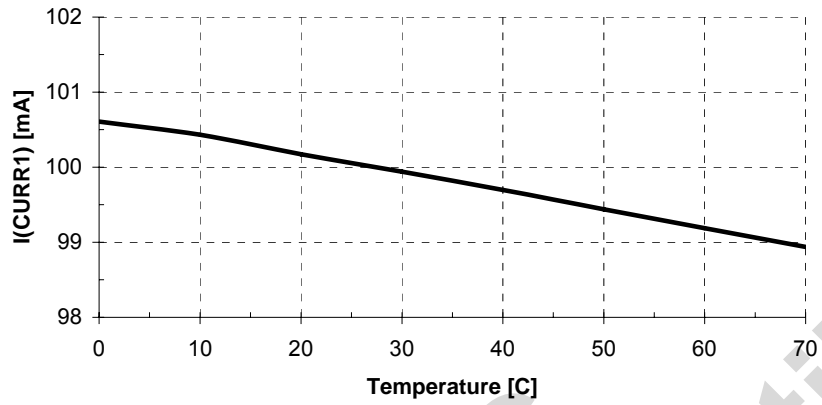

Figure 8 – Cross coupling of pwm on CURR1 to CURR2; $I(\text{CURR1}) = 100\text{mA}$ to 4mA , $I(\text{CURR2}) = 100\text{mA}$; AS3691A

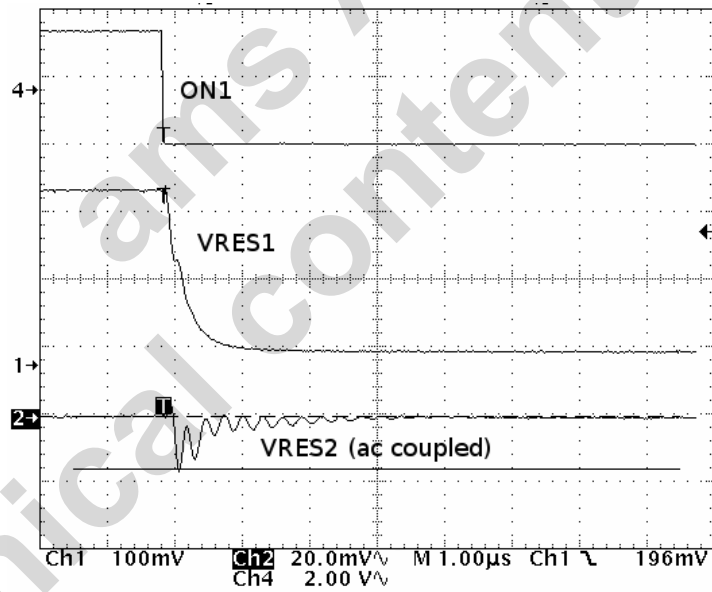

Figure 9 – PWM performance of Current Source CURRE1, I(CURRE1) changed between 400mA (ON1=1) and 20mA (ON1=0); AS3691A

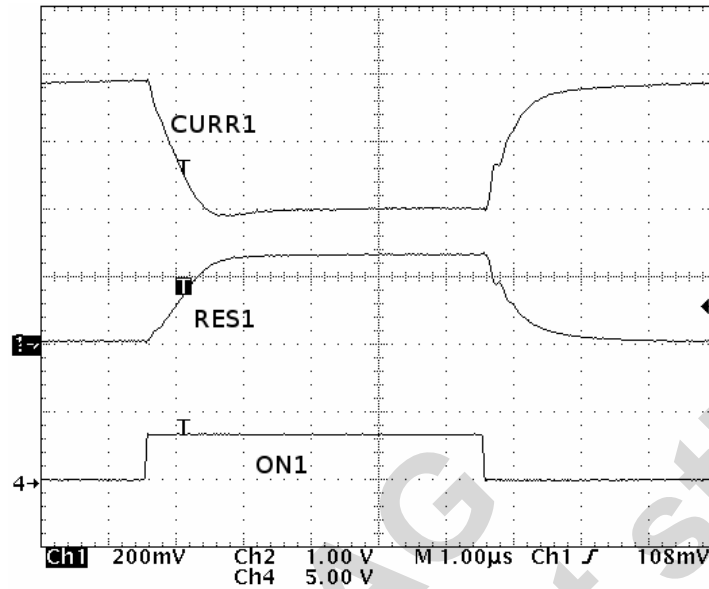

Figure 10 – Shunt Regulator Voltage VREG versus supply VDD with Rfb=1kΩ

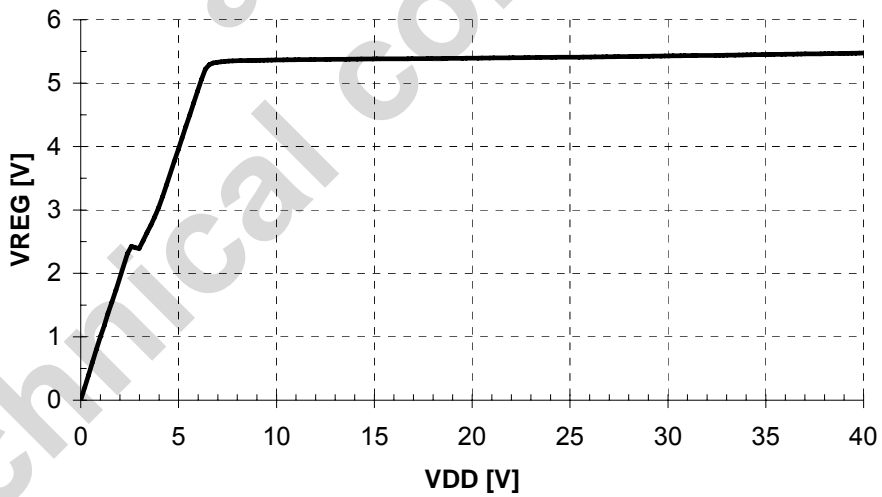

Figure 11 – Automatic Supply Regulation dynamic performance using DCDC converter in regulation loop (as in section 7.3)
 R1 = 47kΩ, R2 = 10kΩ, R3 = 5kΩ, R4 = 500Ω, C1 = 1uF, I(CURR1) = 400mA/20mA (Ri1=0.625Ω)
 3 OSRAM Golden Dragon in series as load between CURR1 and VDD
 Input signal on pin ON1: PWM signal with f=10kHz, 80% duty cycle

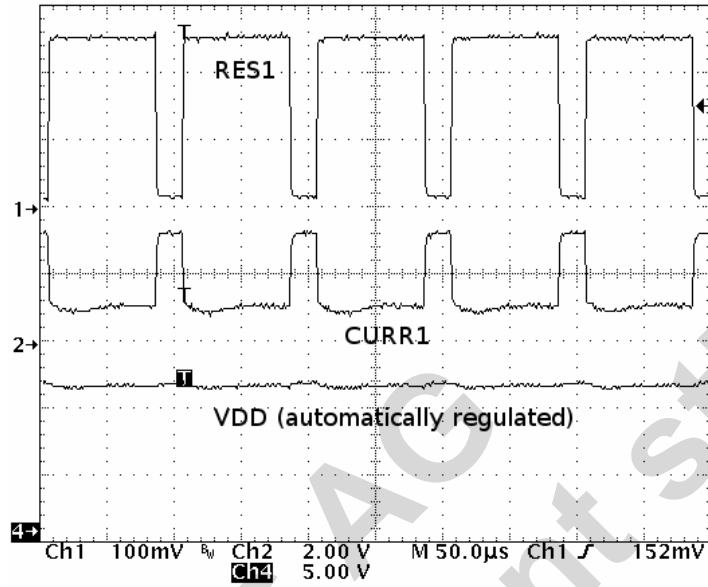
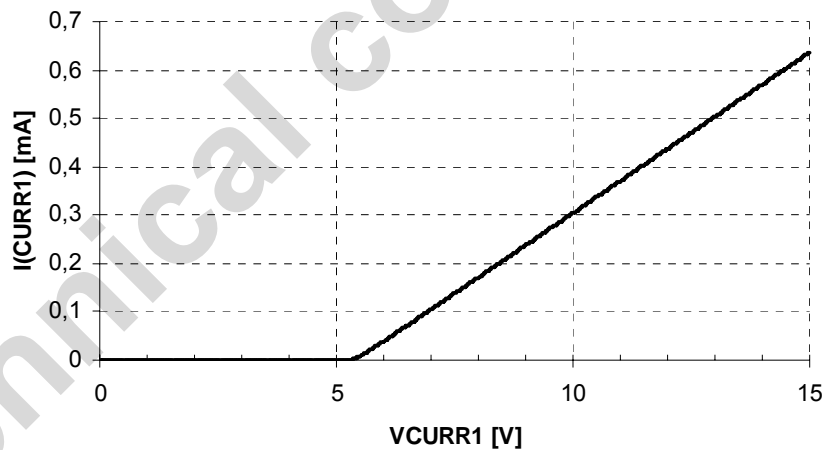

Figure 12 – Parallel Current I1 to I4 (for measurement of I1 remove current set resistor R1)



8 Detailed Functional Description

The AS3691 includes four high precision current sources (sinks). Each current source is set by an external resistor. For internal power supply an internal shunt regulator is used. Optionally an additional 5V device can be supplied as well with this shunt regulator.

The current sources are individually controlled by four ON inputs. If the inputs ON are high or left open, then the current is set as follows:

$$ICURR_{1-4} = \frac{250mV}{Ri_{1-4}}$$

Setting the input ON to low the current is

$$ICURR_{1-4} = \frac{10.0mV}{Ri_{1-4}} \quad \text{for part numbers starting with AS3691A}$$

The current is not zero to avoid high voltage jumps on the LEDs and supplies and therefore reduce EMI.

$$ICURR_{1-4} = \frac{0.0mV}{Ri_{1-4}} + I_{1-4} = I_{1-4} \quad \text{for part numbers starting with AS3691B; } I_{1-4} \text{ is the parallel current (see above Figure 11)}$$

8.1 Shunt Regulator

The supply of the AS3691 is generated from the high voltage supply. To obtain a 5V regulated supply, a series resistor Rvdd is used together with an internal zener diode (shunt regulator principle). An external capacitor Cvdd is used to filter the supply on the pin VREG.

The external resistor Rvdd has to be chosen according to the following formula:

$$Rvdd = \frac{VDD_{MIN} - VVREGINT_{MAX}}{IVREG_{MAX}} \quad VDD_{MIN} \text{ is the minimum voltage of the supply, where Rvdd is connected}$$

This ensures enough supply current (IVREGMAX) for the AS3691 under minimum supply voltage VDDMIN.

If a stable 5V supply within the operating conditions limits of VREGEXT is already existing in the system it is possible to supply the AS3691 directly. In this case remove the resistor Rvdd and connected this supply directly to VREG.

8.2 Overtemperature Protection

If the junction temperature inside the AS3691 rises above TOVTEMP, the current sources are switched off.

8.3 Automatic Supply Regulation

The purpose of the automatic supply regulation is to minimize the voltage supply to reduce the voltage across the current sources of the AS3691 (CURR1-CURR4 to VSS) and therefore reduce the power dissipation of the AS3691 and the complete system. The AS3691 automatically controls the minimum required supply voltage for the different led strings to support very power efficient systems for lighting using the following circuit (any off-the-shelf dc/dc converter or ldo with adjustable output voltage can be used):

Figure 13 – Automatic Supply Regulation Circuit

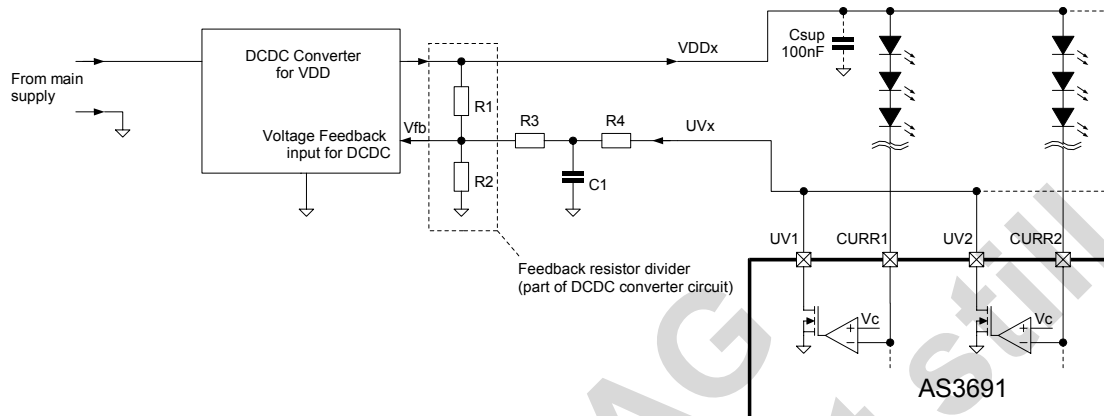

The function of this circuit is as follows:

All channels, which are connected to the supply VDDx should have their respective UV pin connected together to UVx (see above Figure and Section 'Application Schematic'). If any of these current sources has a too low voltage, it gradually pulls the wire UVx low. (The analog gain between the current source CURRx and output UVx is defined by the parameter $V_{C,GAIN}$.)

Therefore the feedback pin Vfb of the dc/dc converter is pulled low and the dc/dc converter compensates this by increasing the voltage on VDDx to obtain the same feedback voltage as before.

To stabilize this regulation loop, the low pass filter build by C1 and R4 is used (this should be the dominant pole for the regulation loop).

The minimum output voltage $VDDx_{min}$ can be set accurately by the resistors R1 and R2. The maximum output voltage $VDDx_{max}$ is set by R1, R2, R3 and R4 (V_{ref} is the internal voltage reference of the DCDC converter; usually $V_{ref} = V_{fb}$):

$$VDDx_{MIN} = V_{ref} \frac{R_1 + R_2}{R_2}$$

$$VDDx_{MAX} = V_{ref} \frac{R_1 + R_2 \parallel (R_3 + R_4)}{R_2 \parallel (R_3 + R_4)}$$

Therefore even if a led string is broken (then UVx is forced to 0V) or some leds are shorted, the supply always stays within the limits $VDDx_{MIN}$ and $VDDx_{MAX}$.

9 Application Information

Typical Application Schematic

For RGB leds (and a white color balancing circuit) use the following application schematic including automatic supply regulation (feedback paths UVR, UVG, UVB):

Figure 14 – Typical AS3691 System for RGB (back-)lighting; several AS3691 can be cascaded

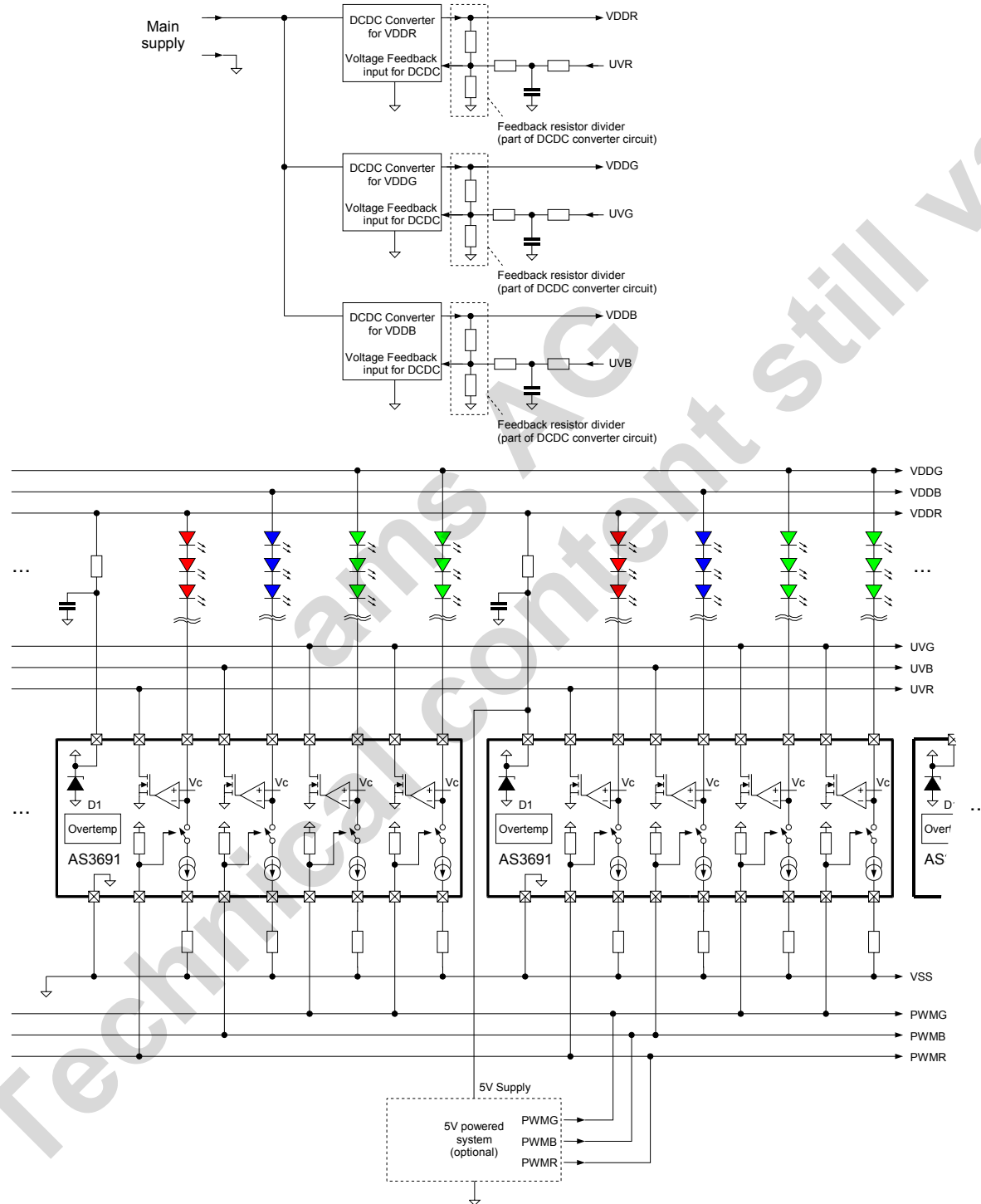

A typical AS3691 for single color leds can be done as follows using automatic supply regulation (feedback path UV):

Figure 15 – Typical AS3691 system for single color leds and supply regulation loop; several AS3691 can be cascaded

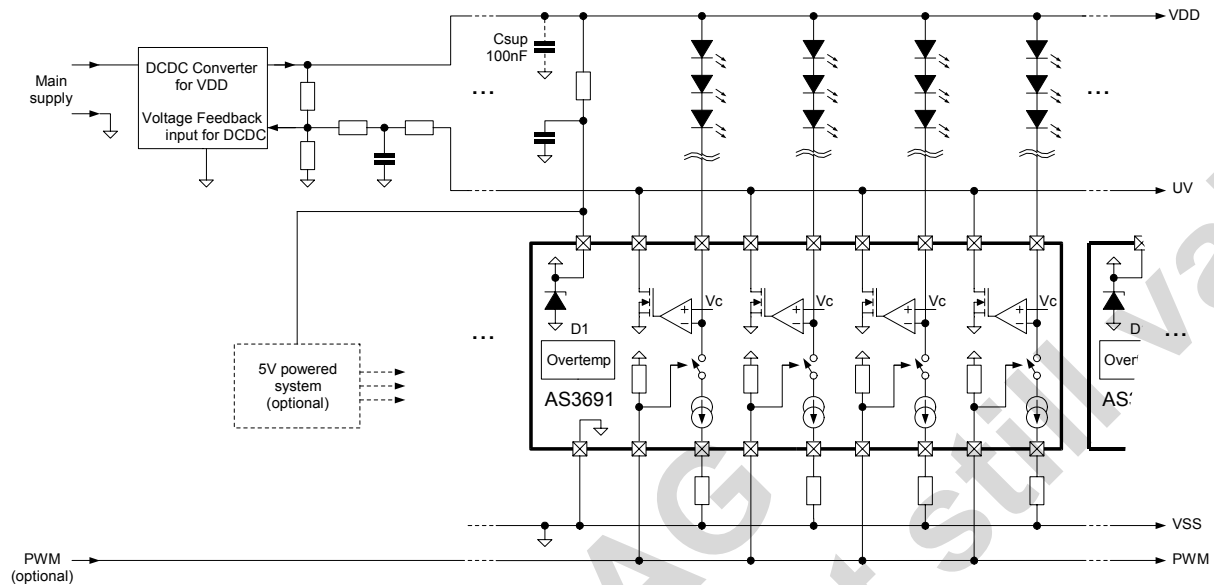

Note: Csup (100nF) is only required, if there are long wires (>0.3m) between the DCDC converter and the AS3691. The wire length between the Csup capacitor and the CURRx pin on AS3691 should not exceed 0.3m. If this cannot be guaranteed, add additional capacitors of 100nF to the pins CURRx.

9.1 Design Example

Assume a single color leds application (4 times 3 leds in series, each 100mA with U_f ranging from $U_{fmin}=3.2V$ to $U_{fmax} = 3.8V$) with a fixed supply. First choose the external current set resistor with the following formula:

$$R_{i-4} = \frac{250mV}{ICURR_{1-4}}$$

So for a current of 100mA, use a resistor of 2.5Ω; 1/8W rated resistors are suitable (even up to 400mA).

Then calculate the required voltage of the power supply. The minimum voltage on the current sink for guaranteed operation is 0.41V ($V_{CURR @100mA}$) and the maximum forward voltage of the LEDs is assumed to be $U_{fmax} = 3.8V$. Therefore $3 \cdot 3.8V + 0.41V = 11.81V$.

As this is the required minimum voltage of the power supply, add all the tolerances on top. Assumed +/-10% supply tolerance results in a power supply with nominal 13V (to have at least 11.81V in worst case). Using the following formula to calculate the external shunt resistor

$$R_{vdd} = \frac{VDD_{MIN} - VREGINT_{MAX}}{IVREG_{MAX}} = \frac{VDD_{MIN} - 5.4V}{2.5mA}$$

VDD_{MIN} is the minimum voltage of the power supply, where R_{vdd} is connected

obtains 2564Ω. The nearest lower(!) available value is 2.4kΩ. For C_{vdd} use

$$C_{vdd} = 100nF$$

Csup (100nF) is only required, if there are long connections between the DCDC converter and the AS3691 (>0.3m). The wire length between the Csup capacitor and the CURRx pin on AS3691 should not exceed 0.3m. If this cannot be guaranteed, add additional capacitors of 100nF to the pins CURRx.

Then calculate the maximum power dissipation inside the AS3691. The worst case is maximum voltage supply (13V + 10%) together with LEDs with minimum forward voltage U_{fmin} :

For these conditions the maximum voltage on any current source (CURR1 to CURR4) is

$$VCURR_{MAX} = (1 + VDD_{TOL}) VDD - n U_{fmin} \quad \text{Not using automatic supply regulation}$$

In our example $14.3V - 9.6V = 4.7V$. The maximum power dissipation inside the AS3691 is now (assuming 4 identical strings)

$$P_{MAX} = 4 VCURR_{MAX} ICURR$$

In our example 1.88W. As

$$T_{MAX} = \frac{PT - P_{MAX}}{P_{DERATE}} + 50^{\circ}C$$

For PT and PDERATE see Absolute Maximum Ratings

the system can be operated safely up to an ambient temperature of 55°C assuming worst case power supplies and worst case leds. Please note: If the internal junction temperature of the AS3691 rises too high, the AS3691 will switch off the current sources for protection (it will never damage the AS3691).

9.1.1 Using Automatic Supply Regulation

For the identical system using the automatic supply regulation, the supply is regulated to minimize the power dissipation of the system. Therefore the tolerance of the VDD supply and also the variation in forward voltages of the LEDs can be ignored (only the difference in one lot of leds is still important, as the four strings are connected in parallel to the power supply). Assume a difference of $\Delta U_f = 0.2V$ of forward voltage of the leds in one lot, then calculate the maximum voltage on the current source of the AS3691 (CURR1 to CURR4) with

$$VCURR_{MAX} = n \Delta U_f + V_C$$

Using automatic supply regulation
 ΔU_f variation of LED forward voltage
 in one lot (for one application)
 V_C is internal set voltage (1.0V)

to be 1.6V. Using the identical formulas as above, P_{MAX} now is 0.64W and T_{MAX} is 110°C.

Therefore using automatic supply regulation, the ambient temperature can be up to 110°C under identical conditions.

9.2 Layout Recommendations

See austriamicrosystems 'AN3691_Tech_Module Description' as a layout example for the AS3691.

Layout Checklist

1. Use the bottom layer as ground plane and minimize the number and the length of connections within this layer
2. Do as many vias as possible on the exposed pad (for thermal performance) to the ground plane
3. Connect RFBx and RESx together at the current set resistor Rix (see above recommended layout)
4. The ground connections of the current set resistors should be as close to the AS3691 as possible
5. The ground connection of the capacitor Cvdd should be as close as possible to the AS3691
6. Minimize Area build by 'Csup VSS connection – Csup Supply Connection – LEDs – CURRx – Csup VSS connection' (to minimize inductance in this path)

10 Package Drawings and Markings

10.1 QFN 4x4 Package Drawings and Marking

Figure 16 – QFN 24 – 4x4mm

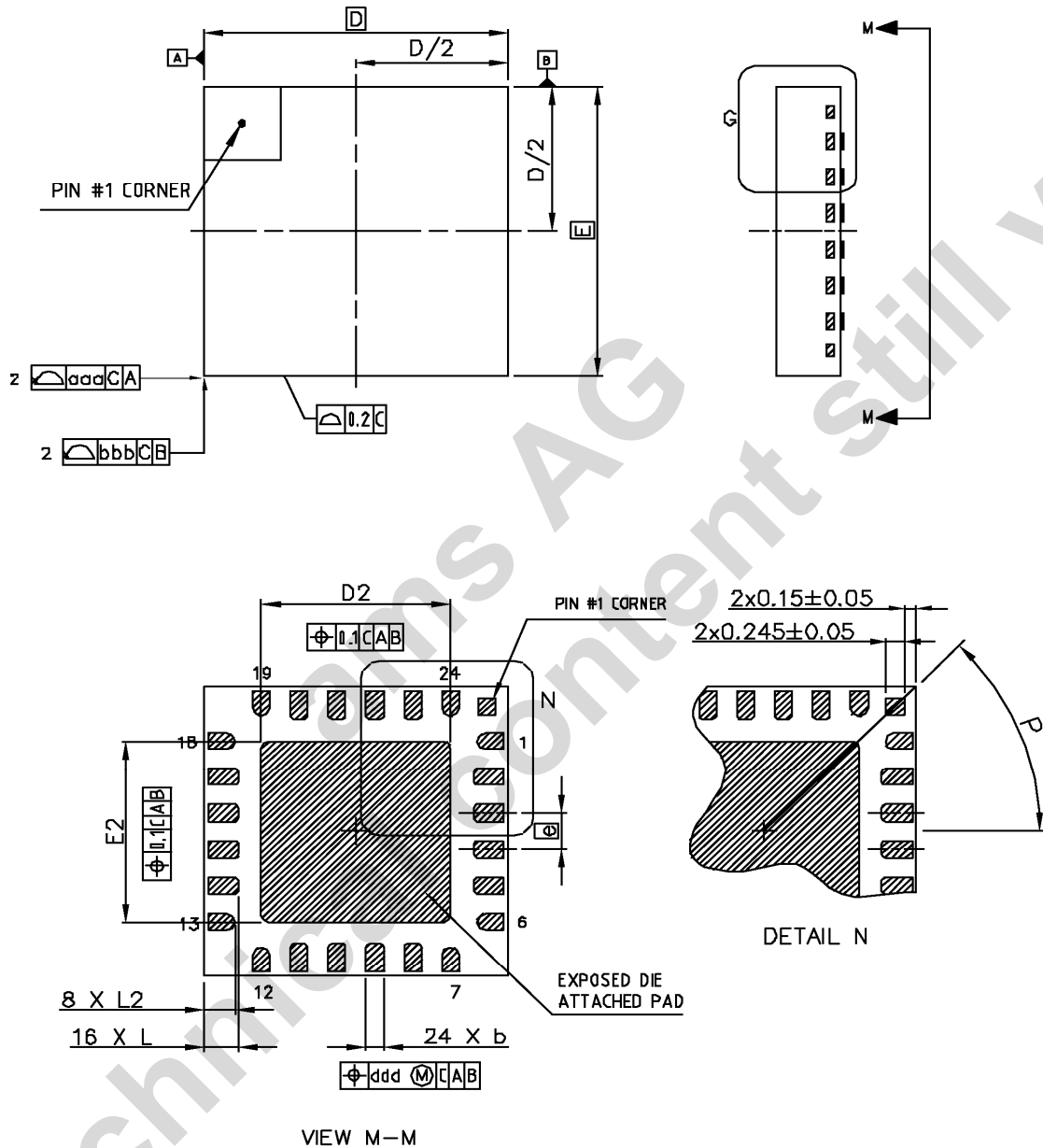

Marking:

Line 1: austriamicrosystems Logo
 Line 2: AYWWIZZ
 A = Pb-Free Identifier
 Y = Year
 WW = Week
 I = Plant Identifier
 ZZ = Letters of Free Choice
 Line 3: AS3691, AS3691A or AS3691B

Figure 17 – QFN 24 – 4x4mm Detail Dimensions

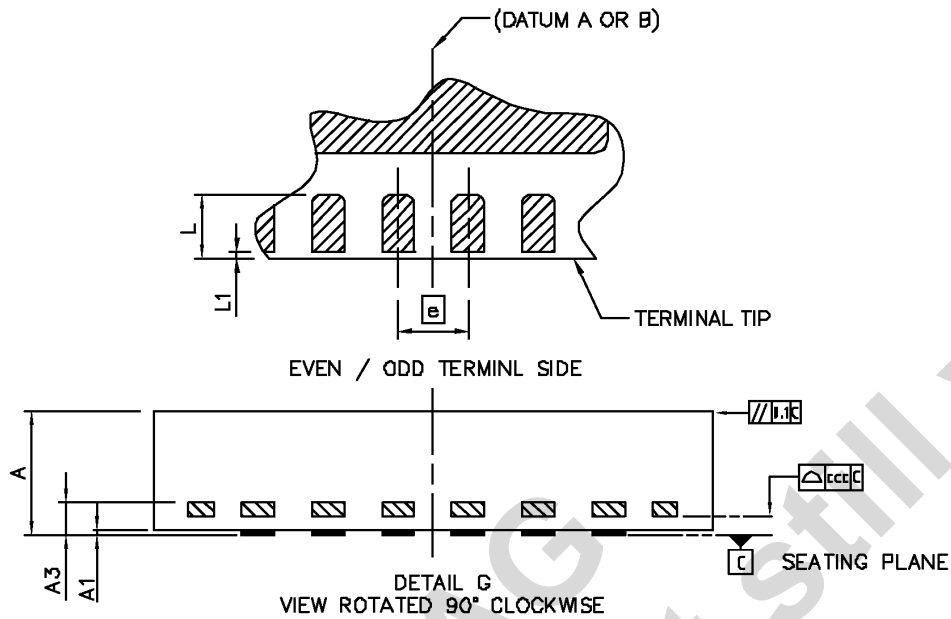

DIM	MIN	NOM	MAX	NOTES		
A	0.80	0.85	0.90	1.0 DIMENSIONING & TOLERANCEING CONFIRM TO ASME Y14.5M-1994. 2.0 ALL DIMENSIONS ARE IN MILLIMETERS. ANGLES ARE IN DEGREES.		
A1	0.00	0.02	0.05			
A3	0.203 REF.					
b	0.18	0.23	0.30			
D	4.0 BSC					
E	4.0 BSC			3.0 DIMENSION b APPLIES TO METALLIZED TERMINAL AND IS MEASURED BETWEEN 0.25mm AND 0.30mm FROM TERMINAL TIP. DIMENSION L1 REPRESENTS TERMINAL FULL BACK FROM PACKAGE EDGE UP TO 0.1mm IS ACCEPTABLE.		
e	0.50 BSC					
D2	2.40	2.50	2.60	4.0 COPLANARITY APPLIES TO THE EXPOSED HEAT SLUG AS WELL AS THE TERMINAL.		
E2	2.40	2.50	2.60			
L	0.40	0.45	0.50	5.0 RADIUS ON TERMINAL IS OPTIONAL.		
L1	0.03	0.05	0.08			
L2	0.35	0.40	0.45			
P	45° REF					
aaa	0.10					
bbb	0.10					
ccc	0.08					
ddd	0.10					
				UNIT	DIMENSION AND TOLERANCE	REFERENCE DOCUMENT
				Millimeter(mm)	ASME Y14.5M	JEDEC MO-220

10.2ePTSSOP Package Drawings and Marking

Figure 18 – ePTSSOP Package Drawing

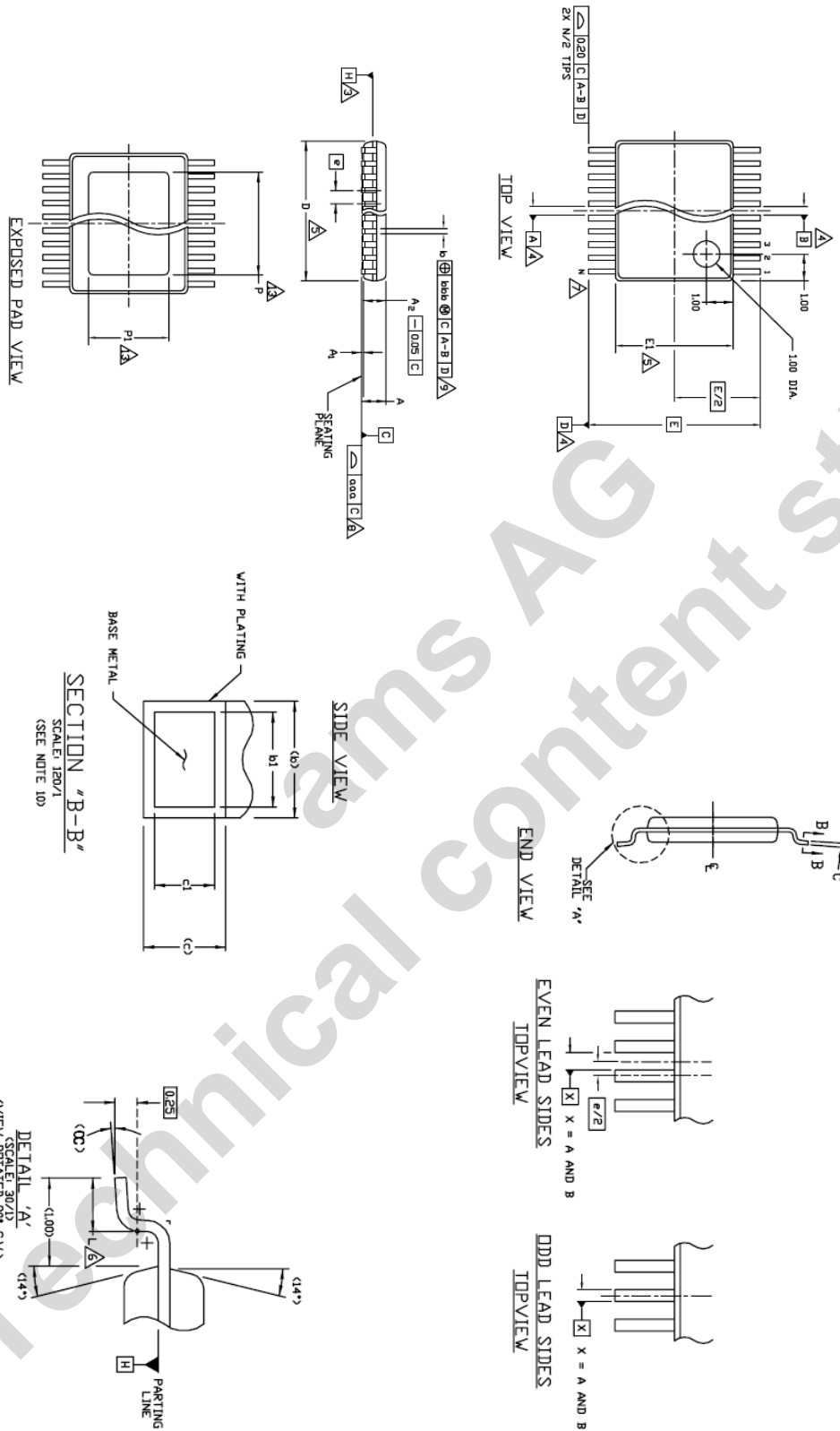

Marking:

Line 1: austriamicrosystems Logo
 Line 2: AYWWIZZ
 A = Pb-Free Identifier
 Y = Year
 WW = Week
 I = Plant Identifier
 ZZ = Letters of Free Choice
 Line 3: AS3691, AS3691A or AS3691B

Figure 19 – ePTSSOP Package Drawing Detail Dimensions

SYMBOL	COMMON DIMENSIONS			NOTE VARIATIONS	D			P	P1	7
	MIN.	NOM.	MAX.		MIN.	NOM.	MAX.	MAX.	MAX.	N
A	—	—	1.10	AA/AAT	2.90	3.00	3.10	1.59	3.2	8
A ₁	0.05	—	0.15	AB-1/ABT-1	4.90	5.00	5.10	3.1	3.0	14
A ₂	0.85	0.90	0.95	AB/ABT	4.90	5.00	5.10	3.0	3.0	16
aaa	0.076			AC/ACT	6.40	6.50	6.60	4.2	3.0	20
b	0.19	—	0.30	AD/ADT	7.70	7.80	7.90	5.5	3.2	24
b ₁	0.19	0.22	0.25	AE/AET	9.60	9.70	9.80	5.5	3.0	28
bbb	0.10									
c	0.09	—	0.20							
c ₁	0.09	0.127	0.16							
D	SEE VARIATIONS			5						
E ₁	4.30	4.40	4.50	5						
e	0.65 BSC									
E	6.40 BSC									
L	0.50	0.60	0.70	6						
N	SEE VARIATIONS			7						
P	SEE VARIATIONS			13						
P ₁	SEE VARIATIONS			13						
α	0°	—	8°							

NOTES:

- DIE THICKNESS ALLOWABLE IS 0.279±0.0127 (0.110±0.005 INCHES)
- DIMENSIONING & TOLERANCES PER ASME, Y14.5M-1994.
- DATUM PLANE H LOCATED AT MOLD PARTING LINE AND COINCIDENT WITH LEAD, WHERE LEAD EXITS PLASTIC BODY AT BOTTOM OF PARTING LINE.
- DATUM A-B AND D TO BE DETERMINED WHERE CENTERLINE BETWEEN LEADS EXITS PLASTIC BODY AT DATUM PLANE H.
- *D* & *E₁* ARE REFERENCE DATUM AND DO NOT INCLUDE MOLD FLASH OR PROTRUSIONS, AND ARE MEASURED AT THE BOTTOM PARTING LINE. MOLD FLASH OR PROTRUSIONS SHALL NOT EXCEED 0.15mm ON D AND 0.25mm ON E PER SIDE.
- DIMENSION IS THE LENGTH OF TERMINAL FOR SOLDERING TO A SUBSTRATE.
- TERMINAL POSITIONS ARE SHOWN FOR REFERENCE ONLY.
- FORMED LEADS SHALL BE PLANAR WITH RESPECT TO ONE ANOTHER WITHIN 0.076mm AT SEATING PLANE.
- THE LEAD WIDTH DIMENSION DOES NOT INCLUDE DAMBAR PROTRUSION. ALLOWABLE DAMBAR PROTRUSION SHALL BE 0.07mm TOTAL IN EXCESS OF THE LEAD WIDTH DIMENSION AT MAXIMUM MATERIAL CONDITION. DAMBAR CANNOT BE LOCATED ON THE LOWER RADIUS OR THE FOOT. MINIMUM SPACE BETWEEN PROTRUSIONS AND AN ADJACENT LEAD SHOULD BE 0.07mm FOR 0.65MM PITCH, 0.08mm FOR 0.50MM PITCH AND 0.07mm FOR 0.40MM PITCH PACKAGES. SEE SECTION *B-B*.
- SECTION *B-B* TO BE DETERMINED AT 0.10 TO 0.25 MM FROM THE LEAD TIP.
- CONTROLLING DIMENSION: MILLIMETERS.
- THIS PART IS COMPLIANT WITH JEDEC SPECIFICATION MO-153 VARIATIONS AA/AAT, AB-1/ABT-1, AB/ABT, AC/ACT, AD/ADT, AE/AET, BC-1/BCT-1, BD-1/BDT-1, BE/BET, CA/CAT & CD/CDT AND MO-194 VARIATIONS AC/ACT & AF/AFT.
- DIMENSIONS *P* AND *P₁* ARE THERMALLY ENHANCED VARIATIONS. VALUES SHOWN ARE MAXIMUM SIZE OF EXPOSED PAD WITHIN LEAD COUNT AND BODY SIZE. END USER SHOULD VERIFY AVAILABLE SIZE OF EXPOSED PAD FOR SPECIFIC DEVICE APPLICATION.

ALL DIMENSIONS IN MILLIMETERS

10.3 DIE Delivery

Please contact austriamicrosystems for die delivery.

11 Ordering Information

Table 7 – Ordering Information

Part Number	Marking	Package Type	Delivery Form	Description
AS3691A-ZQFP	AS3691A ¹⁾ -or- AS3691 ¹⁾	QFN 24 4x4mm	Tape and Reel in Dry Pack	Package Size = 4x4x0.85mm, Pitch = 0.5mm, Pb-Free; 10mV on VRES for ON=0
AS3691A-ZQFT	AS3691A	QFN 24 4x4mm	Trays in Dry Pack	Package Size = 4x4x0.85mm, Pitch = 0.5mm, Pb-Free; 10mV on VRES for ON=0
AS3691A-ZSDF ²⁾	(AS3691A)	Sorted Wafers	Cut Dies on Foil	Sorted Wafers; 10mV on VRES for ON=0
AS3691B-ZQFP	AS3691B	QFN 24 4x4mm	Tape and Reel in Dry Pack	Package Size = 4x4x0.85mm, Pitch = 0.5mm, Pb-Free; 0mV on VRES for ON=0
AS3691B-ZSDF ²⁾	(AS3691B)	Sorted Wafers	Cut Dies on Foil	Sorted Wafers; 0mV on VRES for ON=0
AS3691A-ZTSP ²⁾	AS3691A	ePTSSOP	Tape and Reel in Dry Pack	Enhanced Power TSSOP (with power pad), Body Size=4.4mm Pitch = 0.65mm, Pb-Free; 10mV on VRES for ON=0
AS3691B-ZTSP	AS3691B	ePTSSOP	Tape and Reel in Dry Pack	Enhanced Power TSSOP (with power pad), Body Size=4.4mm Pitch = 0.65mm, Pb-Free; 0mV on VRES for ON=0

Note:

- 1) AS3691 with 10mV on VRES for ON=0 can be marked with 'AS3691' or 'AS3691A' (identical behavior)
- 2) Contact austriamicrosystems for availability

Description:

AS3691V-CPPD

V ... AS3691 Version, either A or B
AS3691A: 10mV on VRES_x (x=1 to 4) if ON_x = 0 (see '7 Detailed Functional Description')
AS3691B: 0mV on VRES_x (x=1 to 4) if ON_x = 0 (see '7 Detailed Functional Description')

C ... Temperature range -20°C - 85°C

PP ... Package; QF for QFN, SD for sorted DIES, TS for enhanced Power TSSOP

D ... Delivery From; P for Tape&Reel in Dry Pack, F for cut dies on foil, T for Trays in Dry Pack

Copyright

Copyright © 1997-2007, austriamicrosystems AG, Schloss Premstaetten, 8141 Unterpremstaetten, Austria-Europe. Trademarks Registered ®. All rights reserved. The material herein may not be reproduced, adapted, merged, translated, stored, or used without the prior written consent of the copyright owner.

All products and companies mentioned are trademarks or registered trademarks of their respective companies.

Disclaimer

Devices sold by austriamicrosystems AG are covered by the warranty and patent indemnification provisions appearing in its Term of Sale. austriamicrosystems AG makes no warranty, express, statutory, implied, or by description regarding the information set forth herein or regarding the freedom of the described devices from patent infringement. Austriamicrosystems AG reserves the right to change specifications and prices at any time and without notice. Therefore, prior to designing this product into a system, it is necessary to check with austriamicrosystems AG for current information.

This product is intended for use in normal commercial applications. Applications requiring extended temperature range, unusual environmental requirements, or high reliability applications, such as military, medical life-support or lifesustaining equipment are specifically not recommended without additional processing by austriamicrosystems AG for each application. For shipments of less than 100 parts the manufacturing flow might show deviations from the standard production flow, such as test flow or test location.

The information furnished here by austriamicrosystems AG is believed to be correct and accurate. However, austriamicrosystems AG shall not be liable to recipient or any third party for any damages, including but not limited to personal injury, property damage, loss of profits, loss of use, interruption of business or indirect, special, incidental or consequential damages, of any kind, in connection with or arising out of the furnishing, performance or use of the technical data herein. No obligation or liability to recipient or any third party shall arise or flow out of austriamicrosystems AG rendering of technical or other services.



Contact Information

Headquarters

austriamicrosystems AG
A-8141 Schloss Premstätten, Austria
T. +43 (0) 3136 500 0
F. +43 (0) 3136 5692

For Sales Offices, Distributors and Representatives, please visit:
<http://www.austriamicrosystems.com/contact>