

AS3695C

16 channel white LED controller for LCD backlight

Product Specification, Confidential

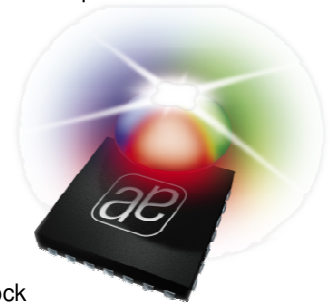

General Description

The AS3695C is a 16 channels precision LED controller for driving external FET/BJT in LCD-backlight panels. Dynamic power feedback controls the external power supply to guarantee best efficiency. Built in safety features include thermal shutdown as well as open and short LED detection. The device is programmable via serial interface.

- 16 Channel LED driver
- Output voltage max. 30V
- Output current only limited by external transistor
- Linear current setting using 10-bit DAC
- Current accuracy $\pm 0.5\%$ @ VDAC=250mV
- Channel to Channel current accuracy $\pm 0.2\%$
- BJT base current compensation
- Output slew rate programmable
- Current programmable with external resistor
- Digital current control with 16 independent PWM generators
- Free programmable 12 bit resolution (period, high time and delay)

- PWM-generator clock
 - Internal RC-oscillator
 - External Clock
 - PLL-synthesized clock from external signal
- H-Sync, V-Sync inputs to synchronize with TV-set
- Direct PWM mode
- Undervoltage detection (open LED)
- Undervoltage auto-turnoff
- Overvoltage detection (short LED)
- Overvoltage auto-turnoff
- Temperature shutdown
- Register lock/unlock function
- Fault interrupt output
- 2 configurable supply regulation feedback outputs
- SPI interface
- 4kV ESD at voltage sense inputs
- 2kV ESD an all other pins
- Package QFN64 9x9mm, 0.5mm pitch
LQFP64 14x14mm, 0.8mm pitch

Applications

LED backlighting for LCD – TV sets and monitors

1 Block diagram

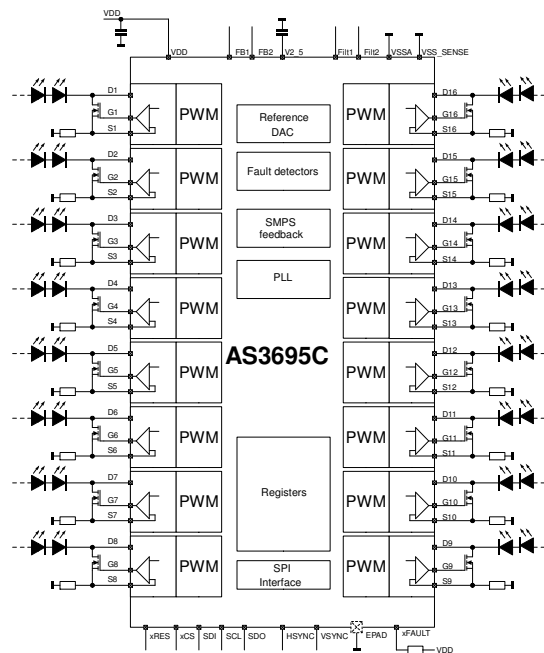

2 Typical application

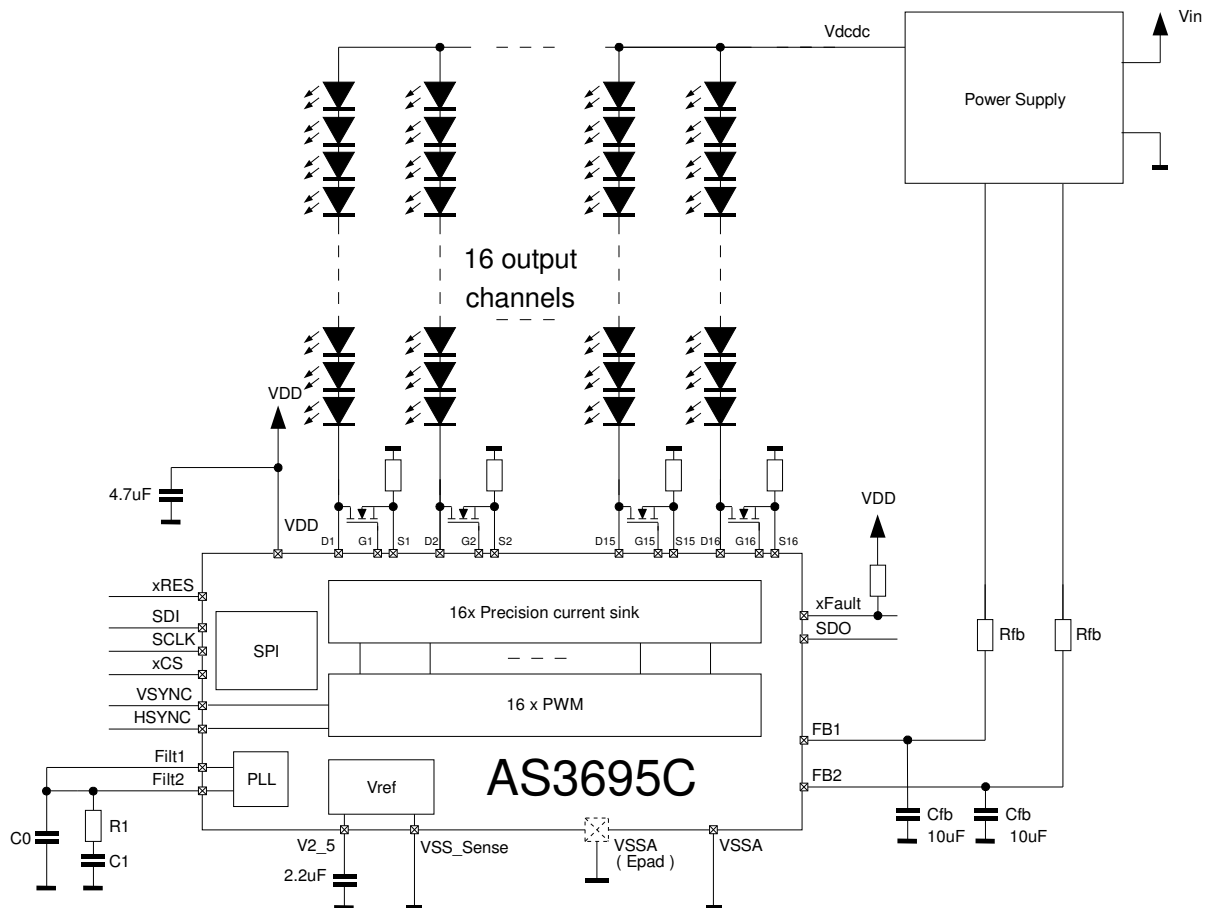

3 Electrical Characteristics

3.1 Absolute Maximum Ratings

Stresses beyond those listed may cause permanent damage to the device. These are stress ratings only, and functional operation of the device at these or any other conditions beyond those indicated in Section "Electrical Characteristics" is not implied. Exposure to absolute maximum rating conditions for extended periods may affect device reliability.

Symbol	Parameter	Min	Max	Unit	Note
Electrical Parameters					
VDDMAX	Supply voltage	-0.3	7	V	Applicable for pin VDD
VIN_2.5V	Maximum voltage	-0.3	2.8	V	Applicable for 2.5V pins ⁽¹⁾
VIN_5V	Maximum voltage	-0.3	VDD +0.3V	V	Applicable for 5V pins ⁽²⁾
VIN_30V	Maximum voltage	-0.3	30	V	Applicable for 30V pins ⁽³⁾
I _{latch}	Latch-Up immunity	-100	+100	mA	Norm: JEDEC 78
Electrostatic Discharge					
VESD_LV	Electrostatic Discharge on all 5V pins ⁽¹⁾	-2000	2000	V	Norm: MIL 883 E Method 3015 Human body model
VESD_HV	Electrostatic Discharge on 30V pins ⁽²⁾ against GND	-4000	4000	V	Norm: MIL 883 E Method 3015 Human body model
Continuous Power Dissipation (T_A = +70 °C)					
	Continuous Power Dissipation		1.5	W	P _T ⁽⁴⁾ for QFN64 Package
	Continuous Power Dissipation Derating factor		33	mW/°C	P _{DERATE} ⁽⁵⁾
Temperature Ranges and Storage Conditions					
T _J	Junctions temperature		+150	°C	
T _{STRG}	Storage Temperature Range	-55	+150	°C	
T _{BODY}	Package body temperature		260	°C	The reflow peak soldering temperature (body temperature) specified is in accordance with <i>IPC/JEDEC J-STD-020 "Moisture/Reflow Sensitivity Classification for Non-Hermetic Solid State Surface Mount Devices"</i> . The lead finish for Pb-free leaded packages is matte tin (100% Sn).
	Humidity non condensing	5	85	%	
	Moisture Sensitive Level		3		Represents a max. floor life time of 168h

Note: (1) Pins V2_5, Filt1, Filt2

(2) Pins xRES, SDI, SCLK, SDO, xCS, VSYNC, HSYNC, VDD, xFault, FB1, FB2, G1-G16, S1-D16

(3) Pins D1 – D16

(4) Depending on actual PCB layout and PCB used

(5) P_{DERATE} derating factor changes the total continuous power dissipation (P_T) if the ambient temperature is not 70°C. Therefore for e.g. T_A=85°C calculate P_T at 85°C = P_T - P_{DERATE} × (85°C - 70°C)

3.2 Operating Conditions

3.2.1 General

Symbol	Parameter	Conditions	Min	Typ	Max	Unit
R _{thja}	Thermal resistance junction – ambient	See chapter "Thermal characteristics"				°C/W
T _{case}	Case Temperatur		-20		85	°C

Symbol	Parameter	Conditions	Min	Typ	Max	Unit
T _j	Junction Temperature		-20		115	°C

3.2.2 Power supply

Symbol	Parameter	Conditions	Min	Typ	Max	Unit
VDD	Supply Voltage		4.0		5.5	V
VDD_POR	Power on reset level	Circuit stays in power down until VDD_POR is reached. G1-G16 are pulled down with 130kΩ	2.4		2.9	V
IDD_q	Quiescent current	VDD= 5V, Default setting, PWM = 0		20		mA
IDD_r	Supply current	VDD = 5V, HSYNC = 1MHz, Duty = 50%		30		mA
V2_5	Voltage regulator output			2.5		V

3.2.3 Current outputs

Symbol	Parameter	Conditions	Min	Typ	Max	Unit
VDX	Output voltage pins Dx				30	V
RDX	Input resistance in Dx	PWM = 0 PWM = 1	10 0.1			MΩ MΩ
VGX	Max output voltage pin Gx	I _{gx} = 1mA			VDD-0.6	V
IGX	Max output current pin Gx			2	3	mA
IResx	Input current pin RESx	URESx = 0.5V URESx = 0.8V			10 100	µA
Iled_250	Trimmed Current accuracy	Trimmed during production ILED = 100mA, Temp = 25°C, DACref=800mV, VDAC = 250mV ⁽¹⁾ external NMOS-Transistor used, (excluding error of external Rset)	-0.5		+0.5	%
Iled_all_FET	Current accuracy External FET	Temp = 25°C, DACref=800mV, VDAC = 200mV to 800mV ⁽²⁾ external NMOS-Transistor used, (excluding error of external Rset)	-1.4		+1.4	%
Ich_250	Channel to channel Current accuracy	ILED = 100mA, Temp = 25°C, DACref=800mV, VDAC = 250mV ⁽¹⁾ external NMOS-Transistor used, (excluding error of external Rset)		0.2		%
Iled_all_T_FET	Current accuracy External FET	Tjunction = -20°C to +100°C, DACref=800mV, VDAC = 200mV to 800mV ⁽²⁾ external NMOS-Transistor used, (excluding error of external Rset)	-1.5		+1.5	%
Iled_all_T_BJT	Current accuracy External BJT (B=100)	Tjunction = -20°C to +100°C DACref=800mV, VDAC = 200mV to 800mV ⁽²⁾ external BJT-Transistor (B=100) used, (excluding error of external Rset)	-1.5		+1.5	%

Note: (1) It is recommended to use DACref = 800mV in order to achieve specified accuracy

(2) It is not recommended to use VDAC < 200mV in order to minimize influences from PCB- layout and noise.

3.2.4 Feedback circuit, fault detectors

Symbol	Parameter	Conditions	Min	Typ	Max	Unit
IFBmax	Feedback current maximum			200		µA
RFBmin	Minim output resistance	$V_{Dx} = 0.2V$		200	800	Ω
IFB_g	FB transconductance	$IFB_g = \Delta I_{FB} / \Delta V_{Dx}$		-2		mA/V
VFB	Feedback voltage trip point	Programmable Tolerance ±10%		0.6 0.8 1.0 VDAC +0.35		V
Vshort	Short LED detection voltage at Pin Dx	Programmable Tolerance ±1.2V		2		V
				3		V
				4		V
				5		V
				6		V
				7		V
				8		V
				9		V
				10		V
				11		V
				12		V
			Vopen	Open LED detection Voltage at Pin Sx	Programmable Tolerance ±10%	
Tovtemp	Over temperature limit		130	140	150	°C
Thyst	Over temperature hysteresis			10		°C

3.2.5 PWM-generators

Symbol	Parameter	Conditions	Min	Typ	Max	Unit
f _{osc}	Internal Clock for PWM		400	500	600	kHz
f _{HSYNC}	HSYNC frequency		100		2000	kHz
f _{VSYNC}	VSYNC frequency		60		480	Hz
f _{PLL}	PLL frequency		125		2000	kHz

3.2.6 Digital pins

Symbol	Parameter	Min	Typ	Max	Unit	Note
V _{IH}	High Level Input voltage	1.3		VDD	V	
V _{IL}	Low Level Input voltage	-0.3		0.8	V	
V _{oH}	High Level output voltage	VDD-0.3			V	I=mA
V _{oL}	Low Level output voltage			VDD-0.3	V	I=mA
V _{oL_PD}	Low level output voltage open drain outputs			VDD-0.3	V	I=mA
R _{pu}	Input resistance PullUp inputs		300		kΩ	

Symbol	Parameter	Min	Typ	Max	Unit	Note
R_pd	Input resistance PullDown inputs		300		kΩ	

3.2.7 SPI-timings

Symbol	Parameter	Min	Typ	Max	Unit	Note
f_sclk	SCLK frequency	0		10	MHz	
t1	xCS setup time	50			ns	
t2	xCS hold time	100			ns	
t3	xCS disable time	100			ns	
t4	SDI setup time	5			ns	
t5	SDI hold time	5			ns	
t6	SCLK rise time	5			ns	
t7	SCLK fall time	5			ns	
t8	SCLK low time	40			ns	
t9	SCLK high time	40			ns	
t10	output valid from SCLK low	10			ns	

SPI-input timing

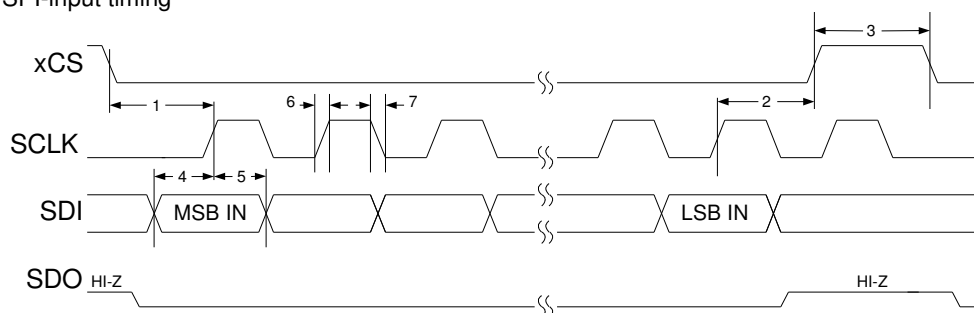

SPI-output timing

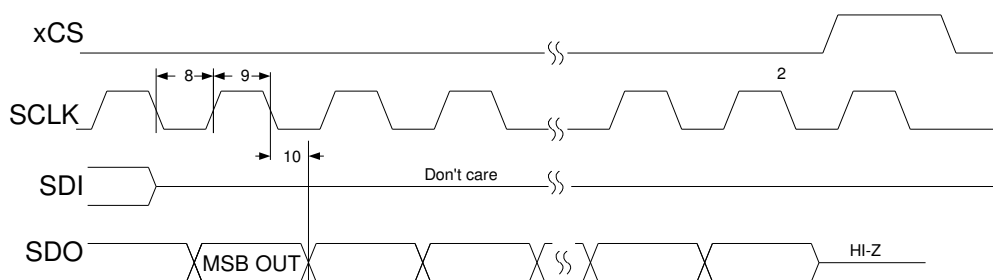

3.3 Pins equivalent circuit

VDD	
Digital inputs	
Digital inputs Pull up	
Digital inputs Pull Down	
Digital outputs push/pull	
Digital output open drain	

4 Detailed Block description

4.1 Current outputs

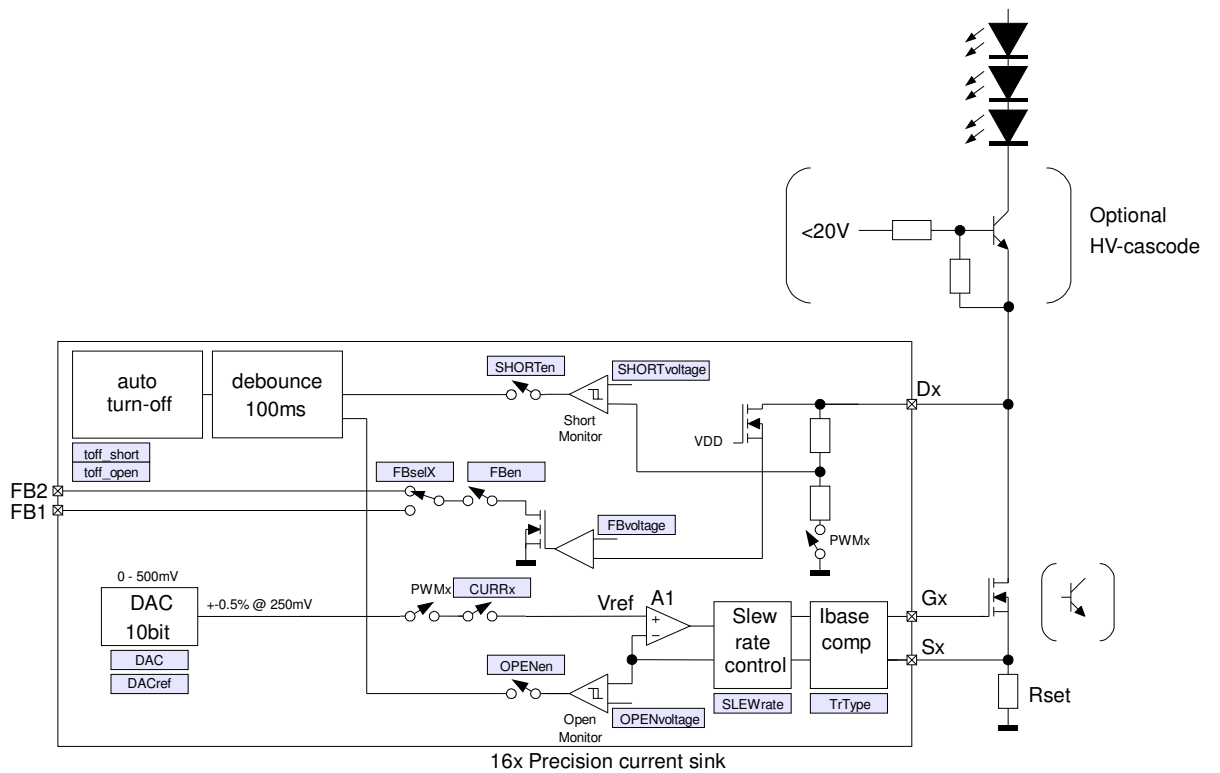

4.1.1 Precision current sink

All current sinks are built with an internal error amplifier A1 and an external power transistor. The external transistor can either be a NMOS or a NPN bipolar transistor. The driving current capability of the output amplifier is 2mA. For low EMI radiation the slew rate of the amplifier output voltage can be adjusted between 1us and 9us

4.1.2 Power supply feedback

The voltage on the pins “Dx” is monitored to adjust the DCDC output voltage. If this voltage is lower than “FBvoltage” a comparator turns on a NMOS transistor which is able to control the output voltage of the external power supply via pin FB1 or pin FB2. The feedback comparator can be assigned to either FB1 or FB2. The power supply feedback can be turned off for all channels by the flag “FBen”. If an output is turned off with the corresponding bit in the CUR_ON_1/2 -registers, the feedback function of this output is also automatically turned off.

4.1.3 Open LED detection

If a LED-string is broken the voltage at the current setting resistor goes below “OPENvoltage”. This status is detected by a comparator and if this status lasts longer than 100ms a fault is indicated and optionally the output and the corresponding power feedback function is turned off. This feature can also be used for external resistor short detection during production. For proper detection the PWM high time has to be longer than 50us.

4.1.4 Short LED detection

Shorted LEDs in a LED-string will cause higher voltage at pin “Dx”. A higher voltage during PWM=1 is detected by a comparator and will trigger a “short LED detection” fault. The duration of the fault is accumulated and if the time exceeds 100ms a fault is indicated and optionally the output is turned off. If the high-time of the waveform is shorter than 100ms it will take more periods to trigger this fault. For proper detection the PWM high time has to be longer than 50us.

4.1.5 Fault detection

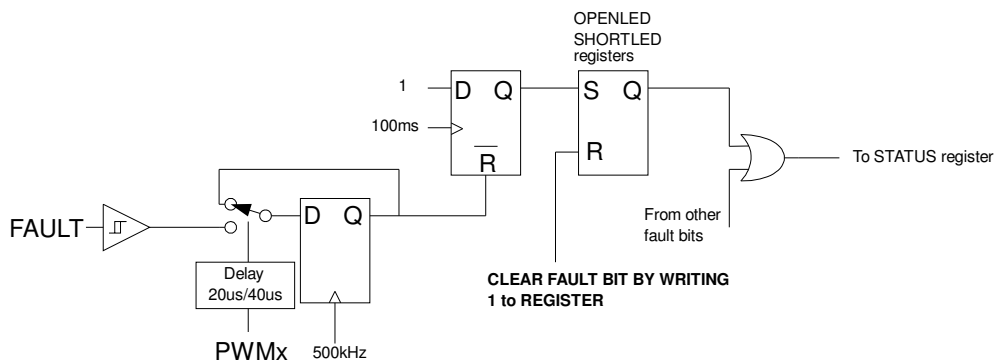

If an Open-LED or Short-LED condition is detected the fault-signal is debounced with an internal 100ms clock. This means that the fault will be indicated in the OPENLED or SHORTLED registers between 100ms and 200ms. In order to clear the bit in these registers a “1” has to be written.

4.1.6 DAC

The reference voltage for the output stage is generated by an internal 10-bit DAC. The DAC reference can be selected between 500mV and 800mV depending on register settings. The DAC is trimmed during production with DACref = 800mV to guarantee an output current accuracy of $\pm 0.5\%$ on every current output.

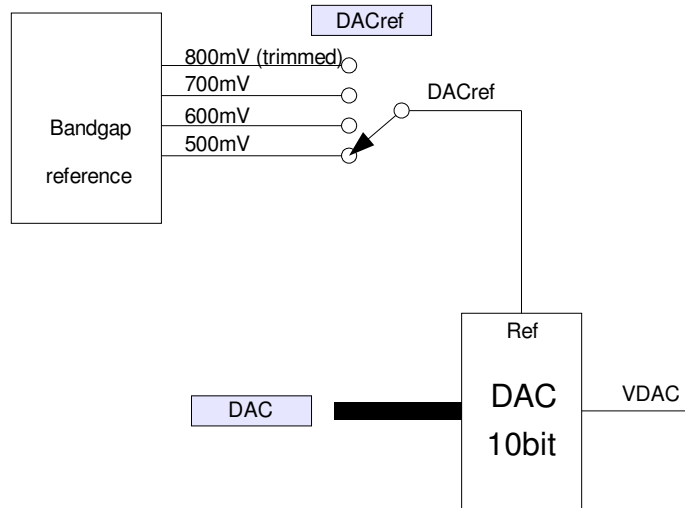

The DAC output voltage can be calculated with:

$$VDAC = \frac{DACref}{1024} * DAC$$

DAC...10bit data value

DACref...DAC reference voltage 500mV to 800mV

4.1.7 Registers in current output stage

RegAddr: 0x01		CUR_ON_1		
Bit	Name	Description	Default	Access
7:0	CURR1 - CURR8	Enables or disables current outputs 0...output OFF. Pulldown resistor to GND 1...output ON.	00000000	r/w

RegAddr: 0x02		CUR_ON_2		
Bit	Name	Description	Default	Access
7:0	CURR9 - CURR16	Enables or disables current outputs 0...output OFF. Pulldown resistor to GND 1...output ON.	00000000	r/w

RegAddr: 0x03		Fault_1		
Bit	Name	Description	Default	Access
7:3		Not used	00000	r/w
2	Toff_OverT	Automatic Output turn off at overtemperature 0...Do not turn off current outputs on overtemperature 1... Turn off current outputs on overtemperature	1	r/w
1	Toff_Short	Automatic Output turn off on short LED detection 0...Do not turn off current outputs on on short LED detection 1... Turn off current outputs on short LED detection	0	r/w
0	Toff_Open	Automatic Output turn off on open LED detection 0...Do not turn off current outputs on on open LED detection 1... Turn off current outputs on open LED detection	0	r/w

RegAddr: 0x04		Fault_2		
Bit	Name	Description	Default	Access
7:6	OPENvoltage	Trigger voltage for OPEN LED detection 00...50mV 01...100mV	00	r/w

		10...200mV 11...VDAC/2		
5:2	SHORTvoltage	Trigger voltage for SHORT LED detection 0000...2V 0001...3V 0010...4V 0011...5V 0100...6V 0101...7V 0110...8V 0111...9V 1000...10V 1001...11V 1010...12V 1011 to 1111 ...do not use	0000	r/w
1	SHORTen	Enable short LED detection 0...SHORT detection OFF 1...SHORT detection ON	0	r/w
0	OPENen	Enable open LED detection 0...OPEN detection OFF 1...OPEN detection ON	0	r/w

RegAddr: 0x05		Feedback		
Bit	Name	Description	Default	Access
7:6		Not used	00	r/w
5:4	FBvoltage	Feedback regulator trip voltage. This voltage has to be adjusted if current is larger than 70mA or VDAC is higher than 0.25V 00...0.6V 01...0.8V 10...1.0V 11...V-DAC + 0.35V	00	r/w
3	FBboost	Feedback boost option. FUNCTION DISABLED	0	r/w
2	TrType	Type of external transistor 0...external FET. Base current compensation is off 1...external BJT. Base current compensation is on.	0	r/w
1		Not used	0	r/w
0	FBen	Enable Feedback function for all current outputs. 1...Feedback function enabled 0...Feedback function disabled Note: If a current output is disabled its Feedback function is automatically disabled.	0	r/w

RegAddr: 0x06		FB_SEL1		
Bit	Name	Description	Default	Access
7:0	FBsel 1 - 8	Select FB-channel for current outputs 1 to 8 0...select FB channel FB1 1... select FB channel FB2	00000000	r/w

RegAddr: 0x07		FB_SEL2		
Bit	Name	Description	Default	Access
7:0	FBsel 9 - 16	Select FB-channel for current outputs 9 to 16 0...select FB channel FB1 1... select FB channel FB2	00000000	r/w

RegAddr: 0x08		CURRctrl		
Bit	Name	Description	Default	Access
7:6		Not used.	00	r/w
5:4	DACref	DAC reference voltage 00...500mV 01...600mV 10...700mV 11...800mV this reference is used at factory trimming	00	r/w
3:2		Not used	00	r/w
1:0	SLEWrate	Select slew rate of output drivers 00...9us 01...6us	00	r/w

		10...3us 11...1us		
--	--	----------------------	--	--

RegAddr: 0x09		SHORTLED1		
Bit	Name	Description	Default	Access
7:0	SHORTLED 1 - 8	Indicates short LED condition on outputs 1 to 8 0...no short LED detected 1... short LED detected	00000000	r/w

RegAddr: 0x0A		SHORTLED2		
Bit	Name	Description	Default	Access
7:0	SHORTLED 9 - 16	Indicates short LED condition on outputs 9 to 16 0...no short LED detected 1... short LED detected	00000000	r/w

RegAddr: 0x0B		OPENLED1		
Bit	Name	Description	Default	Access
7:0	OPENLED 1 - 8	Indicates open LED condition on outputs 1 to 8 0...no open LED detected 1... open LED detected	00000000	r/w

RegAddr: 0x0C		OPENLED2		
Bit	Name	Description	Default	Access
7:0	OPENLED 9 - 16	Indicates open LED condition on outputs 9 to 16 0...no open LED detected 1... open LED detected	00000000	r/w

RegAddr:		DAC		
0x0E	0x0D			
Bit	Bit	Description	Default	Access
1:0	7:0	DAC[9:0] defines DADC output voltage DACvoltage = DAC[9:0]* DACref/1024	100000000	r/w

4.2 PWM-generators

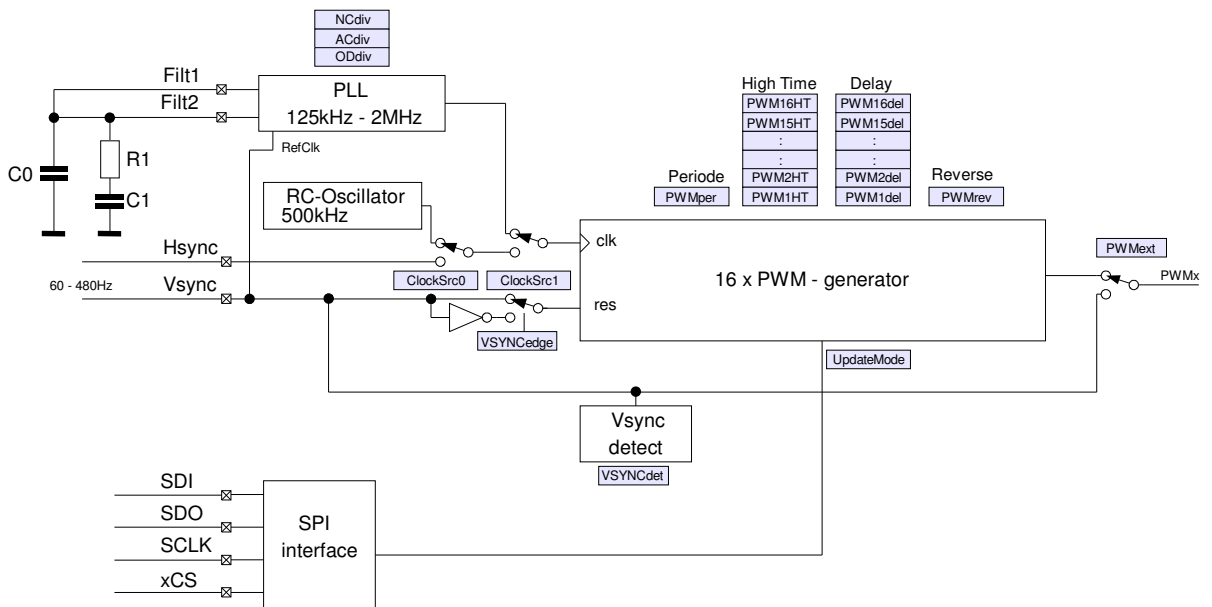

4.2.1 Clock and reset

The clock for the built in PWM-generators can be one of three different sources.

1. Internal RC oscillator with 500KHz +/-20%

2. External Clock signal. This is usually the HSYNC signal of the TV.
3. Internal clock signal that is synchronized to the external VSYNC signal by means of a PLL

The VSYNC input can be used as reference clock for the PLL and also as reset signal for all PWM-generators.

4.2.2 PWM-counter

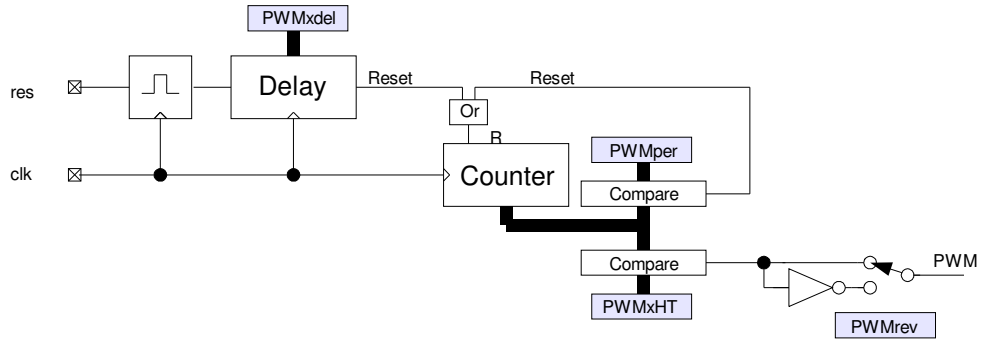

Each PWM-generator is build with a 12bit counter and digital comparators. The counter is counting up with t_{clk} until the value stored in "PWMper" is reached. This resets the counter and starts the next period. While the counter value is below "PWMxHT" the PWM-signal is "1", the rest of the period the PWM-signal is "0". The output of each PWM-generator can also be inverted by means of the "PWMrev".

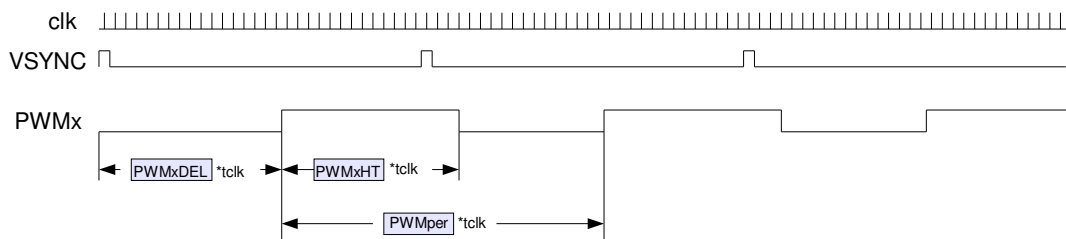

4.2.3 SPI data update, UPDATEmode bit

The PWM-settings that are programmed via the SPI-Interface take effect depending on the status of the "UPDATEmode"-bit.

If UPDATEmode =1 new data from the serial interface are stored at the next rising edge of VSYNC
 If UPDATEmode =0 new data from the serial interface are stored immediately after xCS goes high and will take effect after current PWM cylice is finished. In this mode the values in the PWMxdel registers are ignored. There will be no Delay on the PWM signals.

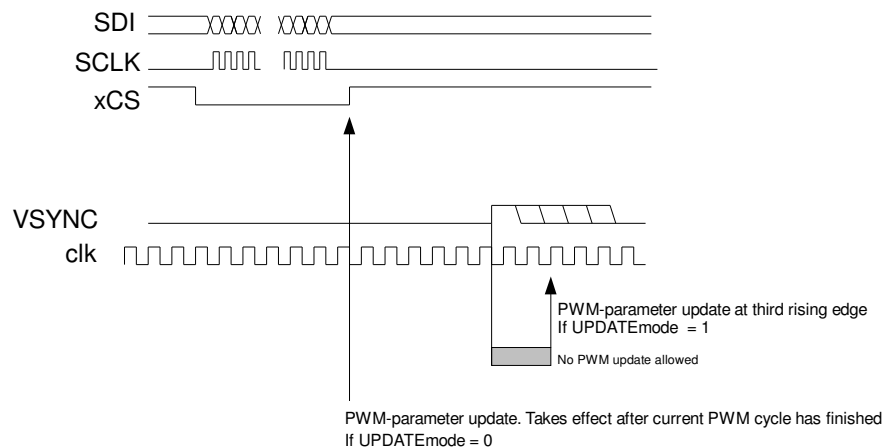

The PWMxHT-values are double buffered. HighTime values for the next VSYNC can be written even when the current HighTime is not finished.

4.2.4 PWM direct control

The internal signals PWMx can also be direct applied at the VSYNC input if the bit PWMext=1.

4.2.5 VSYNC detect

The VSYNCdet=1 the VSYNC detector monitors the presence of a VSYNC signal. If the VSYNC signal is missing for more than 100ms current outputs are temporary turned off.

4.2.6 VSYNC duration

Since the VSYNC input is connected to an edge detector, there is no restriction on the duration of the VSYNC pulse.

4.2.7 PLL

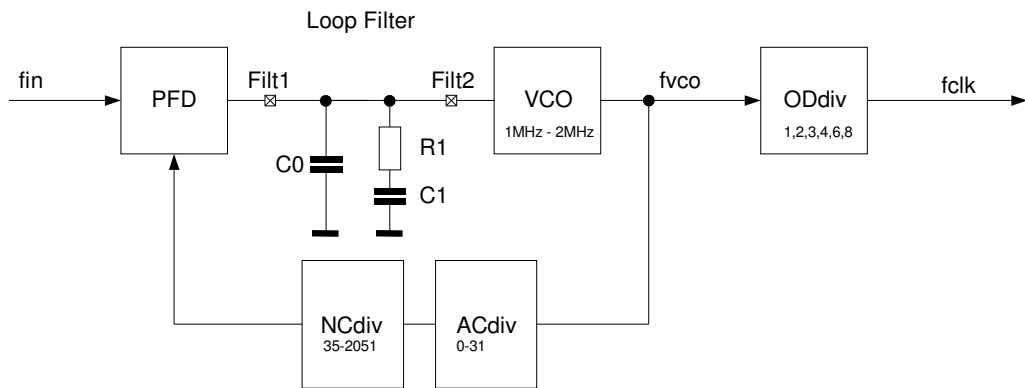

The PLL frequency synthesizer can be used to generate PWM-clock frequencies f_{clk} between 125kHz and 2MHz derived from input frequencies between 60Hz and 480Hz.

The VCO frequency can be calculated:

$$f_{VCO} = f_{IN}((NCdiv + 4) * 32 + ACdiv)$$

The output frequency can be calculated:

$$f_{CLK} = f_{IN}((NCdiv + 4) * 32 + ACdiv) / ODdiv$$

where:

		Range
f_{in}	Input frequency	60 Hz – 480Hz
f_{clk}	Output frequency	125kHz – 2MHz
f_{VCO}	VCO frequency	1MHz – 2MHz
NCdiv	counter	35 - 2051
ACdiv	counter	0 - 31
ODdiv	Output divider	1,2,3,4,6,8

The main blocks of the PLL are the Phase-Frequency-Detector, the Loop Filter, the VCO and the divider.

4.2.7.1 Phase-Frequency-Detector (PFD)

The block diagram of the phase-frequency-comparator is shown below. The output signal on pin "Filt1" is a switched current source (ICP) which is sinking or sourcing current depending of the frequency and phase difference of f_{in} and f_{VCO}/M .

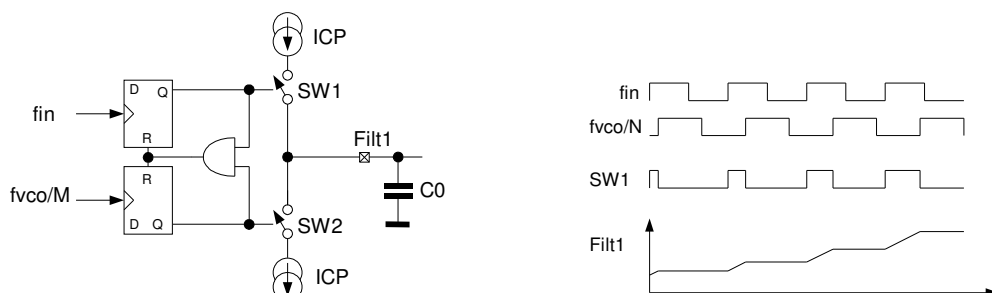

4.2.7.2 VCO

In VCO has an operating range between 1MHz and 2MHz. If lower clock frequencies are required the output divider (ODdiv) has to be used.

4.2.7.3 Loop filter

The output of the PFD charges a loop filter which is controlling the output frequency of the VCO. The loop filter determines the speed of the frequency lock and the remaining phase noise of the VCO output frequency.

Example of a loop filter:

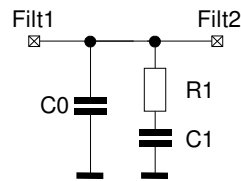

Calculation process for loop filter:

Terms: f_{VCO} ...Desired f_{VCO} frequency
 f_{IN} ...Reference input frequency

I_{cp} ...PFC output current 0.5uA
 K_{VCO} ...VCO sensitivity 2.5MHz/V

1. Determined dividing ratio:
$$M = \frac{f_{VCO}}{f_{IN}}$$
2. Calculate Bandwidth BW:
$$BW = \frac{f_{in}}{10}$$
3. Calculate C1:
$$C_1 = \frac{I_{cp} * K_{VCO}}{M * (\frac{\pi * BW}{1.1})^2}$$
4. Calculate R1:
$$R_1 = \frac{1.4 * \tan(65^\circ)}{2 * \pi * BW * C_1}$$
5. Calculate C0:
$$C_0 = \frac{C_1}{10}$$

4.2.7.4 Calculation Examples:

Vsync [Hz]	Resolution [bit]	Fclk [Hz]	Reg 0x61	Reg 0x62	Reg 0x63	C0 [nF]	R1 [kΩ]	C1 [nF]
50	12	204800	0xFC	0x03	0x05	18,7	510	187
60	12	245760	0xFC	0x02	0x04	17,3	459	173
100	11	204800	0xFC	0x01	0x05	9,3	510	93
100	12	409600	0xFC	0x01	0x03	9,3	510	93
120	10	122880	0xFC	0x00	0x05	13,0	306	130
120	11	245760	0x7C	0x01	0x04	8,7	459	87
120	12	491520	0x7C	0x01	0x02	8,7	459	87
200	10	204800	0xFC	0x00	0x05	4,7	510	47
200	11	409600	0xFC	0x00	0x03	4,7	510	47
200	12	819200	0xFC	0x00	0x01	4,7	510	47
240	10	245760	0xBC	0x00	0x04	4,3	459	43
240	11	491520	0xBC	0x00	0x02	4,3	459	43
240	12	983040	0xFC	0x00	0x01	3,2	612	32
400	10	409600	0x7C	0x00	0x03	2,3	510	23
400	11	819200	0x7C	0x00	0x01	2,3	510	23
400	12	1638400	0x7C	0x00	0x00	2,3	510	23
480	10	491520	0x5C	0x00	0x02	2,2	459	22
480	11	983040	0x7C	0x00	0x01	1,6	612	16
480	12	1966080	0x7C	0x00	0x00	1,6	612	16

4.2.8 Registers in PWM-generators

RegAddr: 0x11		PWMREV1		
Bit	Name	Description	Default	Access
7:0	PWMrev 1 - 8	Selects PWM inverted operation for outputs 1 to 8 0...PWM normal 1... PWM inverted	00000000	r/w

RegAddr: 0x12		PWMREV2		
Bit	Name	Description	Default	Access
7:0	PWMrev 9 - 16	Selects PWM inverted operation for outputs 9 to 16 0...PWM normal 1... PWM inverted	00000000	r/w

RegAddr: 0x13		PWMCTRL		
Bit	Name	Description	Default	Access
7	FaultDetDly	Sets delay time between PWM=1 and fault detection start 0...120us 1...60us	0	r/w
6	DelayStart	Defines when new PWM-Delay value takes effect 0...Delay values are updated every VSYNC pulse 1...Delay values are updated on the next VSYNC pulse only if HighTime or Delay value has been changed.	0	r/w
5	ClockSrc1	Clock source for internal PWM-generators 0..internal RC oscillator or HSYNC (depending on ClockSrc0) 1...PLL output	0	r/w
4	VSYNCdet	Enable VSYNC detection 0...VSYNC-detection OFF 1... VSYNC-detection ON. All current outpts are turned off if VSYNC signal is missing for 100ms	0	r/w
3	VSYNCedge	Defines VSYNC trigger edge 0...VSYNC trigger on rising edge 1...VSYNC trigger on falling edge	0	r/w
2	PWMext	Select external or internal PWM signal 0...PWM signal is generated internally 1...PWM signal is applied externally at pin VSYNC	0	r/w
1	UpdateMode	Defines when internal registers are updated 0...Registers updated with rising edge of xCS 1...Registers updated with next VSYNC-edge	0	r/w
0	ClockSrc0	Clock source for internal PWM-generators 0..internal RC oscillator 1...External Pin HSYNC Note: This bit only takes effect when ClockSrc1 = 0	0	r/w

RegAddr:		PWMperiod		
0x15	0x14			
Bit	Bit	Description	Default	Access
3:0	7:0	PWMper[11:0] sets PWM period	0x00, 0x00	r/w

RegAddr:		PWM1delay		
0x17	0x16			
Bit	Bit	Description	Default	Access
3:0	7:0	PWM1del[11:0] sets PWM1 delay	0x00, 0x00	r/w

RegAddr:		PWM2delay		
0x19	0x18			
Bit	Bit	Description	Default	Access
3:0	7:0	PWM2del[11:0] sets PWM2 delay	0x00, 0x00	r/w

RegAddr:		PWM3delay		
0x1B	0x1A			

Bit	Bit	Description	Default	Access
3:0	7:0	PWM3del[11:0] sets PWM3 delay	0x00, 0x00	r/w

RegAddr:		PWM4delay		
0x1D	0x1C			
Bit	Bit	Description	Default	Access
3:0	7:0	PWM4del[11:0] sets PWM4 delay	0x00, 0x00	r/w

RegAddr:		PWM5delay		
0x1F	0x1E			
Bit	Bit	Description	Default	Access
3:0	7:0	PWM5del[11:0] sets PWM5 delay	0x00, 0x00	r/w

RegAddr:		PWM6delay		
0x21	0x20			
Bit	Bit	Description	Default	Access
3:0	7:0	PWM6del[11:0] sets PWM6 delay	0x00, 0x00	r/w

RegAddr:		PWM7delay		
0x23	0x22			
Bit	Bit	Description	Default	Access
3:0	7:0	PWM7del[11:0] sets PWM7 delay	0x00, 0x00	r/w

RegAddr:		PWM8delay		
0x25	0x24			
Bit	Bit	Description	Default	Access
3:0	7:0	PWM8del[11:0] sets PWM8 delay	0x00, 0x00	r/w

RegAddr:		PWM9delay		
0x27	0x26			
Bit	Bit	Description	Default	Access
3:0	7:0	PWM9del[11:0] sets PWM9 delay	0x00, 0x00	r/w

RegAddr:		PWM10delay		
0x29	0x28			
Bit	Bit	Description	Default	Access
3:0	7:0	PWM10del[11:0] sets PWM10 delay	0x00, 0x00	r/w

RegAddr:		PWM11delay		
0x2B	0x2A			
Bit	Bit	Description	Default	Access
3:0	7:0	PWM11del[11:0] sets PWM11 delay	0x00, 0x00	r/w

RegAddr:		PWM12delay		
0x2D	0x2C			
Bit	Bit	Description	Default	Access
3:0	7:0	PWM12del[11:0] sets PWM12 delay	0x00, 0x00	r/w

RegAddr:		PWM13delay		
0x2F	0x2E			
Bit	Bit	Description	Default	Access
3:0	7:0	PWM13del[11:0] sets PWM13 delay	0x00, 0x00	r/w

RegAddr:		PWM14delay		
0x31	0x30			
Bit	Bit	Description	Default	Access
3:0	7:0	PWM14del[11:0] sets PWM14 delay	0x00, 0x00	r/w

RegAddr:		PWM15delay		
0x33	0x32			
Bit	Bit	Description	Default	Access
3:0	7:0	PWM15del[11:0] sets PWM15 delay	0x00, 0x00	r/w

RegAddr:		PWM16delay		
0x35	0x34			
Bit	Bit	Description	Default	Access
3:0	7:0	PWM16del[11:0] sets PWM16 delay	0x00, 0x00	r/w

RegAddr: 0x36		LOCKUNLOCK		
Bit	Name	Description	Default	Access
7:0	LOCKUNLOCK	<p>MagicByte to lock and unlock writing and reading of registers</p> <p>Writing into register: 0xCX...unlock register Group1. Writing enabled 0xA...unlock register Group2. Writing enabled 0xCA...unlock register Group1 and Group2. Writing enabled</p> <p>0xAC...lock register Group1. Writing disabled 0xC...lock register Group2. Writing disabled 0x0...lock register Group1 and Group2. Writing disabled</p> <p>X...don't care. All other values do not change the status of lockunlock.</p> <p>Reading from register: 0x00.... Group1 and Group2 are locked 0x01...Group1 is unlocked 0x02...Group2 is unlocked 0x03...Group1 and Group2 are unlocked</p>	0x00	r/w

RegAddr:		PWM1hightime		
0x38	0x37			
Bit	Bit	Description	Default	Access
3:0	7:0	PWM1HT[11:0] sets PWM1 high time	0x00, 0x00	r/w

RegAddr:		PWM2hightime		
0x3A	0x39			
Bit	Bit	Description	Default	Access
3:0	7:0	PWM2HT[11:0] sets PWM2 high time	0x00, 0x00	r/w

RegAddr:		PWM3hightime		
0x3C	0x3B			
Bit	Bit	Description	Default	Access
3:0	7:0	PWM3HT[11:0] sets PWM3 high time	0x00, 0x00	r/w

RegAddr:		PWM4hightime		
0x3E	0x3D			
Bit	Bit	Description	Default	Access
3:0	7:0	PWM4HT[11:0] sets PWM4 high time	0x00, 0x00	r/w

RegAddr:		PWM5hightime		
0x40	0x3F			
Bit	Bit	Description	Default	Access
3:0	7:0	PWM5HT[11:0] sets PWM5 high time	0x00, 0x00	r/w

RegAddr:		PWM6hightime		
0x42	0x41			
Bit	Bit	Description	Default	Access
3:0	7:0	PWM6HT[11:0] sets PWM6 high time	0x00, 0x00	r/w

RegAddr:		PWM7hightime		
0x44	0x43			
Bit	Bit	Description	Default	Access
3:0	7:0	PWM7HT[11:0] sets PWM7 high time	0x00, 0x00	r/w

RegAddr:		PWM8hightime		
0x46	0x45			
Bit	Bit	Description	Default	Access
3:0	7:0	PWM8HT[11:0] sets PWM8 high time	0x00, 0x00	r/w

RegAddr:		PWM9hightime		
0x48	0x47			
Bit	Bit	Description	Default	Access
3:0	7:0	PWM9HT[11:0] sets PWM9 high time	0x00, 0x00	r/w

RegAddr:		PWM10hightime		
0x4A	0x49			
Bit	Bit	Description	Default	Access
3:0	7:0	PWM10HT[11:0] sets PWM10 high time	0x00, 0x00	r/w

RegAddr:		PWM11hightime		
0x4C	0x4B			
Bit	Bit	Description	Default	Access
3:0	7:0	PWM11HT[11:0] sets PWM11 high time	0x00, 0x00	r/w

RegAddr:		PWM12hightime		
0x4E	0x4D			
Bit	Bit	Description	Default	Access
3:0	7:0	PWMHT12[11:0] sets PWM12 high time	0x00, 0x00	r/w

RegAddr:		PWM13hightime		
0x50	0x4F			
Bit	Bit	Description	Default	Access
3:0	7:0	PWM13HT[11:0] sets PWM13 high time	0x00, 0x00	r/w

RegAddr:		PWM14hightime		
0x52	0x51			
Bit	Bit	Description	Default	Access
3:0	7:0	PWM14HT[11:0] sets PWM14 high time	0x00, 0x00	r/w

RegAddr:		PWM15hightime		
0x54	0x53			
Bit	Bit	Description	Default	Access
3:0	7:0	PWM15HT[11:0] sets PWM15 high time	0x00, 0x00	r/w

RegAddr:		PWM16hightime		
0x56	0x55			
Bit	Bit	Description	Default	Access
3:0	7:0	PWM16HT[11:0] sets PWM16 high time	0x00, 0x00	r/w

RegAddr: 0x61		PLLctrl1		
Bit	Name	Description	Default	Access
7:0	NCdiv[7:0]	PLL divider NCdiv low bits 0 - 7	00000000	r/w

RegAddr: 0x62		PLLctrl2		
Bit	Name	Description	Default	Access
7:3	ACdiv[4:0]	PLL divider ACdiv	00000	r/w
2:0	NCdiv[10:8]	PLL divider NCdiv high bits 8 - 10	000	r/w

RegAddr: 0x63		PLLctrl3		
Bit	Name	Description	Default	Access
7:6			00	r
5:3	ICP[2:0]	PLL charge pump output current Icp 000...0.5uA 001...1uA 010...2uA 011...4uA 100...8uA 101...8uA 110...8uA 111...8uA	000	r/w
2:0	ODdiv[2:0]	PLL divider ODdiv 000...div 1 001...div 2 010...div 3 011...div 4 100...div 6 101...div 8 110...div 8 111...div 8	000	r/w

4.2.9 PWM examples

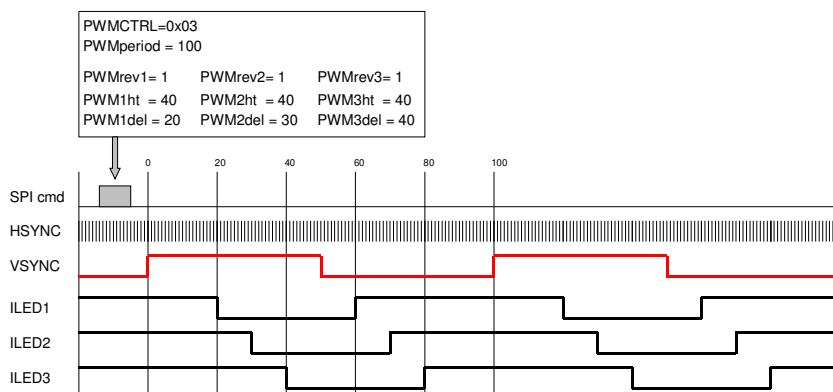
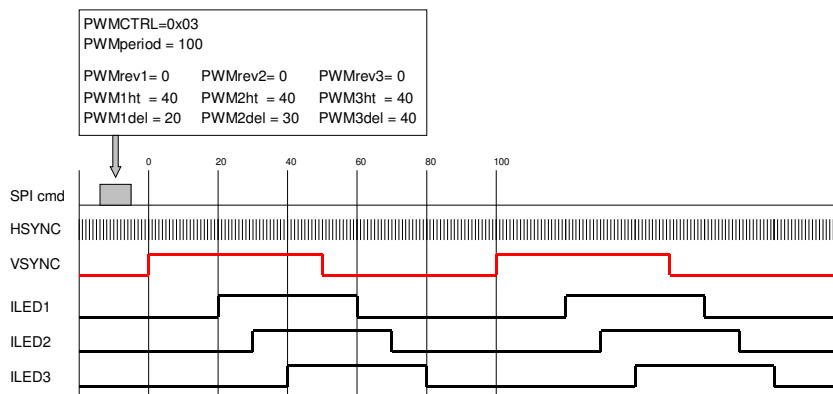

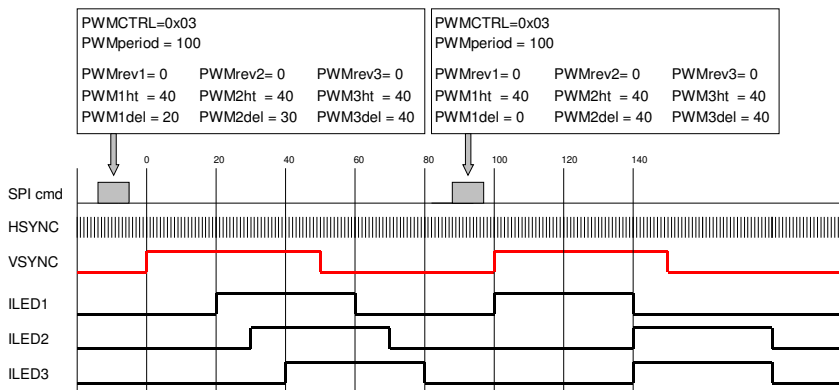
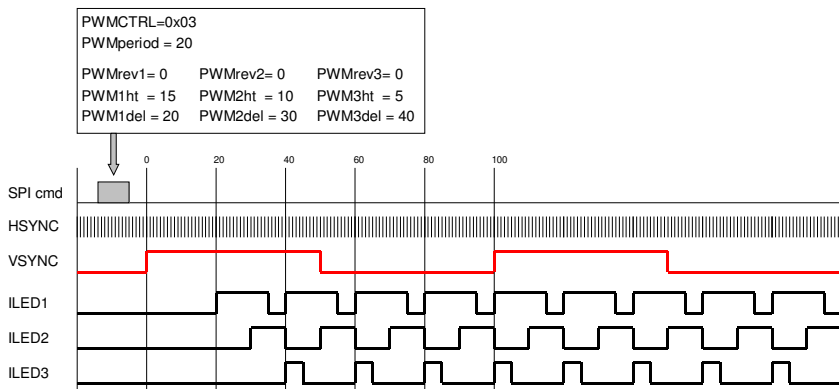
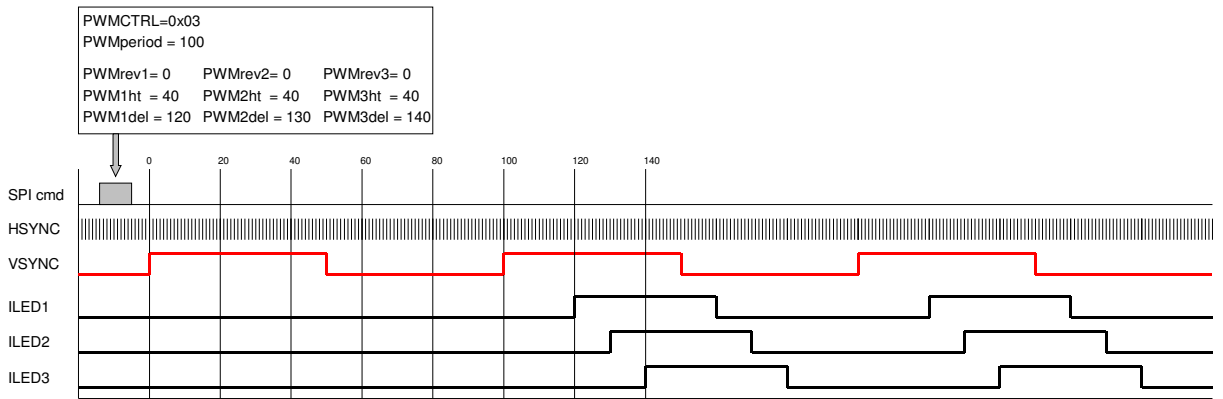

4.3 Power supply

4.4 Safety features

4.4.1 Temperature shutdown

If OTturnoff = 1 the outputs of the device are turned off when the die temperature reaches 140°C. If the die temperature goes below 130°C the outputs are turned on again.

4.4.2 xRES input

In addition to the build in power on reset circuit there is an external reset input "xRES" available. This gives the possibility to keep the outputs turned off until all blocks of the LED-driver circuits are fully working (DCDC, MCU ...)

4.4.3 Register Lock/Unlock

To prevent wrong writing to registers due to noise on the serial interface a lock/unlock mechanism is implemented.

Register 0x01, 0x02, 0x03, 0x04, 0x05, 0x06, 0x07, 0x08, 0x13 , 0x61, 0x62, 0x63 belong to Group1 and can only be written if Group1 is unlocked by the "LOCKUNLOCK"-byte (Reg: 0x36)

Register 0x0D, 0x0E, 0x11, 0x12, 0x14, 0x15 belong to Group2 and can only be written if Group2 is unlocked by the "LOCKUNLOCK"-byte (Reg: 0x36)

The default value of the Groups is locked.

4.5 Reference circuit

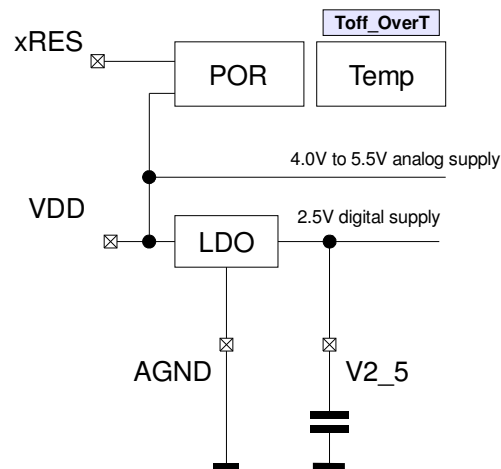

The reference circuit generates an internal supply voltage of 2.5V for the digital logic.

RegAddr: 0x58		STATUS		
Bit	Name	Description	Default	Access
7	STATnosync	Sync detector status 0...no sync fault 1...sync fault. VSYNC was missed for > 100ms	0	r
6	STATOT	Overtemperature status 0...no overtemperature 1...overtemperature	0	r
5	STATopen	Status open LED detection 0...no open LED detected 1...opdn LED detected	0	r
4	STATshort	Status short LED detection 0...no short LED detected 1...short LED detected	0	r
3		Not used	0	

2	STATUVLO	Status under voltage lockout detector 0...supply OK 1...supply voltage is to low	0	R
1:0	STATpower	Status of power supply monitor 00...no power supply 01...power supply is ramping up 10...power supply good 11...not used	10	r

4.6 Dynamic feedback control

The output of pins “FB1” and “FB2” can be used to control any external power supply for best power efficiency. Every power supply senses its output voltage with a resistive voltage divider. This voltage divider can be modified to set the output voltage between a minimum output voltage VMIN and a maximum output voltage VMAX. The design of the dynamic feedback control is done in 3 steps.

Step 1: Set the resistors R1,R2 in the power supply according to the minimum output voltage

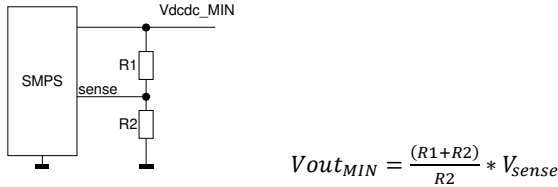

Step 2: Add the Resistors R3 in the power supply according to the maximum output voltage

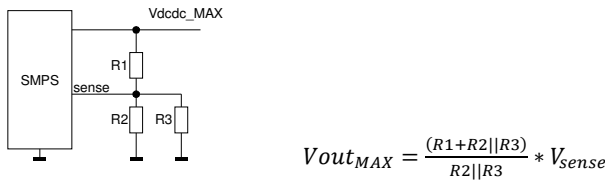

Step 3: Connect R3 to the feedback pin “FB”. C1 should be chosen according to the speed requirements of the feedback loop.

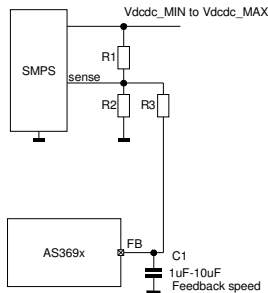

The characteristic of the feedback function can be seen in the following diagram. The final output voltage Vdcdc is determined by the setting of “FBvoltage” and the current flowing into the FB pin.

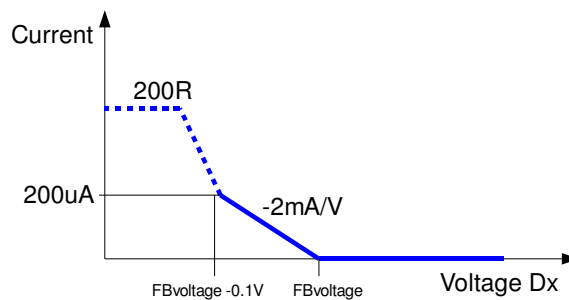

5 SPI interface

For the data transfer a serial peripheral interface (SPI) is used. The SPI is configured to work only as SPI slave. If more than one driver is connected to a SPI master, they can be connected in a “Daisy Chain”-structure or a parallel structure.

5.1 SPI daisy-chain structure

All SPI slaves share the same clock (SCLK) and chip select (xCS) signal. In that configuration all devices can be treated as one big shift register. The devices are automatically enumerated as described in the next section.

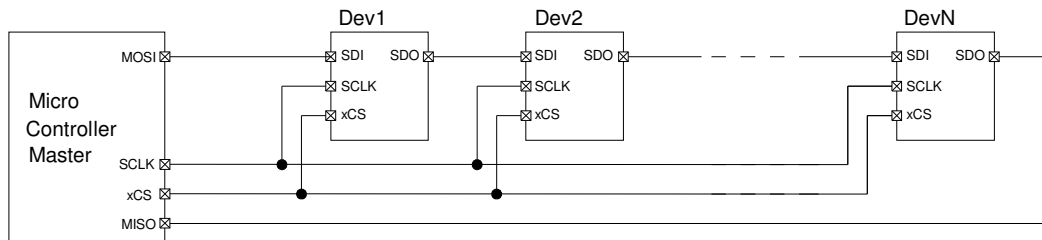

5.2 SPI parallel structure

All SPI slaves share the same input (SDI) output (SDO) and clock (SCLK) signal. Every single device can be addressed via the chip select (xCS) signal. In this configuration every device has $DevAddr = 0x01$.

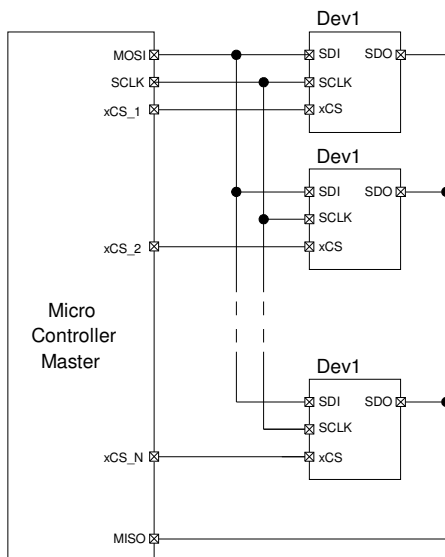

5.3 SPI device address enumeration

The device address of each driver is automatically set by the position of the device in the chain. The first device has $DevAddr = 0x01$, the second device has $DevAddr = 0x02$ and so on. Device Addresses $0x00$ and $0x3F$ are used for special broadcast writing commands described below.

5.4 SPI protocol

5.4.1 Data types

When xCS=0 all slaves will be activated. The addressing and data section is organized in byte packages. Each message can be built with the following Bytes:

Device address:

B	S	DevAddr[5:0]
---	---	--------------

Addresses a specific driver and defines protocol information

Bit	Meaning	Value
B	Broadcast	B=1...Broadcast message to all devices B=0...Normal message to one single device
S	Singlebyte	S=0...Block data read or write S=1...Single data transmission (only one byte)
DevAddr[5:0]	Device Address	0x00 Write same data to same register of all devices (B=1) 0x01 to 0x3E. Device addresses for device 1 to 62 0x3F Write different data to same register of all devices (B=1)

Nr_of_data:

NrOfdata[7:0]

Defines the number of data bytes in the data frame if S=0

Bit	Meaning	Value
NrOfdata[7:0]	Number of data bytes in frame	0x00 to 0xFF

Register_address:

RW	RegAddr[6:0]
----	--------------

Register address to be read or written

Bit	Meaning	Value
RW	Read/xWrite	RW=0 write to reg address RW=1 read from reg address
RegAddr[6:0]	Select register address	0x00 to 0x60

Data:

data[7:0]

Data

Bit	Meaning	Value
data [7:0],	Data	0x00 to 0xFF

5.4.2 Timings

Write single data into single device

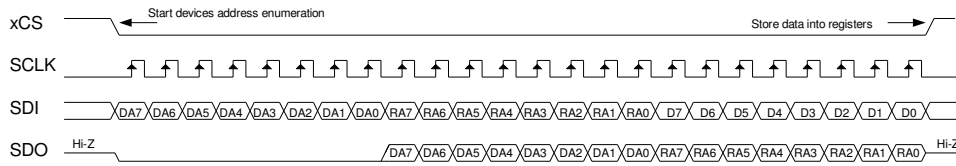

Read single data from single device

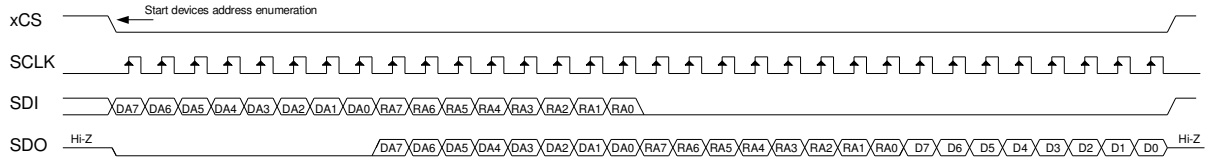

DA...DevAddr
RA...RegAddr
D.....Data

5.5 SPI protocol examples

5.5.1 Write single data

Write to Reg0x02 of Dev0x01

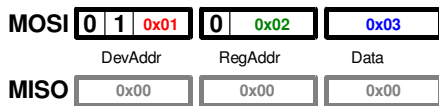
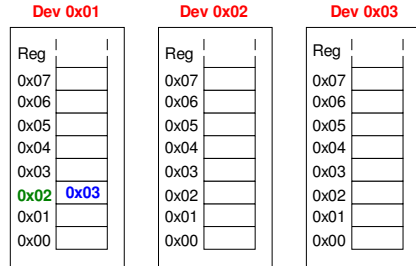

Write to Reg0x02 of Dev0x03

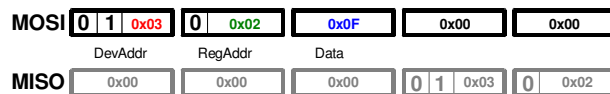
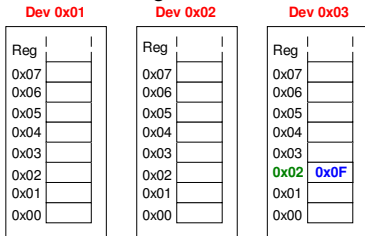

5.5.2 Write N data

Write to Reg0x02 - Reg0x04 of Dev0x01

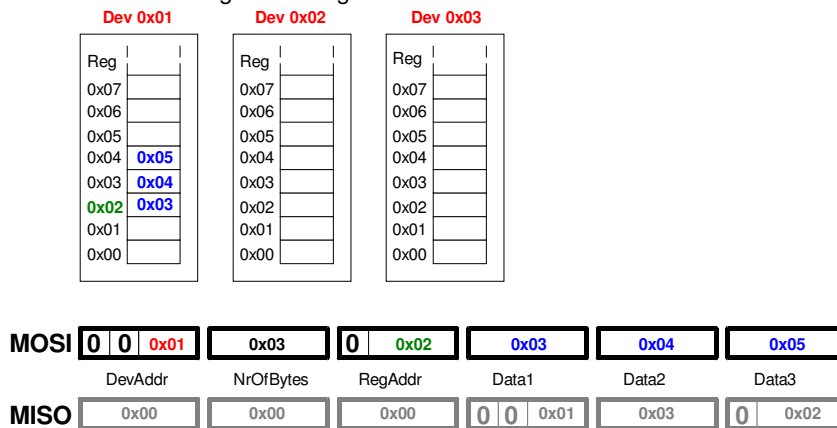

5.5.3 Write different data in same register of all devices (single byte)

Set DevAdd = 0x3F

Write to Reg0x02 of Dev0x01 – Dev0x03

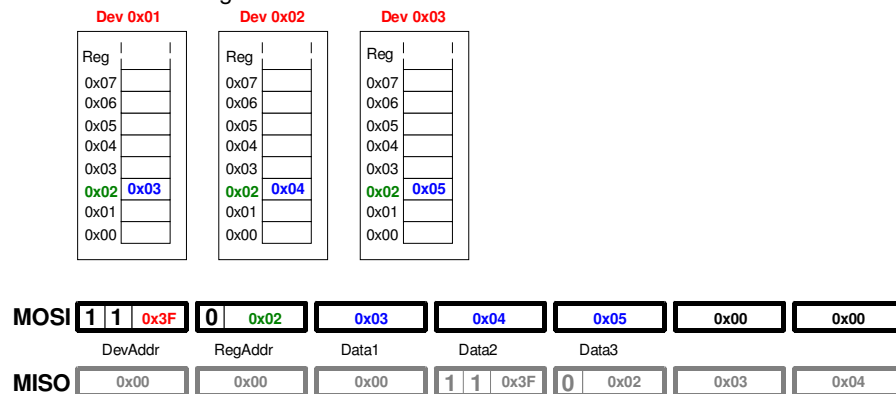

5.5.4 Write different data in same register of all devices (multiple bytes)

Set DevAdd = 0x3F

Write to Reg0x02- Reg0x03 of Dev0x01 – Dev0x03

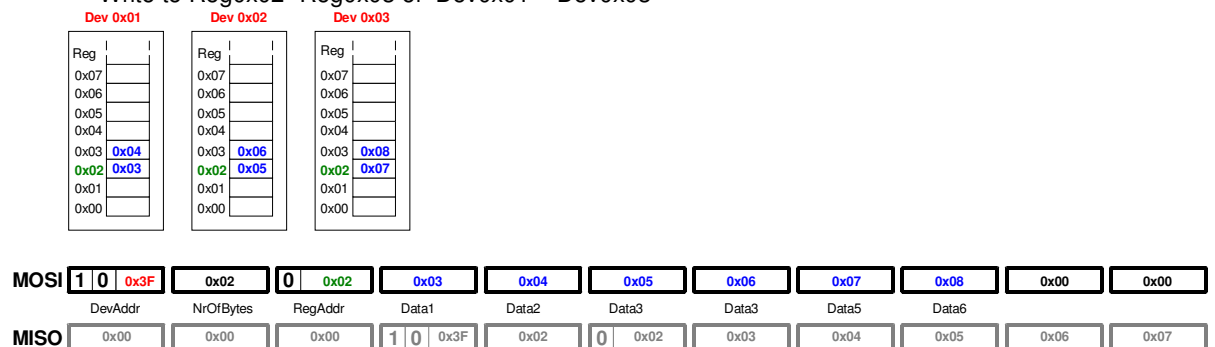

5.5.5 Write same data in same register of all devices (single byte)

Set DevAdd = 0x00

Write to Reg0x02 of Dev0x01 – Dev0x03

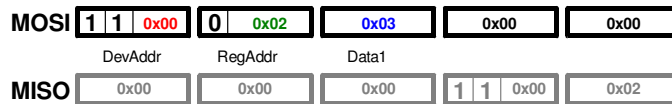
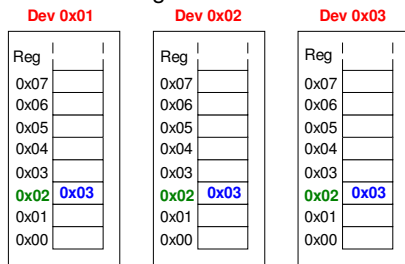

5.5.6 Write same data in same register of all devices (multiple bytes)

Set DevAdd = 0x00

Write to Reg0x02 - Reg0x04 of Dev0x01 – Dev0x03

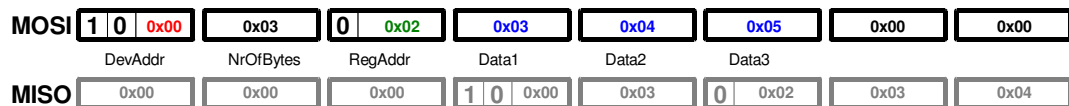
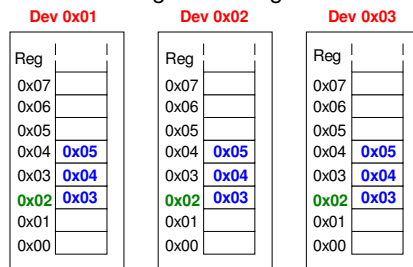

5.5.7 Read single data

Read from Reg0x02 of Dev0x01

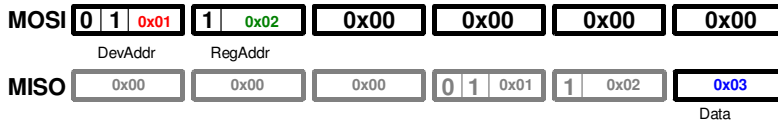
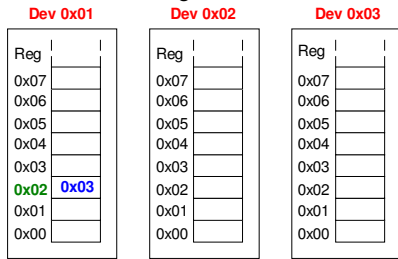

Read from Reg0x02 of Dev0x03

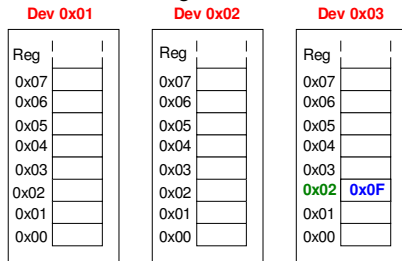

5.5.8 Read N data

Read from Reg0x02-Reg0x04 of Dev0x03

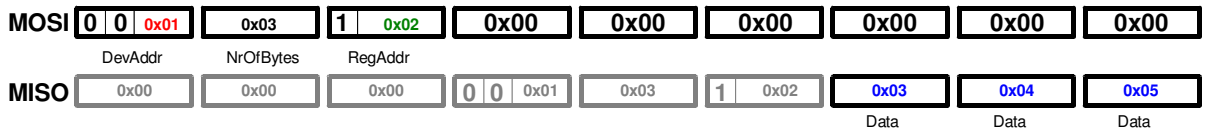
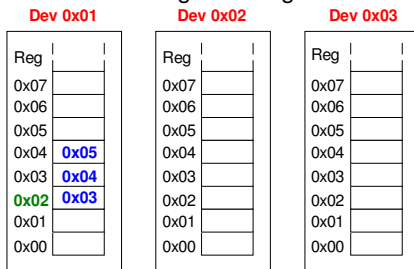

6 Register map

Registers can only be written if Group1 is UNLOCKED. Default = LOCKED
Registers can only be written if Group2 is UNLOCKED. Default = LOCKED

Addr	Name	D7	D6	D5	D4	D3	D2	D1	D0	Def ault	
0x00		Used for block writing									
0x01	CUR_ON_1	Curr8	Curr7	Curr6	Curr5	Curr4	Curr3	Curr2	Curr1	0x00	
0x02	CUR_ON_2	Curr16	Curr15	Curr14	Curr13	Curr12	Curr11	Curr10	Curr9	0x00	
0x03	FAULT_1						Toff Otemp	Toff short	Toff open		0x04
0x04	FAULT_2	OPEN voltage			SHORT voltage			SHORT en	OPEN en		0x00
0x05	FEEDBACK				FB voltage		FB boost	Tr Type		FB enable	0x00
0x06	FB_SEL1	FBsel8	FBsel7	FBsel6	FBsel5	FBsel4	FBsel3	FBsel2	FBsel1	0x00	
0x07	FB_SEL2	FBsel16	FBsel15	FBsel14	FBsel13	FBsel12	FBsel11	FBsel10	FBsel9	0x00	
0x08	CURRctrl	DAC ref					Slew rate				0x00
0x09	SHORTLED1	Short8	Short7	Short6	Short5	Short4	Short3	Short2	Short1	0x00	
0x0A	SHORTLED2	Short16	Short15	Short14	Short13	Short12	Short11	Short10	Short9	0x00	
0x0B	OPENLED1	Open8	Open7	Open6	Open5	Open4	Open3	Open2	Open1	0x00	
0x0C	OPENLED2	Open16	Open15	Open14	Open13	Open12	Open11	Open10	Open9	0x00	
0x0D	DACLSB	DAC7	DAC6	DAC5	DAC4	DAC3	DAC2	DAC1	DAC0	0x00	
0x0E	DACMSB								DAC9	DAC8	0x20
0x0F											
0x10											
0x11	PWMREV1	PWM Rev8	PWM Rev7	PWM Rev6	PWM Rev5	PWM Rev4	PWM Rev3	PWM Rev2	PWM Rev1	0x00	
0x12	PWMREV2	PWM Rev16	PWM Rev15	PWM Rev14	PWM Rev13	PWM Rev12	PWM Rev11	PWM Rev10	PWM Rev9	0x00	
0x13	PWMCTRL	Fault DetDly	Delay Start	Clock Src1	VSYNC det	VSYNC edge	PWM ext	Update Mode	Clock Src0	0x00	
0x14	PWMperiodLSB	PWM Per7	PWM Per6	PWM Per5	PWM Per4	PWM Per3	PWM Per2	PWM Per1	PWM Per0	0x00	
0x15	PWMperiodMSB	0	0	0	0	PWM Per11	PWM Per10	PWM Per9	PWM Per8	0x00	
0x16	PWM1delLSB	PWM1 Del7	PWM1 Del6	PWM1 Del5	PWM1 Del4	PWM1 Del3	PWM1 Del2	PWM1 Del1	PWM1 Del0	0x00	
0x17	PWM1delMSB	0	0	0	0	PWM1 Del11	PWM1 Del10	PWM1 Del9	PWM1 Del8	0x00	
0x18	PWM2delLSB	PWM2 Del7	PWM2 Del6	PWM2 Del5	PWM2 Del4	PWM2 Del3	PWM2 Del2	PWM2 Del1	PWM2 Del0	0x00	
0x19	PWM2delMSB	0	0	0	0	PWM2 Del11	PWM2 Del10	PWM2 Del9	PWM2 Del8	0x00	
0x1A	PWM3delLSB	PWM3 Del7	PWM3 Del6	PWM3 Del5	PWM3 Del4	PWM3 Del3	PWM3 Del2	PWM3 Del1	PWM3 Del0	0x00	
0x1B	PWM3delMSB	0	0	0	0	PWM3 Del11	PWM3 Del10	PWM3 Del9	PWM3 Del8	0x00	
0x1C	PWM4delLSB	PWM4 Del7	PWM4 Del6	PWM4 Del5	PWM4 Del4	PWM4 Del3	PWM4 Del2	PWM4 Del1	PWM4 Del0	0x00	
0x1D	PWM4delMSB	0	0	0	0	PWM4 Del11	PWM4 Del10	PWM4 Del9	PWM4 Del8	0x00	
0x1E	PWM5delLSB	PWM5 Del7	PWM5 Del6	PWM5 Del5	PWM5 Del4	PWM5 Del3	PWM5 Del2	PWM5 Del1	PWM5 Del0	0x00	
0x1F	PWM5delMSB	0	0	0	0	PWM5 Del11	PWM5 Del10	PWM5 Del9	PWM5 Del8	0x00	
0x20	PWM6delLSB	PWM6 Del7	PWM6 Del6	PWM6 Del5	PWM6 Del4	PWM6 Del3	PWM6 Del2	PWM6 Del1	PWM6 Del0	0x00	
0x21	PWM6delMSB	0	0	0	0	PWM6 Del11	PWM6 Del10	PWM6 Del9	PWM6 Del8	0x00	
0x22	PWM7delLSB	PWM7 Del7	PWM7 Del6	PWM7 Del5	PWM7 Del4	PWM7 Del3	PWM7 Del2	PWM7 Del1	PWM7 Del0	0x00	
0x23	PWM7delMSB	0	0	0	0	PWM7 Del11	PWM7 Del10	PWM7 Del9	PWM7 Del8	0x00	
0x24	PWM8delLSB	PWM8 Del7	PWM8 Del6	PWM8 Del5	PWM8 Del4	PWM8 Del3	PWM8 Del2	PWM8 Del1	PWM8 Del0	0x00	
0x25	PWM8delMSB	0	0	0	0	PWM8 Del11	PWM8 Del10	PWM8 Del9	PWM8 Del8	0x00	
0x26	PWM9delLSB	PWM9 Del7	PWM9 Del6	PWM9 Del5	PWM9 Del4	PWM9 Del3	PWM9 Del2	PWM9 Del1	PWM9 Del0	0x00	
0x27	PWM9delMSB	0	0	0	0	PWM9 Del11	PWM9 Del10	PWM9 Del9	PWM9 Del8	0x00	

0x28	PWM10delLSB	PWM10 Del7	PWM10 Del6	PWM10 Del5	PWM10 Del4	PWM10 Del3	PWM10 Del2	PWM10 Del1	PWM10 Del0	0x00
0x29	PWM10delMSB	0	0	0	0	PWM10 Del11	PWM10 Del10	PWM10 Del9	PWM10 Del8	0x00
0x2A	PWM11delLSB	PWM11 Del7	PWM11 Del6	PWM11 Del5	PWM11 Del4	PWM11 Del3	PWM11 Del2	PWM11 Del1	PWM11 Del0	0x00
0x2B	PWM11delMSB	0	0	0	0	PWM11 Del11	PWM11 Del10	PWM11 Del9	PWM11 Del8	0x00
0x2C	PWM12delLSB	PWM12 Del7	PWM12 Del6	PWM12 Del5	PWM12 Del4	PWM12 Del3	PWM12 Del2	PWM12 Del1	PWM12 Del0	0x00
0x2D	PWM12delMSB	0	0	0	0	PWM12 Del11	PWM12 Del10	PWM12 Del9	PWM12 Del8	0x00
0x2E	PWM13delLSB	PWM13 Del7	PWM13 Del6	PWM13 Del5	PWM13 Del4	PWM13 Del3	PWM13 Del2	PWM13 Del1	PWM13 Del0	0x00
0x2F	PWM13delMSB	0	0	0	0	PWM13 Del11	PWM13 Del10	PWM13 Del9	PWM13 Del8	0x00
0x30	PWM14delLSB	PWM14 Del7	PWM14 Del6	PWM14 Del5	PWM14 Del4	PWM14 Del3	PWM14 Del2	PWM14 Del1	PWM14 Del0	0x00
0x31	PWM14delMSB	0	0	0	0	PWM14 Del11	PWM14 Del10	PWM14 Del9	PWM14 Del8	0x00
0x32	PWM15delLSB	PWM15 Del7	PWM15 Del6	PWM15 Del5	PWM15 Del4	PWM15 Del3	PWM15 Del2	PWM15 Del1	PWM15 Del0	0x00
0x33	PWM15delMSB	0	0	0	0	PWM15 Del11	PWM15 Del10	PWM15 Del9	PWM15 Del8	0x00
0x34	PWM16delLSB	PWM16 Del7	PWM16 Del6	PWM16 Del5	PWM16 Del4	PWM16 Del3	PWM16 Del2	PWM16 Del1	PWM16 Del0	0x00
0x35	PWM16delMSB	0	0	0	0	PWM16 Del11	PWM16 Del10	PWM16 Del9	PWM16 Del8	0x00
0x36	LOCKUNLOC	MagicByte								0x00
0x37	PWM1htLSB	PWM1 HT7	PWM1 HT6	PWM1 HT5	PWM1 HT4	PWM1 HT3	PWM1 HT2	PWM1 HT1	PWM1 HT0	0x00
0x38	PWM1htMSB	0	0	0	0	PWM1 HT11	PWM1 HT10	PWM1 HT9	PWM1 HT8	0x00
0x39	PWM2htLSB	PWM2 HT7	PWM2 HT6	PWM2 HT5	PWM2 HT4	PWM2 HT3	PWM2 HT2	PWM2 HT1	PWM2 HT0	0x00
0x3A	PWM2htMSB	0	0	0	0	PWM2 HT11	PWM2 HT10	PWM2 HT9	PWM2 HT8	0x00
0x3B	PWM3htLSB	PWM3 HT7	PWM3 HT6	PWM3 HT5	PWM3 HT4	PWM3 HT3	PWM3 HT2	PWM3 HT1	PWM3 HT0	0x00
0x3C	PWM3htMSB	0	0	0	0	PWM3 HT11	PWM3 HT10	PWM3 HT9	PWM3 HT8	0x00
0x3D	PWM4htLSB	PWM4 HT7	PWM4 HT6	PWM4 HT5	PWM4 HT4	PWM4 HT3	PWM4 HT2	PWM4 HT1	PWM4 HT0	0x00
0x3E	PWM4htMSB	0	0	0	0	PWM4 HT11	PWM4 HT10	PWM4 HT9	PWM4 HT8	0x00
0x3F	PWM5htLSB	PWM5 HT7	PWM5 HT6	PWM5 HT5	PWM5 HT4	PWM5 HT3	PWM5 HT2	PWM5 HT1	PWM5 HT0	0x00
0x40	PWM5htMSB	0	0	0	0	PWM5 HT11	PWM5 HT10	PWM5 HT9	PWM5 HT8	0x00
0x41	PWM6htLSB	PWM6 HT7	PWM6 HT6	PWM6 HT5	PWM6 HT4	PWM6 HT3	PWM6 HT2	PWM6 HT1	PWM6 HT0	0x00
0x42	PWM6htMSB	0	0	0	0	PWM6 HT11	PWM6 HT10	PWM6 HT9	PWM6 HT8	0x00
0x43	PWM7htLSB	PWM7 HT7	PWM7 HT6	PWM7 HT5	PWM7 HT4	PWM7 HT3	PWM7 HT2	PWM7 HT1	PWM7 HT0	0x00
0x44	PWM7htMSB	0	0	0	0	PWM7 HT11	PWM7 HT10	PWM7 HT9	PWM7 HT8	0x00
0x45	PWM8htLSB	PWM8 HT7	PWM8 HT6	PWM8 HT5	PWM8 HT4	PWM8 HT3	PWM8 HT2	PWM8 HT1	PWM8 HT0	0x00
0x46	PWM8htMSB	0	0	0	0	PWM8 HT11	PWM8 HT10	PWM8 HT9	PWM8 HT8	0x00
0x47	PWM9htLSB	PWM9 HT7	PWM9 HT6	PWM9 HT5	PWM9 HT4	PWM9 HT3	PWM9 HT2	PWM9 HT1	PWM9 HT0	0x00
0x48	PWM9htMSB	0	0	0	0	PWM9 HT11	PWM9 HT10	PWM9 HT9	PWM9 HT8	0x00
0x49	PWM10htLSB	PWM10 HT7	PWM10 HT6	PWM10 HT5	PWM10 HT4	PWM10 HT3	PWM10 HT2	PWM10 HT1	PWM10 HT0	0x00
0x4A	PWM10htMSB	0	0	0	0	PWM10 HT11	PWM10 HT10	PWM10 HT9	PWM10 HT8	0x00
0x4B	PWM11htLSB	PWM11 HT7	PWM11 HT6	PWM11 HT5	PWM11 HT4	PWM11 HT3	PWM11 HT2	PWM11 HT1	PWM11 HT0	0x00
0x4C	PWM11htMSB	0	0	0	0	PWM11 HT11	PWM11 HT10	PWM11 HT9	PWM11 HT8	0x00
0x4D	PWM12htLSB	PWM12 HT7	PWM12 HT6	PWM12 HT5	PWM12 HT4	PWM12 HT3	PWM12 HT2	PWM12 HT1	PWM12 HT0	0x00
0x4E	PWM12htMSB	0	0	0	0	PWM12 HT11	PWM12 HT10	PWM12 HT9	PWM12 HT8	0x00
0x4F	PWM13htLSB	PWM13 HT7	PWM13 HT6	PWM13 HT5	PWM13 HT4	PWM13 HT3	PWM13 HT2	PWM13 HT1	PWM13 HT0	0x00
0x50	PWM13htMSB	0	0	0	0	PWM13 HT11	PWM13 HT10	PWM13 HT9	PWM13 HT8	0x00
0x51	PWM14htLSB	PWM14 HT7	PWM14 HT6	PWM14 HT5	PWM14 HT4	PWM14 HT3	PWM14 HT2	PWM14 HT1	PWM14 HT0	0x00

0x52	PWM14htMSB	0	0	0	0	PWM14 HT11	PWM14 HT10	PWM14 HT9	PWM14 HT8	0x00	
0x53	PWM15htLSB	PWM15 HT7	PWM15 HT6	PWM15 HT5	PWM15 HT4	PWM15 HT3	PWM15 HT2	PWM15 HT1	PWM15 HT0	0x00	
0x54	PWM15htMSB	0	0	0	0	PWM5 HT11	PWM15 HT10	PWM15 HT9	PWM15 HT8	0x00	
0x55	PWM16htLSB	PWM16 HT7	PWM16 HT6	PWM16 HT5	PWM16 HT4	PWM16 HT3	PWM16 HT2	PWM16 HT1	PWM16 HT0	0x00	
0x56	PWM16htMSB	0	0	0	0	PWM16 HT11	PWM16 HT10	PWM16 HT9	PWM16 HT8	0x00	
0x57	ASICIDLSB	C				Rev Nr.				0xCX	
0x58	ASICIDMSB	9				5				0x95	
0x59	Not used										0x00
0x60	STATUS	STAT Nosync	STAT OT	STAT Open	STAT Short	0	STAT UVLO	STAT power			
0x61	PLLctrl1	NC div7	NC div6	NC div5	NC div4	NC div3	NC div2	NC div1	NC div0	0x00	
0x62	PLLctrl2	AC div4	AC div3	AC div2	AC div1	AC div0	NC div10	NC div9	NC div8	0x00	
0x63	PLLctrl3			ICP2	ICP1	ICP0	OD div2	OD div1	OD div0	0x00	

ADDRESSES ABOVE 0x63 ARE FOR FACTORY TEST ONLY. DO NOT WRITE !

7 Pinout

Pin Nr	Pin Name	Pin Type	Description
1	G2	AIO	Connect to Gate of External Transistor
2	G1	AIO	Connect to Gate of External Transistor
3	S1	AIO	Connect to Source of External Transistor and to Resistor RSET
4	D1	AIO	Connect to Drain of external Transistor
5	V2_5	AIO	Digital supply output. Connect 2.2uF bypass capacitor to GND
6	xFAULT	DO- OD	Fault output. Open drain. Connect pullup to VDD
7	xRES	DI	Reset input active low
8	FB1	AIO	Power supply feedback output1
9	FB2	AIO	Power supply feedback output2
10	VSSA	AIO	GND
11	VDD	AIO	Power supply. Connect 4.7uF bypass capacitor to GND
12	VSS_SENSE	AIO	VSS sense input. Keep this node noise free
13	D16	AIO	Connect to Drain of external Transistor
14	S16	AIO	Connect to Source of External Transistor and to Resistor RSET
15	G16	AIO	Connect to Gate of External Transistor
16	G15	AIO	Connect to Gate of External Transistor
17	S15	AIO	Connect to Source of External Transistor and to Resistor RSET
18	D15	AIO	Connect to Drain of external Transistor
19	D14	AIO	Connect to Drain of external Transistor
20	S14	AIO	Connect to Source of External Transistor and to Resistor RSET
21	G14	AIO	Connect to Gate of External Transistor
22	G13	AIO	Connect to Gate of External Transistor
23	S13	AIO	Connect to Source of External Transistor and to Resistor RSET
24	D13	AIO	Connect to Drain of external Transistor
25	D12	AIO	Connect to Drain of external Transistor
26	S12	AIO	Connect to Source of External Transistor and to Resistor RSET
27	G12	AIO	Connect to Gate of External Transistor
28	G11	AIO	Connect to Gate of External Transistor
29	S11	AIO	Connect to Source of External Transistor and to Resistor RSET
30	D11	AIO	Connect to Drain of external Transistor
31	D10	AIO	Connect to Drain of external Transistor
32	S10	AIO	Connect to Source of External Transistor and to Resistor RSET
33	G10	AIO	Connect to Gate of External Transistor
34	G9	AIO	Connect to Gate of External Transistor
35	S9	AIO	Connect to Source of External Transistor and to Resistor RSET
36	D9	AIO	Connect to Drain of external Transistor

37	Filt2	AIO	PLL loop filter. Connect to GND if PLL is not used
38	Filt1	AIO	PLL loop filter. Connect to GND if PLL is not used
39	VSYNC	DI-PD	Vertical sync frequency
40	HSYNC	DI-PD	Clock input for PWM generators
41	xCS	DI-PU	SPI interface chip select
42	SDO	DO	SPI interface data output. Tristate output
43	SCL	DI-PD	SPI interface clock
44	SDI	DI-PD	SPI interface data input
45	D8	AIO	Connect to Drain of external Transistor
46	S8	AIO	Connect to Source of External Transistor and to Resistor RSET
47	G8	AIO	Connect to Gate of External Transistor
48	G7	AIO	Connect to Gate of External Transistor
49	S7	AIO	Connect to Source of External Transistor and to Resistor RSET
50	D7	AIO	Connect to Drain of external Transistor
51	D6	AIO	Connect to Drain of external Transistor
52	S6	AIO	Connect to Source of External Transistor and to Resistor RSET
53	G6	AIO	Connect to Gate of External Transistor
54	G5	AIO	Connect to Gate of External Transistor
55	S5	AIO	Connect to Source of External Transistor and to Resistor RSET
56	D5	AIO	Connect to Drain of external Transistor
57	D4	AIO	Connect to Drain of external Transistor
58	S4	AIO	Connect to Source of External Transistor and to Resistor RSET
59	G4	AIO	Connect to Gate of External Transistor
60	G3	AIO	Connect to Gate of External Transistor
61	S3	AIO	Connect to Source of External Transistor and to Resistor RSET
62	D3	AIO	Connect to Drain of external Transistor
63	D2	AIO	Connect to Drain of external Transistor
64	S2	AIO	Connect to Source of External Transistor and to Resistor RSET
EP	VSSA	AIO	Exposed PAD. Connect to VSSA (QFN package only)

Note: If an output channel X is not used, short Gx and Sx, leave Dx open.

AIO	Analog Pin
DI	Digital input
DI-PU	Digital input with pull up resistor
DI-PD	Digital input with pull down resistor
DO	Digital output
DO-OD	Digital output open drain

8 Package drawings and Markings

Marking



Packaging code

YY	WW	I	ZZ
Last two digits of the current year	Manufacturing week	Plant identifier	Letters for free choice

8.1 Package Drawing QFN64

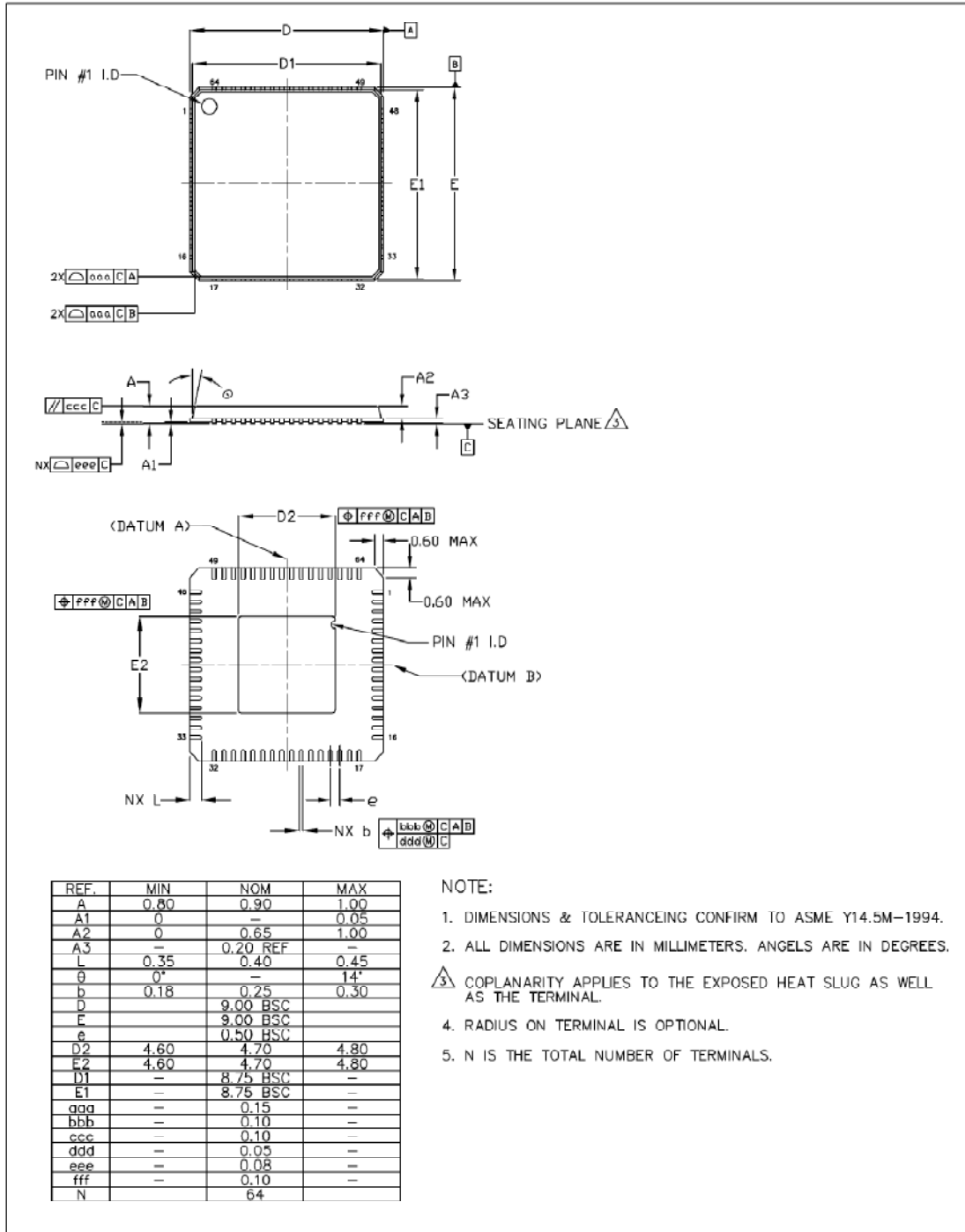

		ASSEMBLY ENGINEERING		
<i>a leap ahead in analog</i>		TITLE PUNCHED QFN, PULL BACK 9x9x0.9mm 64 LD. 4.70mm SQ. ePAD		REFERENCE DOCUMENT JEDEC MO - 220 LATEST REVISION
DRAWN RHB	DATE 2010.10.22	REV. N/C	DRAWING NO. QRJ	UNIT
CHECKED GBO	DATE 2010.10.22	SHEET 1 of 1	DIMENSION AND TOLERANCE	SCALE NOT IN SCALE
APPROVED MKR	DATE 2010.10.22			



8.2 Package Drawing LQFP64

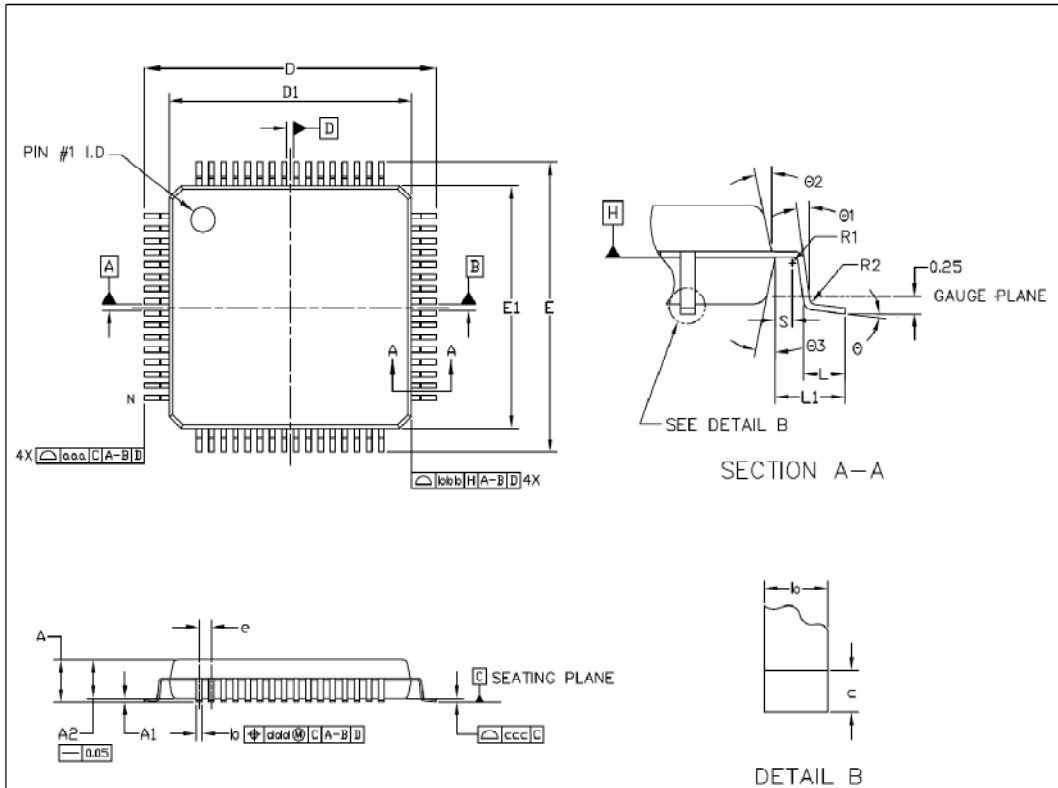

REF.	MIN	NOM	MAX
A	0.05	—	1.60
A1	1.35	—	1.45
A2	1.35	1.40	1.45
b	0.30	0.37	0.45
c	0.09	—	0.20
D	—	16.00 BSC	—
D1	—	14.00 BSC	—
D2	2.00	—	—
E	—	16.00 BSC	—
E1	—	14.00 BSC	—
E2	2.00	—	—
e	—	0.80 BSC	—
L	0.45	0.60	0.75
L1	—	1.00 REF	—
R1	0.08	—	—
R2	0.08	—	0.20
S	0.20	—	—
θ	0°	3.5°	7°
θ1	0°	—	—
θ2	11°	12°	13°
θ3	11°	12°	13°
ggg	—	0.20	—
bbb	—	0.20	—
ccc	—	0.10	—
ddd	—	0.20	—
N	—	64	—

NOTE:

1. DIMENSIONS & TOLERANCEING CONFIRM TO ASME Y14.5M-1994.
2. ALL DIMENSIONS ARE IN MILLIMETERS. ANGELS ARE IN DEGREES.

			ASSEMBLY ENGINEERING	
a leap ahead in analog			TITLE	REFERENCE DOCUMENT
DRAWN	DATE	REV.	LQFP 14x14x1.4mm, 64 LEAD	JEDEC MS - 026
RH8	2010.10.21	N/C	DRAWING NO.	LATEST REVISION
CHECKED	DATE		BQY	UNIT
GBO	2010.10.21			
APPROVED	DATE	SHEET	DIMENSION AND TOLERANCE	SCALE
MKR	2010.10.21	1 OF 1		NOT IN SCALE



9 Thermal characteristic

The thermal characteristics of the devices were measured at 25 °C ambient temperature. The device was mounted on a double sided FR4 PCB with the bottom layer used as cooling area.

9.1 QFN64

PCB FR4, 1cm distance from ground

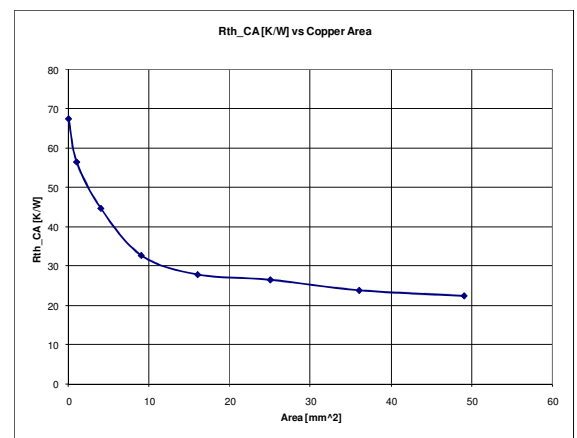
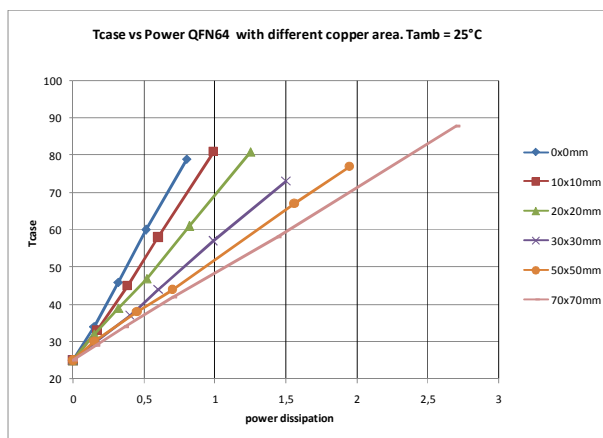
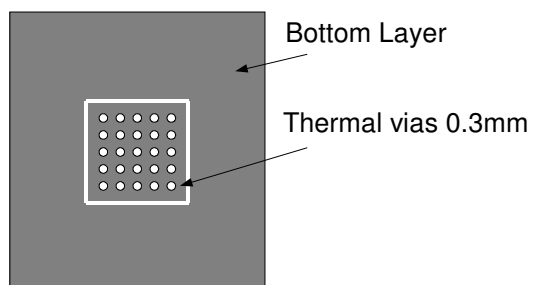

10 Ordering information

Part Number	Marking	Package Type	Delivery Form	Description
AS3695C-ZMFT	AS3695C	QFN64	Tape and Reel in Dry Pack	Package size = 9x9mm, Pitch = 0.5mm, Pb-free;
AS3695C-ZLQT	AS3695C	LQFP64	Tape and Reel in Dry Pack	Package size = 14x14mm, Pitch = 0.8mm, Pb-free;

Copyright

Copyright © 1997-2009, austriamicrosystems AG, Schloss Premstaetten, 8141 Unterpremstaetten, Austria-Europe. Trademarks Registered ®. All rights reserved. The material herein may not be reproduced, adapted, merged, translated, stored, or used without the prior written consent of the copyright owner.

All products and companies mentioned are trademarks or registered trademarks of their respective companies.

Disclaimer

Devices sold by austriamicrosystems AG are covered by the warranty and patent indemnification provisions appearing in its Term of Sale. austriamicrosystems AG makes no warranty, express, statutory, implied, or by description regarding the information set forth herein or regarding the freedom of the described devices from patent infringement. Austriamicrosystems AG reserves the right to change specifications and prices at any time and without notice. Therefore, prior to designing this product into a system, it is necessary to check with austriamicrosystems AG for current information.

This product is intended for use in normal commercial applications. Applications requiring extended temperature range, unusual environmental requirements, or high reliability applications, such as military, medical life-support or life-sustaining equipment are specifically not recommended without additional processing by austriamicrosystems AG for each application. For shipments of less than 100 parts the manufacturing flow might show deviations from the standard production flow, such as test flow or test location. The information furnished here by austriamicrosystems AG is believed to be correct and accurate. However, austriamicrosystems AG shall not be liable to recipient or any third party for any damages, including but not limited to personal injury, property damage, loss of profits, loss of use, interruption of business or indirect, special, incidental or consequential damages, of any kind, in connection with or arising out of the furnishing, performance or use of the technical data herein. No obligation or liability to recipient or any third party shall arise or flow out of austriamicrosystems AG rendering of technical or other services.



Contact Information

Headquarters
austriamicrosystems AG
A-8141 Schloss Premstätten, Austria

T. +43 (0) 3136 500 0
F. +43 (0) 3136 5692

For Sales Offices, Distributors and Representatives, please visit:

<http://www.austriamicrosystems.com/contact>