

16-Channel White LED Controller for LCD Backlight

1 Description

The AS3820 is a 16 channel precision LED controller for use in LCD-backlight panels.

Dynamic power feedback controls the external power supply to guarantee best efficiency. Built-in safety features include thermal shutdown as well as open and short LED detection. The device is programmable via serial interface.

2 Features

- All LED backlight topologies
 - » No limit of VLED or ILED, device is not exposed to high voltage/high current
- Optimum power savings through local dimming
 - » 16 fully flexible 12 bit PWM generators (period, high time, delay, reverse)
- Highest brightness uniformity
 - » One global high accuracy 10 bit DAC which sets the LED current ($\pm 0.5\%$ accuracy)
- Full platform approach
 - » Dedicated device family (AS382x)⁽¹⁾ is available, all SW compatible
- Global dimming mode available
 - » AS3820E is pre-programmed to external PWM mode. VSYNC pin is used as PWM input
- Synchronization with TV frame
 - » VSYNC and HSYNC inputs available as well as a digital PLL integrated⁽²⁾
- Lowest BOM
 - » Due to 2 pin concept of the output channel: no HV protection, no cascade FETs
- Digital enhanced DC-DC feedback
 - » Feedback function is compatible to every DC-DC architecture and configurable via SPI⁽²⁾
- On chip safety features
 - » Short/open LED detection, temperature shutdown, register lock/unlock, SPI transfer checksum

3 Applications

- The AS3820 is suitable for LED backlighting for LCD such as TV sets and monitors.

Notes:

Note 1. The device family AS382x includes AS3820 and AS3824.

Note 2. Patent protected

16-Channel White LED Controller for LCD Backlight

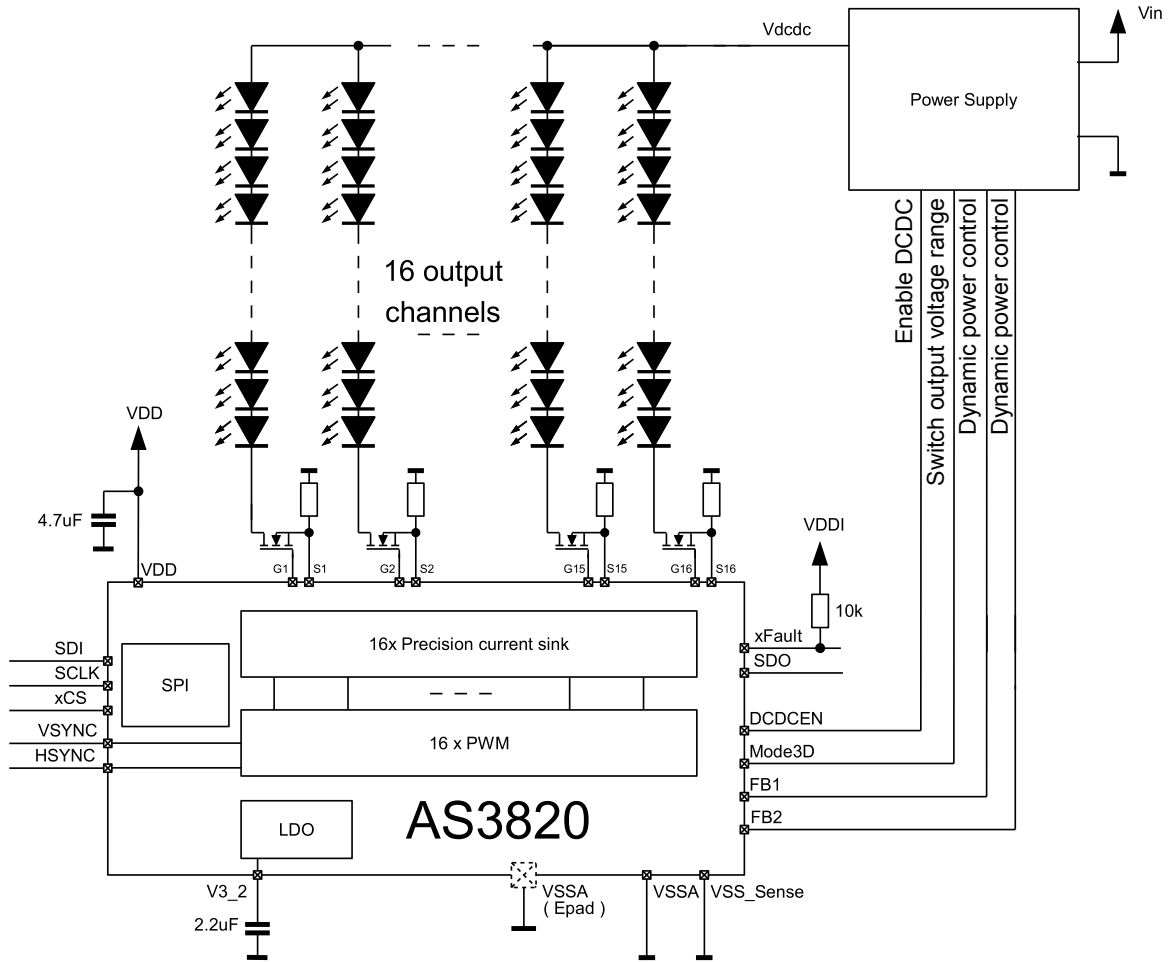

Figure 3.1 : AS3820 Typical Application

16-Channel White LED Controller for LCD Backlight

4 Pinout Description

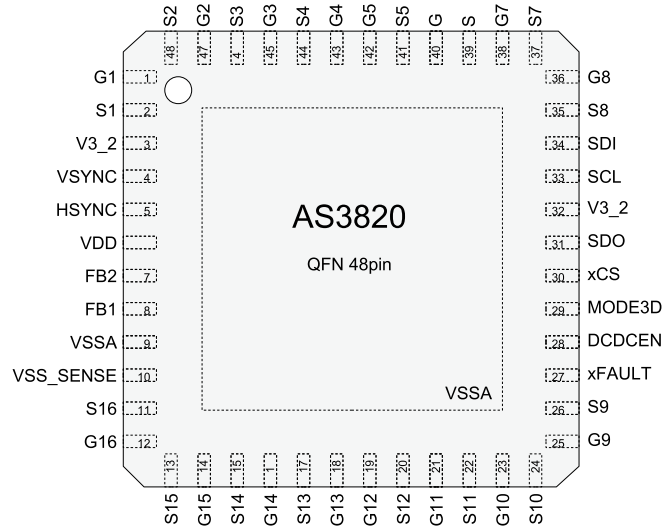

Figure 4.1 : QFN-48 Pin Diagram of AS3820 (Top View)

Pin Number	Pin Name	Type	Pin Description
1	G1	A_I/O	Connect to gate of external transistor
2	S1	A_I/O	Connect to source of external transistor
3	V3_2	P	Digital supply output. Connect 2.2µF capacitor to GND
4	VSYNC	DI_PD	Vertical sync frequency
5	HSYNC	DI_PD	Clock input for PWM generators
6	V _{DD}	P	Power supply. Connect 4.7µF bypass capacitor to GND
7	FB2	A_I/O	Power supply feedback output2
8	FB1	A_I/O	Power supply feedback output1
9	VSSA	P	GND
10	VSS_SENSE	P	GND
11	S16	A_I/O	Connect to source of external transistor
12	G16	A_I/O	Connect to gate of external transistor
13	S15	A_I/O	Connect to source of external transistor
14	G15	A_I/O	Connect to gate of external transistor
15	S14	A_I/O	Connect to source of external transistor

16-Channel White LED Controller for LCD Backlight

4 Pinout Description (cont'd)

Pin Number	Pin Name	Type	Pin Description
16	G14	A_I/O	Connect to gate of external transistor
17	S13	A_I/O	Connect to source of external transistor
18	G13	A_I/O	Connect to gate of external transistor
19	G12	A_I/O	Connect to gate of external transistor
20	S12	A_I/O	Connect to source of external transistor
21	G11	A_I/O	Connect to gate of external transistor
22	S11	A_I/O	Connect to source of external transistor
23	G10	A_I/O	Connect to gate of external transistor
24	S10	A_I/O	Connect to source of external transistor
25	G9	A_I/O	Connect to gate of external transistor
26	S9	A_I/O	Connect to source of external transistor
27	xFAULT	DO_OD	Fault output. Open drain. Connect pullup to V3_2
28	DCDCEN	DO	GPIO output to enable DC-DC converter
29	MODE3D	DO	GPIO output to enable 3D mode
30	xCS	DI_PU	SPI interface chip select
31	SDO	DO	SPI interface data output. Tristate output
32	V3_2	P	LED current output
33	SCL	DI_PD	Exposed Pad: Connect to GND
34	SDI	DI_PD	Digital supply output
35	S8	A_I/O	Connect to source of external transistor
36	G8	A_I/O	Connect to gate of external transistor
37	S7	A_I/O	Connect to source of external transistor
38	G7	A_I/O	Connect to gate of external transistor
39	S6	A_I/O	Connect to source of external transistor
40	G6	A_I/O	Connect to gate of external transistor
41	S5	A_I/O	Connect to source of external transistor
42	G5	A_I/O	Connect to gate of external transistor
43	G4	A_I/O	Connect to gate of external transistor

16-Channel White LED Controller for LCD Backlight

4 Pinout Description (cont'd)

Pin Number	Pin Name	Type	Pin Description
44	S4	A_I/O	Connect to source of external transistor
45	G3	A_I/O	Connect to gate of external transistor
46	S3	A_I/O	Connect to source of external transistor
47	G2	A_I/O	Connect to gate of external transistor
48	S2	A_I/O	Connect to source of external transistor
EP	VSSA	P	Exposed PAD. Connect to VSSP

Note 1. If an output channel X is not used, short Gx and Sx.

A_I/O: Analog pin

P: Power pin

DO: Digital Output

DO_OD: Digital Output Open Drain

DI: Digital Input

DI_PU: Digital Input with Pull Up resistor

DI_PD: Digital Input with Pull Down resistor

16-Channel White LED Controller for LCD Backlight

5 Absolute Maximum Ratings

Absolute maximum ratings are the parameter values or ranges which can cause permanent damage if exceeded. For maximum safe operating conditions, refer to the Electrical Characteristics section.

Parameter	Symbol	Test Conditions	Min	Max	Unit
Electrical Parameters					
Supply Voltage to Ground	V_{DDMAX}	Applicable for pin VDD	-0.3	7	V
Maximum Voltage Analog pins	V_{ANA_MAX}	(Note 1)	-0.3	7	V
Maximum Voltage Digital pins	V_{DIG_MAX}	(Note 2)	-0.3	5	V
Latch-up Immunity	I_{LATCH}	JEDEC JESD78D Nov 2011	±100		mA
Electrostatic Discharge					
Electrostatic Discharge	ESD_{HBM}	Norm: MIL 883 E Method 3015 Human body model	±2000		V
Temperature Ranges and Storage Conditions					
Junction Temperature	T_{JMAX}			150	°C
Storage Temperature Range	T_{STRG}		-55	150	°C
Package Body Temperature	T_{BODY}	The reflow peak soldering temperature (body temperature) specified is in accordance with IPC/JEDEC J-STD-020 "Moisture/Reflow Sensitivity Classification for Non-Hermetic Solid State Surface Mount Devices". The lead finish for Pb-free leaded packages is matte tin (100% Sn)		260	°C
Relative Humidity (non-condensing)	RH_{NC}		5	85	%
Moisture Sensitivity Level	MSL	Maximum floor life time of 168h	3		

Notes:

Note 1. Pins: FB1,FB2,G1-G16, S1-S16,VSYNC, HSYNC.

Note 2. Pins: V3_2, SDI, SDO, SCL, xCS, MODE3D, DCDGEN, xFAULT.

16-Channel White LED Controller for LCD Backlight

6 Electrical Characteristics

All limits are guaranteed. The parameters with min and max values are guaranteed with production tests or SQC (Statistical Quality Control) methods. $V_{CC} = 12V$, $-40^{\circ}C \leq T_A \leq 85^{\circ}C$, unless otherwise specified.

Parameter	Symbol	Test Conditions	Min	Typ	Max	Unit
Thermal Resistance case – ambient	R_{THCA}	See section 8.10				$^{\circ}C/W$
Junction Temperature	T_J		-20		115	$^{\circ}C$
Supply Voltages						
Supply Voltage	VDD		4.5		5.5	V
Voltage Regulator Output	V_{3_2}	$I_{LOAD} = 20mA$	3.0	3.2	3.4	V
Power-on Reset Level	$V_{3_2_POR}$	Circuit stays in power down until V_{3_2} reaches $V_{3_2_POR}$	1.6		2.2	V
Under voltage Lockout Level	V_{DD_UVL}	Current outputs are turned OFF if V_{DD} is lower than V_{DD_UVL} . This is done by resetting the CURRx bits.	2.4		2.9	V
Quiescent Current, PWM = "0"	IDD_Q	VDD = 5V, default setting		12		mA
Supply Current	IDD_R	VDD = 5V, HSYNC = 1MHz, VSYNC = 480Hz, Duty = 50%, VDAC = 250mV		13		mA
Current Outputs						
Trimmed Current Accuracy at 25°C	$I_{LED_500_250}$	Trimmed during production. ILED = 100mA, DACref = 500mV, VDAC = 250mV, $T_J = 25^{\circ}C$ (excluding error of external Rset)	-0.5		+0.5	%
Channel to Channel Accuracy at 25°C	I_{CH_250}	ILED=100mA, DACref = 500mV, VDAC = 250mV, $T_J = 25^{\circ}C$ (excluding error of external Rset)	-0.2		+0.2	%
Current Accuracy Over VDAC	$I_{LED_500_ALL}$	DACref = 500mV, VDAC = 200mV - 500mV, $T_J = 25^{\circ}C$ (excluding error of external Rset)	-1.5		+1.5	%
Current Accuracy Over VDAC and Temperature	$I_{LED_500_TMP}$	DACref = 500mV, VDAC = 200mV – 500mV $T_J = -20^{\circ}C$ to $115^{\circ}C$ (excluding error of external Rset)	-2		+2	%
Trimmed Current Accuracy at 25°C	$I_{LED_800_250}$	Trimmed during production. ILED = 100mA, DACref = 800mV, VDAC = 250mV, $T_J = 25^{\circ}C$ (excluding error of external Rset)	-0.5		+0.5	%

16-Channel White LED Controller for LCD Backlight

Electrical Characteristics (cont.)

$V_{CC} = 12V$, $-40^{\circ}C \leq T_A \leq 85^{\circ}C$, unless otherwise specified

Parameter	Symbol	Test Conditions	Min	Typ	Max	Unit
Current Outputs (cont'd)						
LED Current Accuracy Over VDAC	I_{800_ALL}	DACref = 800mV, VDAC = 200mV - 800mV, $T_J = 25^{\circ}C$ (excluding error of external Rset)	-1.5		+1.5	%
LED Current Accuracy Over VDAC and Temperature	I_{800_TEMP}	DACref = 800mV, VDAC = 200mV - 800mV, $T_J = -20^{\circ}C$ to $115^{\circ}C$ (excluding error of external Rset)	-2		+2	%
Output current pin Gx	IGX		3		4	mA
Output resistor pin Gx	RGX			1.0	1.3	k Ω
Output voltage pin Gx	Vgx	$I_{gx} = 0mA$			V_{DD}	V
Feedback Circuit, Fault Detectors						
Feedback Current Maximum	IFB_{MAX}	$V_{FB_X} > 0.25V$		255		μA
Step Size of FB Counter (LSB)	FB_IDAC_LSB			1		μA
Overtemperature Limit	T_{OVTEMP}		130	140	150	$^{\circ}C$
Overtemperature Hysteresis	T_{HYST}			10		$^{\circ}C$
Minimum Time to Detect Short	t_{SHORT_MIN}		300			μs
PWM Generators						
Internal Clock for PWM	f_{OSC}		400	500	600	kHz
HSYNC Frequency	f_{HSYNC}		100		2000	kHz
VSYSN Frequency	f_{VSYSN}		60		480	Hz
Digital Pins						
High Level Input Voltage	V_{IH}		1.3		$V3_2 + 0.3$	V
Low Level Input Voltage	V_{IL}		-0.3		0.8	V
High Level Output Voltage	V_{OH}	$I = 2mA$	$V3_2 - 0.3$			V
Low Level Output Voltage	V_{OL}	$I = 2mA$			0.3	V
Low Level Output Voltage Open Drain Outputs	V_{OL_PD}	$I = 2mA$			0.3	V
Input Resistance Pullup Inputs	R_{PU}			300		k Ω
Input Resistance Pulldown Inputs	R_{PD}			300		k Ω

16-Channel White LED Controller for LCD Backlight

7 Functional Block Diagram

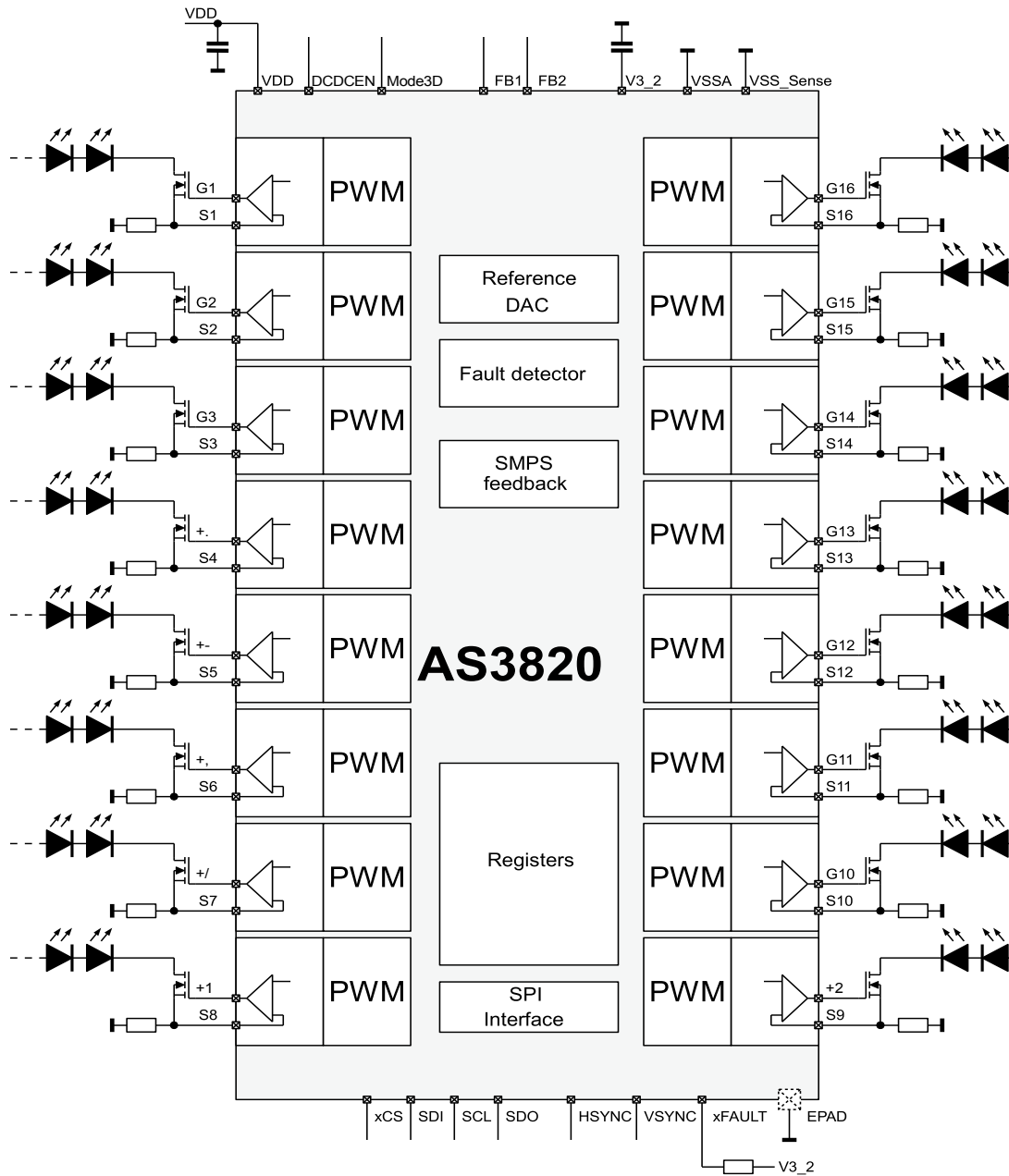

Figure 7.1 : AS3820 Functional Block Diagram

16-Channel White LED Controller for LCD Backlight

7.1 Pin Equivalent Circuits

VDD	
Digital Input	
Digital Input with PullUp	
Digital Input with PullDown	
Digital Inputs HSYNC,VSYNC	
Digital Output PushPull	
Digital Output Open Drain	
Feedback Output	
Analog I/O	

Figure 7.2 : Pin Equivalent Circuits

16-Channel White LED Controller for LCD Backlight

8 Detailed Description

This section provides a detailed description of the device related components.

8.1 Current Outputs

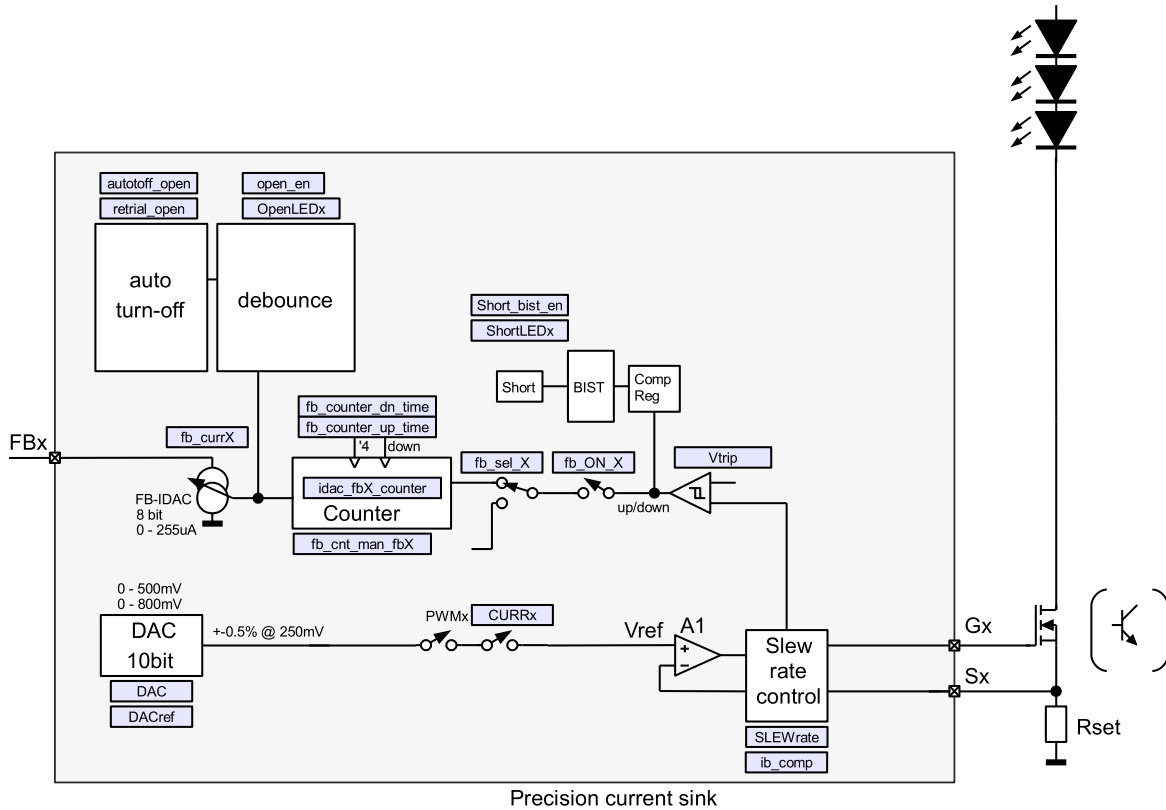

Figure 8.1 : Detailed Block Diagram of Precision Current Sink

8.1.1 Precision Current Sink

All current sinks are built with an internal error amplifier A1 and an external power transistor. The external transistor can either be a NMOS or a NPN bipolar transistor. For low EMI radiation the slew rate of the amplifier output voltage can be adjusted.

8.1.2 Power Supply Feedback

The gate driving voltage for the external transistor is monitored to adjust the power supply output. If this voltage gets to high a comparator enables counting up of the “idac_fbX_counter” with 256µs clock speed. This increases the output current of the FB-IDAC and so the output voltage of the external power supply can be increased via pin FB1 or pin FB2. The feedback function of each output can be assigned to either FB1 or FB2. The power supply feedback can be turned OFF for every current channel separately.

8.1.3 Manual Control of the External Power Supply Voltage

The counter value “idac_fbX_counter” can also be preset by software if “fbcounter_man_fx” =1. This enables software control of the external power supply output voltage.

16-Channel White LED Controller for LCD Backlight

8.1.4 Open LED Detection

If open led detection is enabled a broken LED-string is detected during PWM=1. If a LED-string is broken and the feedback function is enabled, the “idac_fbX_counter” will count up in order to increase the power supply output voltage. After the “idac_fbX_counter” has reached its maximum value, a debounce counter is started. In order to run the debounce counter, the corresponding PWM-signal has to be high for more than 150 μ s. After the debounce counter has counted up for 32ms, the corresponding “OPENLED_x” bit is set and the output xFAULT = “0”.

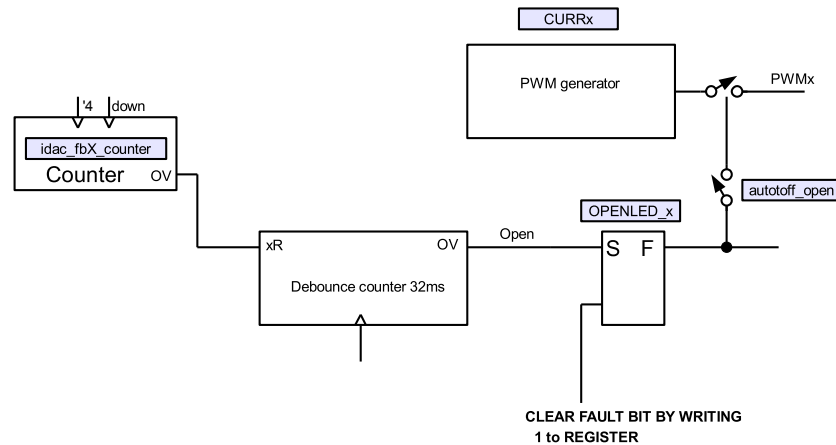

Figure 8.2 : Open LED Detection

8.1.5 Short LED Detection

Short LED detection is implemented in two different ways:

1. With a built-in self-test (Short-BIST) circuit.
2. With two comparator inputs for monitoring external voltages (Short-COMP).

The external voltage is divided by an external resistor and an internal current source. The output of the comparators only takes effect if all selected PWM-signals are “1” for a minimum time of “Tshortmin” at the same time. The selection of Short1 or Short2 Group is done by “fb_ON_x” and “fb_sel_X”.

16-Channel White LED Controller for LCD Backlight

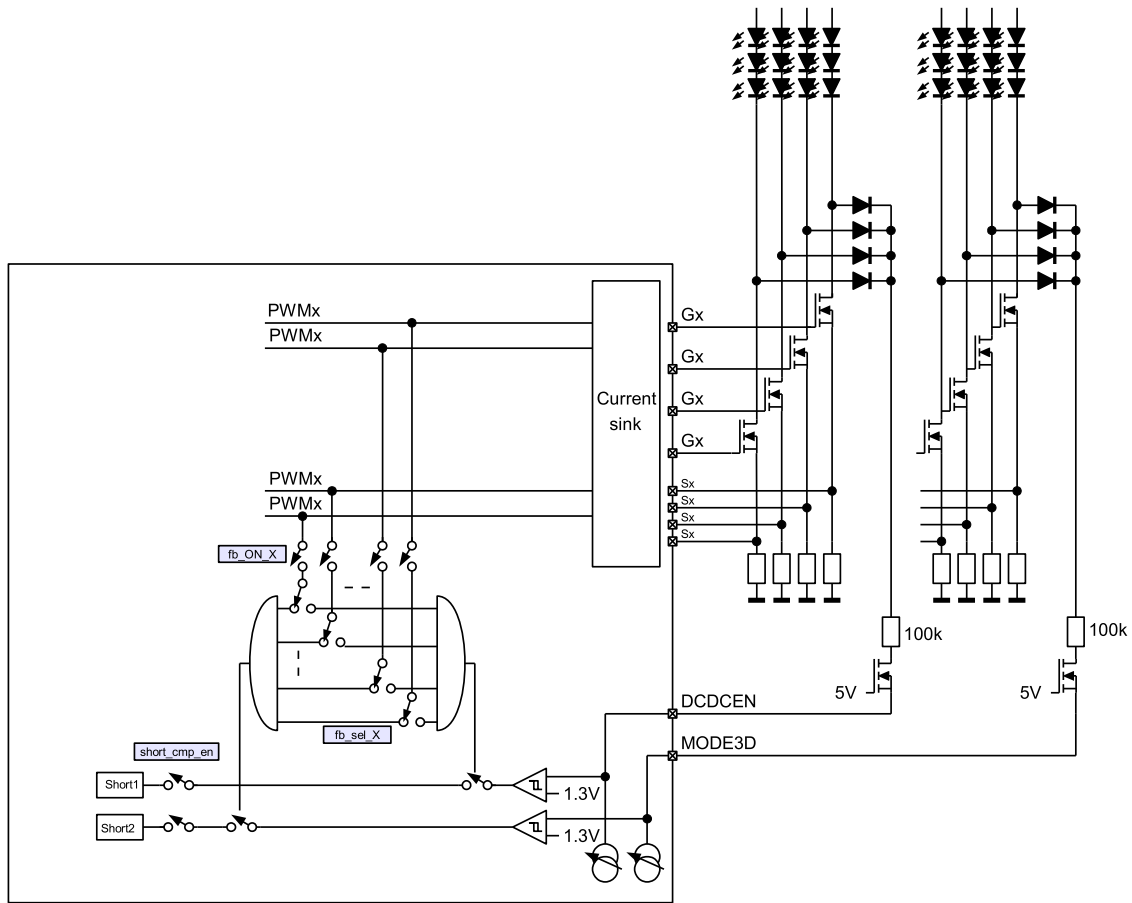

Figure 8.3 : Short-COMP Block Diagram

8.1.6 DAC

The reference voltage for the output stage is generated by an internal 10-bit DAC. The DAC reference can be selected between 500mV and 800mV depending on register settings. The DAC is trimmed during production with $DAC_{ref} = 800mV/VDAC = 250mV$ and $DAQ_{ref} = 500mV/VDAC = 250mV$ to guarantee an output current accuracy of $\pm 0.5\%$ on every current output.

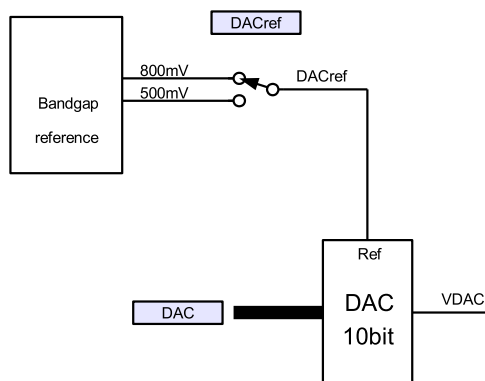

Figure 8.4 : DAC and DAC Reference Generation

16-Channel White LED Controller for LCD Backlight

The DAC output voltage can be calculated with:

$$VDAC = \frac{DAC_{ref}}{1024} \times DAC$$

DAC...10-bit data value

DAC_{ref}...DAC reference voltage 500mV or 800mV

8.1.7 Registers in Current Output Stage

The access mode explanation is as follows:

R:	Read only
RW, R/W:	Read and write
RWL:	Read and write with lock
ACS_WC:	Auto clear and set, write clear
RW_AC:	Read and write, auto clear
RW_AS:	Read and write, auto set
R/WC:	Read and write clear
PUSH:	Write

Addr: 0x01		CUR_ON_1		
Bit	Bit Name	Default	Access	Bit Description
7:0	CURR1 - CURR8	00000000	RW_AC	Enables or disables current outputs. 0: Output OFF 1: Output ON

Table 1: CUR_ON_1

Addr: 0x02		CUR_ON_2		
Bit	Bit Name	Default	Access	Bit Description
7:0	CURR9 - CURR16	00000000	RW_AC	Enables or disables current outputs. 0: Output OFF 1: Output ON

Table 2: CUR_ON_2

16-Channel White LED Controller for LCD Backlight

Addr: 0x03		Fault_1		
Bit	Bit Name	Default	Access	Bit Description
7	Autotoff_uv	1	RW	1...Undervoltage lockout: If VDD < VDD_UVL channels are turned OFF by resetting CURRx-bits
6	Short_bist_en	0	RW_AC	1...Starts built-in self-test (BIST) for short detection. Bit is cleared after BIST has finished
5:4	Short_cmp_en	00	RW	Short detection with comparators: Not available in LQFP44 00...OFF 01...Enables short comp 1 10...Enables short comp 2 11...Enables short comp 1 and comp 2
3	Retrial_open	0	RW	1... Retrial open detection after autotoff_open was triggered
2	Autotoff_ot	1	RW	Automatic output turn OFF at overtemperature 0... Do not turn OFF current outputs on overtemperature 1... Turn OFF current outputs on overtemperature
1	Open_en	0	RW	1... Enable open LED detection for all channels
0	Autotoff_open	0	RW	Automatic feedback turn OFF on open LED detection 0... Do not turn OFF feedback on open LED detection 1... Turn OFF feedback on open LED detection

Table 3: Fault_1

16-Channel White LED Controller for LCD Backlight

Addr: 0x04		GPIO_CTRL		
Bit	Bit Name	Default	Access	Bit Description
7:6	xFAULT_config	0	RW	Output configuration pin xFAULT: 00...Open Drain 01...Push/Pull 10...Hi-Z, input only 11...No effect
5:4	Mode3D_config	0	RW	Output configuration pin Mode3D: 00...Open Drain 01...Push/Pull 10...Hi-Z, input only, SHORT COMP 2 INPUT enabled 11...No effect
3	Mode3D	0	RW	0...Pin Mode3D = 0 1...Pin Mode3D = 1
2:1	DCDCEN_config	0	RW	Output configuration pin DCDCEN: 00...Open Drain 01...Push/Pull 10...Hi-Z, input only, SHORT COMP 1 INPUT enabled 11...No effect
0	DCDCEN	0	RW	0...Pin DCDCEN = 0 1...Pin DCDCEN = 1

Table 4: FB_SEL1

Addr: 0x05		FB_SEL1		
Bit	Bit Name	Default	Access	Bit Description
7:0	Fb_sel_1 – Fb_sel_8	00000000	RW	Select FB-channel for current outputs 1 to 8 0...Select FB channel FB1 and short-comparator group 1 1...Select FB channel FB2 and short-comparator group 2

Table 5: FB_SEL1

Addr: 0x06		FB_SEL2		
Bit	Bit Name	Default	Access	Bit Description
7:0	Fb_sel_9 – Fb_sel_16	00000000	RW	Select FB-channel for current outputs 9 to 16 0...Select FB channel FB1 and short-comparator group 1 1...Select FB channel FB2 and short-comparator group 2

Table 6: FB_SEL2

16-Channel White LED Controller for LCD Backlight

Addr: 0x07		CURR_CTRL		
Bit	Bit Name	Default	Access	Bit Description
7:6	Sel_ac	00	RW	Do not change
5	Fb_ac_off	0	RW	0...AC feedback enabled 1...AC feedback disabled (external BJT) If lb_comp=1, FB_ac_off = 1 must be set
4	lb_comp	0	RW	0 ...Bias current compensation OFF 1...Bias current compensation ON (external BJT) If lb_comp=1, FB_ac_off = 1 must be set
3	DACref_buffer	0	RW	0...DAC output is buffered 1...DAC output is unbuffered
2	DACref	0	RW	0...DACref = 500mV 1...DACref = 800mV
1:0	Slew_rate	00	RW	Select slew rate of output drivers. (Slew rate of VREF) 00...250mV/16µs 01...250mV/8µs 10...250mV/4µs 11...250mV/2µs

Table 7: CURR_CTRL

Addr: 0x08		SHORTLED_1		
Bit	Bit Name	Default	Access	Bit Description
7:0	SHORTLED_1 – SHORTLED_8	00000000	R/WC	Indicates short LED found with BIST on outputs 1 to 8 0...No short LED detected 1... Short LED detected

Table 8: SHORTLED_1

Addr: 0x09		SHORTLED_2		
Bit	Bit Name	Default	Access	Bit Description
7:0	SHORTLED_9 – SHORTLED_16	00000000	R/WC	Indicates short LED found with BIST on outputs 9 to 16 0...No short LED detected 1... Short LED detected

Table 9: SHORTLED_2

16-Channel White LED Controller for LCD Backlight

Addr: 0x0A		OPENLED_1		
Bit	Bit Name	Default	Access	Bit Description
7:0	OPENLED_1 – OPENLED_8	00000000	AS/WC	Indicates open LED condition on outputs 1 to 8 0...No open LED detected 1... Open LED detected

Table 10: OPENLED_1

Addr: 0x0B		OPENLED_2		
Bit	Bit Name	Default	Access	Bit Description
7:0	OPENLED_9 – OPENLED_16	00000000	AS/WC	Indicates open LED condition on outputs 9 to 16 0...No open LED detected 1... Open LED detected

Table 11: OPENLED_2

Addr: 0x0E		FB_ON_1		
Bit	Bit Name	Default	Access	Bit Description
7:0	FB_CURR_1 – FB_CURR_8	00000000	RW	Enables or disables feedback function of output channels 0...No feedback function on CURRx 1... Function on CURRx

Table 12: FB_ON_1

Addr: 0x0F		FB_ON_2		
Bit	Bit Name	Default	Access	Bit Description
7:0	FB_CURR_9 – FB_CURR_16	00000000	RW	Enables or disables feedback function of output channels 0...No feedback function on CURRx 1... Function on CURRx

Table 13: FB_ON_2

Addr: 0x0C	Addr: 0x0D	VDAC_H / VDAC_L		
Bit	Bit	Default	Access	Bit Description
7:0	1:0	0X80, 0X00	RW	DAC input [9:0]

Table 14: VDAC_H / VDAC_L

16-Channel White LED Controller for LCD Backlight

Addr: 0x10		IDAC_FB1_COUNTER		
Bit	Bit Name	Default	Access	Bit Description
7:0	IDAC_FB1_COUNTER	00000000	RW	Feedback 1 counter value. Can be overwritten if Fb_cnt_man_fb1 = 1 0x00... FB-current 0µA 0xFF... FB-current 255µA

Table 15: IDAC_FB1_COUNTER

Addr: 0x11		IDAC_FB2_COUNTER		
Bit	Bit Name	Default	Access	Bit Description
7:0	IDAC_FB2_COUNTER	00000000	RW	Feedback 1 counter value. Can be overwritten if Fb_cnt_man_fb2 = 1 0x00... FB-current 0µA 0xFF... FB-current 255µA

Table 16: IDAC_FB2_COUNTER

Addr: 0x12		FBLOOP_CTRL		
Bit	Bit Name	Default	Access	Bit Description
7:6	Vtrip	00	RW	Select gate trip voltage for feedback 00...5*(VDD/6) 01... 4*(VDD/6) 10... 3*(VDD/6) 11... 2*(VDD/6)
5	Fb_cnt_man_fb2	0	RW	0...FB2 counter runs automatically in feedback loop 1...FB2 counter is set manual
4	Fb_cnt_man_fb1	0	RW	0...FB1 counter runs automatically in feedback loop 1...FB1 counter is set manual
3:2	Fbcount_dn_time	01	RW	FB1 and FB2 counter down counting clock cycle ⁽¹⁾ 00...512µs 01...2048µs 10...4096µs 11...8192µs
1:0	Fbcount_up_time	01	RW	FB1 and FB2 counter up counting clock cycle 00...1024µs 01... 256µs 10... 64µs 11... 16µs

Note 1. Down counting starts after 200ms delay time.

Table 17: FBLOOP_CTRL

16-Channel White LED Controller for LCD Backlight

Addr: 0x60		STATUS		
Bit	Bit Name	Default	Access	Bit Description
7	STAT novsync	0	R	1...Indicates missing Vsync signal for longer than 100ms
6	STAT OT	0	R	1...Indicates Overtemperature fault happened
5	STAT Open	0	R	1...Indicates open detection fault happened
4	Short_bist	0	R	1...Indicates a short bist interrupt
3	Vcnt underflow	0	AS_WC	1...VSYNC signal to fast
2	Short2	0	AS_WC	1...Indicates short on channel group 2
1	Short1	0	AS_WC	1...Indicates short on channel group 1
0	Power_good	0	R	1...Power good. Indicates that VDD is greater than VDD_UVL

Table 18: STATUS

Addr: 0x63		SHORT_BIST_CTRL1		
Bit	Bit Name	Default	Access	Bit Description
7:5		000	R	Do not change
4	BIST_retrial	0	RW	0...No BIST retrial 1...Short BIST retrial after 1 second
3	BIST_steptime	0	RW	BIST counter step down time 0...64µs/step 1...128µs/step
2	Autotoff_BIST	0	RW	1...Shorted channels found by BIST are turned OFF
1:0	BIST_wait	0	RW	Wait after max step down value of counter is reached ⁽¹⁾ 00...No wait 01...Wait 1 VSYNC pulse 10...Wait 2 VSYNC pulses 11...Wait 3 VSYNC pulses

Note 1. This option is necessary for phase shifted PWM. To ensure each channel is tested.

Table 19: SHORT_BIST_CTRL1

Addr: 0x64		SHORT_BIST_MAXSTEP		
Bit	Bit Name	Default	Access	Bit Description
7:0	BISTmaxstep	11111111	RW	Maximum down-counts of IDAC counter during BIST

Table 20: SHORT_BIST_MAXSTEP

16-Channel White LED Controller for LCD Backlight

Addr: 0x65		SHORT_BIST_CTRL2		
Bit	Bit Name	Default	Access	Bit Description
7:6		00	R	Do not change
5	COMP_retrial	0	RW	0...No COMP retri 1...Short COMP retri after 1 second
4	Autotoff_COMP	0	RW	1...Shorted channels found by COMP are turned OFF
3:0	COMP_LEVEL	1010	RW	Short detection voltage based on external 100k resistor 0000...2V 0001...3V 0010...4V 0011...5V 0100...6V 0101...7V 0110...8V 0111...9V 1000...10V 1001...11V 1010...12V 1011...13V 1100...13V 1101...13V 1110...13V 1111...13V

Table 21: SHORT_BIST_CTRL2

Addr: 0x6C		COMPREG_1		
Bit	Bit Name	Default	Access	Bit Description
7:0	CompReg1 – CompReg8	00000000	AS/AR	Status of trip comparator

Table 22: COMPREG_1

Addr: 0x6D		COMPREG_2		
Bit	Bit Name	Default	Access	Bit Description
7:0	CompReg9 – CompReg16	00000000	AS/AR	Status of trip comparator

Table 23: COMPREG_2

16-Channel White LED Controller for LCD Backlight

8.2 PWM Generators

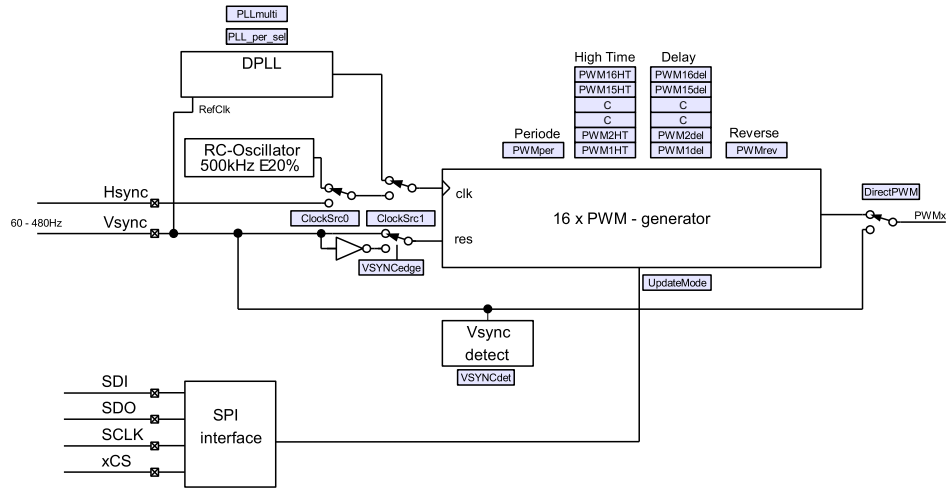

Figure 8.5 : PWM Generators

8.2.1 Clock and Reset

The clock for the built-in PWM generators can be one of the three different sources listed below:

- Internal RC oscillator with 500kHz
- External clock signal. This is usually the HSYNC signal of the TV
- Digital PLL (DPLL) clock derived from VSYNC

8.2.2 Digital PLL

A DPLL can be used to generate the PWM generator counter clock with a frequency that is a multiple of the VSYNC frequency. The frequency multiplication factor can be controlled to be either “PWMperiod” or “PLLmulti” by control bit “PLL_per_sel”.

By default “PLL_per_sel”=“0” to control the frequency by “PWMperiod” which also defines the period for the PWM generators.

If necessary, control bit “PLL_per_sel” can be set to control the frequency multiplication by register “PLLmulti” with 16-bit resolution and independently of PWMperiod.

PLL_per_sel=0 (default):

$$f_{DPLLout} = f_{VSYNC} \times PWM_{period}$$

PLL_per_sel=1:

$$f_{DPLLout} = f_{VSYNC} \times PLLmulti$$

The VSYNC frequency is determined by measuring the VSYNC period with an internal clock. Since the internal clock and the external VSYNC signal are asynchronous, the result of the measurement will jitter by one internal clock cycle. Therefore the generated DPLL-frequency jitters by one clock cycle.

16-Channel White LED Controller for LCD Backlight

In order to prevent starting of a new PWM-period at the end of the current PWM-period due to this jitter it is recommended to use the following setting:

- Set PLL_per_sel=1
- Set PLLmulti = PWMperiod -1

By either changing the input frequency at VSYNC or by changing the divider setting the DPLL will need up to 4 VSYNC cycles to settle to the new value.

If $f_{VSYNC} > 8MHz/PLLmulti$, the bit V_{CNT} is set and a fault is indicated.

8.2.3 PWM Counter

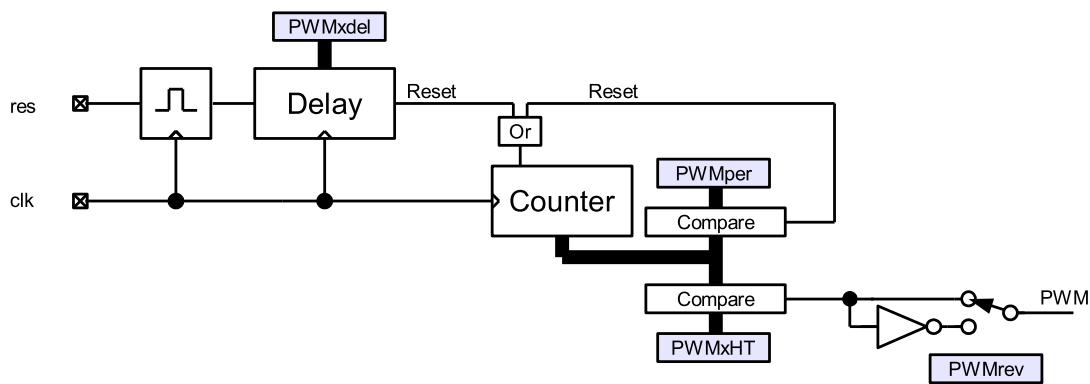

Figure 8.6 : PWM Counter

Each PWM-generator is build with a 13bit counter and digital comparators. The counter is counting up with tclk until the value stored in “PWMper” is reached. This resets the counter and starts the next period. While the counter value is below “PWMxHT” the PWM-signal is “1”, the rest of the period the PWM-signal is “0”. The output of each PWM-generator can also be inverted by means of the “PWMrev”.

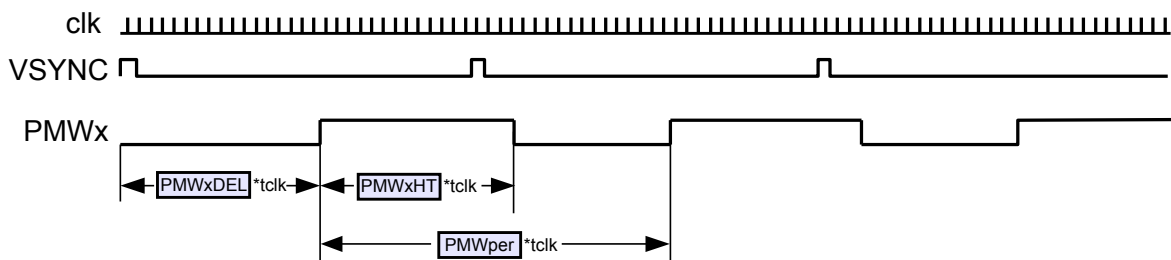

Figure 8.7 : PWMx, VSYNC and CLK Timing Diagram

8.2.4 SPI Data Update, UPDATEmode Bit

The PWM-settings that are programmed via the SPI-Interface take effect depending on the status of the “UPDATEmode”-bit.

If UPDATEmode = 1 new data from the serial interface are stored at the next rising edge of VSYNC.

16-Channel White LED Controller for LCD Backlight

If UPDATEmode = 0 new data from the serial interface are store immediately after xCS goes high and will take effect after current PWM cycle is finished. In this mode the values in the PWMxdel registers are ignored. There will be no Delay on the PWM signals.

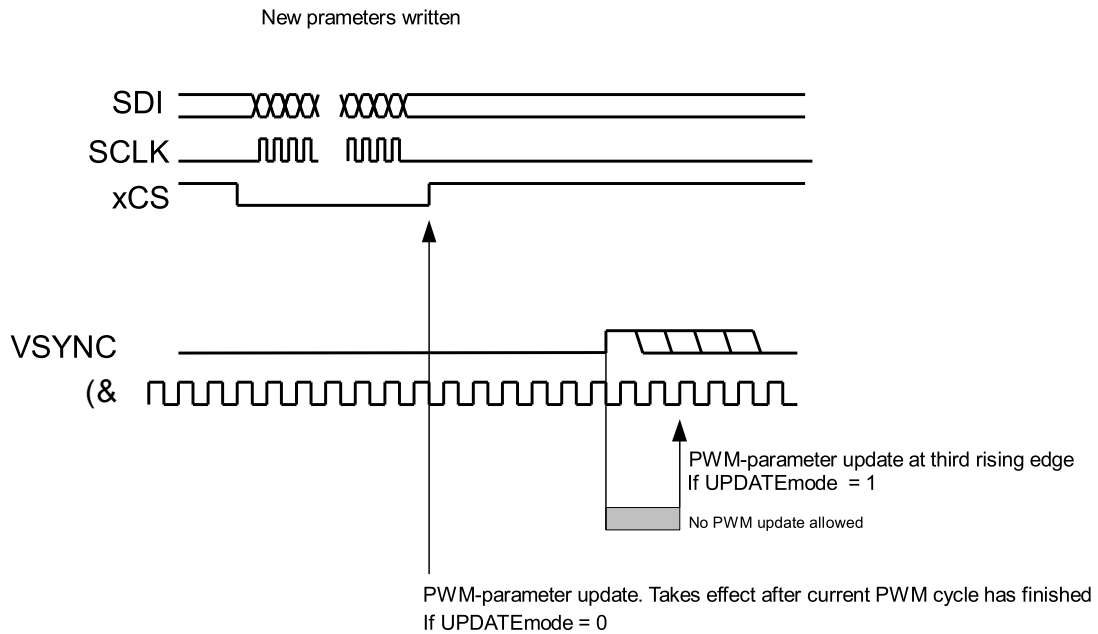

Figure 8.8 : UPDATE mode

The PWMxHT-values are double buffered. HighTime values for the next VSYNC can be written even when the current HighTime is not finished.

Within the first two HSYNC pulses after rising VSYNC no SPI data transfer is allowed.

8.2.5 Direct PWM Mode

The internal signals PWMx can also be direct applied at the VSYNC input if the bit Direct_PWM = 1.

In this mode the default driver has the following configuration:

- All current outputs are ON
- All feedback controls are enabled and connected to FB1
- Open LED detection is enabled
- Open LED detection auto turn OFF function is enabled
- Open LED detection retrial function is enabled
- Short LED detection (Short-COMP) is enabled
- Short LED detection auto turn OFF function is enabled
- Undervoltage lockout and overtemperature detection are enabled

In this mode the device starts with default settings and can still be programmed via SPI.

16-Channel White LED Controller for LCD Backlight

8.2.6 VSYNC Detect

If the bit "VSYNCdet" is set (Register "PWM_CTRL") the VSYNC detector monitors the presence of a VSYNC signal.

If the VSYNC signal is missing for more than 100ms the following changes are done:

- In Register "STATUS" the bit "STAT novsync" is set
- Output xFAULT is acitivated (LOW)
- Current outputs are turned OFF. All register settings remain while the outputs are turned OFF

If the VSYNC signal is applied again the following changes are done:

- In Register "STATUS" the bit "STAT novsync" is reset
- Output xFAULT is deactivated
- Current outputs are turned ON

8.2.7 VSYNC Duration

Since the VSYNC input is connected to an edge detector, there is no restriction on the duration of the VSYNC pulse.

16-Channel White LED Controller for LCD Backlight

8.3 Registers in PWM Generators

RegAddr: 0x13		PWM_CTRL		
7	PLL_per_sel	0	RW	DPLL frequency generation 0...DPLL-period = Vsync*PWMperiod 1...DPLL-period = Vsync*PLLmulti
6	ClockSrc1	0	RW	Clock source for internal PWM-generators 0...Internal RC oscillator or HSYNC (depending on ClockSrc0) 1...PLL output
5	Pwm_rev	0	RW	0...Normal PWM operation 1...PWM signals are inverted
4	VSYNCdet	0	RW_AS	Enable VSYNC detection 0...VSYNC-detection OFF 1... VSYNC-detection ON. All current outputs are turned OFF if VSYNC signal is missing for 100ms
3	VSYNCedge	0	RW	Defines VSYNC trigger edge 0...VSYNC trigger on rising edge 1...VSYNC trigger on falling edge
2	Direct_PWM	0	RW_AS	Select external or internal PWM signal 0...PWM signal is generated internally 1...PWM signal is applied externally at pin VSYNC Factory trim bit is read during startup. See section Direct PWM Mode
1	Update_Mode	0	RW	Defines when internal registers are updated 0...Registers updated with rising edge of xCS 1...Registers updated with next VSYNC-edge
0	ClockSrc0	0	RW	Clock source for internal PWM-generators 0...Internal RC oscillator 1...External Pin HSYNC See Note 1

Note 1. This bit only takes effect when ClockSrc1 = 0.

Table 24: PWM_CTRL

RegAddr: 0x15	RegAddr: 0x14	PWMperiod		
Bit	Bit	Default	Access	Bit Description
4:0	7:0	0x00, 0x00	RW	PWMper[12:0] sets PWM period

Table 25: PWMperiod

RegAddr: 0x17	RegAddr: 0x16	PWM1delay		
Bit	Bit	Default	Access	Bit Description
3:0	7:0	0x00, 0x00	RW	PWM1per[11:0] sets PWM1 delay

Table 26: PWM1delay

16-Channel White LED Controller for LCD Backlight

RegAddr: 0x19	RegAddr: 0x18	PWM2delay		
Bit	Bit	Default	Access	Bit Description
3:0	7:0	0x00, 0x00	RW	PWM2per[11:0] sets PWM2 delay

Table 27: PWM2delay

RegAddr: 0x1B	RegAddr: 0x1A	PWM3delay		
Bit	Bit	Default	Access	Bit Description
3:0	7:0	0x00, 0x00	RW	PWM3per[11:0] sets PWM3 delay

Table 28: PWM3delay

RegAddr: 0x1D	RegAddr: 0x1C	PWM4delay		
Bit	Bit	Default	Access	Bit Description
3:0	7:0	0x00, 0x00	RW	PWM4per[11:0] sets PWM4 delay

Table 29: PWM4delay

RegAddr: 0x1F	RegAddr: 0x1E	PWM5delay		
Bit	Bit	Default	Access	Bit Description
3:0	7:0	0x00, 0x00	RW	PWM5per[11:0] sets PWM5 delay

Table 30: PWM5delay

RegAddr: 0x21	RegAddr: 0x20	PWM6delay		
Bit	Bit	Default	Access	Bit Description
3:0	7:0	0x00, 0x00	RW	PWM6per[11:0] sets PWM6 delay

Table 31: PWM6delay

RegAddr: 0x23	RegAddr: 0x22	PWM7delay		
Bit	Bit	Default	Access	Bit Description
3:0	7:0	0x00, 0x00	RW	PWM7per[11:0] sets PWM7 delay

Table 32: PWM7delay

RegAddr: 0x25	RegAddr: 0x24	PWM8delay		
Bit	Bit	Default	Access	Bit Description
3:0	7:0	0x00, 0x00	RW	PWM8per[11:0] sets PWM8 delay

Table 33: PWM8delay

16-Channel White LED Controller for LCD Backlight

RegAddr: 0x27	RegAddr: 0x26	PWM9delay		
Bit	Bit	Default	Access	Bit Description
3:0	7:0	0x00, 0x00	RW	PWM9per[11:0] sets PWM9 delay

Table 34: PWM9delay

RegAddr: 0x29	RegAddr: 0x28	PWM10delay		
Bit	Bit	Default	Access	Bit Description
3:0	7:0	0x00, 0x00	RW	PWM10per[11:0] sets PWM10 delay

Table 35: PWM10delay

RegAddr: 0x2B	RegAddr: 0x2A	PWM11delay		
Bit	Bit	Default	Access	Bit Description
3:0	7:0	0x00, 0x00	RW	PWM11per[11:0] sets PWM11 delay

Table 36: PWM11delay

RegAddr: 0x2D	RegAddr: 0x2C	PWM12delay		
Bit	Bit	Default	Access	Bit Description
3:0	7:0	0x00, 0x00	RW	PWM12per[11:0] sets PWM12 delay

Table 37: PWM12delay

RegAddr: 0x2F	RegAddr: 0x2E	PWM13delay		
Bit	Bit	Default	Access	Bit Description
3:0	7:0	0x00, 0x00	RW	PWM13per[11:0] sets PWM13 delay

Table 38: PWM13delay

RegAddr: 0x31	RegAddr: 0x30	PWM14delay		
Bit	Bit	Default	Access	Bit Description
3:0	7:0	0x00, 0x00	RW	PWM14per[11:0] sets PWM14 delay

Table 39: PWM14delay

RegAddr: 0x33	RegAddr: 0x32	PWM15delay		
Bit	Bit	Default	Access	Bit Description
3:0	7:0	0x00, 0x00	RW	PWM15per[11:0] sets PWM15 delay

Table 40: PWM15delay

16-Channel White LED Controller for LCD Backlight

RegAddr: 0x35		RegAddr: 0x34		PWM16delay	
Bit	Bit	Default	Access	Bit Description	
3:0	7:0	0x00, 0x00	RW	PWM16per[11:0] sets PWM16 delay	

Table 41: PWM16delay

RegAddr: 0x36		LOCKUNLOCK			
Bit	Bit Name	Default	Access	Bit Description	
7:0	LOCKUNLOCK	0x00	RW	MagicByte to lock and unlock writing and reading of registers Writing into register: 0xCX...Unlock register Group1. Writing enabled 0xA...Unlock register Group2. Writing enabled 0xCA...Unlock register Group1 and Group2. Writing enabled 0vAX...Lock register Group1. Writing disabled 0vXC...Lock register Group2. Writing disabled 0vAC...Lock register Group1 and Group2. Writing disabled X...Don't care. All other values do not change the status of LOCKUNLOCK. Reading from register: 0x00....Group1 and Group2 are locked 0x01...Group1 is unlocked 0x02...Group2 is unlocked 0x03...Group1 and Group2 are unlocked	

Table 42: LOCKUNLOCK

RegAddr: 0x38		RegAddr: 0x37		PWM1hightime	
Bit	Bit	Default	Access	Bit Description	
3:0	7:0	0x00, 0x00	RW	PWM1HT[11:0] sets PWM1 high time	

Table 43: PWM1hightime

RegAddr: 0x3A		RegAddr: 0x39		PWM2hightime	
Bit	Bit	Default	Access	Bit Description	
3:0	7:0	0x00, 0x00	RW	PWM2HT[11:0] sets PWM2 high time	

Table 44: PWM2hightime

RegAddr: 0x3C		RegAddr: 0x3B		PWM3hightime	
Bit	Bit	Default	Access	Bit Description	
3:0	7:0	0x00, 0x00	RW	PWM3HT[11:0] sets PWM3 high time	

Table 45: PWM3hightime

16-Channel White LED Controller for LCD Backlight

RegAddr: 0x3E	RegAddr: 0x3D	PWM4hightime		
Bit	Bit	Default	Access	Bit Description
3:0	7:0	0x00, 0x00	RW	PWM4HT[11:0] sets PWM4 high time

Table 46: PWM4hightime

RegAddr: 0x40	RegAddr: 0x3F	PWM5hightime		
Bit	Bit	Default	Access	Bit Description
3:0	7:0	0x00, 0x00	RW	PWM5HT[11:0] sets PWM5 high time

Table 47: PWM5hightime

RegAddr: 0x42	RegAddr: 0x41	PWM6hightime		
Bit	Bit	Default	Access	Bit Description
3:0	7:0	0x00, 0x00	RW	PWM6HT[11:0] sets PWM6 high time

Table 48: PWM6hightime

RegAddr: 0x44	RegAddr: 0x43	PWM7hightime		
Bit	Bit	Default	Access	Bit Description
3:0	7:0	0x00, 0x00	RW	PWM7HT[11:0] sets PWM7 high time

Table 49: PWM7hightime

RegAddr: 0x46	RegAddr: 0x45	PWM8hightime		
Bit	Bit	Default	Access	Bit Description
3:0	7:0	0x00, 0x00	RW	PWM8HT[11:0] sets PWM8 high time

Table 50: PWM8hightime

RegAddr: 0x48	RegAddr: 0x47	PWM9hightime		
Bit	Bit	Default	Access	Bit Description
3:0	7:0	0x00, 0x00	RW	PWM9HT[11:0] sets PWM9 high time

Table 51: PWM9hightime

RegAddr: 0x4A	RegAddr: 0x49	PWM10hightime		
Bit	Bit	Default	Access	Bit Description
3:0	7:0	0x00, 0x00	RW	PWM10HT[11:0] sets PWM10 high time

Table 52: PWM10hightime

16-Channel White LED Controller for LCD Backlight

RegAddr: 0x4C	RegAddr: 0x4B	PWM11hightime		
Bit	Bit	Default	Access	Bit Description
3:0	7:0	0x00, 0x00	RW	PWM11HT[11:0] sets PWM11 high time

Table 53: PWM11hightime

RegAddr: 0x4E	RegAddr: 0x4D	PWM12hightime		
Bit	Bit	Default	Access	Bit Description
3:0	7:0	0x00, 0x00	RW	PWM12HT[11:0] sets PWM12 high time

Table 54: PWM12hightime

RegAddr: 0x50	RegAddr: 0x4F	PWM13hightime		
Bit	Bit	Default	Access	Bit Description
3:0	7:0	0x00, 0x00	RW	PWM13HT[11:0] sets PWM13 high time

Table 55: PWM13hightime

RegAddr: 0x52	RegAddr: 0x51	PWM14hightime		
Bit	Bit	Default	Access	Bit Description
3:0	7:0	0x00, 0x00	RW	PWM14HT[11:0] sets PWM14 high time

Table 56: PWM14hightime

RegAddr: 0x54	RegAddr: 0x53	PWM15hightime		
Bit	Bit	Default	Access	Bit Description
3:0	7:0	0x00, 0x00	RW	PWM15HT[11:0] sets PWM15 high time

Table 57: PWM15hightime

RegAddr: 0x56	RegAddr: 0x55	PWM16hightime		
Bit	Bit	Default	Access	Bit Description
3:0	7:0	0x00, 0x00	RW	PWM16HT[11:0] sets PWM16 high time

Table 58: PWM16hightime

16-Channel White LED Controller for LCD Backlight

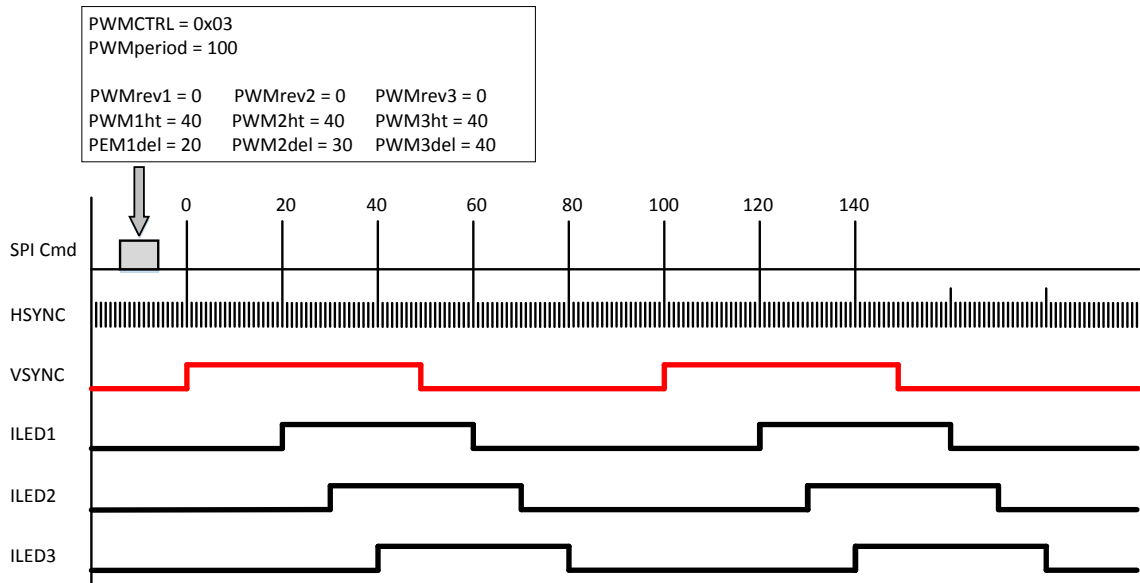

Figure 8.9 : PWM Example 1

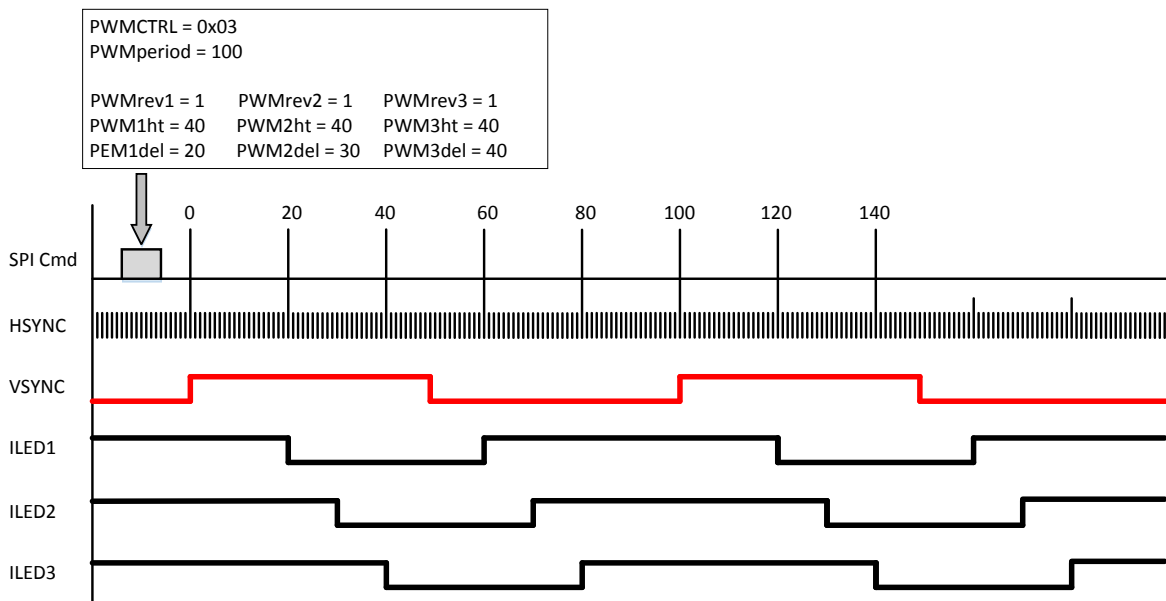

Figure 8.10 : PWM Example 2

16-Channel White LED Controller for LCD Backlight

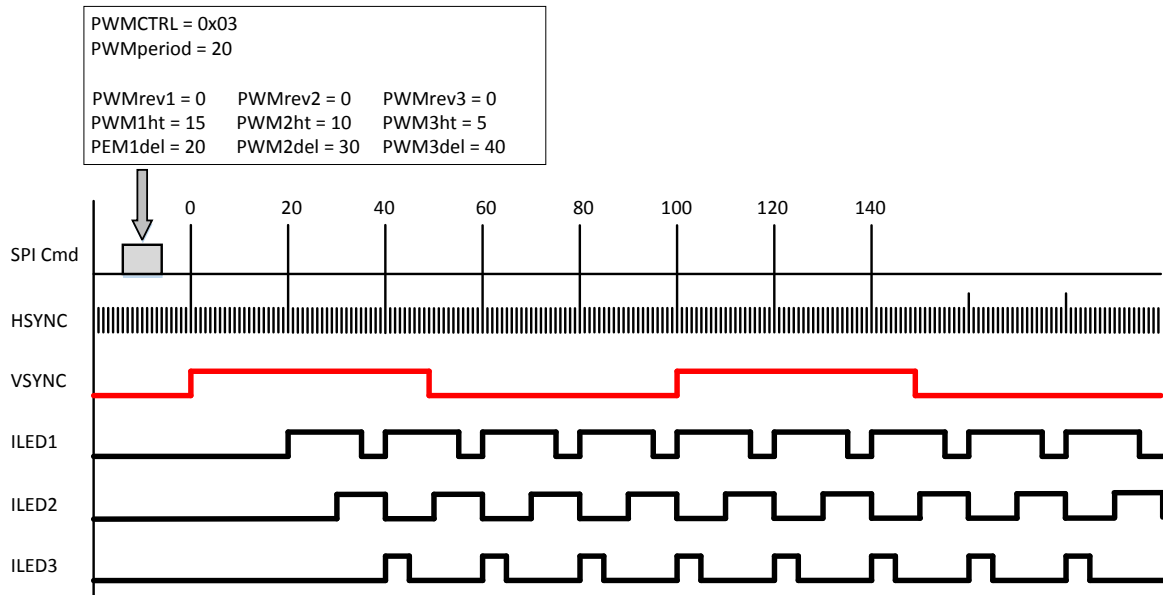

Figure 8.11 : PWM Example 3

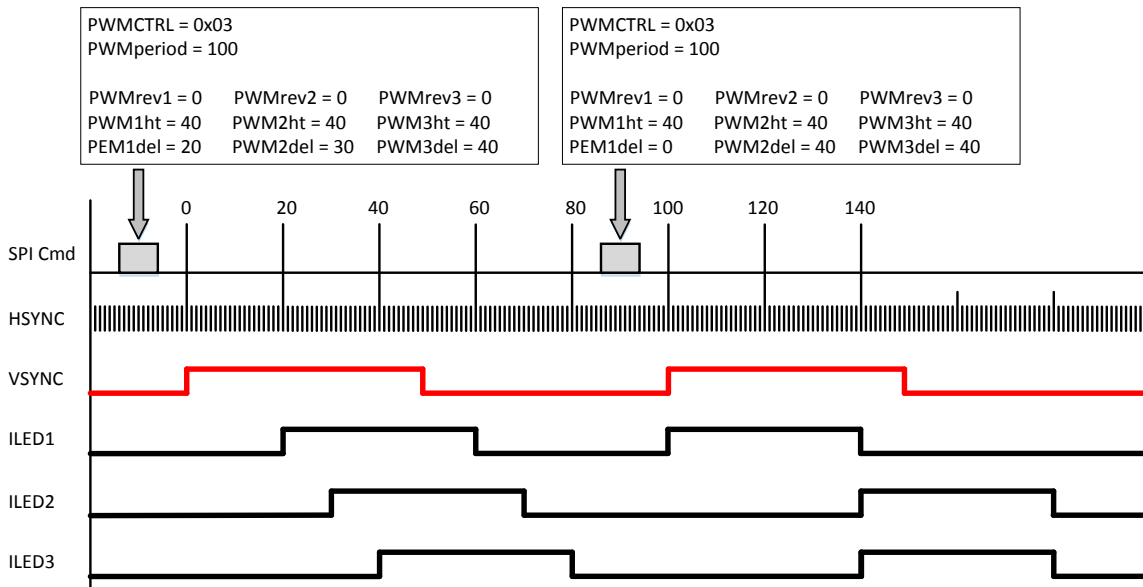

Figure 8.12 : PWM Example 4

16-Channel White LED Controller for LCD Backlight

8.4 Power Supply

8.4.1 Voltage Regulator V3_2

A built in linear voltage regulator provides 3.2V supply voltage for external devices at pin V3_2. A 2.2μF decoupling capacitor should be connected to pin V3_2.

8.4.2 Interface Power Supply V3_2

Pin V3_2 supplies all digital inputs/outputs.

8.5 Safety Features

8.5.1 Temperature Shutdown

If “autotoff_ot” = 1 the outputs of the device are turned OFF when the die temperature reaches 140°C. If the die temperature goes below 130°C the outputs are turned ON again.

8.5.2 Register Lock/Unlock

To prevent wrong writing to registers due to noise on the serial interface a lock/unlock mechanism is implemented.

Register 0x01, 0x02, 0x03, 0x04, 0x05, 0x06, 0x07, 0x0E, 0x0F, 0x10, 0x11, 0x12, 0x13, 0x63, 0x64, 0x65 belong to Group1 and can only be written if Group1 is unlocked by the “LOCKUNLOCK”-byte (Reg: 0x36)

Register 0x0C, 0x0D, 0x14, 0x15, 0x61, 0x62 belong to Group2 and can only be written if Group2 is unlocked by the “LOCKUNLOCK”-byte (Reg: 0x36)

The default value of the Groups is locked.

8.6 Dynamic Feedback Control

The output of pins “FB1” and “FB2” can be used to control any external power supply for best power efficiency.

Every power supply senses its output voltage with a resistive voltage divider. This voltage divider can be modified to set the output voltage between a minimum output voltage VMIN and a maximum output voltage VMAX. The design of the dynamic feedback control is done in 2 steps.

Step 1: Calculate resistors R1 in order to achieve the desired voltage range (VMAX – VMIN) with 255μA maximum current DAC output.

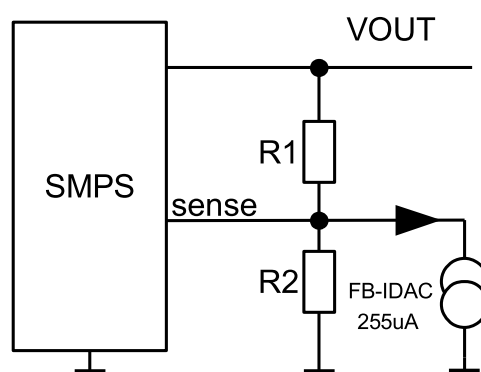

Figure 8.13 : Step 1

$$R1 = \frac{V_{out_{MAX}} - V_{out_{MIN}}}{255\mu A}$$

16-Channel White LED Controller for LCD Backlight

Step 2: Calculate resistor R2 for minimum output voltage with 0μA minimum current DAC output.

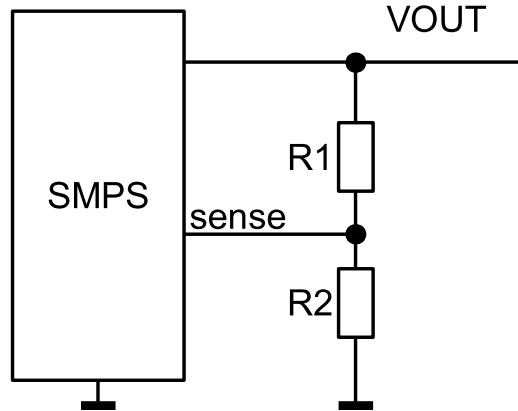

Figure 8.14 : Step 2

$$R2 = \frac{R1}{\left(\frac{V_{out_MIN}}{V_{sense}} - 1\right)}$$

The output voltage V_{OUT} can also be adjusted manually by writing the “idac_FBx_counter” value (“FB_cnt_man_fb”=1). In this case the output voltage can be calculated as follows:

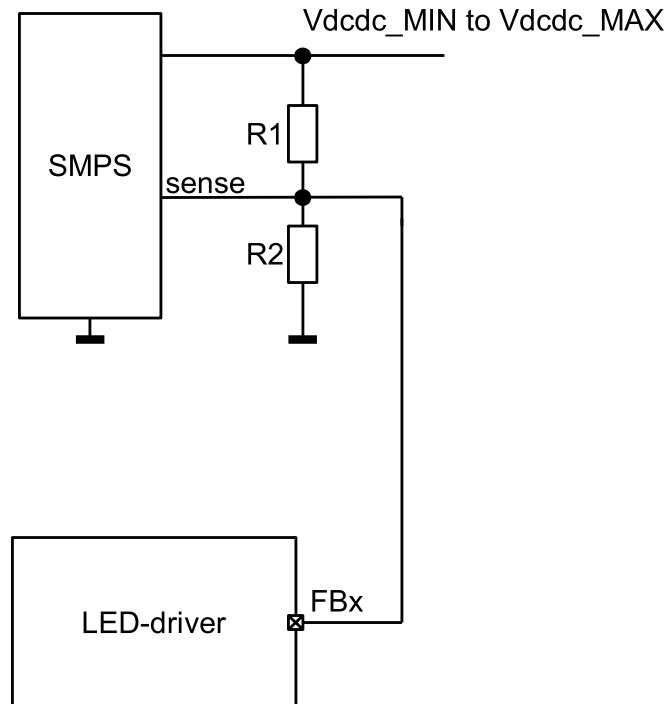

Figure 8.15 : Step 3

16-Channel White LED Controller for LCD Backlight

$$V_{OUT} = \left(1 + \frac{R1}{R2}\right) \times V_{SENSE} + R1 \times \text{"idac_fbx_counter"} \times 1\mu\text{A}$$

Example: $V_{out_MIN} = 60\text{V}$, $V_{out_MAX} = 80\text{V}$, $V_{SENSE} = 1.25\text{V}$

$$R1 = \frac{(V_{out_MAX} - V_{out_MIN})}{255\mu\text{A}} = \frac{(80\text{V} - 60\text{V})}{255\mu\text{A}} = 78\text{k}\Omega$$

$$R2 = \frac{R1}{\left(\frac{V_{out_MIN}}{V_{SENSE}} - 1\right)} = \frac{78\text{k}\Omega}{\left(\frac{60\text{V}}{1.25\text{V}} - 1\right)} = 1.66\text{k}\Omega$$

8.7 GPIO

The two pins DCDCEN and Mode3D can be used to change the configuration of a DC-DC controller. These pins can also be used as general purpose input/output pins which can be configured as high impedance input, Push-Pull output or Open drain output. Also the output pin xFAULT can be configured.

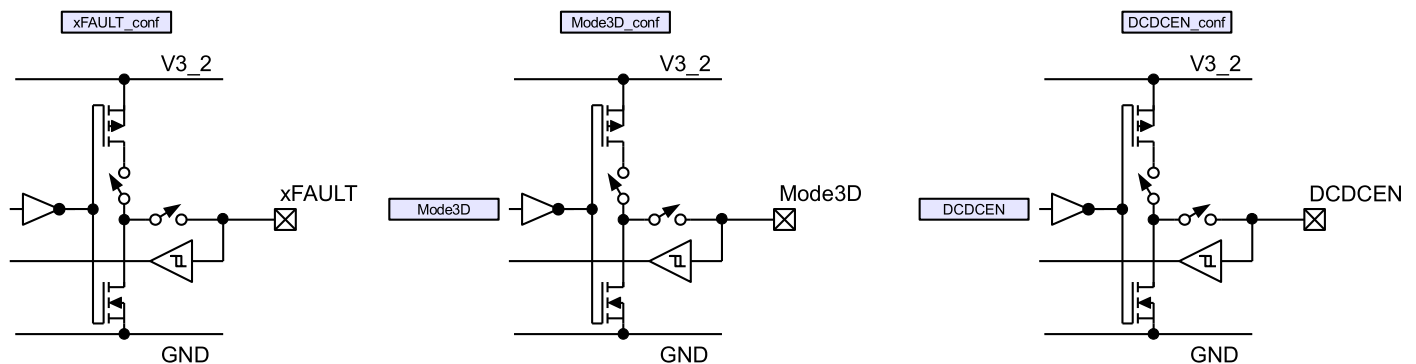

Figure 8.16 : GPIO

8.8 SPI Interface

For the data transfer a serial peripheral interface (SPI) is used. The SPI is configured to work only as SPI slave. If more than one driver is connected to a SPI master, they can be connected in a "Daisy Chain"-structure or a parallel structure.

8.8.1 SPI Daisy Chain Structure

All SPI slaves share the same clock (SCLK) and chip select (xCS) signal. In that configuration all devices can be treated as one big shift register. The devices are automatically enumerated as described in the next section.

16-Channel White LED Controller for LCD Backlight

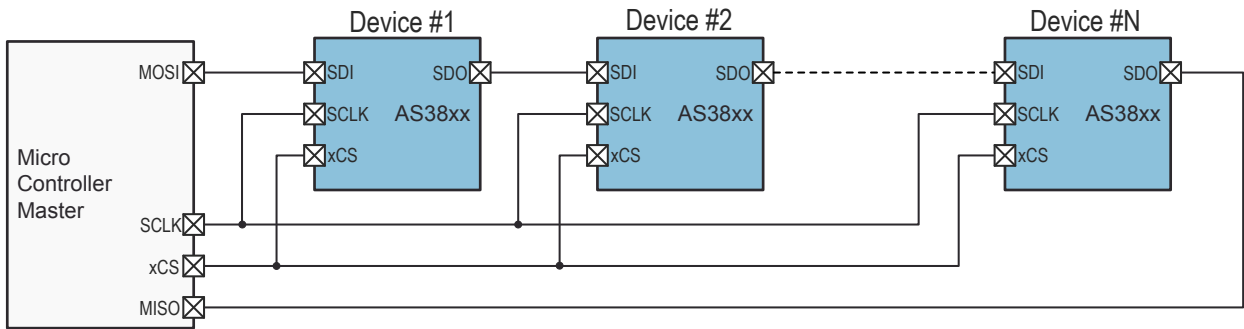

Figure 8.17 : SPI Daisy Chain Structure

8.8.2 SPI Parallel Structure

All SPI slaves share the same input (SDI) output (SDO) and clock (SCLK) signal. Every single device can be addressed via the chip select (xCS) signal. In this configuration every device has the “DevAddr = 0x01”.

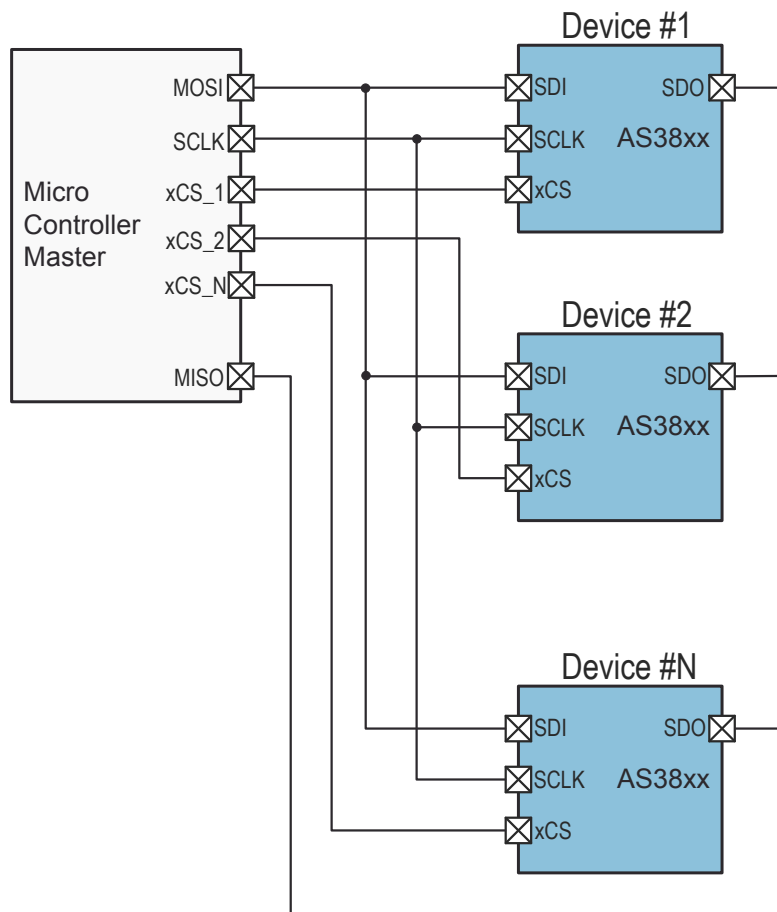

Figure 8.18 : SPI Parallel Structure

16-Channel White LED Controller for LCD Backlight

8.8.3 SPI Device Address Enumeration

The device address of each driver is automatically set by the position of the device in the chain.

The first device has DevAddr = 0x01, the second device has DevAddr = 0x02 and so on. Device Addresses 0x00 and 0x3F are used for special broadcast writing commands described below.

8.8.4 SPI Protocol

Data Types

When xCS=0 all slaves will be activated. The addressing and data section is organized in byte packages. Each message can be built with the following bytes:

B	S	DevAddr[5:0]
---	---	--------------

Addresses a specific driver and defines protocol information

Bit	Meaning	Value
B	Broadcast	B=1...Broadcast message to all devices B=0...Normal message to one single device
S	Singlebyte	S=0...Block data read or write S=1...Single data transmission (only one byte)
DevAddr[5:0]	Device Address	0x00 Write/read same data to same register of all devices (B=1) 0x01 to 0x3E. Device addresses for device 1 to 62 0x3F Write different data to same register of all devices (B=1)

Table 1: Device Address

NrOfdata[7:0]

Defines the number of data bytes in the data frame if S=0

Bit	Meaning	Value
NrOfdata[7:0]	Number of data bytes in frame	0x00 to 0xFF

Table 2: Number of Data

RW	RegAddr[6:0]
----	--------------

Register address to be read or written

Bit	Meaning	Value
RW	Read/Write	RW=0 Write to register address RW=1 Read from register address
RegAddr[6:0]	Select register address	0x00 to 0x60

Table 3: Register Address

16-Channel White LED Controller for LCD Backlight

Data[7:0]		
Bit	Meaning	Value
Data[7:0]	Data	0x00 to 0xFF

Table 4: Data

Timing

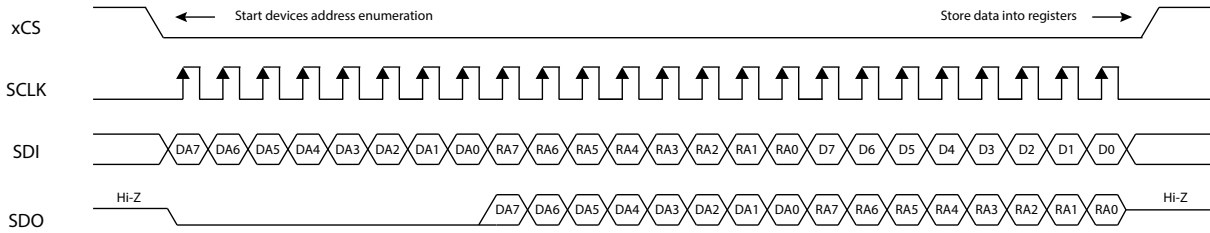

Figure 8.19 : Write Single Data into Single Device

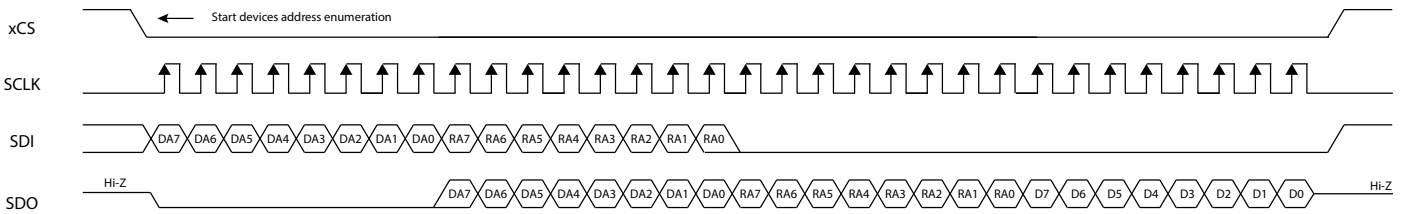

Figure 8.20 : Read Single Data from Single

DA... Device Address

RA... Register Address

D... Data

8.8.5 SPI Protocol Examples

The following drawings show various SPI protocol examples.

Write Single Data

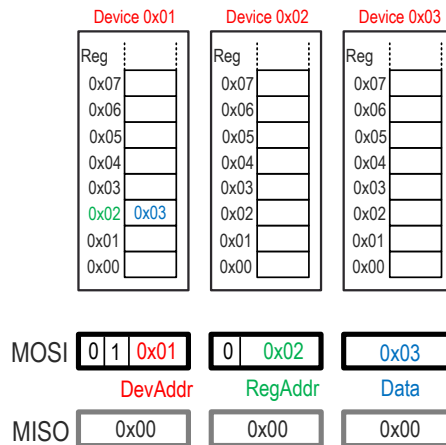

Figure 8.21 : Write to Reg0x02 of Dev0x01

16-Channel White LED Controller for LCD Backlight

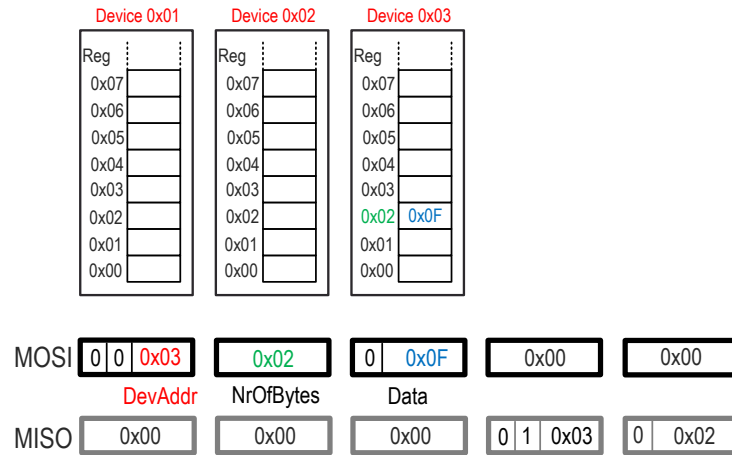

Figure 8.22 : Write to Reg0x02 of Dev0x03

Write N Data

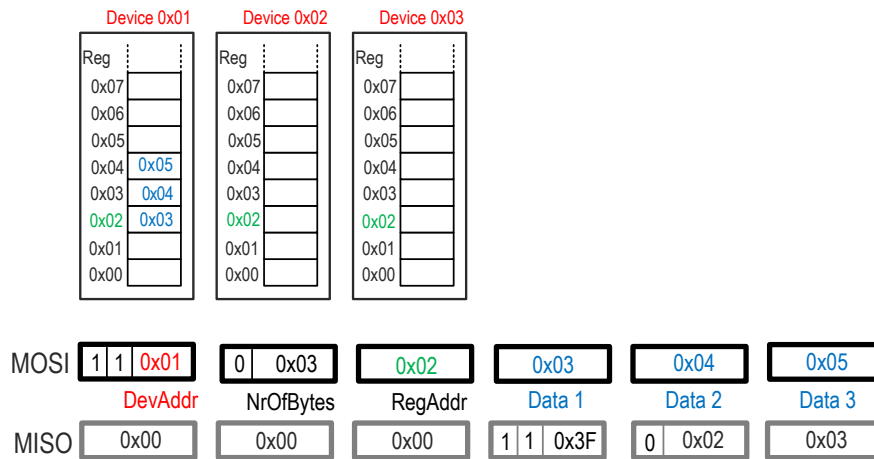

Figure 8.23 : Write to Reg0x02 – Reg0x04 of Dev0x01

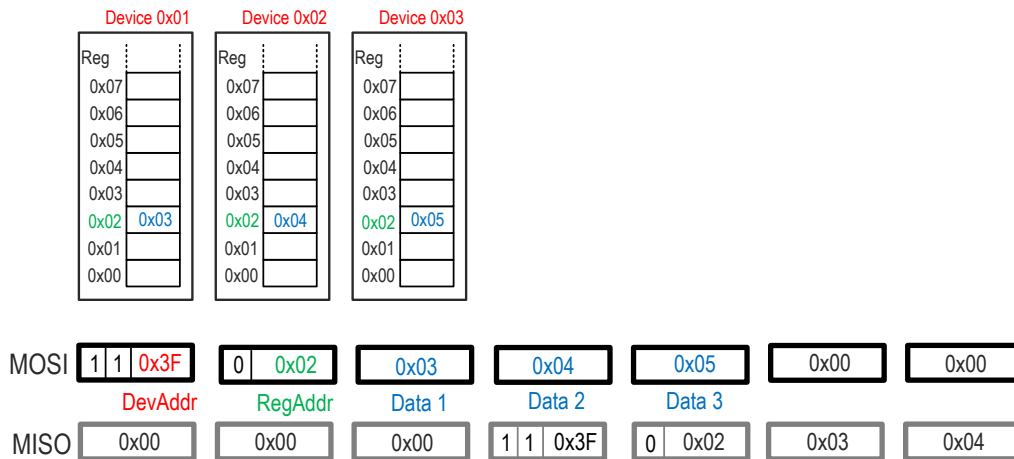

Figure 8.24 : Write to Reg0x02 of Dev0x01 – Dev0x03

16-Channel White LED Controller for LCD Backlight



Figure 8.25 : Write to Reg0x02 – Reg0x03 of Dev0x01 – Dev0x03

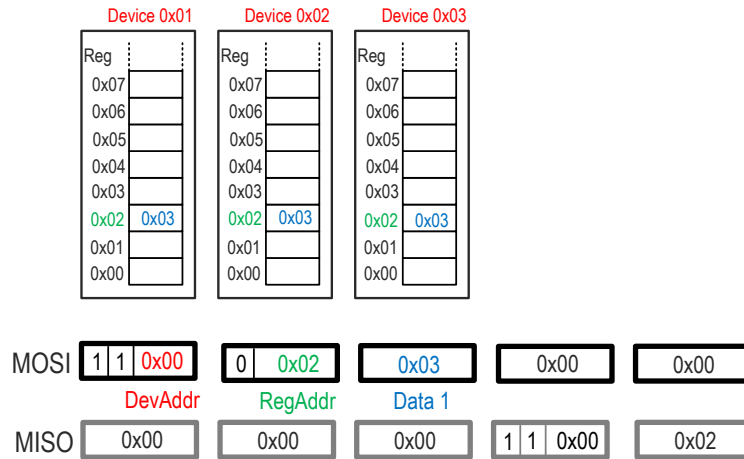

Figure 8.26 : Write to Reg0x02 of Dev0x01 – Dev0x03

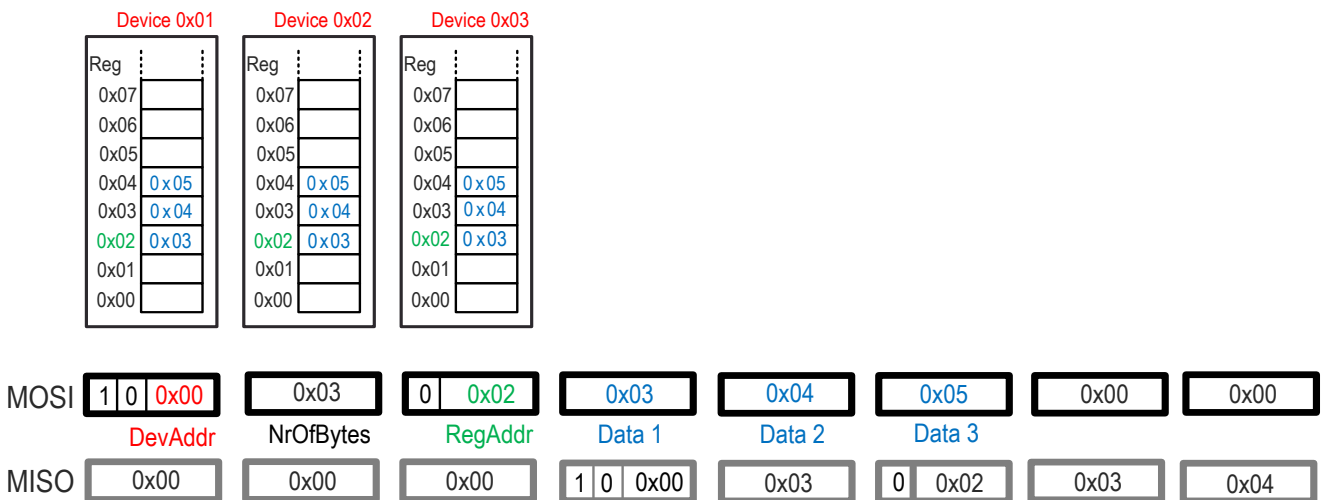

Figure 8.27 : Write to Reg0x02 – Reg0x04 of Dev0x01 – Dev0x03

16-Channel White LED Controller for LCD Backlight

Read Single Data

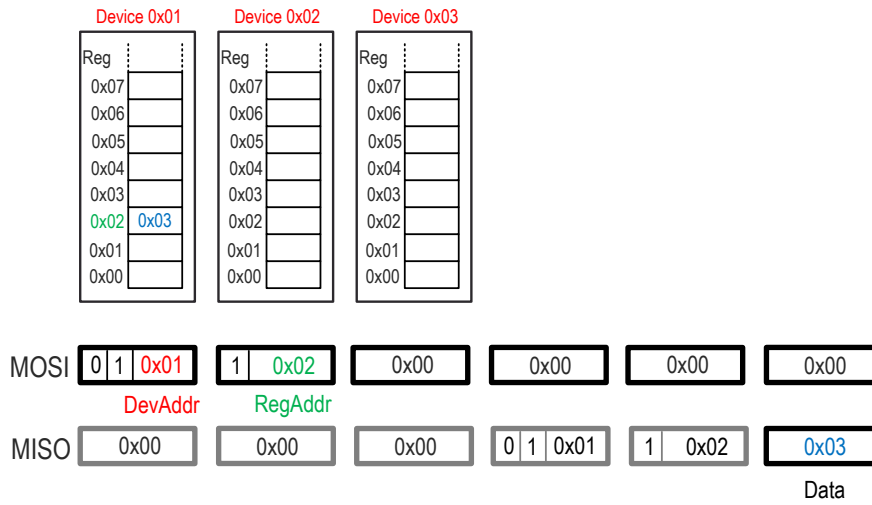

Figure 8.28 : Read from Reg0x02 of Dev0x1

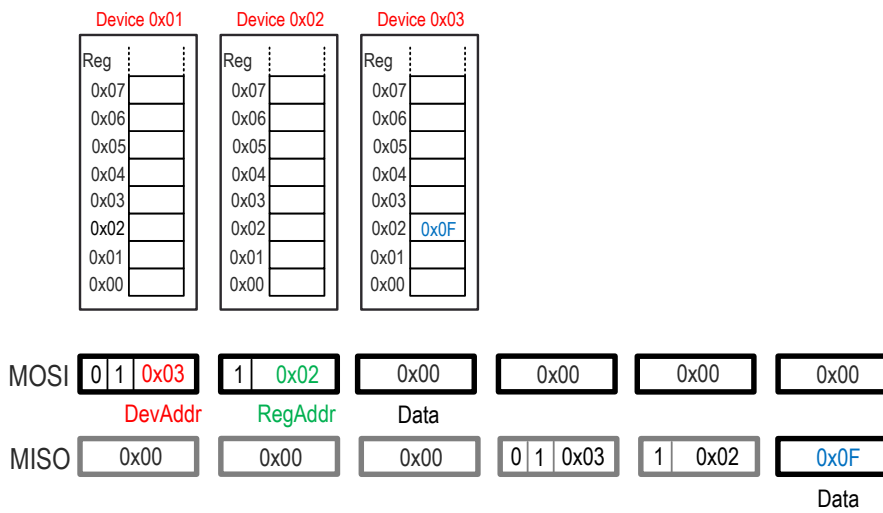

Figure 8.29 : Read from Reg0x02 of Dev0x03

Read N Data

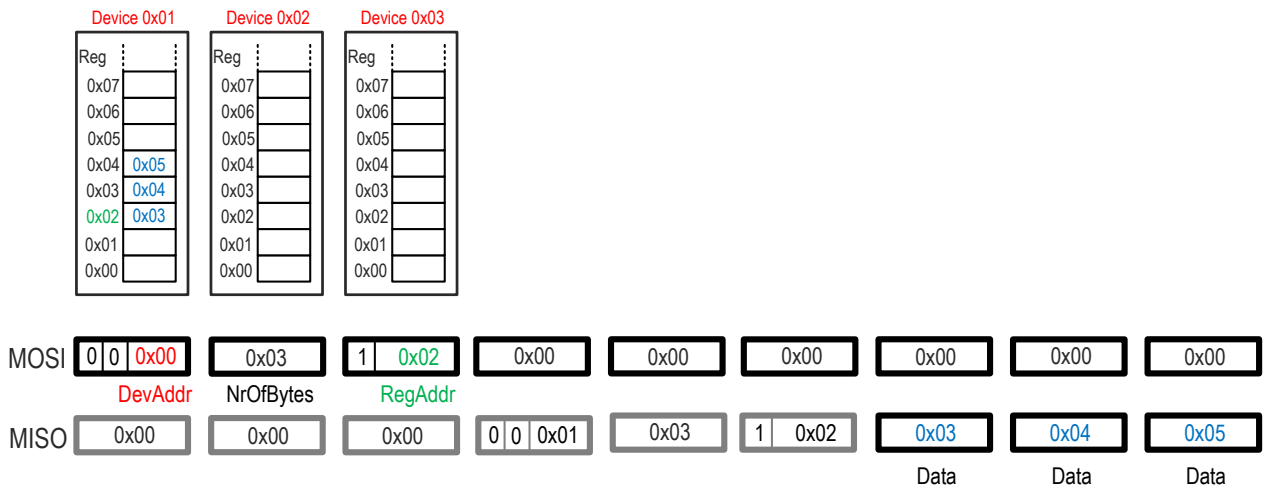

Figure 8.30 : Read from Reg0x02-Reg0x04 of Dev0x03

16-Channel White LED Controller for LCD Backlight

8.9 Timing Characteristics

Parameter	Symbol	Test Conditions	Min	Typ	Max	Unit
SCLK frequency	f_{SCLK}		0		10	MHz
xCS setup time	t1		50			ns
xCS hold time	t2		100			ns
xCS disable time	t3		100			ns
SDI setup time	t4		5			ns
SDI hold time	t5		5			ns
SCLK rise time	t6		5			ns
SCLK fall time	t7		5			ns
SCLK low time	t8		40			ns
SCLK high time	t9		40			ns
Output valid from SCLK low	t10		10			ns
SCLK falling to xCS rising edge	t11		50			ns

8.10 Thermal Characteristics QFN48

The thermal characteristics of the devices were measured at 25°C ambient temperature. The device was mounted on a double sided FR4 PCB with the bottom layer used as cooling area.

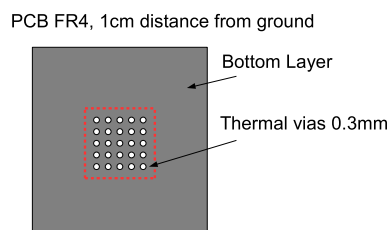

Figure 8.31 : PCB FR4, 1cm Distance from Ground

16-Channel White LED Controller for LCD Backlight

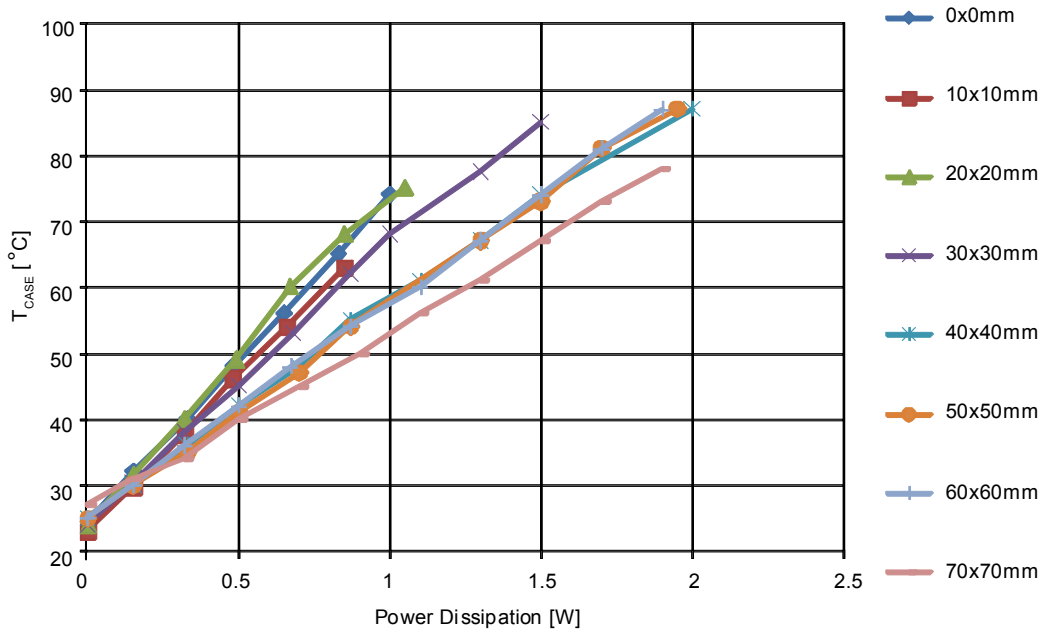

Figure 8.32 : Tcase vs Power QFN48 with Different Copper Area, Tamb = 25°C

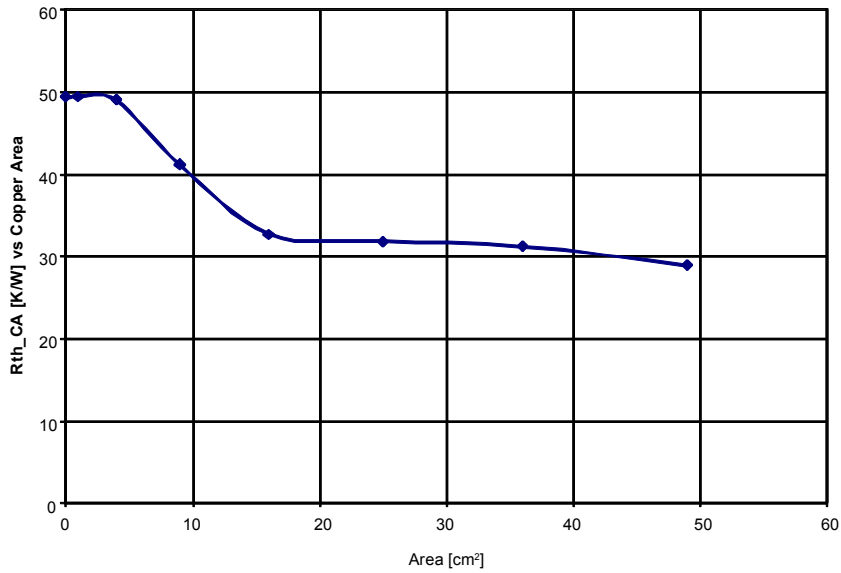

Figure 8.33 : Rth_CA [°C/W] vs Copper Area

16-Channel White LED Controller for LCD Backlight

9 Register Overview

Addr	Name	<D7>	<D6>	<D5>	<D4>	<D3>	<D2>	<D1>	<D0>	Default
Registers can only be written if Group1 is UNLOCKED. Default = LOCKED										
Registers can only be written if Group2 is UNLOCKED. Default = LOCKED										
0x00	Used for block writing									0x00
0x01	CUR_ON_1	curr_8	curr_7	curr_6	curr_5	curr_4	curr_3	curr_2	curr_1	0x00
0x02	CUR_ON_2	curr_16	curr_15	curr_14	curr_13	curr_12	curr_11	curr_10	curr_9	0x00
0x03	FAULT_1	auto-toff_uv	Short Bist_en	Shortcmp_en		retrial_open	autotoff_ot	open_en	autotoff_open	0x84
0x04	GPIO_CTRL	fault_n_config		mode3D_config		mode3D	DCDCEN_config		DCDCEN	0x00
0x05	FB_SEL_1	fb_sel[8]	fb_sel[7]	fb_sel[6]	fb_sel[5]	fb_sel[4]	fb_sel[3]	fb_sel[2]	fb_sel[1]	0x00
0x06	FB_SEL_2	fb_sel[16]	fb_sel[15]	fb_sel[14]	fb_sel[13]	fb_sel[12]	fb_sel[11]	fb_sel[10]	fb_sel[9]	0x00
0x07	CURR_CTRL	Sel_ac		Fb_ac_off	lb_comp	DACref_buffer	DACref	slew_rate		0x00
0x08	SHORTLED_1	shortled_8	shortled_7	shortled_6	shortled_5	shortled_4	shortled_3	shortled_2	shortled_1	0x00
0x09	SHORTLED_2	shortled_16	shortled_15	shortled_14	shortled_13	shortled_12	shortled_11	shortled_10	shortled_9	0x00
0x0A	OPENLED_1	open_8	open_7	open_6	open_5	open_4	open_3	open_2	open_1	0x00
0x0B	OPENLED_2	open_16	open_15	open_14	open_13	open_12	open_11	open_10	open_9	0x00
0x0C	VDAC_H	DAC[9]	DAC[8]	DAC[7]	DAC[6]	DAC[5]	DAC[4]	DAC[3]	DAC[2]	0x80
0x0D	VDAC_L							DAC[1]	DAC[0]	0x00
0x0E	FB_ON_1	fb_cur8	fb_cur7	fb_cur6	fb_cur5	fb_cur4	fb_cur3	fb_cur2	fb_cur1	0x00
0x0F	FB_ON_2	fb_cur16	fb_cur15	fb_cur14	fb_cur13	fb_cur12	fb_cur11	fb_cur10	fb_cur9	0x00
0x10	IDAC_FB1_COUNTER	idac_fb1_counter[7:0]								0x00
0x11	IDAC_FB2_COUNTER	idac_fb2_counter[7:0]								0x00
0x12	FBLOOP_CTRL	Vtrip		FB_cnt_man_fb2	FB_cnt_man_fb1	fbcounter_dn_time		fbcounter_up_time		0x05
0x13	PWM_CTRL	DPLL_per_sel	clock_src1	pwm_rev	vsync_det	vsync_edge	direct_pwm	update_mode	clock_src0	0x00
0x14	PWMperiodLSB	pwm_per7	pwm_per6	pwm_per5	pwm_per4	pwm_per3	pwm_per2	pwm_per1	pwm_per0	0x00
0x15	PWMperiodMSB	0	0	0	pwm_per12	pwm_per11	pwm_per10	pwm_per9	pwm_per8	0x00
0x16	PWM1delLSB	pwm1_del7	pwm1_del6	pwm1_del5	pwm1_del4	pwm1_del3	pwm1_del2	pwm1_del1	pwm1_del0	0x00
0x17	PWM1delMSB	0	0	0	0	pwm1_del11	pwm1_del10	pwm1_del9	pwm1_del8	0x00
0x18	PWM2delLSB	pwm2_del7	pwm2_del6	pwm2_del5	pwm2_del4	pwm2_del3	pwm2_del2	pwm2_del1	pwm2_del0	0x00
0x19	PWM2delMSB	0	0	0	0	pwm2_del11	pwm2_del10	pwm2_del9	pwm2_del8	0x00

16-Channel White LED Controller for LCD Backlight

Addr	Name	<D7>	<D6>	<D5>	<D4>	<D3>	<D2>	<D1>	<D0>	Default
0x1A	PWM3delLSB	pwm3 del7	pwm3 del6	pwm3 del5	pwm3 del4	pwm3 del3	pwm3 del2	pwm3 del1	pwm3 del0	0x00
0x1B	PWM3delMSB	0	0	0	0	pwm3 del11	pwm3 del10	pwm3 del9	pwm3 del8	0x00
0x1C	PWM4delLSB	pwm4 del7	pwm4 del6	pwm4 del5	pwm4 del4	pwm4 del3	pwm4 del2	pwm4 del1	pwm4 del0	0x00
0x1D	PWM4delMSB	0	0	0	0	pwm4 del11	pwm4 del10	pwm4 del9	pwm4 del8	0x00
0x1E	PWM5delLSB	pwm5 del7	pwm5 del6	pwm5 del5	pwm5 del4	pwm5 del3	pwm5 del2	pwm5 del1	pwm5 del0	0x00
0x1F	PWM5delMSB	0	0	0	0	pwm5 del11	pwm5 del10	pwm5 del9	pwm5 del8	0x00
0x20	PWM6delLSB	pwm6 del7	pwm6 del6	pwm6 del5	pwm6 del4	pwm6 del3	pwm6 del2	pwm6 del1	pwm6 del0	0x00
0x21	PWM6delMSB	0	0	0	0	pwm6 del11	pwm6 del10	pwm6 del9	pwm6 del8	0x00
0x22	PWM7delLSB	pwm7 del7	pwm7 del6	pwm7 del5	pwm7 del4	pwm7 del3	pwm7 del2	pwm7 del1	pwm7 del0	0x00
0x23	PWM7delMSB	0	0	0	0	pwm7 del11	pwm7 del10	pwm7 del9	pwm7 del8	0x00
0x24	PWM8delLSB	pwm8 del7	pwm8 del6	pwm8 del5	pwm8 del4	pwm8 del3	pwm8 del2	pwm8 del1	pwm8 del0	0x00
0x25	PWM8delMSB	0	0	0	0	pwm8 del11	pwm8 del10	pwm8 del9	pwm8 del8	0x00
0x26	PWM9delLSB	pwm9 del7	pwm9 del6	pwm9 del5	pwm9 del4	pwm9 del3	pwm9 del2	pwm9 del1	pwm9 del0	0x00
0x27	PWM9delMSB	0	0	0	0	pwm9 del11	pwm9 del10	pwm9 del9	pwm9 del8	0x00
0x28	PWM 10delLSB	pwm10 del7	pwm10 del6	pwm10 del5	pwm10 del4	pwm10 del3	pwm10 del2	pwm10 del1	pwm10 del0	0x00
0x29	PW10delMSB	0	0	0	0	pwm10 del11	pwm10 del10	pwm10 del9	pwm10 del8	0x00
0x2A	PWM 11delLSB	pwm11 del7	pwm11 del6	pwm11 del5	pwm11 del4	pwm11 del3	pwm11 del2	pwm11 del1	pwm11 del0	0x00
0x2B	PWM 11delMSB	0	0	0	0	pwm11 del11	pwm11 del10	pwm11 del9	pwm11 del8	0x00
0x2C	PWM 12delLSB	pwm12 del7	pwm12 del6	pwm12 del5	pwm12 del4	pwm12 del3	pwm12 del2	pwm12 del1	pwm12 del0	0x00
0x2D	PW12delMSB	0	0	0	0	pwm12 del11	pwm12 del10	pwm12 del9	pwm12 del8	0x00
0x2E	PWM 13delLSB	pwm13 del7	pwm13 del6	pwm13 del5	pwm13 del4	pwm13 del3	pwm13 del2	pwm13 del1	pwm13 del0	0x00
0x2F	PW13delMSB	0	0	0	0	pwm13 del11	pwm13 del10	pwm13 del9	pwm13 del8	0x00

16-Channel White LED Controller for LCD Backlight

Addr	Name	<D7>	<D6>	<D5>	<D4>	<D3>	<D2>	<D1>	<D0>	Default
0x30	PWM 14delLSB	pwm14 del7	pwm14 del6	pwm14 del5	pwm14 del4	pwm14 del3	pwm14 del2	pwm14 del1	pwm14 del0	0x00
0x31	PWM- 14delMSB	0	0	0	0	pwm14 del11	pwm14 del10	pwm14 del9	pwm14 del8	0x00
0x32	PWM 15delLSB	pwm15 del7	pwm15 del6	pwm15 del5	pwm15 del4	pwm15 del3	pwm15 del2	pwm15 del1	pwm15 del0	0x00
0x33	PWM- 15delMSB	0	0	0	0	pwm15 del11	pwm15 del10	pwm15 del9	pwm15 del8	0x00
0x34	PWM 16delLSB	pwm16 del7	pwm16 del6	pwm16 del5	pwm16 del4	pwm16 del3	pwm16 del2	pwm16 del1	pwm16 del0	0x00
0x35	PWM- 16delMSB	0	0	0	0	pwm16 del11	pwm16 del10	pwm16 del9	pwm16 del8	0x00
0x36	LOCKUN- LOCK	Magic Byte								0x00
0x37	PWM1htLSB	pwm1 ht7	pwm1 ht6	pwm1 ht5	pwm1 ht4	pwm1 ht3	pwm1 ht2	pwm1 ht1	pwm1 ht0	0x00
0x38	PWM1htMSB	0	0	0	0	pwm1 ht11	pwm1 ht10	pwm1 ht9	pwm1 ht8	0x00
0x39	PWM2htLSB	ht	pwm2 ht6	pwm2 ht5	pwm2 ht4	pwm2 ht3	pwm2 ht2	pwm2 ht1	pwm2 ht0	0x00
0x3A	PWM2htMSB	0	0	0	0	pwm2 ht11	pwm2 ht10	pwm2 ht9	pwm2 ht8	0x00
0x3B	PWM3htLSB	pwm3 ht7	pwm3 ht6	pwm3 ht5	pwm3 ht4	pwm3 ht3	pwm3 ht2	pwm3 ht1	pwm3 ht0	0x00
0x3C	PWM3htMSB	0	0	0	0	pwm3 ht11	pwm3 ht10	pwm3 ht9	pwm3 ht8	0x00
0x3D	PWM4htLSB	pwm4 ht7	pwm4 ht6	pwm4 ht5	pwm4 ht4	pwm4 ht3	pwm4 ht2	pwm4 ht1	pwm4 ht0	0x00
0x3E	PWM4htMSB	0	0	0	0	pwm4 ht11	pwm4 ht10	pwm4 ht9	pwm4 ht8	0x00
0x3F	PWM5htLSB	pwm5 ht7	pwm5 ht6	pwm5 ht5	pwm5 ht4	pwm5 ht3	pwm5 ht2	pwm5 ht1	pwm5 ht0	0x00
0x40	PWM5htMSB	0	0	0	0	pwm5 ht11	pwm5 ht10	pwm5 ht9	pwm5 ht8	0x00
0x41	PWM6htLSB	pwm6 ht7	pwm6 ht6	pwm6 ht5	pwm6 ht4	pwm6 ht3	pwm6 ht2	pwm6 ht1	pwm6 ht0	0x00
0x42	PWM6htMSB	0	0	0	0	pwm6 ht11	pwm6 ht10	pwm6 ht9	pwm6 ht8	0x00
0x43	PWM7htLSB	pwm7 ht7	pwm7 ht6	pwm7 ht5	pwm7 ht4	pwm7 ht3	pwm7 ht2	pwm7 ht1	pwm7 ht0	0x00
0x44	PWM7htMSB	0	0	0	0	pwm7 ht11	pwm7 ht10	pwm7 ht9	pwm7 ht8	0x00
0x45	PWM8htLSB	pwm8 ht7	pwm8 ht6	pwm8 ht5	pwm8 ht4	pwm8 ht3	pwm8 ht2	pwm8 ht1	pwm8 ht0	0x00
0x46	PWM8htMSB	0	0	0	0	pwm8 ht11	pwm8 ht10	pwm8 ht9	pwm8 ht8	0x00

16-Channel White LED Controller for LCD Backlight

Addr	Name	<D7>	<D6>	<D5>	<D4>	<D3>	<D2>	<D1>	<D0>	Default
0x47	PWM9htLSB	pwm9 ht7	pwm9 ht6	pwm9 ht5	pwm9 ht4	pwm9 ht3	pwm9 ht2	pwm9 ht1	pwm9 ht0	0x00
0x48	PWM9htMSB	0	0	0	0	pwm9 ht11	pwm9 ht10	pwm9 ht9	pwm9 ht8	0x00
0x49	PWM10htLSB	pwm10 ht7	pwm10 ht6	pwm10 ht5	pwm10 ht4	pwm10 ht3	pwm10 ht2	pwm10 ht1	pwm10 ht0	0x00
0x4A	PWM10htMSB	0	0	0	0	pwm10 ht11	pwm10 ht10	pwm10 ht9	pwm10 ht8	0x00
0x4B	PWM11htLSB	pwm11 ht7	pwm11 ht6	pwm11 ht5	pwm11 ht4	pwm11 ht3	pwm11 ht2	pwm11 ht1	pwm11 ht0	0x00
0x4C	PWM11htMSB	0	0	0	0	pwm11 ht11	pwm11 ht10	pwm11 ht9	pwm11 ht8	0x00
0x4D	PWM12htLSB	pwm12 ht7	pwm12 ht6	pwm12 ht5	pwm12 ht4	pwm12 ht3	pwm12 ht2	pwm12 ht1	pwm12 ht0	0x00
0x4E	PWM12htMSB	0	0	0	0	pwm12 ht11	pwm12 ht10	pwm12 ht9	pwm12 ht8	0x00
0x4F	PWM13htLSB	pwm13 ht7	pwm13 ht6	pwm13 ht5	pwm13 ht4	pwm13 ht3	pwm13 ht2	pwm13 ht1	pwm13 ht0	0x00
0x50	PWM13htMSB	0	0	0	0	pwm13 ht11	pwm13 ht10	pwm13 ht9	pwm13 ht8	0x00
0x51	PWM14htLSB	pwm14 ht7	pwm14 ht6	pwm14 ht5	pwm14 ht4	pwm14 ht3	pwm14 ht2	pwm14 ht1	pwm14 ht0	0x00
0x52	PWM14htMSB	0	0	0	0	pwm14 ht11	pwm14 ht10	pwm14 ht9	pwm14 ht8	0x00
0x53	PWM15htLSB	pwm15 ht7	pwm15 ht6	pwm15 ht5	pwm15 ht4	pwm15 ht3	pwm15 ht2	pwm15 ht1	pwm15 ht0	0x00
0x54	PWM15htMSB	0	0	0	0	pwm15 ht11	pwm15 ht10	pwm15 ht9	pwm15 ht8	0x00
0x55	PWM16htLSB	pwm16 ht7	pwm16 ht6	pwm16 ht5	pwm16 ht4	pwm16 ht3	pwm16 ht2	pwm16 ht1	pwm16 ht0	0x00
0x56	PWM16htMSB	0	0	0	0	pwm16 ht11	pwm16 ht10	pwm16 ht9	pwm16 ht8	0x00
0x57	ASICIDLSB	asic_id0				rev. nr.				0x00
0x58	ASICIDMSB	asic_id2				asic_id1				0x00
0x59	Not used									0x00
0x60	STATUS	no_sync	stat ot	stat open	short_bist	vcnt underflow	short2	short1	power_good	0x00
0x61	PLLmultiMSB	PLL Multi15	PLL Multi14	PLL Multi13	PLL Multi12	PLL Multi11	PLL Multi10	PLL Multi9	PLL Multi8	0x00
0x62	PLLmultiLSB	PLL Multi7	PLL Multi6	PLL Multi5	PLL Multi4	PLL Multi3	PLL Multi2	PLL Multi1	PLL Multi0	0x00
0x63	SHORT_BIST_CTRL1	0	0	0	bist_retrial	bist_stepstime	autooff_BIST	bist_wait		0x02
0x64	SHORT_BIST_MAXSTEP	bist_maxstep7	bist_maxstep6	bist_maxstep5	bist_maxstep4	bist_maxstep3	bist_maxstep2	bist_maxstep1	bist_maxstep0	0xFF
0x65	SHORT_BIST_CTRL2	0	0	comp_retrial	autotoff_comp	comp_level				0x0A

16-Channel White LED Controller for LCD Backlight

Addr	Name	<D7>	<D6>	<D5>	<D4>	<D3>	<D2>	<D1>	<D0>	Default
0x6C	CompReg_1	Comp Reg8	Comp Reg7	Comp Reg6	Comp Reg5	Comp Reg4	Comp Reg3	Comp Reg2	Comp Reg1	0x00
0x6D	CompReg_2	Comp Reg16	Comp Reg15	Comp Reg14	Comp Reg13	Comp Reg12	Comp Reg11	Comp Reg10	Comp Reg9	0x00

Note 1. Addresses from 0x66 to 0x6b and above 0x6d are for factory test only. DO NOT WRITE!

Table 6: Shows an overview of the Register Map

16-Channel White LED Controller for LCD Backlight

10 Physical Dimensions

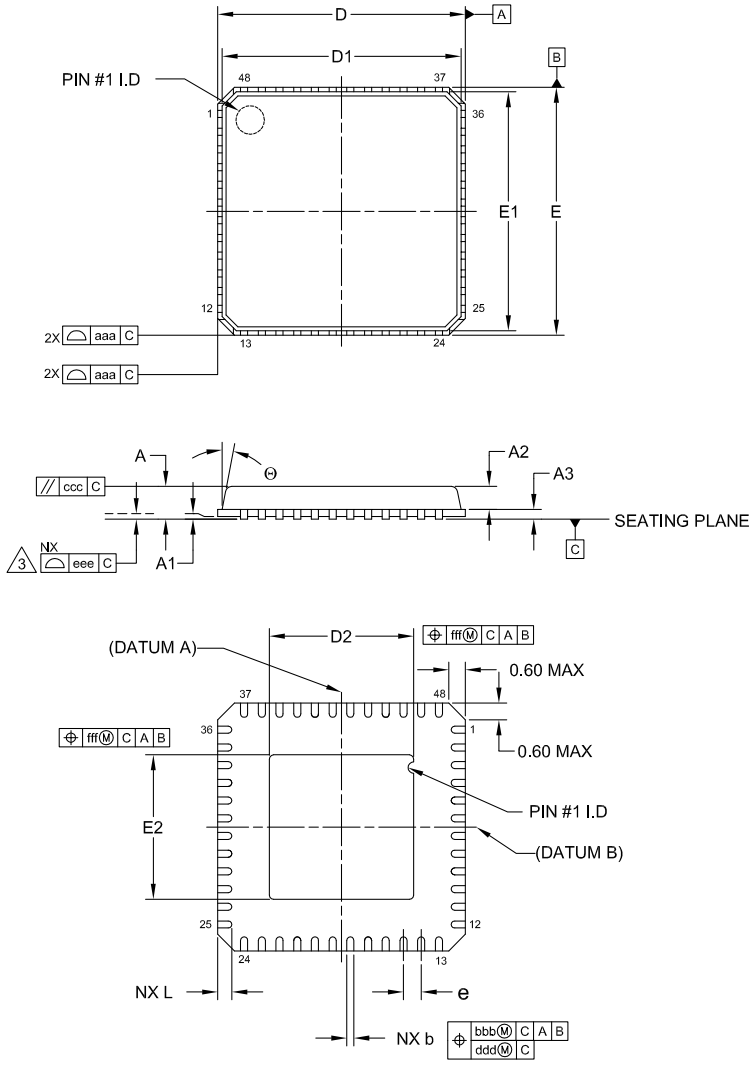

REF.	MIN	NOM	MAX
A	0.80	0.90	1.00
A1	0	0.02	0.05
A2	-	0.65	1.00
A3	-	0.20 REF	-
L	0.35	0.40	0.45
theta	0°	-	14°
b	0.18	0.25	0.30
D	-	7.00 BSC	-
E	-	7.00 BSC	-
e	-	0.50 BSC	-
D2	4.00	4.10	4.20
E2	4.00	4.10	4.20
D1	-	6.75 BSC	-
E1	-	6.75 BSC	-
aaa	-	0.15	-
bbb	-	0.10	-
ccc	-	0.10	-
ddd	-	0.05	-
eee	-	0.08	-
fff	-	0.10	-
N	-	48	-

NOTE:

1. DIMENSIONING AND TOLERANCING CONFORM TO ASME Y14.5M-1994.
2. ALL DIMENSIONS ARE IN MILLIMETERS (ANGLES IN DEGREES)
3. COPLANARITY APPLIES TO THE EXPOSED HEAT SLUG AS WELL AS THE TERMINAL.
4. RADIUS ON TERMINAL IS OPTIONAL.
5. N IS THE TOTAL NUMBER OF TERMINALS.

Figure 10.1 : QFN-48 package outline drawing

16-Channel White LED Controller for LCD Backlight

11 Ordering Information

Part Number	Ordering Code	Options	Package	Description
AS3820A	AS3820A-ZQFT	16 Channel White LED Controller for LCD Backlight	48-Pin QFN	Tape & Reel ¹
AS3820E	AS3820E-ZQFT	16 Channel White LED Controller for LCD Backlight Direct PWM Mode Activated	48-Pin QFN	Tape & Reel ¹

Note 1. Tape & Reel packing quantity is 4,000/reel. Minimum packing quantity is 4,000.

Note 2. Additional features and options may be available; contact Dialog Semiconductor.

16-Channel White LED Controller for LCD Backlight

Disclaimer

Information in this document is believed to be accurate and reliable. However, Dialog Semiconductor does not give any representations or warranties, expressed or implied, as to the accuracy or completeness of such information. Dialog Semiconductor furthermore takes no responsibility whatsoever for the content in this document if provided by any information source outside of Dialog Semiconductor.

Dialog Semiconductor reserves the right to change without notice the information published in this document, including without limitation the specification and the design of the related semiconductor products, software and applications.

Applications, software, and semiconductor products described in this document are for illustrative purposes only. Dialog Semiconductor makes no representation or warranty that such applications, software and semiconductor products will be suitable for the specified use without further testing or modification. Unless otherwise agreed in writing, such testing or modification is the sole responsibility of the customer and Dialog Semiconductor excludes all liability in this respect.

Customer notes that nothing in this document may be construed as a license for customer to use the Dialog Semiconductor products, software and applications referred to in this document. Such license must be separately sought by customer with Dialog Semiconductor.

All use of Dialog Semiconductor products, software and applications referred to in this document are subject to [Dialog Semiconductor's Standard Terms and Conditions of Sale](#), available on the company website (www.dialog-semiconductor.com) unless otherwise stated.

Dialog and the Dialog logo are trademarks of Dialog Semiconductor plc or its subsidiaries. All other product or service names are the property of their respective owners.

© 2018 Dialog Semiconductor. All rights reserved.

RoHS Compliance

Dialog Semiconductor's suppliers certify that its products are in compliance with the requirements of Directive 2011/65/EU of the European Parliament on the restriction of the use of certain hazardous substances in electrical and electronic equipment. RoHS certificates from our suppliers are available on request.

Contacting Dialog Semiconductor

United Kingdom (Headquarters)
Dialog Semiconductor (UK) LTD
Phone: +44 1793 757700

Germany
Dialog Semiconductor GmbH
Phone: +49 7021 805-0

The Netherlands
Dialog Semiconductor B.V.
Phone: +31 73 640 8822

Email
info_pcbg@diasemi.com

North America
Dialog Semiconductor Inc.
Phone: +1 408 845 8500

Japan
Dialog Semiconductor K. K.
Phone: +81 3 5769 5100

Taiwan
Dialog Semiconductor Taiwan
Phone: +886 281 786 222

Web site:
www.dialog-semiconductor.com

Hong Kong
Dialog Semiconductor Hong Kong
Phone: +852 2607 4271

Korea
Dialog Semiconductor Korea
Phone: +82 2 3469 8200

China (Shenzhen)
Dialog Semiconductor China
Phone: +86 755 2981 3669

China (Shanghai)
Dialog Semiconductor China
Phone: +86 21 5424 9058