

Multi-Channel Narrowband FSK Transmitter

AS3977

PRODUCT BRIEF

1. General Description

The AS3977 is a low-power fully integrated ETSI, FCC and ARIB compliant FSK transmitter capable of operating at any ISM frequency in the range of 300 to 928 MHz. It is based on a sigma-delta controlled fractional-N synthesiser phase locked loop with fully integrated voltage controlled oscillator. The power amplifier output is programmable and can deliver output power ranging from -20dBm up to +10dBm. An on-chip low drop-out regulator is available in case an accurate output power independent of voltage supply variation is required.

The output signal can be shaped using a programmable Gaussian filter to minimise the occupied bandwidth and adjacent channel power. The maximum data rate can be up to 100 kb/s – depending on the required filtering.

The FSK frequency deviation is programmable up to a maximum of 64kHz.

The crystal oscillator can handle a wide range of frequencies. For narrow-band applications a temperature sensor with digital read-out is included that allows compensation of the crystal frequency drift due to temperature variation.

The AS3977 is connected to an external microcontroller via a bi-directional digital interface. The device operates at very low current consumption with a power supply range from 2.0V to 3.6V and can be powered down when not in use.

The device is fabricated in austriamicrosystems advanced 0.35um SiGe-BiCMOS technology.

2. Key Features

- Compliant to ETSI EN 300-220, FCC CFR 47 part 15 and ARIB STD-T67
- Multi-channel with narrow bandwidth
- 300 – 928 MHz operating frequency range (ISM)
- Filtered FSK
- Data rate up to 100 kb/s
- FSK deviation programmable up to 64kHz
- Extremely low power consumption

3. Main Characteristics

- 2.0 – 3.6V power supply
- Power down current consumption 100 nA (3V, 25°C)
- Output power up to +10dBm
- Occupied bandwidth 8.5 kHz (4.8 kb/s, FFSK, ARIB)
- Operating temperature range -40°C to +85°C

4. Additional Features

- Sigma-Delta controlled fractional-N synthesiser
- Resolution of synthesiser <100Hz
- Fully integrated PLL
- Fully integrated voltage controlled oscillator
- 4kV ESD protection (1.5kV for analogue pins)
- Automatic antenna tuning
- 12 – 20 MHz crystal oscillator
- On-chip temperature sensor with digital readout for AFC purposes
- Integrated Manchester coder
- Digital lock detector
- Low drop-out regulator
- Bi-directional serial interface

5. Applications

- Remote keyless entry systems
- Short range radio data transmission
- Domestic and consumer remote control units
- Cordless alarm systems
- Remote metering
- Low power telemetry

Block Diagram AS3977

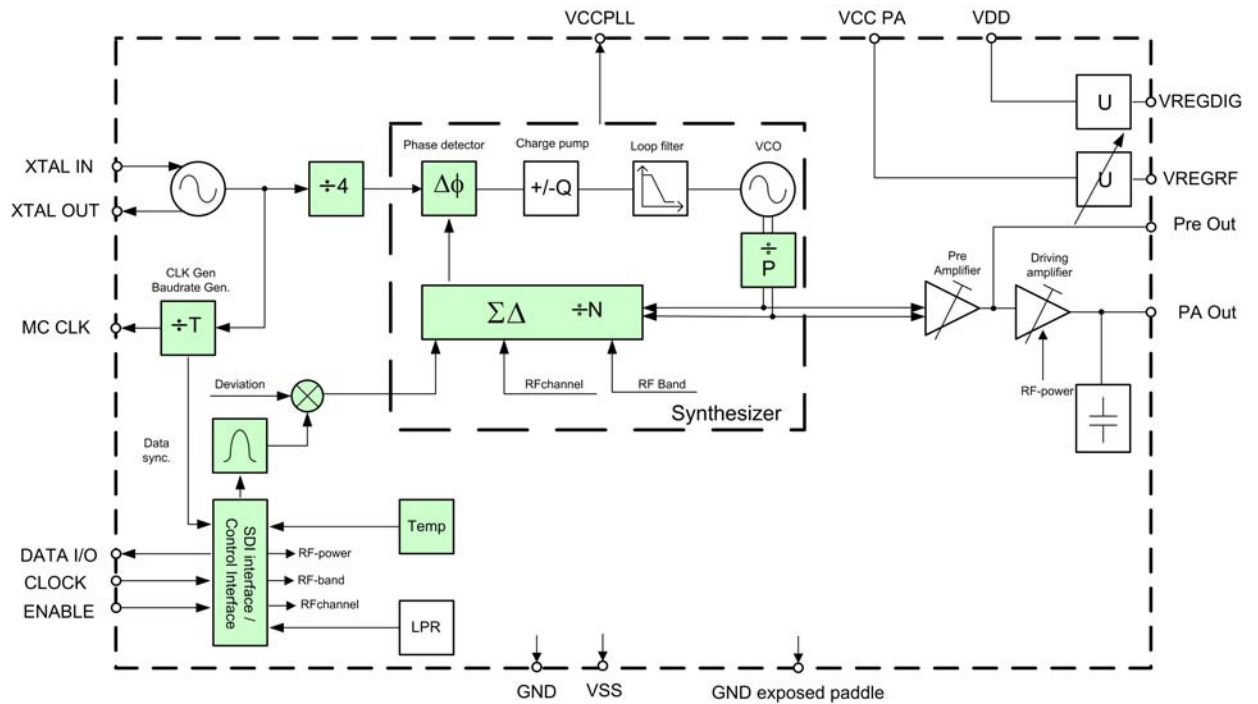

Package, Pin-out and Marking

16 pin QFN4x4 16LD

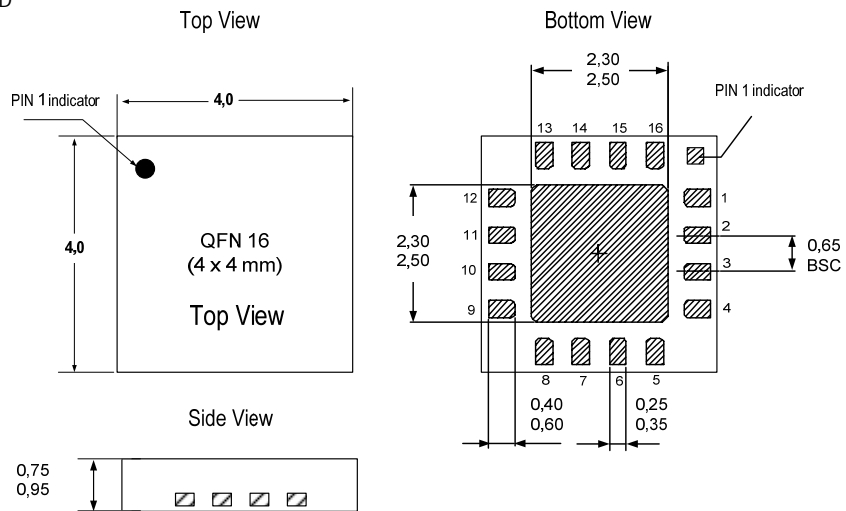

1	PREOUT	16	VREGRF
2	PAOUT	15	VCCPA
3	nc	14	nc
4	VCCPLL	13	VSS
5	ENABLE	12	MCCLK
6	CLK	11	DATAIO
7	XTALIN	10	VDD
8	XTALOUT	9	VREGDIG
ep	GND		

AYWWXZ = Date Code and Plant ID

