



# DRAM

# 4 MEG x 4 DRAM

## 3.3V, EDO PAGE MODE

### AVAILABLE IN MILITARY SPECIFICATIONS

- MIL-STD-883
- SMD Planned

### FEATURES

- Industry-standard x4 pinout, timing, functions and packages
- High-performance CMOS silicon-gate process
- Single +3.3V  $\pm 0.3V$  power supply
- Low power, 1mW standby; 150mW active, typical
- All inputs, outputs and clocks are TTL-compatible
- Refresh modes:  $\overline{RAS}$  ONLY,  $\overline{CAS}$ -BEFORE- $\overline{RAS}$  (CBR) HIDDEN
- 2,048-cycle (11 row-, 11 column-addresses)
- Extended Data-Out (EDO) PAGE access cycle
- 5V-tolerant I/Os (5.5V maximum  $V_{IH}$  level)

### OPTIONS

- Timing
  - 60ns access (Contact Factory)
  - 70ns access
  - 80ns access

### • Packages

Ceramic SOJ  
Ceramic LCC  
Ceramic Gull Wing

### MARKING

ECJ No. 505  
EC No. 212  
ECG No. 603

### KEY TIMING PARAMETERS

SPEED	$t_{RC}$	$t_{RAC}$	$t_{PC}$	$t_{AA}$	$t_{CAC}$	$t_{CAS}$
-6	110ns	60ns	30ns	30ns	15ns	12ns
-7	130ns	70ns	35ns	35ns	18ns	15ns
-8	150ns	80ns	40ns	40ns	20ns	20ns

### GENERAL DESCRIPTION

The AS4LC4M4 is a randomly accessed solid-state memory containing 16,777,216 bits organized in a x4 configuration. The AS4LC4M4  $\overline{RAS}$  is used to latch the first 11 bits and  $\overline{CAS}$  the latter 11 bits. READ and WRITE cycles are selected with the  $\overline{WE}$  input. A logic HIGH on  $\overline{WE}$  dictates READ mode while a logic LOW on  $\overline{WE}$  dictates WRITE mode. During a WRITE cycle, data-in (D) is latched by the falling edge of  $\overline{WE}$  or  $\overline{CAS}$ , whichever occurs last. If  $\overline{WE}$  goes LOW prior to  $\overline{CAS}$  going LOW, the output pins remain open (High-Z) until the next  $\overline{CAS}$  cycle, regardless of  $\overline{OE}$ .

### PIN ASSIGNMENT (Top View)

#### 24/28-Pin

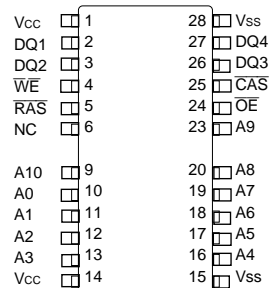

A logic HIGH on  $\overline{WE}$  dictates READ mode while a logic LOW on  $\overline{WE}$  dictates WRITE mode. During a WRITE cycle, data-in (D) is latched by the falling edge of  $\overline{WE}$  or  $\overline{CAS}$ , whichever occurs last. An EARLY WRITE occurs when  $\overline{WE}$  is taken LOW prior to  $\overline{CAS}$  falling. A LATE WRITE or READ-MODIFY-WRITE occurs when  $\overline{WE}$  falls after  $\overline{CAS}$  was taken LOW. During EARLY WRITE cycles, the data-outputs (Q) will remain High-Z regardless of the state of  $\overline{OE}$ . During LATE WRITE or READ-MODIFY-WRITE cycles,  $\overline{OE}$  must be taken HIGH to disable the data-outputs prior to applying input data. If a LATE WRITE or READ-MODIFY-WRITE is attempted while keeping  $\overline{OE}$  LOW, no write will occur, and the data-outputs will drive read data from the accessed location.

The four data inputs and the four data outputs are routed through four pins using common I/O, and pin direction is controlled by  $\overline{WE}$  and  $\overline{OE}$ .

### FAST PAGE MODE

FAST PAGE operations allow faster data operations (READ, WRITE or READ-MODIFY-WRITE) within a row-address-defined page boundary. The FAST PAGE cycle is always initiated with a row-address strobed-in by  $\overline{RAS}$  followed by a column-address strobed-in by  $\overline{CAS}$ .  $\overline{CAS}$  may be toggled-in by holding  $\overline{RAS}$  LOW and strobing-in different column-addresses, thus executing faster memory cycles. Returning  $\overline{RAS}$  HIGH terminates the FAST PAGE MODE of operation.



### EDO PAGE MODE

The AS4LC4M4E8 provides EDO PAGE MODE which is an accelerated FAST PAGE MODE cycle. The primary advantage of EDO is the availability of data-out even after  $\overline{\text{CAS}}$  returns HIGH. EDO allows  $\overline{\text{CAS}}$  precharge time ( $t_{CP}$ ) to occur without the output data going invalid. This elimination of  $\overline{\text{CAS}}$  output control allows pipeline READS.

FAST-PAGE-MODE DRAMs have traditionally turned the output buffers off (High-Z) with the rising edge of  $\overline{\text{CAS}}$ . EDO-PAGE-MODE DRAMs operate similarly to FAST-PAGE-MODE DRAMs, except data will remain valid or become valid after  $\overline{\text{CAS}}$  goes HIGH during READS, provided  $\overline{\text{RAS}}$  and  $\overline{\text{OE}}$  are held LOW. If  $\overline{\text{OE}}$  is pulsed while

$\overline{\text{RAS}}$  and  $\overline{\text{CAS}}$  are LOW, data will toggle from valid data to High-Z and back to the same valid data. If  $\overline{\text{OE}}$  is toggled or pulsed after  $\overline{\text{CAS}}$  goes HIGH while  $\overline{\text{RAS}}$  remains LOW, data will transition to and remain High-Z (refer to Figure 1).  $\overline{\text{WE}}$  can also perform the function of disabling the output devices under certain conditions, as shown in Figure 2.

During an application, if the DQ outputs are wire OR'd,  $\overline{\text{OE}}$  must be used to disable idle banks of DRAMs. Alternatively, pulsing  $\overline{\text{WE}}$  to the idle banks during  $\overline{\text{CAS}}$  high time will also High-Z the outputs. Independent of  $\overline{\text{OE}}$  control, the outputs will disable after  $t_{OFF}$ , which is referenced from the rising edge of  $\overline{\text{RAS}}$  or  $\overline{\text{CAS}}$ , whichever occurs last.

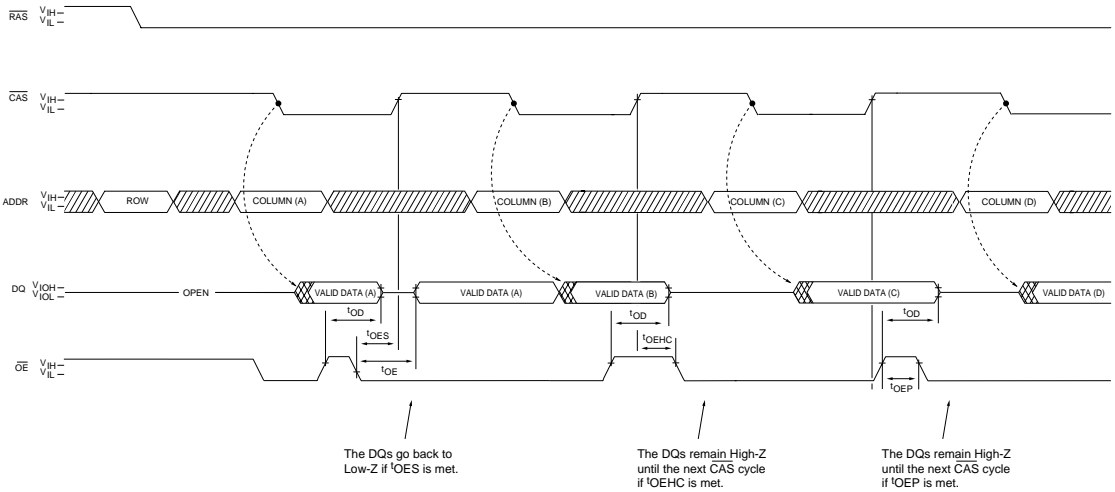
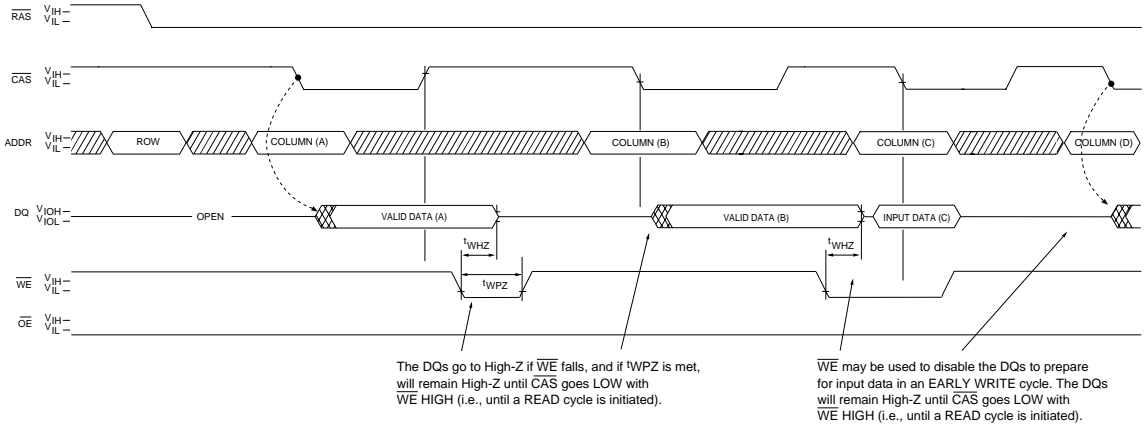

**Figure 1**  
**OUTPUT ENABLE AND DISABLE**



### REFRESH

Preserve correct memory cell data by maintaining power and executing a  $\overline{\text{RAS}}$  cycle (READ, WRITE) or  $\overline{\text{RAS}}$  refresh cycle ( $\overline{\text{RAS}}$  ONLY, CBR, or HIDDEN) so that all 2,048 combinations of  $\overline{\text{RAS}}$  addresses are executed at least every 32ms, regardless of sequence. The CBR REFRESH cycle will invoke the refresh counter for automatic  $\overline{\text{RAS}}$  addressing.



DON'T CARE  
 UNDEFINED

Figure 2  
 **$\overline{\text{WE}}$  CONTROL OF DQs**



FUNCTIONAL BLOCK DIAGRAM

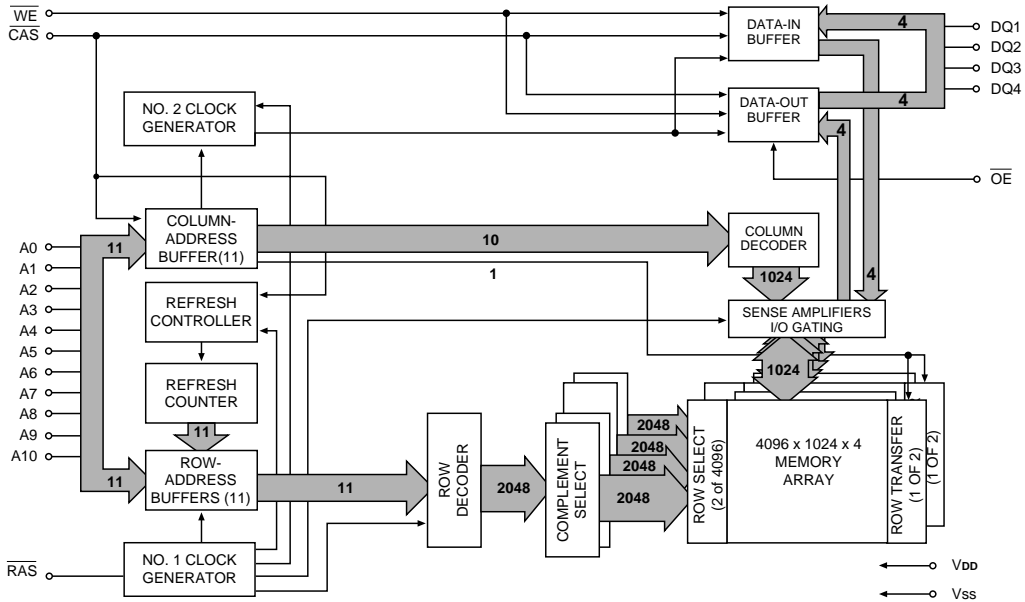

TRUTH TABLE

FUNCTION	RAS	CAS	WE	OE	ADDRESSES		DATA-IN/OUT	
					t <sub>R</sub>	t <sub>C</sub>	DQ1-DQ4	
Standby	H	H→X	X	X	X	X	High-Z	
READ	L	L	H	L	ROW	COL	Data-Out	
EARLY WRITE	L	L	L	X	ROW	COL	Data-In	
READ WRITE	L	L	H→L	L→H	ROW	COL	Data-Out, Data-In	
EDO-PAGE-MODE READ	1st Cycle	L	H→L	H	L	ROW	COL	Data-Out
	2nd Cycle	L	H→L	H	L	n/a	COL	Data-Out
EDO-PAGE-MODE EARLY-WRITE	1st Cycle	L	H→L	L	X	ROW	COL	Data-In
	2nd Cycle	L	H→L	L	X	n/a	COL	Data-In
	Any Cycle	L	L→H	H	L	n/a	n/a	Data-Out
EDO-PAGE-MODE READ-WRITE	1st Cycle	L	H→L	H→L	L→H	ROW	COL	Data-Out, Data-In
	2nd Cycle	L	H→L	H→L	L→H	n/a	COL	Data-Out, Data-In
HIDDEN READ	L→H→L	L	H	L	ROW	COL	Data-Out	
REFRESH WRITE	L→H→L	L	L	X	ROW	COL	Data-In	
RAS-ONLY REFRESH	L	H	X	X	ROW	n/a	High-Z	
CBR REFRESH	H→L	L	H	X	X	X	High-Z	



ABSOLUTE MAXIMUM RATINGS\*

Voltage on Vcc pin Relative to Vss ..... -1V to +4.6V
Voltage on NC, Inputs or I/O pins
Relative to Vss ..... -1V to +5.5V
Operating Temperature, TA (ambient) .. TA(MIN) = -55°C
..... TC (MAX) = 125°C
Storage Temperature ..... -55°C to +150°C
Power Dissipation ..... 1W
Short Circuit Output Current ..... 50mA

\*Stresses greater than those listed under "Absolute Maximum Ratings" may cause permanent damage to the device. This is a stress rating only and functional operation of the device at these or any other conditions above those indicated in the operational sections of this specification is not implied. Exposure to absolute maximum rating conditions for extended periods may affect reliability.

ELECTRICAL CHARACTERISTICS AND RECOMMENDED DC OPERATING CONDITIONS

(Notes: 1, 6, 7) (Vcc = +3.3V ±0.3V)

Table with 6 columns: PARAMETER/CONDITION, SYMBOL, MIN, MAX, UNITS, NOTES. Rows include Supply Voltage, Input High/Low Voltage, INPUT LEAKAGE CURRENT, OUTPUT LEAKAGE CURRENT, and OUTPUT LEVELS.

Table with 7 columns: PARAMETER/CONDITION, SYM, MAX (-6, -7, -8), UNITS, NOTES. Rows include STANDBY CURRENT (TTL, CMOS), OPERATING CURRENT (Random READ/WRITE, EDO PAGE MODE), and REFRESH CURRENT (RAS ONLY, CBR).



## CAPACITANCE

PARAMETER	SYMBOL	MAX	UNITS	NOTES
Input Capacitance: Address pins	C <sub>I1</sub>	7	pF	2
Input Capacitance: RAS, CAS, WE, OE	C <sub>I2</sub>	7	pF	2
Input/Output Capacitance: DQ	C <sub>IO</sub>	8	pF	2

## ELECTRICAL CHARACTERISTICS AND RECOMMENDED AC OPERATING CONDITIONS

(Notes: 6, 7, 8, 9, 10, 11, 12, 13) (V<sub>CC</sub> = +3.3V ±0.3V)

AC CHARACTERISTICS PARAMETER	SYM	-6		-7		-8		UNITS	NOTES
		MIN	MAX	MIN	MAX	MIN	MAX		
Access time from column-address	<sup>t</sup> AA		30		35		40	ns	
Column-address set-up to CAS precharge during write	<sup>t</sup> ACH	15		15		20		ns	
Column-address hold time (referenced to RAS)	<sup>t</sup> AR	45		55		60		ns	
Column-address setup time	<sup>t</sup> ASC	0		0		0		ns	
Row-address setup time	<sup>t</sup> ASR	0		0		0		ns	
Column-address to WE delay time	<sup>t</sup> AWD	55		65		65		ns	20
Access time from CAS	<sup>t</sup> CAC		15		20		20	ns	14
Column-address hold time	<sup>t</sup> CAH	10		15		15		ns	
CAS pulse width	<sup>t</sup> CAS	12	10,000	15	10,000	20	10,000	ns	
CAS hold time (CBR REFRESH)	<sup>t</sup> CHR	10		15		15		ns	5
CAS to output in Low-Z	<sup>t</sup> CLZ	0		0		0		ns	
Data output hold after next CAS LOW	<sup>t</sup> COH	5		5		5		ns	
CAS precharge time	<sup>t</sup> CP	10		10		10		ns	15
Access time from CAS precharge	<sup>t</sup> CPA		35		40		40	ns	
CAS to RAS precharge time	<sup>t</sup> CRP	5		5		5		ns	
CAS hold time	<sup>t</sup> CSH	50		55		60		ns	
CAS setup time (CBR REFRESH)	<sup>t</sup> CSR	5		5		10		ns	5
CAS to WE delay time	<sup>t</sup> CWD	35		40		45		ns	20
Write command to CAS lead time	<sup>t</sup> CWL	15		15		20		ns	
Data-in hold time	<sup>t</sup> DH	10		12		15		ns	21
Data-in hold time (referenced to RAS)	<sup>t</sup> DHR	40		56		55		ns	
Data-in setup time	<sup>t</sup> DS	0		0		0		ns	21
Output disable	<sup>t</sup> OD	0	15	0	15		20	ns	
Output Enable	<sup>t</sup> OE		15		20		20	ns	22
OE hold time from WE during READ-MODIFY-WRITE cycle	<sup>t</sup> OEH	10		12		15		ns	
OE HIGH hold from CAS HIGH	<sup>t</sup> OEHC	10		10		10		ns	
OE HIGH pulse width	<sup>t</sup> OEP	10		10		10		ns	
OE LOW to CAS HIGH setup time	<sup>t</sup> OES	5		5		5		ns	



**ELECTRICAL CHARACTERISTICS AND RECOMMENDED AC OPERATING CONDITIONS**

(Notes: 6, 7, 8, 9, 10, 11, 12, 13) ( $V_{CC} = +3.3V \pm 0.3V$ )

AC CHARACTERISTICS		-6		-7		-8			
PARAMETER	SYM	MIN	MAX	MIN	MAX	MIN	MAX	UNITS	NOTES
Output buffer turn-off delay	$t_{OFF}$	0	15	0	15	0	20	ns	
OE setup prior to RAS during HIDDEN REFRESH cycle	$t_{ORD}$	0		0		0		ns	19
EDO-PAGE-MODE READ or WRITE cycle time	$t_{PC}$	30		35		40		ns	
EDO-PAGE-MODE READ-WRITE cycle time	$t_{PRWC}$	75		85		90		ns	
Access time from RAS	$t_{RAC}$		60		70		80	ns	13
RAS to column-address delay time	$t_{RAD}$	15	30	15	35	15	40	ns	17
Row-address hold time	$t_{RAH}$	10		10		10		ns	
Column-address to RAS lead time	$t_{RAL}$	30		35		40		ns	
RAS pulse width	$t_{RAS}$	60	10,000	70	10,000	80	10,000	ns	
RAS pulse width (EDO PAGE MODE)	$t_{RASP}$	60	100,000	70	100,000	80	100,000	ns	
Random READ or WRITE cycle time	$t_{RC}$	110		130		150		ns	
RAS to CAS delay time	$t_{RCD}$	16	45	16	50	20	60	ns	16
Read command hold time (referenced to CAS)	$t_{RCH}$	0		0		0		ns	18
Read command setup time	$t_{RCS}$	0		0		0		ns	
Refresh period (2,048 cycles)	$t_{REF}$		32		32		32	ms	
RAS precharge time	$t_{RP}$	40		50		60		ns	
RAS to CAS precharge time	$t_{RPC}$	5		5		5		ns	
Read command hold time (referenced to RAS)	$t_{RRH}$	0		0		0		ns	18
RAS hold time	$t_{RSH}$	13		15		15		ns	
READ WRITE cycle time	$t_{RWC}$	150		180		200		ns	
RAS to WE delay time	$t_{RWD}$	80		90		105		ns	20
Write command to RAS lead time	$t_{RWL}$	15		15		20		ns	
Transition time (rise or fall)	$t_T$	2	30	2	30	2	30	ns	
Write command hold time	$t_{WCH}$	10		12		15		ns	
Write command hold time (referenced to RAS)	$t_{WCR}$	40		56		60		ns	
WE command setup time	$t_{WCS}$	0		0		0		ns	20
Output disable delay from WE	$t_{WHZ}$	0	14	0	16	0	20	ns	
Write command pulse width	$t_{WP}$	10		12		15		ns	
WE pulse to disable at CAS HIGH	$t_{WPZ}$	10		12		15		ns	
WE hold time (CBR REFRESH)	$t_{WRH}$	10		10		10		ns	24
WE setup time (CBR REFRESH)	$t_{WRP}$	10		10		10		ns	24



## NOTES

1. All voltages referenced to  $V_{SS}$ .
2. This parameter is sampled.  $V_{CC} = +3.3V$ ;  $f = 1$  MHz.
3.  $I_{CC}$  is dependent on cycle rates.
4.  $I_{CC}$  is dependent on output loading and cycle rates. Specified values are obtained with minimum cycle time and the outputs open.
5. Enables on-chip refresh and address counters.
6. The minimum specifications are used only to indicate cycle time at which proper operation over the full temperature range is assured.
7. An initial pause of  $100\mu s$  is required after power-up followed by eight  $\overline{RAS}$  refresh cycles ( $\overline{RAS}$  ONLY or CBR with  $\overline{WE}$  HIGH) before proper device operation is assured. The eight  $\overline{RAS}$  cycle wake-ups should be repeated any time the  $\overline{REF}$  refresh requirement is exceeded.
8. AC characteristics assume  $t_T = 2.5ns$ .
9.  $V_{IH}$  (MIN) and  $V_{IL}$  (MAX) are reference levels for measuring timing of input signals. Transition times are measured between  $V_{IH}$  and  $V_{IL}$  (or between  $V_{IL}$  and  $V_{IH}$ ).
10. In addition to meeting the transition rate specification, all input signals must transit between  $V_{IH}$  and  $V_{IL}$  (or between  $V_{IL}$  and  $V_{IH}$ ) in a monotonic manner.
11. Column address changed once each cycle.
12. Measured with a load equivalent to two TTL gates,  $100pF$  and  $V_{OL} = 0.8V$  and  $V_{OH} = 2.0V$ .
13. Assumes that  $t_{RCD} < t_{RCD} (MAX)$ . If  $t_{RCD}$  is greater than the maximum recommended value shown in this table,  $t_{RAC}$  will increase by the amount that  $t_{RCD}$  exceeds the value shown.
14. Assumes that  $t_{RCD} \geq t_{RCD} (MAX)$ .
15. If  $\overline{CAS}$  is LOW at the falling edge of  $\overline{RAS}$ ,  $Q$  will be maintained from the previous cycle. To initiate a new cycle and clear the data-out buffer,  $\overline{CAS}$  must be pulsed HIGH for  $t_{CP}$ .
16. Operation within the  $t_{RCD} (MAX)$  limit ensures that  $t_{RAC} (MAX)$  can be met.  $t_{RCD} (MAX)$  is specified as a reference point only; if  $t_{RCD}$  is greater than the specified  $t_{RCD} (MAX)$  limit, then access time is controlled exclusively by  $t_{CAC}$ , provided  $t_{RAD}$  is not exceeded.
17. Operation within the  $t_{RAD} (MAX)$  limit ensures that  $t_{RAC} (MIN)$  and  $t_{CAC} (MIN)$  can be met.  $t_{RAD} (MAX)$  is specified as a reference point only; if  $t_{RAD}$  is greater than the specified  $t_{RAD} (MAX)$  limit, then access time is controlled exclusively by  $t_{AA}$ , provided  $t_{RCD}$  is not exceeded.
18. Either  $t_{RCH}$  or  $t_{RRH}$  must be satisfied for a READ cycle.
19.  $t_{OFF} (MAX)$  defines the time at which the output achieves the open circuit condition, and is not referenced to  $V_{OH}$  or  $V_{OL}$ . It is referenced from the rising edge of  $\overline{RAS}$  or  $\overline{CAS}$ , whichever occurs last.
20.  $t_{WCS}$ ,  $t_{RWD}$ ,  $t_{AWD}$  and  $t_{CWD}$  are not restrictive operating parameters.  $t_{WCS}$  applies to EARLY WRITE cycles.  $t_{RWD}$ ,  $t_{AWD}$  and  $t_{CWD}$  apply to READ-MODIFY-WRITE cycles. If  $t_{WCS} \geq t_{WCS} (MIN)$ , the cycle is an EARLY WRITE cycle and the data output will remain an open circuit throughout the entire cycle. If  $t_{WCS} < t_{WCS} (MIN)$  and  $t_{RWD} \geq t_{RWD} (MIN)$ ,  $t_{AWD} \geq t_{AWD} (MIN)$  and  $t_{CWD} \geq t_{CWD} (MIN)$ , the cycle is a READ-MODIFY-WRITE and the data output will contain data read from the selected cell. If neither of the above conditions is met, the state of data-out is indeterminate.  $\overline{OE}$  held HIGH and  $\overline{WE}$  taken LOW after  $\overline{CAS}$  goes LOW results in a LATE WRITE ( $\overline{OE}$ -controlled) cycle.  $t_{WCS}$ ,  $t_{RWD}$ ,  $t_{CWD}$  and  $t_{AWD}$  are not applicable in a LATE WRITE cycle.
21. These parameters are referenced to  $\overline{CAS}$  leading edge in EARLY WRITE cycles and  $\overline{WE}$  leading edge in LATE WRITE or READ-MODIFY-WRITE cycles.
22. If  $\overline{OE}$  is tied permanently LOW, LATE WRITE or READ-MODIFY-WRITE operations are not permissible and should not be attempted. Additionally,  $\overline{WE}$  must be pulsed during  $\overline{CAS}$  HIGH time in order to place I/O buffers in High-Z.
23. A HIDDEN REFRESH may also be performed after a WRITE cycle. In this case,  $\overline{WE} = LOW$  and  $\overline{OE} = HIGH$ .
24.  $t_{WTS}$  and  $t_{WTH}$  are setup and hold specifications for the  $\overline{WE}$  pin being held LOW to enable the JEDEC test mode (with CBR timing constraints). These two parameters are the inverts of  $t_{WRP}$  and  $t_{WRH}$  in the CBR REFRESH cycle.





READ CYCLE

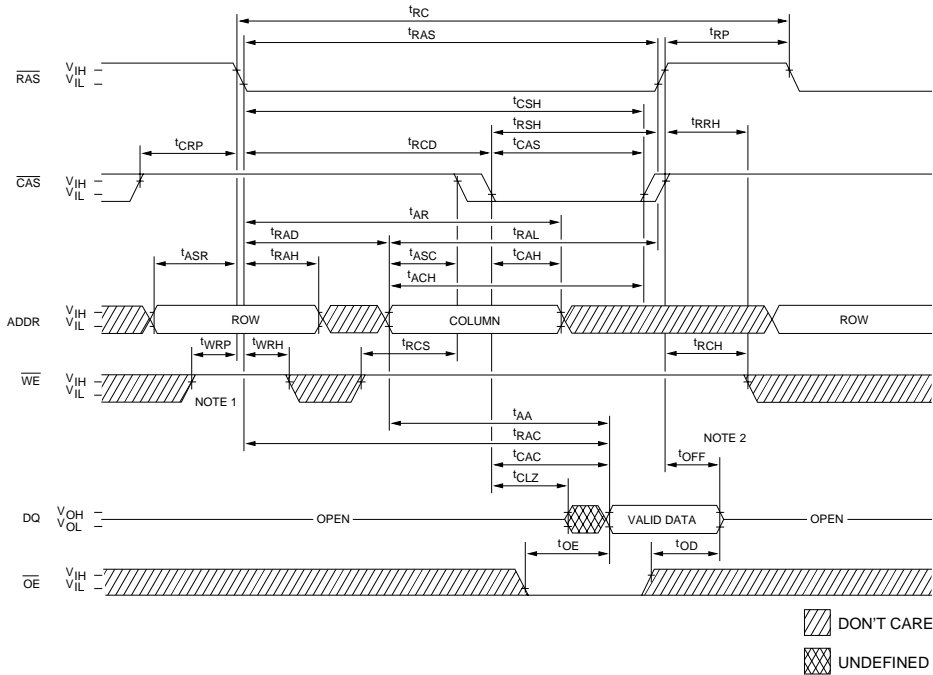

- NOTE:**
- Although  $\overline{WE}$  is a "don't care" at  $\overline{RAS}$  time during an access cycle (READ or WRITE), the system designer should implement  $\overline{WE}$  HIGH for  $t_{WRP}$  and  $t_{WRH}$ . This design implementation will facilitate compatibility with future EDO DRAMs.
  - $t_{OFF}$  is referenced from rising edge of  $\overline{RAS}$  or  $\overline{CAS}$ , whichever occurs last.

TIMING PARAMETERS

SYM	-6		-7		-8		UNITS
	MIN	MAX	MIN	MAX	MIN	MAX	
$t_{AA}$		30		35		40	ns
$t_{ACH}$	15		15		20		ns
$t_{AR}$	45		50		60		ns
$t_{ASC}$	0		0		0		ns
$t_{ASR}$	0		0		0		ns
$t_{CAC}$		15		20		20	ns
$t_{CAH}$	10		15		15		ns
$t_{CAS}$	12	10,000	15	10,000	20	10,000	ns
$t_{CLZ}$	0		0		0		ns
$t_{CRP}$	5		5		5		ns
$t_{CSH}$	50		55		60		ns
$t_{OD}$	0	15	0	15		20	ns
$t_{OE}$		15		20		20	ns
$t_{OFF}$	0	15	0	15	0	20	ns

SYM	-6		-7		-8		UNITS
	MIN	MAX	MIN	MAX	MIN	MAX	
$t_{RAC}$		60		70		80	ns
$t_{RAD}$	15	30	15	35	15	40	ns
$t_{RAH}$	10		10		10		ns
$t_{RAL}$	30		35		40		ns
$t_{RAS}$	60	10,000	70	10,000	80	10,000	ns
$t_{RC}$	110		130		150		ns
$t_{RCD}$	16	45	16	50	20	60	ns
$t_{RCH}$	0		0		0		ns
$t_{RCS}$	0		0		0		ns
$t_{RP}$	40		50		60		ns
$t_{RRH}$	0		0		0		ns
$t_{RSH}$	10		12		15		ns
$t_{WRH}$	10		10		10		ns
$t_{WRP}$	10		10		10		ns



EARLY WRITE CYCLE

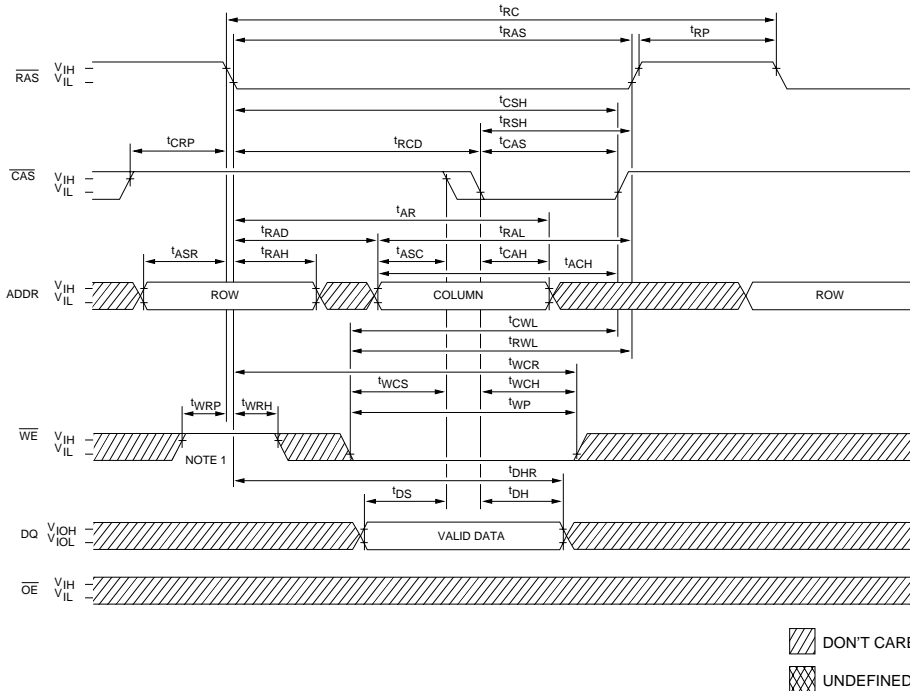

**NOTE:** 1. Although  $\overline{WE}$  is a "don't care" at  $\overline{RAS}$  time during an access cycle (READ or WRITE), the system designer should implement  $\overline{WE}$  HIGH for  $t_{WRP}$  and  $t_{WRH}$ . This design implementation will facilitate compatibility with future EDO DRAMs.

TIMING PARAMETERS

SYM	-6		-7		-8		UNITS
	MIN	MAX	MIN	MAX	MIN	MAX	
$t_{ACH}$	15		15		20		ns
$t_{AR}$	45		55		60		ns
$t_{ASC}$	0		0		0		ns
$t_{ASR}$	0		0		0		ns
$t_{CAH}$	10		15		15		ns
$t_{CAS}$	12	10,000	15	10,000	20	10,000	ns
$t_{CRP}$	5		5		5		ns
$t_{CSH}$	50		55		60		ns
$t_{CWL}$	15		15		20		ns
$t_{DH}$	10		12		15		ns
$t_{DHR}$	40		50		55		ns
$t_{DS}$	0		0		0		ns
$t_{RAD}$	15	30	15	35	15	40	ns
$t_{RAH}$	10		10		10		ns

SYM	-6		-7		-8		UNITS
	MIN	MAX	MIN	MAX	MIN	MAX	
$t_{RAL}$	30		35		40		ns
$t_{RAS}$	60	10,000	70	10,000	80	10,000	ns
$t_{RC}$	110		130		150		ns
$t_{RCD}$	16	45	16	50	20	60	ns
$t_{RP}$	40		50		60		ns
$t_{RSH}$	13		15		0		ns
$t_{RWL}$	15		15		20		ns
$t_{WCH}$	10		12		15		ns
$t_{WCR}$	40		50		60		ns
$t_{WCS}$	0		0		0		ns
$t_{WP}$	10		12		15		ns
$t_{WRH}$	10		10		10		ns
$t_{WRP}$	10		10		10		ns



**READ WRITE CYCLE**  
(LATE WRITE and READ-MODIFY-WRITE cycles)

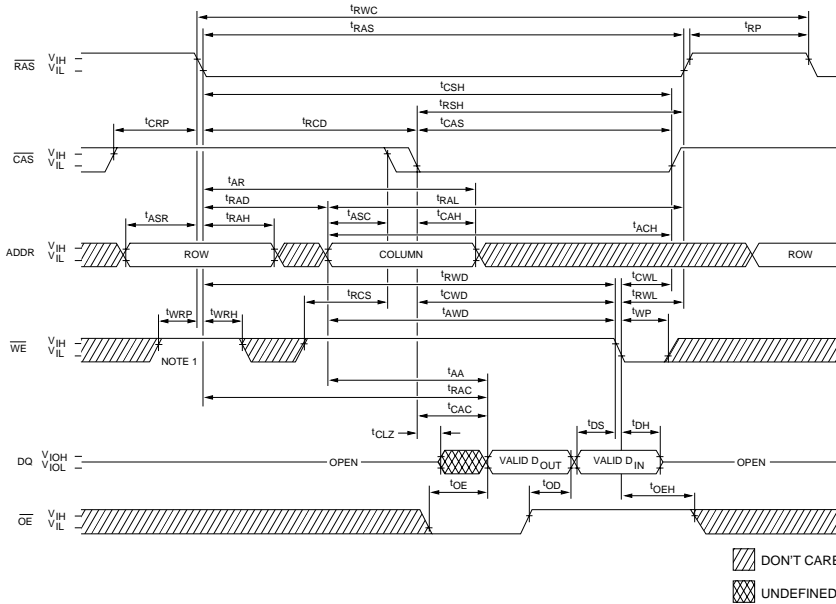

**NOTE:** 1. Although  $\overline{WE}$  is a "don't care" at  $\overline{RAS}$  time during an access cycle (READ or WRITE), the system designer should implement  $\overline{WE}$  HIGH for  $tWRP$  and  $tWRH$ . This design implementation will facilitate compatibility with future EDO DRAMs.

**TIMING PARAMETERS**

SYM	-6		-7		-8		UNITS
	MIN	MAX	MIN	MAX	MIN	MAX	
tAA		30		35		40	ns
tACH	15		15		20		ns
tAR	45		55		60		ns
tASC	0		0		0		ns
tASR	0		0		0		ns
tAWD	55		65		65		ns
tCAC		15		20		20	ns
tCAH	10		15		15		ns
tCAS	12	10,000	15	10,000	20	10,000	ns
tCLZ	0		0		0		ns
tCRP	5		5		5		ns
tCSH	50		55		60		ns
tCWD	35		40		45		ns
tCWL	15		15		20		ns
tDH	10		12		15		ns
tDS	0		0		0		ns
tOD	0	15	0	15	0	20	ns

SYM	-6		-7		-8		UNITS
	MIN	MAX	MIN	MAX	MIN	MAX	
tOE		15		20		20	ns
tOEH	10		12		15		ns
tRAC		60		70		80	ns
tRAD	15	30	15	35	15	40	ns
tRAH	10		10		10		ns
tRAL	30		35		40		ns
tRAS	60	10,000	70	10,000	80	10,000	ns
tRCD	16	45	16	50	20	60	ns
tRCS	0		0		0		ns
tRP	40		50		60		ns
tRSH	13		15		15		ns
tRWC	150		180		200		ns
tRWD	80		90		105		ns
tRWL	15		15		20		ns
tWP	10		12		15		ns
tWRH	10		10		10		ns
tWRP	10		10		10		ns





EDO-PAGE-MODE EARLY-WRITE CYCLE

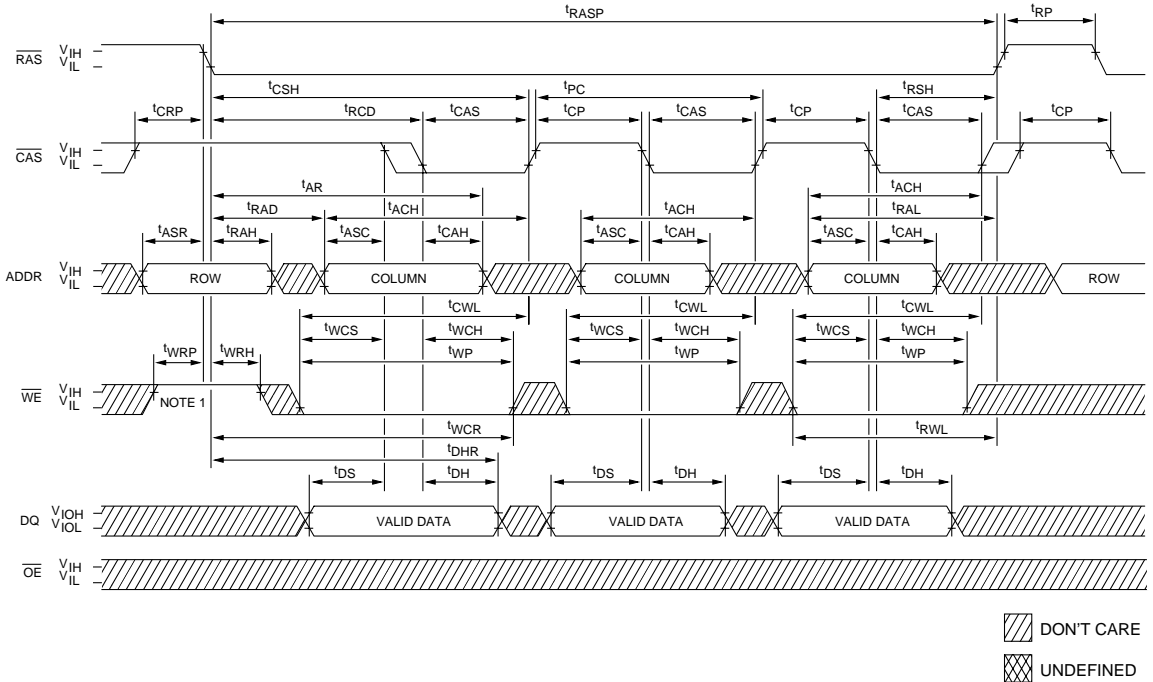

**NOTE:** 1. Although  $\overline{WE}$  is a "don't care" at  $\overline{RAS}$  time during an access cycle (READ or WRITE), the system designer should implement  $\overline{WE}$  HIGH for  $t_{WRP}$  and  $t_{WRH}$ . This design implementation will facilitate compatibility with future EDO DRAMs.

TIMING PARAMETERS



	-6		-7		-8		
SYM	MIN	MAX	MIN	MAX	MIN	MAX	UNITS
$t_{ACH}$	15		15		20		ns
$t_{AR}$	45		55		60		ns
$t_{ASC}$	0		0		0		ns
$t_{ASR}$	0		0		0		ns
$t_{CAH}$	10		12		15		ns
$t_{CAS}$	12	10,000	15	10,000	20	10,000	ns
$t_{CP}$	10		10		10		ns
$t_{CRP}$	5		5		5		ns
$t_{CSH}$	50		55		60		ns
$t_{CWL}$	15		15		20		ns
$t_{DH}$	10		12		15		ns
$t_{DHR}$	40		50		55		ns
$t_{DS}$	0		0		0		ns
$t_{PC}$	30		35		40		ns

	-6		-7		-8		
SYM	MIN	MAX	MIN	MAX	MIN	MAX	UNITS
$t_{RAD}$	15	30	15	35	15	40	ns
$t_{RAH}$	10		10		10		ns
$t_{RAL}$	30		35		40		ns
$t_{RASP}$	60	100,000	70	100,000	80	100,000	ns
$t_{RCD}$	16	45	16	50	20	60	ns
$t_{RP}$	40		50		60		ns
$t_{RSH}$	13		15		15		ns
$t_{RWL}$	15		15		20		ns
$t_{WCH}$	10		12		15		ns
$t_{WCR}$	40		50		60		ns
$t_{WCS}$	0		0		0		ns
$t_{WP}$	10		12		15		ns
$t_{WRH}$	10		10		10		ns
$t_{WRP}$	10		10		10		ns

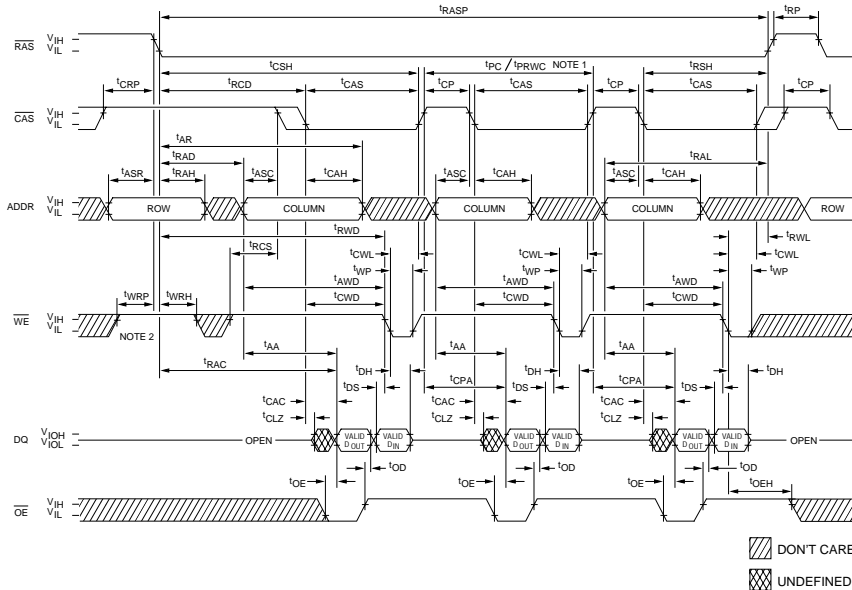

EDO-PAGE-MODE READ-WRITE CYCLE  
(LATE WRITE and READ-MODIFY-WRITE cycles)



 DONT CARE  
 UNDEFINED

- NOTE:**
1.  $t_{PC}$  is for LATE WRITE cycles only.
  2. Although  $\overline{WE}$  is a "don't care" at RAS time during an access cycle (READ or WRITE), the system designer should implement  $\overline{WE}$  HIGH for  $t_{WRP}$  and  $t_{WRH}$ . This design implementation will facilitate compatibility with future EDO DRAMS.

**TIMING PARAMETERS**

	-6		-7		-8		
SYM	MIN	MAX	MIN	MAX	MIN	MAX	UNITS
$t_{AA}$		30		35		40	ns
$t_{AR}$	45		55		60		ns
$t_{ASC}$	0		0		0		ns
$t_{ASR}$	0		0		0		ns
$t_{AWD}$	55		65		65		ns
$t_{CAC}$		15		20		20	ns
$t_{CAH}$	10		15		15		ns
$t_{CAS}$	12	10,000	15	10,000	20	10,000	ns
$t_{CLZ}$	0		0		0		ns
$t_{CP}$	10		10		10		ns
$t_{CPA}$		35		40		40	ns
$t_{CRP}$	5		5		5		ns
$t_{CSH}$	50		55		60		ns
$t_{CWD}$	35		40		45		ns
$t_{CWL}$	15		15		20		ns
$t_{DH}$	10		12		15		ns
$t_{DS}$	0		0		0		ns
$t_{OD}$	0	15	0	15	0	20	ns

	-6		-7		-8		
SYM	MIN	MAX	MIN	MAX	MIN	MAX	UNITS
$t_{OE}$		15		20		20	ns
$t_{OEh}$	10		12		15		ns
$t_{PC}$	30		35		40		ns
$t_{PRWC}$		75		85		90	ns
$t_{RAD}$		60		70		80	ns
$t_{RAD}$	15	30	15	35	15	40	ns
$t_{RAH}$	10		10		10		ns
$t_{RAL}$	30		35		40		ns
$t_{RASP}$	60	100,000	70	100,000	80	100,000	ns
$t_{RCD}$	16	45	16	50	20	60	ns
$t_{RCS}$	0		0		0		ns
$t_{RP}$	40		50		60		ns
$t_{RSH}$	13		15		15		ns
$t_{RWD}$	80		90		105		ns
$t_{RWL}$	15		15		20		ns
$t_{WP}$	10		12		15		ns
$t_{WRH}$	10		10		10		ns
$t_{WRP}$	10		10		10		ns





**READ CYCLE**  
(with WE-controlled disable)

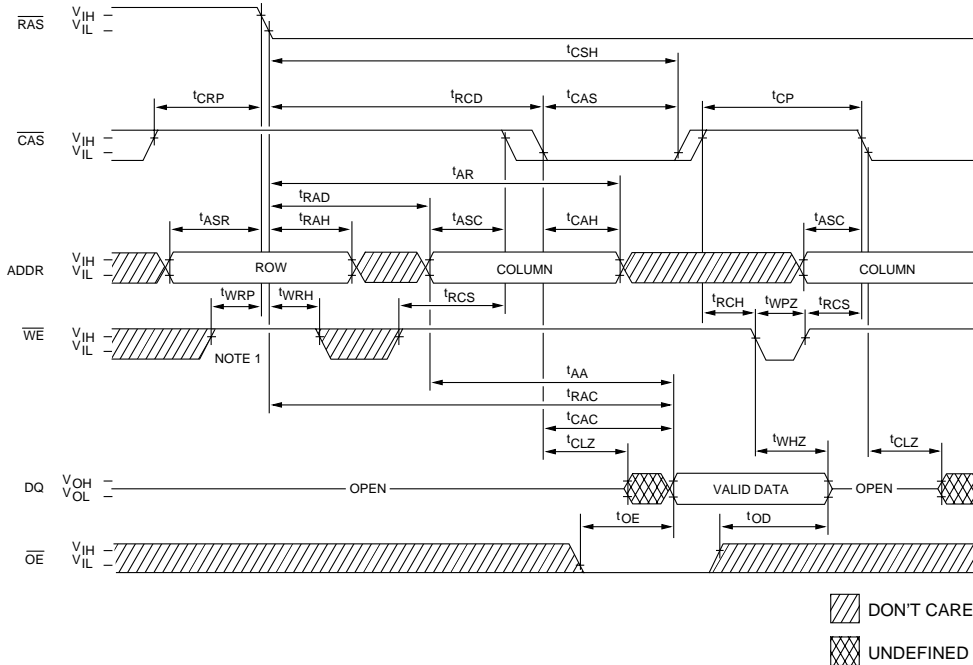

**NOTE:** 1. Although  $\overline{WE}$  is a "don't care" at  $\overline{RAS}$  time during an access cycle (READ or WRITE), the system designer should implement  $\overline{WE}$  HIGH for  $t_{WRP}$  and  $t_{WRH}$ . This design implementation will facilitate compatibility with future EDO DRAMs.

**TIMING PARAMETERS**

	-6		-7		-8		
SYM	MIN	MAX	MIN	MAX	MIN	MAX	UNITS
$t_{AA}$		30		35		40	ns
$t_{AR}$	45		55		60		ns
$t_{ASC}$	0		0		0		ns
$t_{ASR}$	0		0		0		ns
$t_{CAC}$		15		20		20	ns
$t_{CAH}$	10		15		15		ns
$t_{CAS}$	12	10,000	15	10,000	20	10,000	ns
$t_{CLZ}$	0		0		0		ns
$t_{CP}$	10		10		10		ns
$t_{CRP}$	5		5		5		ns
$t_{CSH}$	50		55		60		ns
$t_{OD}$	0	15	0	15	0	20	ns

	-6		-7		-8		
SYM	MIN	MAX	MIN	MAX	MIN	MAX	UNITS
$t_{OE}$		15		20		20	ns
$t_{RAC}$		60		70		80	ns
$t_{RAD}$	15	30	15	35	15	40	ns
$t_{RAH}$	10		10		10		ns
$t_{RCD}$	16	45	16	50	20	60	ns
$t_{RCH}$	0		0		0		ns
$t_{RCS}$	0		0		0		ns
$t_{WHZ}$	0	14	0	16	0	20	ns
$t_{WPZ}$	10		12		15		ns
$t_{WRH}$	10		10		10		ns
$t_{WRP}$	10		10		10		ns





**RAS-ONLY REFRESH CYCLE**

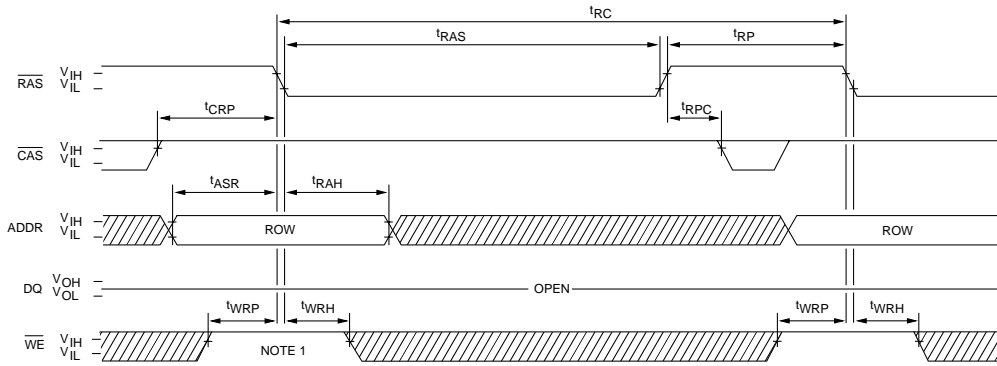

**CBR REFRESH CYCLE**  
(Addresses and  $\overline{OE}$  = DON'T CARE)

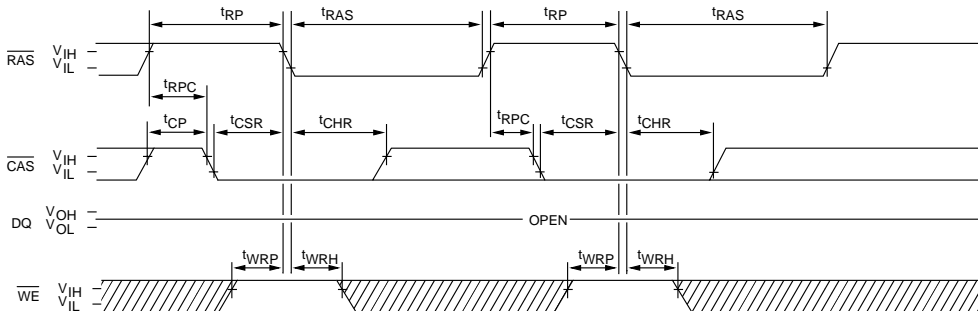

DON'T CARE  
 UNDEFINED

**NOTE:** 1. Although  $\overline{WE}$  is a "don't care" at  $\overline{RAS}$  time during an access cycle (READ or WRITE), the system designer should implement  $\overline{WE}$  HIGH for  $t_{WRP}$  and  $t_{WRH}$ . This design implementation will facilitate compatibility with future EDO DRAMs.

**TIMING PARAMETERS**

	-6		-7		-8		
SYM	MIN	MAX	MIN	MAX	MIN	MAX	UNITS
$t_{ASR}$	0		0		0		ns
$t_{CHR}$	10		15		15		ns
$t_{CP}$	10		10		10		ns
$t_{CRP}$	5		5		5		ns
$t_{CSR}$	5		5		10		ns
$t_{RAH}$	10		10		10		ns

	-6		-7		-8		
SYM	MIN	MAX	MIN	MAX	MIN	MAX	UNITS
$t_{RAS}$	60	10,000	70	10,000	80	10,000	ns
$t_{RC}$	110		130		150		ns
$t_{RP}$	40		50		60		ns
$t_{RPC}$	5		5		5		ns
$t_{WRH}$	10		10		10		ns
$t_{WRP}$	10		10		10		ns



**HIDDEN REFRESH CYCLE<sup>24</sup>**  
(WE = HIGH; OE = LOW)

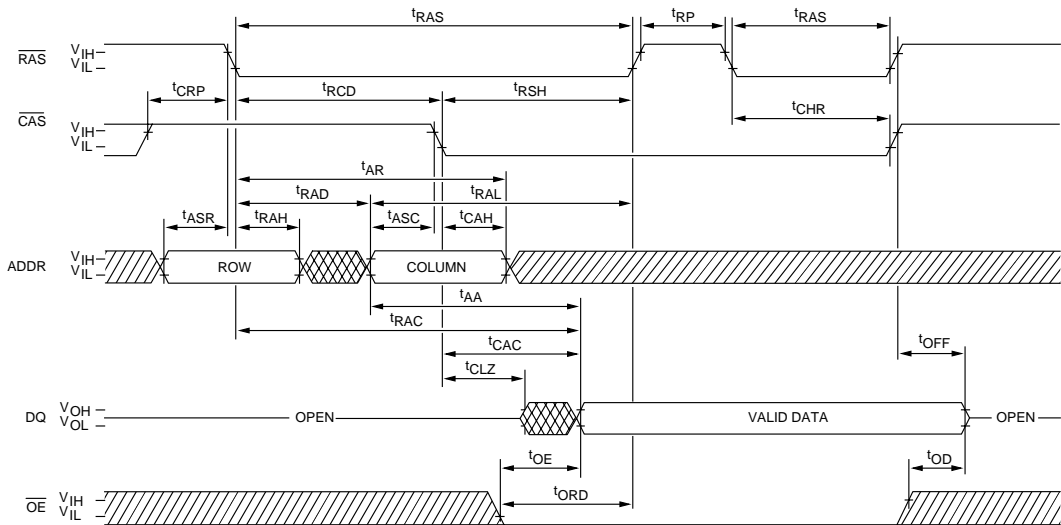

DON'T CARE  
 UNDEFINED

**TIMING PARAMETERS**

	-6		-7		-8		
SYM	MIN	MAX	MIN	MAX	MIN	MAX	UNITS
t <sub>AA</sub>		30	35		40		ns
t <sub>AR</sub>	45		55		60		ns
t <sub>ASC</sub>	0		0		0		ns
t <sub>ASR</sub>	0		0		0		ns
t <sub>CAC</sub>		15	20		20		ns
t <sub>CAH</sub>	10		15		15		ns
t <sub>CHR</sub>	10		15		15		ns
t <sub>CLZ</sub>	0		0		0		ns
t <sub>CRP</sub>	5		5		5		ns
t <sub>OD</sub>	0	15	0	15	0	20	ns
t <sub>OE</sub>		15	20		20		ns

	-6		-7		-8		
SYM	MIN	MAX	MIN	MAX	MIN	MAX	UNITS
t <sub>OFF</sub>	0	15	0	15	0	20	ns
t <sub>ORD</sub>	0		0		0		ns
t <sub>RAC</sub>		60		70		80	ns
t <sub>RAH</sub>	15	30	15	35	15	40	ns
t <sub>RAL</sub>	10		10		10		ns
t <sub>RAS</sub>	30		35		40		ns
t <sub>RAS</sub>	60	10,000	70	10,000	80	10,000	ns
t <sub>RCD</sub>	16	45	16	50	20	60	ns
t <sub>RP</sub>	40		50		60		ns
t <sub>RSH</sub>	13		15		15		ns



**ELECTRICAL TEST REQUIREMENTS**

MIL-STD-883 TEST REQUIREMENTS	SUBGROUPS (per Method 5005, Table I)
INTERIM ELECTRICAL (PRE-BURN-IN) TEST PARAMETERS (Method 5004)	2, 8A, 10
FINAL ELECTRICAL TEST PARAMETERS (Method 5004)	1*, 2, 3, 7*, 8, 9, 10, 11
GROUP A TEST REQUIREMENTS (Method 5005)	1, 2, 3, 4**, 7, 8, 9, 10, 11
GROUP C AND D END-POINT ELECTRICAL PARAMETERS (Method 5005)	1, 2, 3, 7, 8, 9, 10, 11

\* PDA applies to subgroups 1 and 7.

\*\* Subgroup 4 shall be measured only for initial qualification and after process or design changes, which may affect input or output capacitance.

