

AS5410

3D-Hall Encoder absolute linear

1 General Description

The chip can measure magnetic fields components in all three dimensions and converts the magnetic field information into absolute, position information. The AS5410 supports absolute linear position measurement applications.

Only a simple 2-pole magnet is required as the magnetic field source.

Using two 3D-Hall cells allows both absolute as well as differential 3D magnetic field measurement.

The differential measurement makes the AS5410 ideal for use in rough industrial position sensing applications that include not only dust, dirt or moisture but also unwanted magnetic fields.

All the signal conditioning, including compensation of temperature effects, magnet-to-chip gap changes as well as linearization of the output is included in the IC.

The absolute position information of the magnet is directly accessible over a SPI interface and PWM output. A cycle redundancy check (CRC) allows verification of the received data.

The AS5410 is available in a 14-pin TSSOP package and is qualified for an ambient temperature range from -40°C to +105°C.

It operates at a supply voltage of 3.3V +/-10%.

2 Key Features

- up to 14-bit full scale resolution
- SPI and PWM output
- Wide magnetic input range
- 33 linearization points to achieve high precision
- Absolute linear position sensing up to 50 mm stroke
- Suppression of magnetic stray fields
- Low power operation

3 Applications

- Plunger positioning
- Pedal positioning
- Pneumatic and hydraulic cylinder positioning
- Automation with linear positioning stages through cascading of several AS5410's

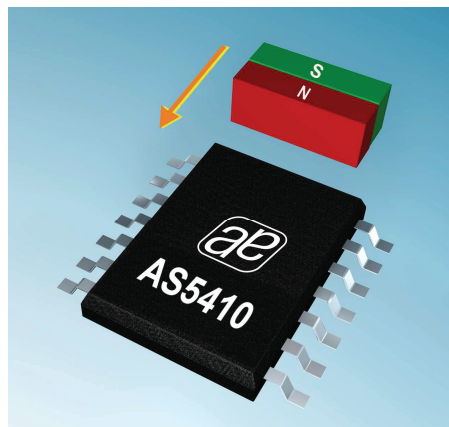

Figure 1 AS5410 linear position sensing of the magnet

4 Block Diagram

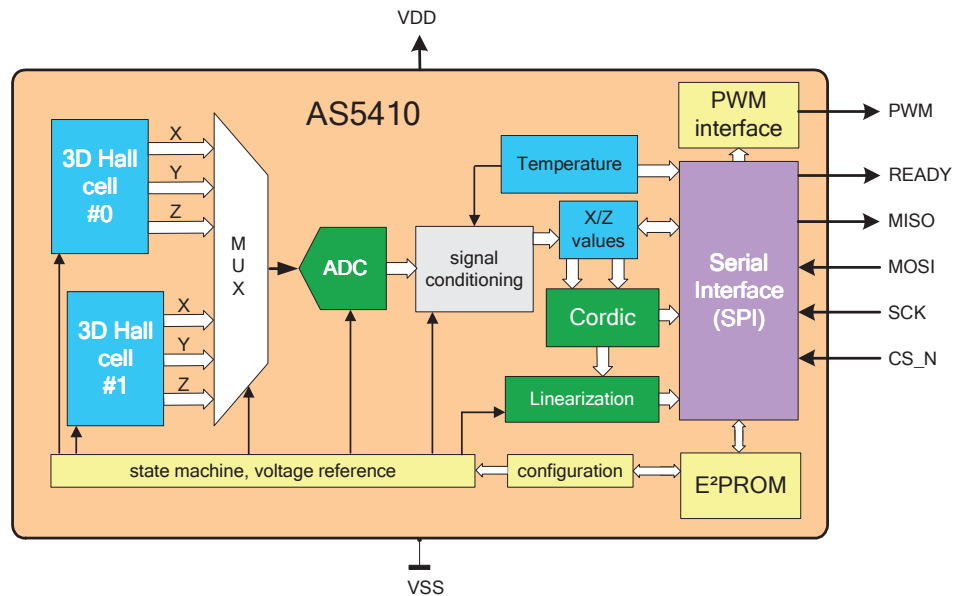

Figure 2: Blockdiagram AS5410

3D Hall cells:	The AS5410 contains two 3D Hall cells, spaced 2.5mm apart.
MUX:	The Multiplexer selects two magnetic fields as the inputs for the CORDIC. The selected inputs can either be absolute sensor signals or differential sensor signals
ADC:	The Sigma-Delta ADC samples the Hall sensors signals selected by the MUX. The sampling of the sensors is done sequentially
Signal conditioning:	This block includes offset and temperature compensation as well as amplitude matching
X/Z values:	registers containing the input sensor signals of the cordic inputs
Cordic:	Coordinate to Rotation Digital Computer: this block converts rectangular coordinates (sine and cosine signals from the Hall sensors) into polar coordinates (angle/distance and magnitude)
Linearization:	A 33-point linearization of the CORDIC output data is available to accommodate a variety of different magnet sizes and applications.
Temperature:	An on-chip temperature sensor is available. It can be read over the SPI interface. This sensor is also used for signal conditioning
PWM interface:	The linearized measurement data is available over a single pin in the form of a pulse width modulated (PWM) signal.
SPI interface:	A bi-directional SPI interface allows communication with the chip, including reading measurement data, E ² PROM contents or writing configuration data
E ² PROM:	The on-chip E ² PROM contains the configuration data of the chip.
State machine:	The state machine controls the automatic sequencing of measurements. Once it is configured for a certain measurement, the state machine executes all necessary steps to perform a complete measurement cycle.
Configuration:	The configuration is pre-defined in the AS5410.

5 Pinout

5.1 Pin Assignments

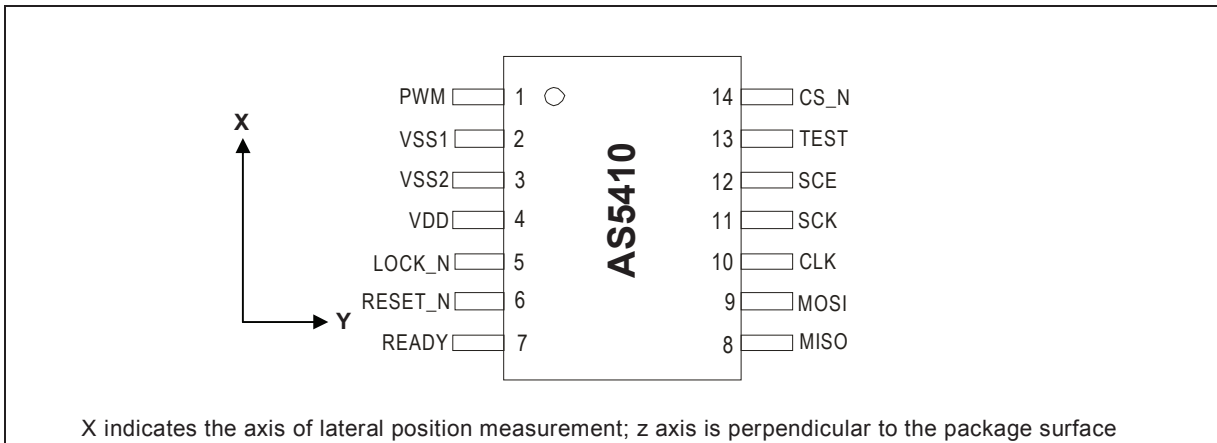

Figure 3: AS5410 pin configuration, TSSOP-14package (top view)

5.2 Sensor Placement

Two pixel cells each with an X-/Y-/Z-Sensor are arranged in a line on the X Axis parallel to the chip edge, 2.5mm distant from each other.

Pixel positions relative to chip centre are:

Pixel 0: -1250 mm

Pixel 1: 1250 mm

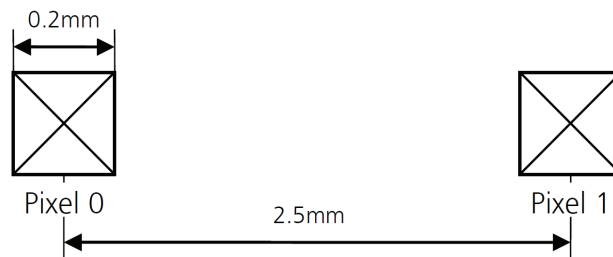

Figure 4: Pixel cell arrangement

5.3 Pin Description

Table 1 Pin description

Pin TSSOP	Symbol	Type	Description
1	PWM	DO	PWM output. The linearized output data is available on this pin.
2	VSS2	S	Ground (0V) Note: both VSS1 and VSS2 must be connected
3	VSS1	S	Ground (0V) Note: both VSS1 and VSS2 must be connected
4	VDD	S	Positive supply voltage (3.0 3.6V)
5	LOCK_N	DI_ST	Test pin, must be connected to VSS in normal operation
6	RESET_N	DI_ST	Reset input (active low)
7	READY	DO	Measurement ready signal is set high when a measurement cycle is completed and the results in the output registers are valid
8	MISO	DO_T	Master in / Slave out (SPI interface data output)
9	MOSI	DI_ST	Master out / Slave in (SPI interface data input)
10	CLK	DIO	Must be connected to VSS.
11	SCK	DI_ST	SPI interface clock input (max. 16 MHz)
12	SCE	DI_ST	Test pin, must be connected to VSS in normal operation
13	TEST	DI_ST	Test pin, must be connected to VSS in normal operation
14	CS_N	DI_ST	Chip select (active low)

AIO analog input/output
 DO digital output
 DIO digital input & output
 DI_ST digital Schmitt-Trigger input
 DO_T digital output /tri-state
 S supply pin

Notes:

- 1) CS_N is active low and activates data transmission. If only a single device is used, CS_N may remain low for several commands, for example while reading the output registers.

5.4 Power modes

The AS5410 can be configured for two power modes:

- Continuous mode
- Single shot mode

5.4.1 Continuous mode

In this mode, the AS5410 is always active. The chip continuously updates the output registers. The completion of a new measurement is signalled with pin READY.

5.4.2 Single shot mode

The AS5410 features an automatic power down mode. After completion of a measurement, the chip automatically suspends to standby. The SPI interface remains active. The control of this mode is possible over register 000Eh (see chapter 8). A high on the Ready output indicates that a measurement is completed. The AS5410 suspends to stand-by state after the Ready output has been set.

Electrical Characteristics

5.5 Absolute Maximum Ratings

Stresses beyond those listed under “Absolute Maximum Ratings“ may cause permanent damage to the device. These are stress ratings only. Functional operation of the device at these or any other conditions beyond those indicated under “Operating Conditions“ is not implied. Exposure to absolute maximum rating conditions for extended periods may affect device reliability.

Table 2 Absolute maximum ratings

Parameter	Min	Max	Unit	Comments
DC supply voltage at pin VDD		5	V	
Input pin voltage	-0.3	VDD +0.3	V	
Input current (latchup immunity)	-100	100	mA	Norm: JEDEC 78
Electrostatic discharge		± 2	kV	Norm: MIL 883 E method 3015
Storage temperature	-55	150	°C	Min – 67°F ; Max +25 7°F
Body temperature		260	°C	IPC/JEDEC J-Std-020C Lead finish 100% Sn “matte tin”
Humidity non-condensing	5	85	%	
Moisture Sensitive Level (MSL)		3		Represents a maximum floor time of 168h
EEPROM read/write cycles		100	cycles	

5.6 Operating Conditions

Table 3 Electrical characteristics

Operating conditions: operating temperature = -40 to +105°C, VDD = 3.0-3.6V unless otherwise no ted.

Parameter	Symbol	Min	Typ	Max	Unit	Note
Positive Supply voltage	VDD	3.0	3.3	3.6	V	
Supply current	I _{supp}		15		mA	Active operation, continuous mode
Operating ambient temperature	T	-40		+105	°C	-40°F...+185°F
Internal oscillator frequency	f _{osc}		8		MHz	
wake up time	twu		2		ms	from cold start
	twlp			200	µs	from standby; see 5.4.2

Note: ¹⁾ the conversion time is based on a single phase measurement of one X, Y- or Z sensor. .

5.7 Performance specifications

The AS5410 can be used in linear applications. Shown in 5.7.1 is an example of an absolute linear displacement sensor for a stroke of 40mm, using Hall elements X0 + X1 (differential) and Z0 + Z1 (differential). The reference magnet used for this application is described in 5.7.2.

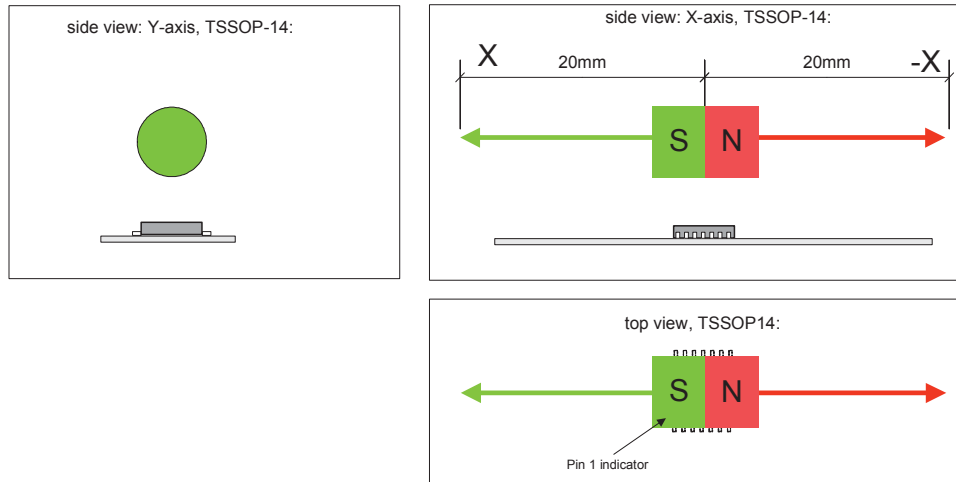

Figure 5: Reference setup for absolute linear displacement measurement

5.7.1 System performance specifications

Operating conditions: magnet placement as specified in Figure , operating temperature = -40 to 105°C, VDD = 3.0-3.6V unless otherwise noted.

Table 4 System Parameters

Parameter	Symbol	Min	Typ	Max	Unit	Note
Lateral stroke	d_x	-20		20	mm	using the magnet specified in Figure
Signal amplitude, Bx		-60		60	mT	
Signal amplitude, By		-60		60	mT	
Signal amplitude, Bz		-50		50	mT	
Resolution	res			14	Bit	@ 40mm stroke
Sampling rate configuration 0 ¹⁾	Ts		1		ms	normal mode
Sampling rate configuration 1 ¹⁾	Ts		2		ms	slow mode
Accuracy ²⁾	acc _{v0}		0.25		%	@ v=0 m/s, 40mm stroke, tamb = 25°C
			0.1		mm	
	acc _{v1}	-0.5		0.5	%	@ v=0 m/s, 40mm stroke, tj = -40 to +105°C
		-0.2		0.2	mm	
	acc _{vmax}	-2.5		2.5	%	@ v = 1 m/s, 40mm stroke tamb = 25°C
		-1		1	mm	
acc _{vmax} _x	-6.5		6.5	%	@ v = v _{max} = 3 m/s, 40mm stroke tamb = 25°C	
	-2.5		2.5	mm		

Note:

¹⁾ configurable in register 000Bh

²⁾ The accuracy data is based on an averaged reading (excluding noise) of the displacement value compared to an absolute reference. Note that with a moving magnet the accuracy is reduced due to the sequential sampling of the Hall sensors and the conversion time of the ADC. The accuracy values shown in this table are valid for room temperature.

5.7.2 Noise performance specifications

Operating conditions: ambient temperature = 25°C, VDD = 3.0-3.6V

Table 5 Input referred noise

Parameter	Symbol	Min	Typ	Max	Unit	Note
Input referred noise ¹⁾	noise _{IN}		38	77	μT	3 sigma

Note: 1) AS5410 configuration and setup:

- absolute measurement of Bx and By
- magnetic fields: Bx = 2.5mT, By = 2.5mT (45° CORDIC angle)
- measurement update rate: 1kHz (factory default setting)

5.8 DC Characteristics for Digital Inputs and Outputs

5.8.1 CMOS Schmitt-Trigger Inputs: LOCK_N, RESET_N, CLK, MOSI, SCK, CS_N, Test, SCE

Operating conditions: operating temperature = -40 to +105°C, VDD = 3.0-3.6V unless otherwise noted.

Parameter	Symbol	Min	Max	Unit	Note
High level input voltage	VIH	1.77	1.87	V	VDD = 3.0V
		2.07	2.23		VDD = 3.6V
Low level input voltage	VIL	1.12	1.27	V	VDD = 3.0V
		1.42	1.52		VDD = 3.6V
Input current	I _{in}		10	mA	for Vin > VDD ¹⁾

Note: ¹⁾ Input pin voltages higher than VDD (e.g. 5V TTL levels) must be limited by a series resistor to ensure that the maximum input current (I_{in}) is not exceeded.

5.8.2 CMOS Outputs: READY, MISO, PWM

Operating conditions: operating temperature = -40 to +105°C, VDD = 3.0-3.6V unless otherwise noted.

Parameter	Symbol	Min	Max	Unit	Note
Output high level	VO _H	2.5	VDD	V	
Output current, source	IO _H		8	mA	
Output low level	VO _L	0	0.4	V	
Output current, sink	IO _L		8	mA	

5.8.3 Power On reset

Operating conditions: operating temperature = -40 to +105°C

Parameter	Symbol	Min	Typ	Max	Unit	Note
Reset threshold; VDD level rising	V _{on}	1.24	2.26	2.82	V	
Reset threshold; VDD level falling	V _{off}	1.13		2.67	V	

5.9 On-chip temperature measurement

The AS5410 provides a linear on-chip temperature sensor which is used for automatic compensation of sensitivity and offset drifts for the Hall-In-One sensors.

The measured chip temperature is available in a register (0110h) and can be used for monitoring purposes

Operating conditions: operating temperature = -40 to +105°C

Parameter	Symbol	Min	Typ	Max	Unit	Note
Temperature signal at 25°	D _{temp}		0		LSB	
Resolution	ReS _{temp}	185	200	210	LSB/K	

6 Serial Interface (SPI)

The SPI interface provides data transfer between AS5410 and the external microcontroller.

The Interface is conform to the SPI standard.

Note that SPI bus is a de facto standard, rather than one agreed by any international committee.

The minimum number of connections between microcontroller and AS5410 is three:

- 1) MOSI: Master Out – Slave In; data transfer from microcontroller to AS5410 (Write)
- 2) MISO: Master In – Slave Out; data transfer from AS5410 to microcontroller (Read)
- 3) SCK: Serial clock; Data is written and read with the rising edge of SCK

Optionally, two further connections may be used:

- 1) CS_N: Chip select; this connection is mandatory when multiple AS5410 devices are connected in parallel. In electrically “noisy” environment it is recommended to use the CS_N connection in order to maintain safe data transfer.

For a single unit, this connection is optional as the data transmission is synchronized automatically by the number of SCK cycles. In this case it is recommended to verify the synchronization by CRC (see **Error! Reference source not found.**), Data readback (Figure) or repeated reading and cross-checking of subsequent measurements.

- 2) Ready: this output indicates when data is ready, it is cleared by reading data from address 0100h or 0122h

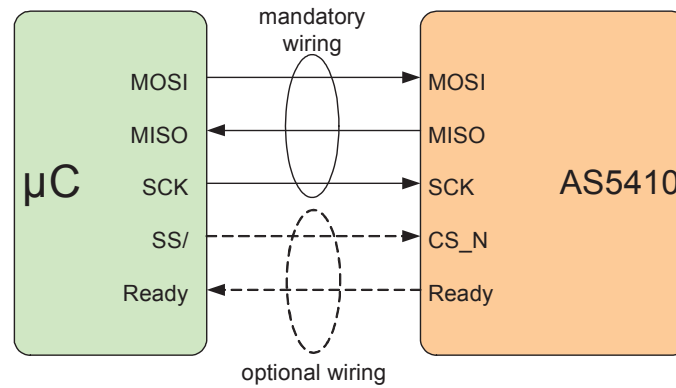

Figure 6: Hardware connection between AS5410 and microcontroller

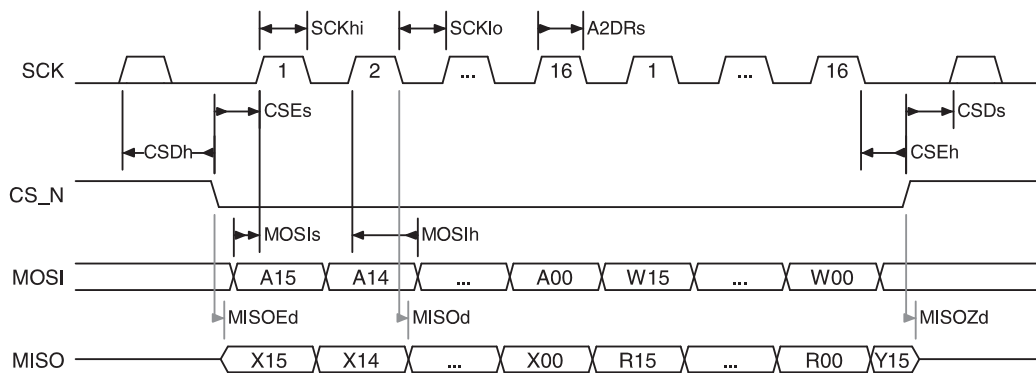

Figure 7: SPI timing diagram

The data bits sent to the chip via MOSI and the data bits received from the chip via MISO are defined as follows (see also Figure):

- A15...A00 = 16-bit register address
- W15...W00 = 16-bit write data (in write mode)
- X15...X00, Y15 = 16-bit read data or previous command (depending on mode)
- R15...R0 = 16-bit read data in read mode or previous data in write mode

Parameter	Symbol	Min	Typ	Max	Unit	Note
SCK frequency	f_{sck}	0		16	MHz	
SCK pulse width HI	t_{SCKhi}	15			ns	
SCK pulse width LO	t_{SCKlo}	15			ns	
SCK setup time before data read	t_{A2DRs}	15			ns	
CS_N enable setup time before SCK	t_{CSEs}	10			ns	
CS_N enable hold time after SCK	t_{CSEh}	10			ns	
CS_N disable setup time before SCK	t_{CSDs}	10			ns	
CS_N disable hold time after SCK	t_{CSDh}	10			ns	
MOSI setup time before SCK	t_{MOSIs}	10			ns	
MOSI hold time after SCK	t_{MOSIh}	10			ns	
MISO delay after SCK	t_{MISOd}			10	ns	
MISO enable delay after CS_N	t_{MISOEd}			10	ns	
MISO high Z delay after CS_N	t_{MISOZd}			10	ns	
Output edge rise time	t_{Or}			3	ns	
Output edge fall time	t_{Of}			3	ns	

7 Data transfer between AS5410 and Microcontroller

Data is transferred to the AS5410 via the MOSI pin (Master Out – Slave In) with the rising edge of SCK.
Data is read from the AS5410 from the MISO pin (Master In – Slave Out) with the rising edge of SCK.

The data format consists of data streams with 32 bit in length. The first 16 bits define a 16-bit address and the subsequent 16 bits contain read or write data.

The MSB of the address word $A<15>$ defines the direction of data transfer:

$A<15> = 0$ READ; data transfer from AS5410 to microcontroller; read measurement data

$A<15> = 1$ WRITE; data transfer from microcontroller to AS5410; write configuration data

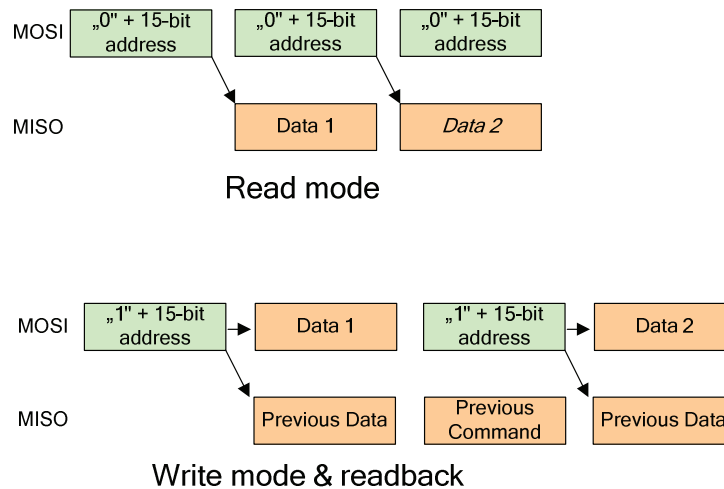

Figure 8: Data transfer between AS5410 and microcontroller

7.1 Read mode

For reading a register, the 16-bit Read address (with $A<15>=0$) is sent to the MOSI pin. After 16 SCK cycles, data of the specified address is read from the MISO pin (see Figure). At the same time, the new address may be clocked into the MOSI pin.

7.1.1 Continuous measurement

It is possible to continuously read data from the AS5410 even if a new measurement is not yet finished. In this case, the last measurement data will be read. As soon as a new measurement is completed, it will be available at the SPI interface.

7.2 Write mode & readback

For additional safety and detection of communication errors, the actual contents of a register may be read at the same time as new data is written to this register.

In case of a Write command, the 16-bit Write address (with $A<15>=1$) is sent to the MOSI pin. After 16 SCK cycles, data following the address bits is written to the specified address via MOSI in (see Figure) At the same time, the present data of that register may be read from the MISO pin. Following the 16-bit of data (Data 1 in Figure), a new address may be written to the AS5410. While the new address is written, the address from the previous command is available at the MISO output.

7.3 Checksum

To avoid reading errors, the IC calculates a Checksum at every read cycle from the register content. The Checksum value is built by an XOR operation of the previous Checksum value and the read register content. The CRC is calculated every time a register is read.

By choosing how often the Checksum is read and rechecked by the master it is possible to adjust the communication speed and safety level.

The Checksum value is stored in register 0108h (see chapter 8).

8 Register contents

The following registers can be addressed by the user via the SPI interface. Each register is 16-bit wide. Registers not listed in the table below must not be modified from their factory programmed setting.

Note: “r” are reserved bits, they must not be modified (unless otherwise noted)

8.1 Register 000Bh:

This register controls the sequencer

Register	Access	Bit	Function	Default	Note
000Bh: Sequencer control	R/W	D15 (MSB)	r	0	
		D14	r	0	
		D13	r	0	
		D12	r	0	
		D11	MgRangExt	0	“Magnet Range Extension” Enable the algorithm for an extended position range. 1 = Magnet Range Extension enabled 0 = Magnet Range Extension disabled
		D10	CoordSel	0	“Coordinate System Selection” 1 = The sign of the Lin Ang (Register 0122h) gets changed if MagDir (Register 000Bh) = 1 0 = Lin Ang (Register 0122h) gets not changed
		D9	r	0	
		D8	r	0	
		D7	Table Select 0	0	These bits allow the selection of 4 different operating modes, stored in 4 individual sequencer tables
		D6	Table Select 1	0	
		D5	MagDir	0	This Bit allows to switch the magnet direction MagDir = 0: North pole must point in +x direction (pin 7 to pin1) Default/powerup mode. MagDir = 1: North pole must point in -x direction (pin1 to pin7). Preferred orientation to permit use of CoordSel bit.
		D4	DiffMd	0	Differential mode: 0 = absolute measurement of Hall cells, 1 = differential measurement of Hall cells
		D3	r	0	
		D2	r	0	
		D1	RdyHZ	0	READY Tri-State: 0: The READY pin is always active. It must NOT be connected in parallel 1: The READY output may be connected in parallel. It is normally in high Z and only active (high) if the IC is addressed and selected. (Note: a 10k pull down resistor is mandatory at the common READY signal line if RdyHz = 1 !)
		D0 (LSB)	r	0	

	Table 0	Table 1	Table 2	Table 3
	Differential Mode 1 kHz Sample Rate	Differential Mode 0.5 kHz Sample Rate	Absolut Pixel1 1 kHz Sample Rate	Absolut Pixel1 0.5 kHz Sample Rate
Cordic Input values	Pixelcell0, Bz0 = 0x112h - Pixelcell1, Bz1 = 0x111h Pixelcell0, Bx0 = 0x114h - Pixelcell1, Bx1 = 0x113h	Pixelcell0, Bz0 = 0x112h - Pixelcell1, Bz1 = 0x111h Pixelcell0, Bx0 = 0x114h - Pixelcell1, Bx1 = 0x113h	Pixelcell1, Bz1 = 0x111h Pixelcell1, Bx1 = 0x113h	Pixelcell1, Bz1 = 0x111h Pixelcell1, Bx1 = 0x113h
Register B Settings	Table Select 1...Table Select 0 = 00 (mandatory) DiffMd = 1 (mandatory) MgRangExt = 0 or 1 depending on application	Table Select 1...Table Select 0 = 01 (mandatory) DiffMd = 1 (mandatory) MgRangExt = 0 or 1 depending on application	Table Select 1...Table Select 0 = 10 (mandatory) DiffMd = 0 (mandatory) MgRangExt = 0 (mandatory)	Table Select 1...Table Select 0 = 11 (mandatory) DiffMd = 0 (mandatory) MgRangExt = 0 (mandatory)

8.2 Register 000Dh:

Register	Access	Bit	Function	Default	Note
000Dh:	R/W	D15 (MSB)	PWMLimitHi 5	1	PWM Limit High Limits the PWM duty cycle to a maximum value
		D14	PWMLimitHi 4	1	
		D13	PWMLimitHi 3	0	
		D12	PWMLimitHi 2	0	
		D11	PWMLimitHi 1	1	
		D10	PWMLimitHi 0	1	
		D9	PWMLimitLo 5	0	PWM Limit Low Limits the PWM duty cycle to a minimum value
		D8	PWMLimitLo 4	0	
		D7	PWMLimitLo 3	1	
		D6	PWMLimitLo 2	1	
		D5	PWMLimitLo 1	0	
		D4	PWMLimitLo 0	1	PWM Enable, Enables the PWM output
		D3	PWME n	0	
		D2	PWM PreScale 2	0	
D1	PWM PreScale 1	1			
D0 (LSB)	PWM PreScale 0	1	PWM PreScale, Sets PWM frequency and resolution		

8.3 Register 000Eh:

This register holds the sequencer control bits

Register	Access	Bit	Function	Default	Note
000Eh: Sequencer control	R/W	D15 (MSB) – D2	r	0	
		D1	Seq	1	Sequencer Enable
		D0 (LSB)	SL	0	Single Loop

8.4 Register 000Fh:

This register holds the threshold and hysteresis of the Cordic magnitude value (see register 0120h), at which the “Magnet Lost” flag in register 0107h is set/cleared.

Register	Access	Bit	Function	Default	Note
000Fh:	R/W	D15 (MSB)	r	0	reserved
		D14	r	0	
		D13	r	0	
		D12	r	0	
		D11	r	0	
		H2	Hyst	0	Hysteresis for “magnet lost”
		H1	Hyst	0	
		H0	Hyst	1	
		V7	MgnLostLmt	0	Magnet lost threshold value compared to register 0121h
		V6	MgnLostLmt	0	
		V5	MgnLostLmt	0	
		V4	MgnLostLmt	0	
		V3	MgnLostLmt	0	
		V2	MgnLostLmt	0	
		V1	MgnLostLmt	1	
V0 (LSB)	MgnLostLmt	1			

V7...V0: The minimum allowed Magnitude of Cordic can be selected. The binary number, represented by V7...V0 must be multiplied with 64 to calculate the minimum allowed Magnitude of Cordic.

Example:

Select V0 and V1.

binary								decimal
V7	V6	V5	V4	V3	V2	V1	V0	
0	0	0	0	0	0	1	1	3

The corresponding dual number to 0000011 is 3 this number multiplied with 64 is the minimum allowed Magnitude of Cordic.

$64 * 3 = 192 = \text{Threshold limit}$

If the magnitude of cordic turns under 192 the MagLost bit in register 0107h will turn from 0 to 1.

H2...H0: The Hysteresis around the minimum allowed Magnitude of Cordic can be selected.

The Hysteresis *Hystd* is calculated by the Formula

Hyst ...Hysteresis value in Register 000Fh

Hystd ...decimal Hysteresis value around the minimum allowed Magnitude of Cordic

MgnLostLmt ...the Threshold limit as calculated in the example above.

$$Hystd = MgnLostLmt \cdot \frac{1}{2^{Hyst}}$$

Example:

Select H0

binary			decimal
H2	H1	H0	
0	0	1	1

$$Hystd = MgnLostLmt \cdot \frac{1}{2^{Hyst}} = 192 \cdot \frac{1}{2^1} = 96$$

Now the MagLost bit in register 0107h will turn from 0 to 1 at a Magnitude of Cordic value lower than 192. After the MagLost bit is 0 it turns back to 1 at a value higher than 288, because $192 + 96 = 288$.

8.5 Register 0030h:

E²PROM address

Register	Access	Bit	Function	Note
0030h: E ² PROM address	R/W	D15 (MSB)	A15	To read/write E ² PROM contents, the selected E ² PROM address must be specified in this register. The corresponding data is available in register 0031h. For write operations, status bit ED in register 0107h which indicates the completion of a write operation must be verified before starting a new write cycle. Writing 16 bits of data requires ~20ms
		D14	A14	
		D13	A13	
		D12	A12	
		D11	A11	
		D10	A10	
		D9	A9	
		D8	A8	
		D7	A7	
		D6	A6	
		D5	A5	
		D4	A4	
		D3	A3	
		D2	A2	
		D1	A1	
		D0 (LSB)	A0	

8.6 Register 0031h:

E²PROM data

Register	Access	Bit	Function	Note
0031h: E ² PROM data	R/W	D15 (MSB)	D15	This register holds the E ² PROM contents of the address selected in register 0030h
		D14	D14	
		D13	D13	
		D12	D12	
		D11	D11	
		D10	D10	
		D9	D9	
		D8	D8	
		D7	D7	
		D6	D6	
		D5	D5	
		D4	D4	
		D3	D3	
		D2	D2	
		D1	D1	
		D0 (LSB)	D0	

8.7 Register 0107h:

Status register; this register holds various status flags

Register	Access	Bit	Function	Note
0107h: Status	R	D15 (MSB)	RDY	Indicates completion of a new measurement; same function as the "Ready" output pin. 0 = calculation is in progress or chip not ready 1 = measurement completed, new measurement data is stored in register 0110h-0114h and 0120h-0122h
		D14	MagLost	1 = Magnetic field values are too low for position measurement; the threshold level can be selected at Register 000Fh Bit D7...D0
		D13	CorrOvfl	Ambiguous angle correction overflow
		D12	NormOvfl	Normalizing scale overflow
		D11	SensOvfl	Overflow during sensitivity correction over temperature
		D10	RngWarn	ADC overflow
		D9	HistWarn	Histogram failure during ADC operation
		D8	CalcError	Or wired combination of RngWarn, HistWarn, NormOvfl, SensOvfl
		D7	D7	-reserved-
		D6	D6	-reserved-
		D5	D5	-reserved-
		D4	D4	-reserved-
		D3	D3	-reserved-
		D2	D2	-reserved-
		D1	MagDir	Detected or chosen orientation of Magnet
		D0 (LSB)	ED	E ² PROM write cycle: 0 = E ² PROM write cycle in progress 1 = E ² PROM write cycle completed

8.8 Register 0108h:

Cycle Redundancy Check (CRC):

Register	Access	Bit	Function	Note
0108h: CRC	R	D15 (MSB)	CRC15	Checksum Reading Check
		D14	CRC14	
		D13	CRC13	
		D12	CRC12	
		D11	CRC11	
		D10	CRC10	
		D9	CRC9	
		D8	CRC8	
		D7	CRC7	
		D6	CRC6	
		D5	CRC5	
		D4	CRC4	
		D3	CRC3	
		D2	CRC2	
		D1	CRC1	
		D0 (LSB)	CRC0	

8.9 Register 0110h:

On-chip temperature sensor:

Register	Access	Bit	Function	Note
0110h: Temperature	R	D15 (MSB)	T15	on-chip temperature sensor Temperature[°C] = (Register110h / 200) + 25
		D14	T14	
		D13	T13	
		D12	T12	
		D11	T11	
		D10	T10	
		D9	T9	
		D8	T8	
		D7	T7	
		D6	T6	
		D5	T5	
		D4	T4	
		D3	T3	
		D2	T2	
		D1	T1	
		D0 (LSB)	T0	

8.10 Register 0111h:

Magnetic field of Pixel cell 1; Z field sensor cell

Register	Access	Bit	Function	Note
0111h: Magnetic field value	R	D15 (MSB)	Bz1	Magnetic field Bz of Pixel-cell 1
		D14		
		D13		
		D12		
		D11		
		D10		
		D9		
		D8		
		D7		
		D6		
		D5		
		D4		
		D3		
		D2		
		D1		
		D0 (LSB)		

8.11 Register 0112h:

Magnetic field of Pixel cell 0; Z field sensor cell

Register	Access	Bit	Function	Note
0112h: Magnetic field value	R	D15 (MSB)	Bz0	Magnetic field Bz of Pixel-cell 0
		D14		
		D13		
		D12		
		D11		
		D10		
		D9		
		D8		
		D7		
		D6		
		D5		
		D4		
		D3		
		D2		
		D1		
		D0 (LSB)		

8.12 Register 0113h:

Magnetic field of Pixel cell 1; X field sensor cell

Register	Access	Bit	Function	Note
0113h: Magnetic field value	R	D15 (MSB)	Bx1	Magnetic field Bx of Pixel-cell 1
		D14		
		D13		
		D12		
		D11		
		D10		
		D9		
		D8		
		D7		
		D6		
		D5		
		D4		
		D3		
		D2		
		D1		
		D0 (LSB)		

8.13 Register 0114h:

Magnetic field of Pixel cell 0; X field sensor cell

Register	Access	Bit	Function	Note
0114h: Magnetic field value	R	D15 (MSB)	Bx0	Magnetic field Bx of Pixel-cell 0
		D14		
		D13		
		D12		
		D11		
		D10		
		D9		
		D8		
		D7		
		D6		
		D5		
		D4		
		D3		
		D2		
		D1		
		D0 (LSB)		

8.14 Register 0120h:

Cordic magnitude value; this is representing the strength of the magnetic field, as calculated by the Cordic. These values may for example be used to check the magnet for out-of-range conditions, or to issue a “weak magnetic field” warning when the value gets below a certain threshold

Register	Access	Bit	Function	Note
0120h: Magnitude	R	D15 (MSB)	Mag	Magnitude value of cordic Calculation in absolute mode (DiffMd = 0) $0120h = 0.82338 * \sqrt{0111h^2 + 0113h^2}$ Calculation in differential mode (DiffMd = 1) $0120h = 0.82338 * \sqrt{(0112h - 0111h)^2 + (0114h - 0113h)^2}$
		D14		
		D13		
		D12		
		D11		
		D10		
		D9		
		D8		
		D7		
		D6		
		D5		
		D4		
		D3		
		D2		
		D1		
		D0 (LSB)		

8.15 Register 0121h:

Cordic angle value; this is representing the (non-linearized) angle or direction of the magnetic field, as calculated by the Cordic.

Register	Access	Bit	Function	Note
0121h: Angle	R	D15 (MSB)	Ang	Ang [°]...angle value of cordic [°] 0121h ... angle value of cordic [LSB] MgRangExt = 0: $\text{Ang [°]} = \frac{360}{65536} * 0121h$ MgRangExt = 1: $\text{Ang [°]} = \frac{576}{65536} * 0121h$
		D14		
		D13		
		D12		
		D11		
		D10		
		D9		
		D8		
		D7		
		D6		
		D5		
		D4		
		D3		
		D2		
		D1		
		D0 (LSB)		

8.16 Register 0122h:

This register holds the final, calculated and linearized position information

Register	Access	Bit	Function	Note
0122h: Position	R	D15 (MSB)	LinAng	<p>This register holds the linearized 16-bit position information.</p> <p>LinAng [?]...linearized 16-bit position information [?] 0121h ... linearized 16-bit position information [LSB]</p> <p>MgRangExt = 0: $\text{LinAng [?]} = \frac{360}{65536} * 0122h$ </p> <p>MgRangExt = 1: $\text{LinAng [?]} = \frac{576}{65536} * 0122h$ </p>
		D14		
		D13		
		D12		
		D11		
		D10		
		D9		
		D8		
		D7		
		D6		
		D5		
		D4		
		D3		
		D2		
		D1		
		D0 (LSB)		

8.17 EEPROM Linearization Table 005Fh to 007Fh

The data output of the Cordic can be linearized using the 33 points stored in the EEPROM

Register	Content	Note
005Fh	Angle linearization table, value 16	Applied to Cordic Output
0060h	Angle linearization table, value 0	
0061h	Angle linearization table, value 1	
...	...	
006Fh	Angle linearization table, value 15	
0070h	Angle linearization table, value -16	
0071h	Angle linearization table, value -15	
...	...	
007Eh	Angle linearization table, value -2	
007Fh	Angle linearization table, value -1	

9 Magnet features

9.1 Magnet Range Extension

If the magnet is far away from the sensor, the field vectors in the sensor position can generate false angle information. By exploiting the magnetic field behaviour it is still possible to calculate correct position information. As absolute field values are used during this calculation external disturbance fields must not exceed a maximum of approximately ten times the terrestrial magnetic field. The position range extending calculation method can be disabled if large disturbance fields occur during operation.

MgRangExt = 0: angles between -180° and $+180^\circ$ can be measured

MgRangExt = 1: angles between -288° and $+288^\circ$ can be measured

Register	Access	Bit	Function	Note
000Bh: Sequencer control	R/W	D11	MgRangExt	"Magnet Range Extension" Enable the algorithm for an extended position range.
		D10	CoordSel	"Coordinate System Selection" 1 = The sign of the LinAng (Register 0122h) gets changed if MagDir (Register 000Bh) = 1 0 = LinAng (Register 0122h) gets not changed

Notes:

- 2) Pins LOCK_N and SCE are test pins for factory testing. They must be connected to VSS in normal operation to prevent accidental enabling of a test mode
- 3) Output READY is set high when a measurement cycle is completed and the results in the output registers are valid. It is cleared by reading data from address 0100h or 0122h
- 4) CLK allows monitoring of the internal clock or applying an external clock.
- 5) Output MISO is only activated when CS_N is low. It is in high impedance state otherwise, this allows parallel operation of multiple ICs.
- 6) CS_N is active low and activates data transmission. If only a single device is used, CS_N may remain low for several commands, for example while reading the output registers.

10 PWM data transmission

In addition to the SPI interface, the AS5410 offers a PWM output that provides data transmission of the linearized output data over a single wire. The base frequency of the PWM is the system clock frequency, so one PWM digit always corresponds to approx. 125ns. The PWM resolution is set by 3 bits (PWMPreScale) which shift the 16 bit wide angle value by 0 to 7 digits.

The duty cycle of the PWM signal lies between 0...100%. In case of an error, the duty cycle is 0%.

If Register 0122h value increases the duty cycle decreases. If Register 0122h value decreases the duty cycle increases.

Register	Access	Bit	Function	Note
000Dh: PWM settings	R/W	D15-10	PWMLimitHi <5:0>	PWM Limit High Limits the PWM duty cycle to a maximum value
		D9-4	PWMLimitLo <5:0>	PWM Limit Low Limits the PWM duty cycle to a minimum value
		D3	PWMEen	PWM Enable, Enables the PWM output
		D2-0	PWMPreScale <2:0>	PWM PreScale, Sets PWM frequency and resolution

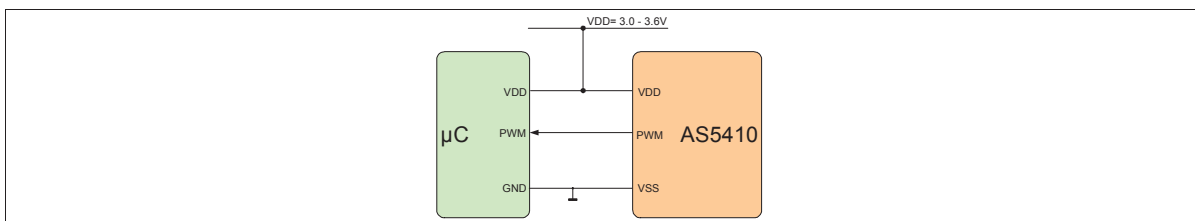

Figure 9: Single pin data transmission connection diagram

PWM Duty Cycle [%]	Register 122h (Linear Angle) [LSB]
0	32767
50	0
100	-32768

Between 0%...100% the duty cycle is linear to the Linear Angle.

PWM Enable: Must be set high to enable the PWM mode.

PWMPreScale0...PWMPreScale3: The PWM resolution is set by those 3 Bits.

PWMPreScale0...PWMPreScale3	Resolution (bit)	PWM (kHz)
000	16	0.122
001	15	0.244
010	14	0.488
011	13	0.977
100	12	1.953
101	11	3.906
110	10	7.813
111	9	15.63

PWMLimitHi5...PWMLimitHi0: Limits the PWM duty cycle.

duty cycle	PWMLimitHi0...PWMLimitHi5
minimum 50%	000000
minimum 0%	111111

Between 0%...50% the duty cycle limit is linear to the binary values selected by PWMLimitHi5...PWMLimitHi0. The limits are clamping limits (by selecting limits the resolution decreases).

PWMLimitLo5...PWMLimitLo0: Limits the PWM duty cycle.

duty cycle	PWMLimitLo0...PWMLimitLo5
maximum 50%	111111
maximum 100%	000000

Between 50%...100% the duty cycle limit is linear to the binary values selected by PWMLimitLo5...PWMLimitLo0. The limits are clamping limits (by selecting limits the resolution decreases).

Example Table:

clamping range	0% – 100% PWM duty cycle	10% – 90% PWM duty cycle	50% – 50% PWM duty cycle
PWMLimitHi5	1	1	0
PWMLimitHi4	1	1	0
PWMLimitHi3	1	0	0
PWMLimitHi2	1	0	0
PWMLimitHi1	1	1	0
PWMLimitHi0	1	0	0
PWMLimitLo5	0	0	1
PWMLimitLo4	0	0	1
PWMLimitLo3	0	1	1
PWMLimitLo2	0	1	1
PWMLimitLo1	0	0	1
PWMLimitLo0	0	1	1

Package Drawings and Markings

10.1 Pixel cell placement

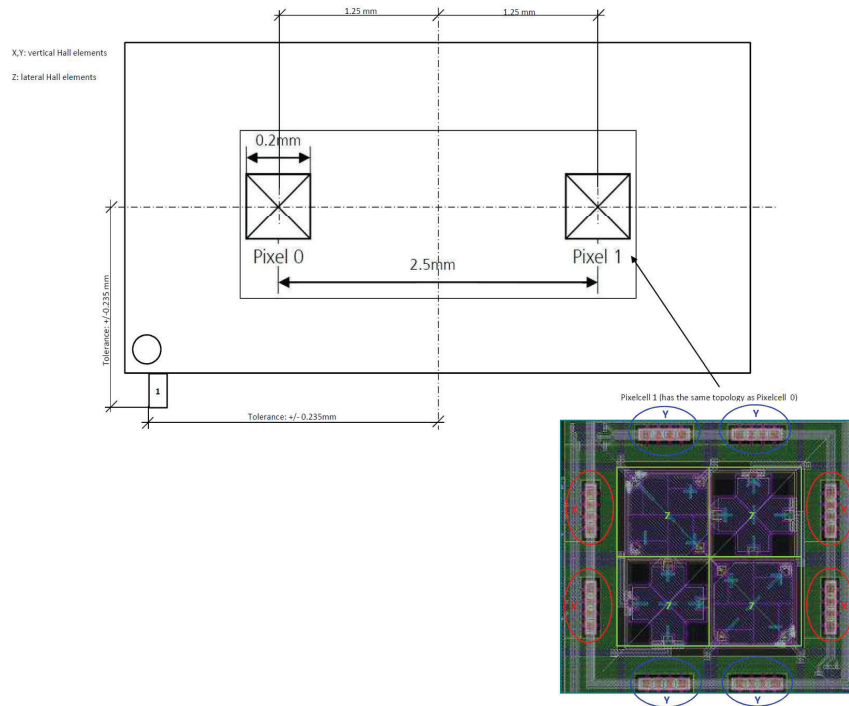

10.2 14-Lead Thin Shrink Small Outline Package TSSOP-14

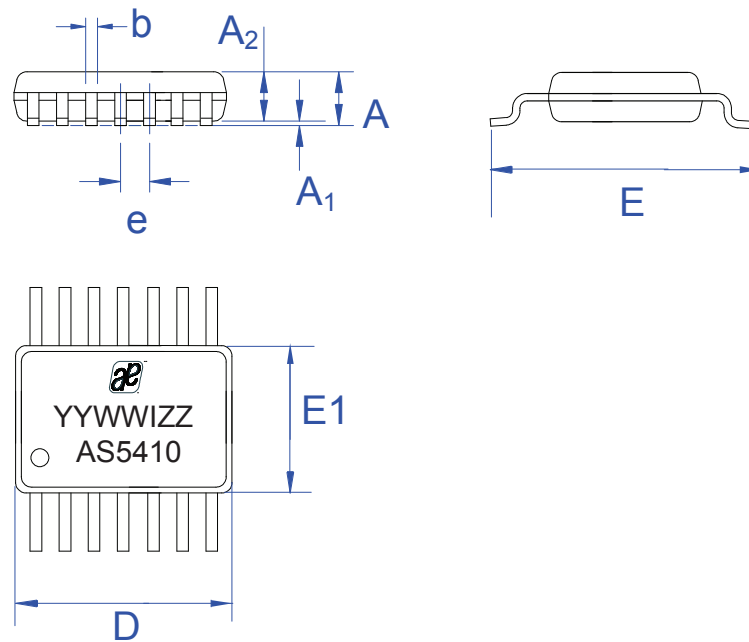

Figure 11: TSSOP-14 Package Dimensions and Marking

Dimensions						
Symbol	mm			inch		
	Min	Typ	Max	Min	Typ	Max
A			1.2			.047
A1	0.05	0.10	0.15	.002	.004	.006
A2	0.8	1	1.05	0.031	0.039	0.041
b	0.19		0.30	0.007		0.012
D	4.9	5	5.1	0.193	0.197	0.201
E	6.2	6.4	6.6	0.244	0.252	0.260
E1	4.3	4.4	4.48	0.169	0.173	0.176
e	0.65			.0256		

Table 6: Package Dimensions

Marking: YYWWIZZ

YY: Last Digit of Manufacturing Year
 WW: Manufacturing Week
 I: Plant Identifier
 ZZ: Traceability Code

Thermal Resistance $R_{th(j-a)}$:
 89 K/W in still air, soldered on PCB

IC's marked with a white dot or the letters "ES" denote Engineering Samples

Ordering Information

The devices are available as standard products, shown in Table 7.

Model	Description	Delivery Form	Package
AS5410TSU	Three-Dimensional Hall Encoder	Tubes	TSSOP 14
AS5410TST		Tape & Reel	TSSOP 14

Table 7: Ordering Information

10.3 Revision History

Revision	Description	Change date
1.0	Released preliminary version	May.30.2011
1.1	Additional information added	Jun.05.2011
1.2	Additional information added	Jan.12.2012
1.5	Chapter 10: example table corrected	Apr.06.2012

Table 8: revision history

11 Copyrights

Copyright © 2011, austriamicrosystems AG, Schloss Premstaetten, 8141 Unterpremstaetten, Austria – Europe. Trademarks Registered ®. All rights reserved. The material herein may not be reproduced, adapted, merged, translated, stored, or used without the prior written consent of the copyright owner. All products and companies mentioned are trademarks or registered trademarks of their respective companies.

12 Disclaimer

Devices sold by austriamicrosystems AG are covered by the warranty and patent indemnification provisions appearing in its Term of Sale. austriamicrosystems AG makes no warranty, express, statutory, implied, or by description regarding the information set forth herein or regarding the freedom of the described devices from patent infringement. austriamicrosystems AG reserves the right to change specifications and prices at any time and without notice. Therefore, prior to designing this product into a system, it is necessary to check with austriamicrosystems AG for current information. This product is intended for use in normal commercial applications. Applications requiring extended temperature range, unusual environmental requirements, or high reliability applications, such as military, medical life-support or lifesustaining equipment are specifically not recommended without additional processing by austriamicrosystems AG for each application.

The information furnished here by austriamicrosystems AG is believed to be correct and accurate. However, austriamicrosystems AG shall not be liable to recipient or any third party for any damages, including but not limited to personal injury, property damage, loss of profits, loss of use, interruption of business or indirect, special, incidental or consequential damages, of any kind, in connection with or arising out of the furnishing, performance or use of the technical data herein. No obligation or liability to recipient or any third party shall arise or flow out of austriamicrosystems AG rendering of technical or other services.



Contact Information

Headquarters

austriamicrosystems AG
A-8141 Schloss Premstaetten, Austria
Tel: +43 (0) 3136 500 0
Fax: +43 (0) 3136 525 01

For Sales Offices, Distributors and Representatives, please visit:

<http://www.austriamicrosystems.com/contact>