

100mA POSITIVE VOLTAGE REGULATOR**AS78LXX****General Description**

The AS78LXX series are three terminal positive regulators designed for a wide variety of applications including local, on-card regulation.

This series of regulators are complete with internal current limiting, thermal shutdown protection, and safe-area compensation which make them virtually immune from output overload. If adequate heat sinking are provided, these regulators can deliver output currents up to 100mA.

The AS78LXX series are available in TO-92 (bulk or ammo packing), SOT-89 and SOIC-8 packages.

Features

- Output Current up to 100mA
- Fixed Output Voltages of 5V, 12V, 15V, 18V and 24V
- Output Voltage Accuracy of $\pm 5\%$ over the Full Temperature Range
- Internal Short Circuit Current Limiting
- Internal Thermal Overload Protection
- No External Components
- Output Transistor Safe-area Protection

Applications

- Consumer Electronics
- Microprocessor Power Supply
- Mother Board

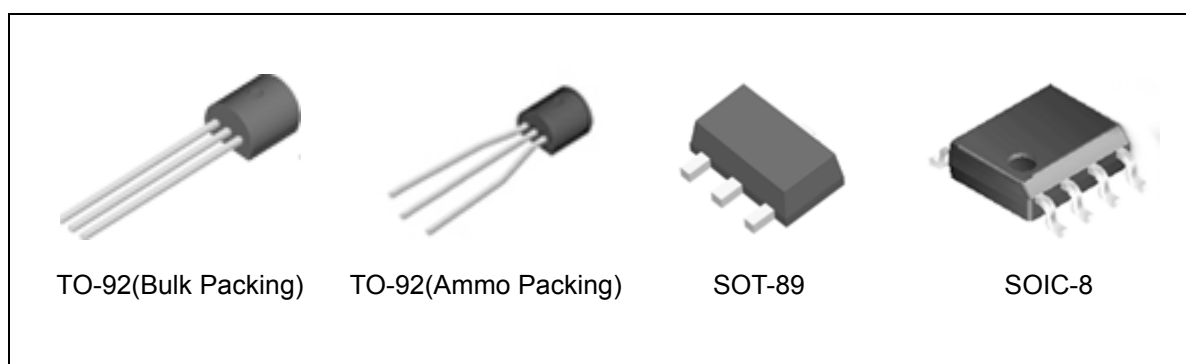

Figure 1. Package Types of AS78LXX

Pin Configuration

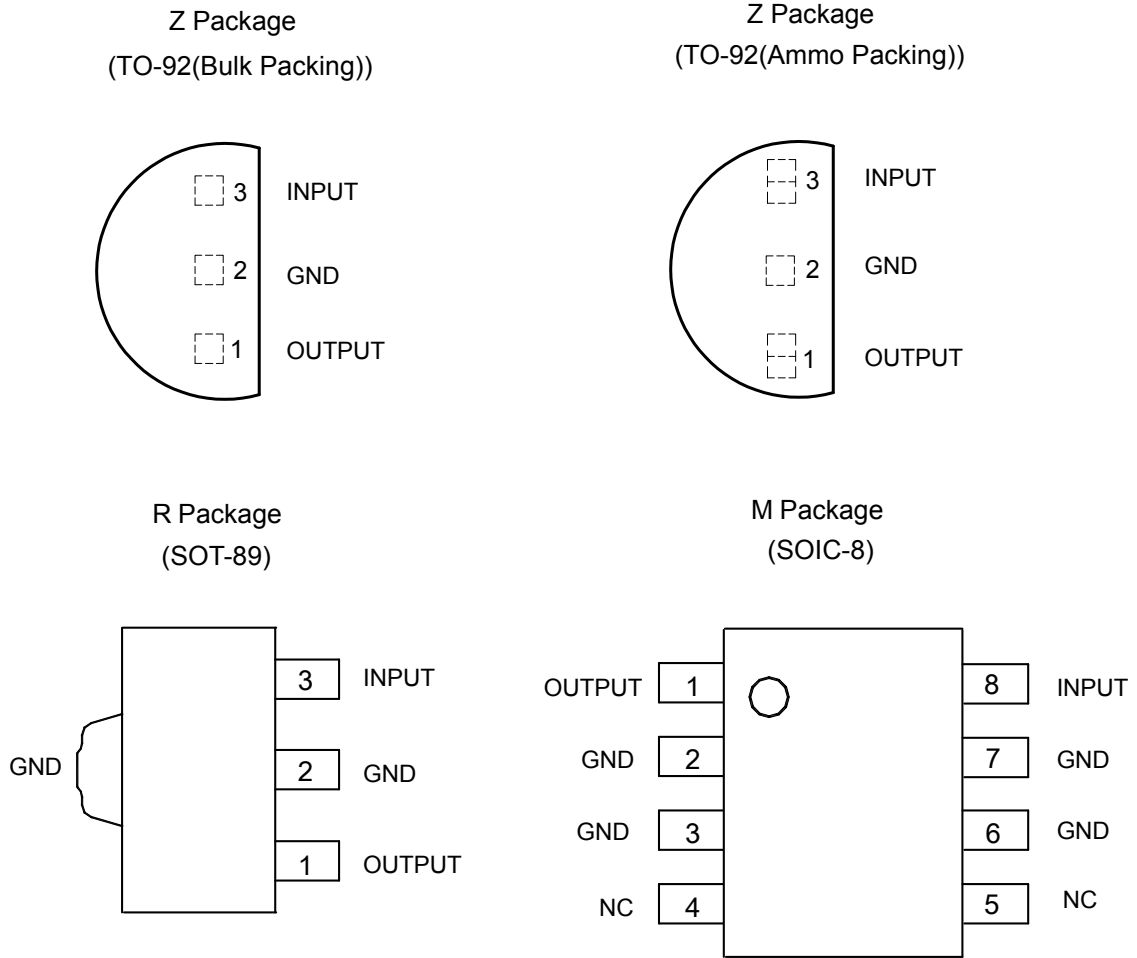
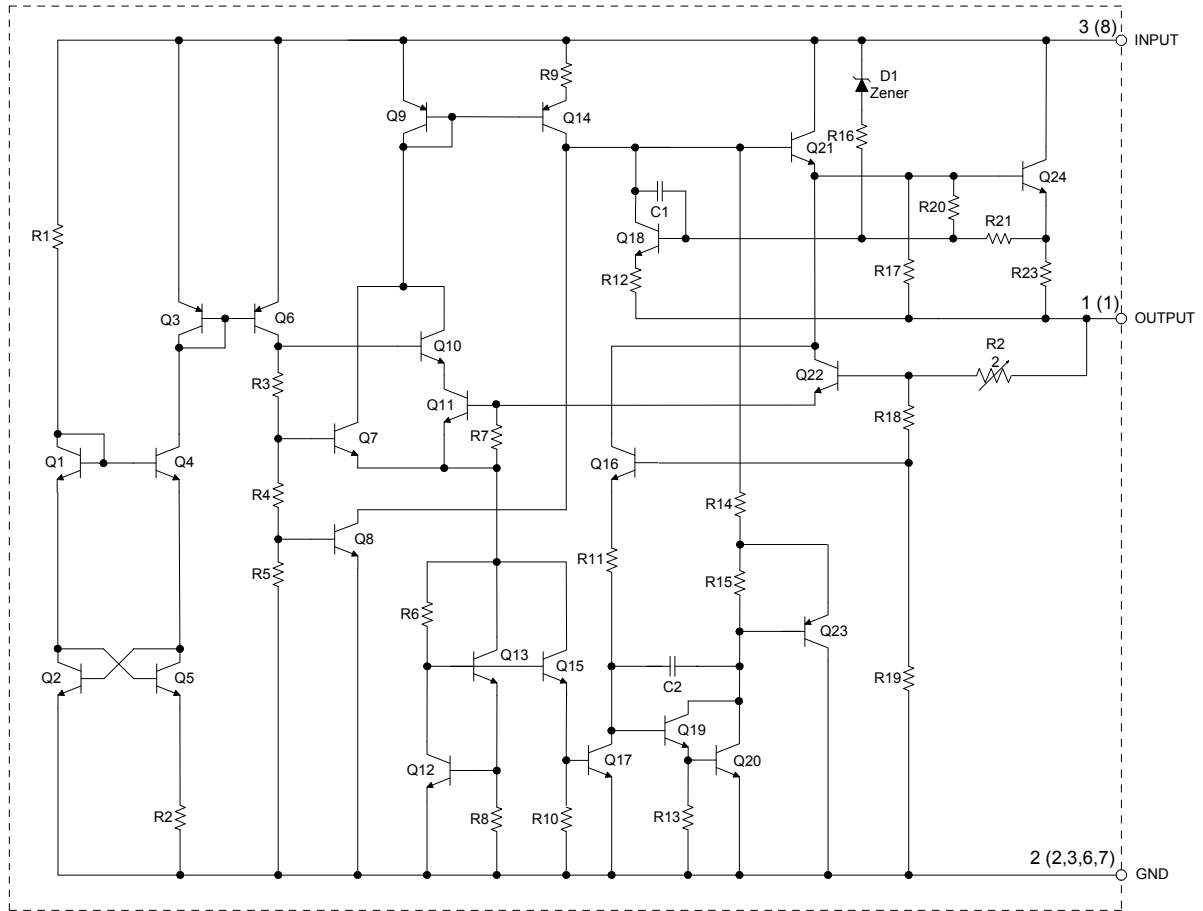

Figure 2. Pin Configuration of AS78LXX (Top View)

100mA POSITIVE VOLTAGE REGULATOR

AS78LXX

Functional Block Diagram



A (B)

A for 3-pin B for 8-pin

Figure 3. Functional Block Diagram of AS78LXX



100mA POSITIVE VOLTAGE REGULATOR

AS78LXX

Ordering Information

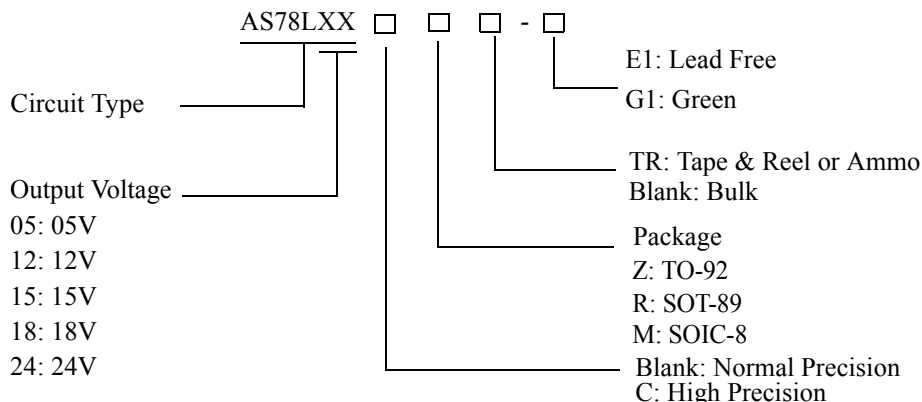

Package	Temperature Range	Part Number		Marking ID		Packing Type
		Lead Free	Green	Lead Free	Green	
TO-92	-40 to 125°C	AS78L05Z-E1	AS78L05Z-G1	AS78L05Z-E1	AS78L05Z-G1	Bulk
		AS78L05ZTR-E1	AS78L05ZTR-G1	AS78L05Z-E1	AS78L05Z-G1	Ammo
		AS78L05CZTR-E1	AS78L05CZTR-G1	AS78L05Z-E1	AS78L05Z-G1	Ammo
		AS78L12Z-E1	AS78L12Z-G1	AS78L12Z-E1	AS78L12Z-G1	Bulk
		AS78L12ZTR-E1	AS78L12ZTR-G1	AS78L12Z-E1	AS78L12Z-G1	Ammo
		AS78L15Z-E1	AS78L15Z-G1	AS78L15Z-E1	AS78L15Z-G1	Bulk
		AS78L15ZTR-E1	AS78L15ZTR-G1	AS78L15Z-E1	AS78L15Z-G1	Ammo
		AS78L18Z-E1	AS78L18Z-G1	AS78L18Z-E1	AS78L18Z-G1	Bulk
		AS78L18ZTR-E1	AS78L18ZTR-G1	AS78L18Z-E1	AS78L18Z-G1	Ammo
		AS78L24Z-E1	AS78L24Z-G1	AS78L24Z-E1	AS78L24Z-G1	Bulk
		AS78L24ZTR-E1	AS78L24ZTR-G1	AS78L24Z-E1	AS78L24Z-G1	Ammo
SOT-89	-40 to 125°C	AS78L05RTR-E1	AS78L05RTR-G1	E78E	G78E	Tape & Reel
		AS78L12RTR-E1	AS78L12RTR-G1	E78F	G78F	Tape & Reel
		AS78L15RTR-E1	AS78L15RTR-G1	E78G	G78G	Tape & Reel
		AS78L18RTR-E1	AS78L18RTR-G1	E78H	G78H	Tape & Reel
		AS78L24RTR-E1	AS78L24RTR-G1	E78I	G78I	Tape & Reel
SOIC-8	-40 to 125°C	AS78L05M-E1	AS78L05M-G1	AS78L05M-E1	AS78L05M-G1	Tube
		AS78L05MTR-E1	AS78L05MTR-G1	AS78L05M-E1	AS78L05M-G1	Tape & Reel
		AS78L12M-E1	AS78L12M-G1	AS78L12M-E1	AS78L12M-G1	Tube
		AS78L12MTR-E1	AS78L12MTR-G1	AS78L12M-E1	AS78L12M-G1	Tape & Reel
		AS78L15M-E1	AS78L15M-G1	AS78L15M-E1	AS78L15M-G1	Tube
		AS78L15MTR-E1	AS78L15MTR-G1	AS78L15M-E1	AS78L15M-G1	Tape & Reel
		AS78L18M-E1	AS78L18M-G1	AS78L18M-E1	AS78L18M-G1	Tube
		AS78L18MTR-E1	AS78L18MTR-G1	AS78L18M-E1	AS78L18M-G1	Tape & Reel
		AS78L24M-E1	AS78L24M-G1	AS78L24M-E1	AS78L24M-G1	Tube
AS78L24MTR-E1	AS78L24MTR-G1	AS78L24M-E1	AS78L24M-G1	Tape & Reel		

BCD Semiconductor's Pb-free products, as designated with "E1" suffix in the part number, are RoHS compliant. Products with "G1" suffix are available in green packages.

**100mA POSITIVE VOLTAGE REGULATOR****AS78LXX****Absolute Maximum Ratings (Note 1)**

Parameter	Symbol	Value		Unit
Input Voltage	V_{IN}	36		V
Operating Junction Temperature	T_J	150		°C
Lead Temperature (Soldering, 10sec)	T_{LEAD}	260		°C
Power Dissipation	P_D	750		mW
Storage Temperature Range	T_{STG}	-65 to 150		°C
Thermal Resistance	θ_{JA}	TO-92	180	°C/W
ESD (Human Body Model)	ESD	2000		V
ESD (Machine Model)	ESD	200		V

Note 1: Stresses greater than those listed under "Absolute Maximum Ratings" may cause permanent damage to the device. These are stress ratings only, and functional operation of the device at these or any other conditions beyond those indicated under "Recommended Operating Conditions" is not implied. Exposure to "Absolute Maximum Ratings" for extended periods may affect device reliability.

Recommended Operating Conditions

Parameter		Symbol	Min	Max	Unit
Input Voltage	AS78L05	V_{IN}		30	V
	AS78L12			36	
	AS78L15			36	
	AS78L18			36	
	AS78L24			36	
Operating Junction Temperature Range		T_J	-40	125	°C



100mA POSITIVE VOLTAGE REGULATOR

AS78LXX

Electrical Characteristics

AS78L05 ($V_{IN}=10V$, $I_{OUT}=40mA$, $C_{IN}=0.33\mu F$, $C_{OUT}=0.1\mu F$, $T_J=25^\circ C$, **Bold** typeface applies over $-40^\circ C \leq T_J \leq 125^\circ C$, unless otherwise specified.)

Parameter	Symbol	Conditions	Min	Typ	Max	Unit
Output Voltage	V_{OUT}		4.8	5.0	5.2	V
		$7V \leq V_{IN} \leq 20V$, $1mA \leq I_{OUT} \leq 100mA$, $P_D \leq 0.75W$	4.75		5.25	
Line Regulation	V_{RLINE}	$7V \leq V_{IN} \leq 20V$		8	150	mV
Load Regulation	V_{RLOAD}	$1mA \leq I_{OUT} \leq 100mA$		10	60	mV
Quiescent Current	I_Q			3	5.5	mA
Quiescent Current Change	ΔI_Q	$8V \leq V_{IN} \leq 20V$			1.5	mA
		$1mA \leq I_{OUT} \leq 40mA$			0.1	
Ripple Rejection	PSRR	$f=120Hz$, $8V \leq V_{IN} \leq 18V$	47	62		dB
Dropout Voltage	V_{DROP}	$I_{OUT}=40mA$		1.7		V
		$I_{OUT}=100mA$		1.8		
Output Noise Voltage	N_O	$10Hz \leq f \leq 100kHz$ (Note 2)		40		μV
Output Voltage Temperature Coefficient	$\Delta V_{OUT}/\Delta T$	$I_{OUT}=5mA$		0.42		mV/ $^\circ C$
	$(\Delta V_{OUT}/V_{OUT})/\Delta T$			84		ppm/ $^\circ C$
Thermal Resistance	θ_{JC}	TO-92		40		$^\circ C/W$
		SOT-89		28.3		
		SOIC-8		62		

Note 2: 0.01 μF minimum load capacitance is recommended to limit high frequency noise.

**100mA POSITIVE VOLTAGE REGULATOR****AS78LXX****Electrical Characteristics (Continued)**

AS78L05C ($V_{IN}=10V$, $I_{OUT}=40mA$, $C_{IN}=0.33\mu F$, $C_{OUT}=0.1\mu F$, $T_J=25^\circ C$, **Bold** typeface applies over $-40^\circ C \leq T_J \leq 125^\circ C$, unless otherwise specified.)

Parameter	Symbol	Conditions	Min	Typ	Max	Unit
Output Voltage	V_{OUT}		5.0		5.1	V
Line Regulation	V_{RLINE}	$7V \leq V_{IN} \leq 20V$		8	150	mV
Load Regulation	V_{RLOAD}	$1mA \leq I_{OUT} \leq 100mA$		10	60	mV
Quiescent Current	I_Q			3	5.5	mA
Quiescent Current Change	ΔI_Q	$8V \leq V_{IN} \leq 20V$			1.5	mA
		$1mA \leq I_{OUT} \leq 40mA$			0.1	
Ripple Rejection	PSRR	$f=120Hz$, $8V \leq V_{IN} \leq 18V$	47	62		dB
Dropout Voltage	V_{DROP}	$I_{OUT}=40mA$		1.7		V
		$I_{OUT}=100mA$		1.8		
Output Noise Voltage	N_O	$10Hz \leq f \leq 100kHz$ (Note 2)		40		μV
Output Voltage Temperature Coefficient	$\Delta V_{OUT}/\Delta T$	$I_{OUT}=5mA$		0.42		$mV/^\circ C$
	$(\Delta V_{OUT}/V_{OUT})/\Delta T$			84		ppm/ $^\circ C$
Thermal Resistance	θ_{JC}	TO-92		40		$^\circ C/W$
		SOT-89		28.3		
		SOIC-8		62		

Note 2: 0.01 μF minimum load capacitance is recommended to limit high frequency noise.



100mA POSITIVE VOLTAGE REGULATOR

AS78LXX

Electrical Characteristics (Continued)

AS78L12 ($V_{IN}=19V$, $I_{OUT}=40mA$, $C_{IN}=0.33\mu F$, $C_{OUT}=0.1\mu F$, $T_J=25^\circ C$, **Bold** typeface applies over $-40^\circ C \leq T_J \leq 125^\circ C$, unless otherwise specified.)

Parameter	Symbol	Conditions	Min	Typ	Max	Unit
Output Voltage	V_{OUT}		11.5	12.0	12.5	V
		$14.5V \leq V_{IN} \leq 27V$, $1mA \leq I_{OUT} \leq 100mA$, $P_D \leq 0.75W$	11.4		12.6	
Line Regulation	V_{RLINE}	$14.5V \leq V_{IN} \leq 27V$		20	250	mV
Load Regulation	V_{RLOAD}	$1mA \leq I_{OUT} \leq 100mA$		20	100	mV
Quiescent Current	I_Q			3	6	mA
Quiescent Current Change	ΔI_Q	$16V \leq V_{IN} \leq 27V$			1.5	mA
		$1mA \leq I_{OUT} \leq 40mA$			0.1	
Ripple Rejection	PSRR	$f=120Hz$, $15V \leq V_{IN} \leq 25V$	37	42		dB
Dropout Voltage	V_{DROP}	$I_{OUT}=40mA$		1.7		V
		$I_{OUT}=100mA$		1.8		
Output Noise Voltage	N_O	$10Hz \leq f \leq 100kHz$ (Note 2)		80		μV
Output Voltage Temperature Coefficient	$\Delta V_{OUT}/\Delta T$	$I_{OUT}=5mA$		1		mV/ $^\circ C$
	$(\Delta V_{OUT}/V_{OUT})/\Delta T$			84		ppm/ $^\circ C$
Thermal Resistance	θ_{JC}	TO-92		40		$^\circ C/W$
		SOT-89		28.3		
		SOIC-8		62		

Note 2: 0.01 μF minimum load capacitance is recommended to limit high frequency noise.



100mA POSITIVE VOLTAGE REGULATOR

AS78LXX

Electrical Characteristics (Continued)

AS78L15 ($V_{IN}=23V$, $I_{OUT}=40mA$, $C_{IN}=0.33\mu F$, $C_{OUT}=0.1\mu F$, $T_J=25^\circ C$, **Bold** typeface applies over $-40^\circ C \leq T_J \leq 125^\circ C$, unless otherwise specified.)

Parameter	Symbol	Conditions	Min	Typ	Max	Unit
Output Voltage	V_{OUT}		14.4	15.0	15.6	V
		$17.5V \leq V_{IN} \leq 30V$, $1mA \leq I_{OUT} \leq 100mA$, $P_D \leq 0.75W$	14.25		15.75	
Line Regulation	V_{RLINE}	$17.5V \leq V_{IN} \leq 30V$		25	250	mV
Load Regulation	V_{RLOAD}	$1mA \leq I_{OUT} \leq 100mA$		25	150	mV
Quiescent Current	I_Q			3	6	mA
Quiescent Current Change	ΔI_Q	$20V \leq V_{IN} \leq 30V$			1.5	mA
		$1mA \leq I_{OUT} \leq 40mA$			0.1	
Ripple Rejection	PSRR	$f=120Hz$, $18.5V \leq V_{IN} \leq 28.5V$	34	39		dB
Dropout Voltage	V_{DROP}	$I_{OUT}=40mA$		1.7		V
		$I_{OUT}=100mA$		1.8		
Output Noise Voltage	N_O	$10Hz \leq f \leq 100kHz$ (Note 2)		90		μV
Output Voltage Temperature Coefficient	$\Delta V_{OUT}/\Delta T$	$I_{OUT}=5mA$		1.25		$mV/^\circ C$
	$(\Delta V_{OUT}/V_{OUT})/\Delta T$			84		ppm/ $^\circ C$
Thermal Resistance	θ_{JC}	TO-92		40		$^\circ C/W$
		SOT-89		28.3		
		SOIC-8		62		

Note 2: 0.01 μF minimum load capacitance is recommended to limit high frequency noise.



100mA POSITIVE VOLTAGE REGULATOR

AS78LXX

Electrical Characteristics (Continued)

AS78L18 ($V_{IN}=27V$, $I_{OUT}=40mA$, $C_{IN}=0.33\mu F$, $C_{OUT}=0.1\mu F$, $T_J=25^\circ C$, **Bold** typeface applies over $-40^\circ C \leq T_J \leq 125^\circ C$, unless otherwise specified.)

Parameter	Symbol	Conditions	Min	Typ	Max	Unit
Output Voltage	V_{OUT}		17.3	18.0	18.7	V
		$22V \leq V_{IN} \leq 33V$, $1mA \leq I_{OUT} \leq 100mA$, $P_D \leq 0.75W$	17.1		18.9	
Line Regulation	V_{RLINE}	$22V \leq V_{IN} \leq 33V$		30	300	mV
Load Regulation	V_{RLOAD}	$1mA \leq I_{OUT} \leq 100mA$		30	170	mV
Quiescent Current	I_Q			3	6	mA
Quiescent Current Change	ΔI_Q	$23V \leq V_{IN} \leq 33V$			1.5	mA
		$1mA \leq I_{OUT} \leq 40mA$			0.1	
Ripple Rejection	PSRR	$f=120Hz$, $23V \leq V_{IN} \leq 33V$	33	38		dB
Dropout Voltage	V_{DROP}	$I_{OUT}=40mA$		1.7		V
		$I_{OUT}=100mA$		1.8		
Output Noise Voltage	N_O	$10Hz \leq f \leq 100kHz$ (Note 2)		150		μV
Output Voltage Temperature Coefficient	$\Delta V_{OUT}/\Delta T$	$I_{OUT}=5mA$		1.5		mV/ $^\circ C$
	$(\Delta V_{OUT}/V_{OUT})/\Delta T$			84		ppm/ $^\circ C$
Thermal Resistance	θ_{JC}	TO-92		40		$^\circ C/W$
		SOT-89		28.3		
		SOIC-8		62		

Note 2: 0.01 μF minimum load capacitance is recommended to limit high frequency noise.



100mA POSITIVE VOLTAGE REGULATOR

AS78LXX

Electrical Characteristics (Continued)

AS78L24 ($V_{IN}=33V$, $I_{OUT}=40mA$, $C_{IN}=0.33\mu F$, $C_{OUT}=0.1\mu F$, $T_J=25^\circ C$, **Bold** typeface applies over $-40^\circ C \leq T_J \leq 125^\circ C$, unless otherwise specified.)

Parameter	Symbol	Conditions	Min	Typ	Max	Unit
Output Voltage	V_{OUT}		23	24.0	25	V
		$27V \leq V_{IN} \leq 36V$, $1mA \leq I_{OUT} \leq 100mA$, $P_D \leq 0.75W$	22.8		25.2	
Line Regulation	V_{RLINE}	$27V \leq V_{IN} \leq 36V$		50	300	mV
Load Regulation	V_{RLOAD}	$1mA \leq I_{OUT} \leq 100mA$		40	200	mV
Quiescent Current	I_Q			3	6	mA
Quiescent Current Change	ΔI_Q	$28V \leq V_{IN} \leq 36V$			1.5	mA
		$1mA \leq I_{OUT} \leq 40mA$			0.1	
Ripple Rejection	PSRR	$f=120Hz$, $29V \leq V_{IN} \leq 35V$	31	37		dB
Dropout Voltage	V_{DROP}	$I_{OUT}=40mA$		1.7		V
		$I_{OUT}=100mA$		1.8		
Output Noise Voltage	N_O	$10Hz \leq f \leq 100kHz$ (Note 2)		200		μV
Output Voltage Temperature Coefficient	$\Delta V_{OUT}/\Delta T$	$I_{OUT}=5mA$		2		mV/ $^\circ C$
	$(\Delta V_{OUT}/V_{OUT})/\Delta T$			84		ppm/ $^\circ C$
Thermal Resistance	θ_{JC}	TO-92		40		$^\circ C/W$
		SOT-89		28.3		
		SOIC-8		62		

Note 2: 0.01 μF minimum load capacitance is recommended to limit high frequency noise.



100mA POSITIVE VOLTAGE REGULATOR

AS78LXX

Typical Performance Characteristics

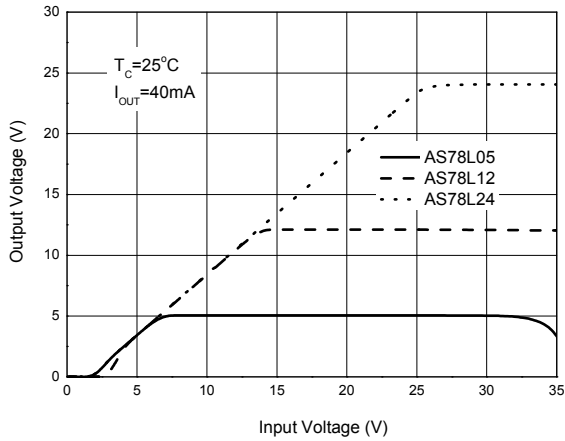

Figure 4. Output Voltage vs. Input Voltage

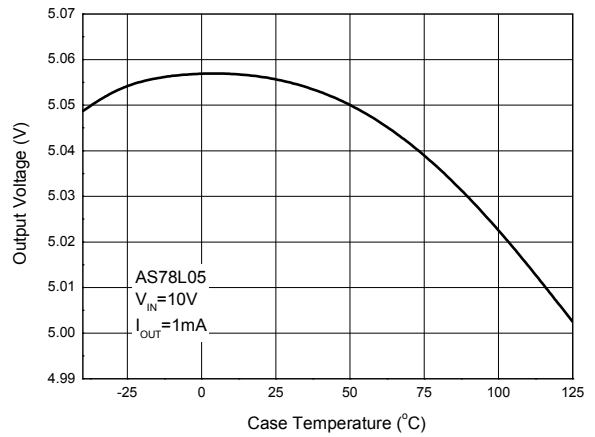

Figure 5. Output Voltage vs. Case Temperature

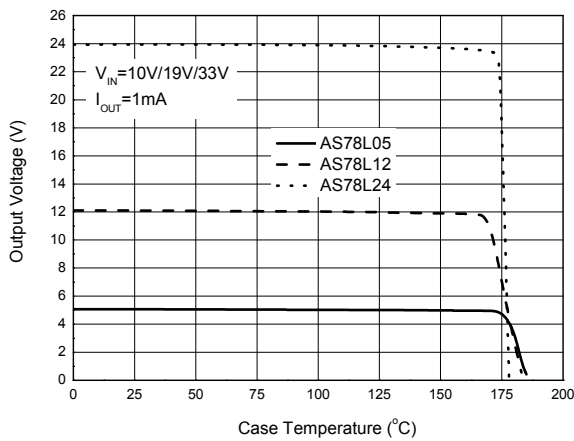

Figure 6. Over Temperature Protection

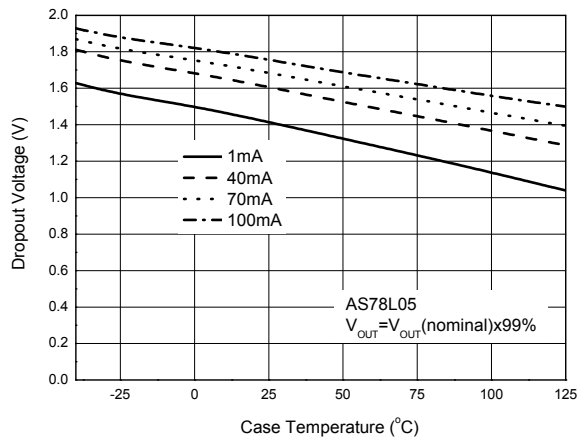

Figure 7. Dropout Voltage vs. Case Temperature



100mA POSITIVE VOLTAGE REGULATOR

AS78LXX

Typical Performance Characteristics (Continued)

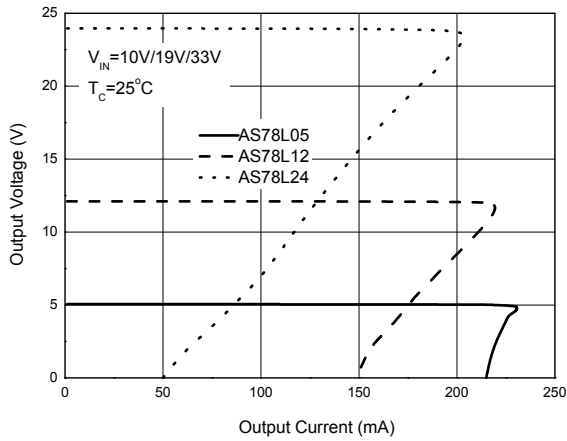

Figure 8. Output Voltage vs. Output Current

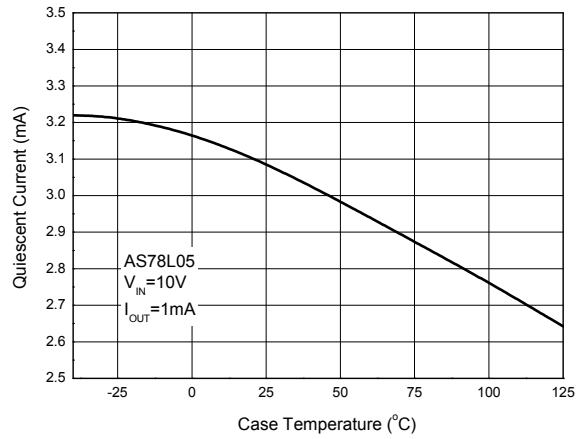

Figure 9. Quiescent Current vs. Case Temperature

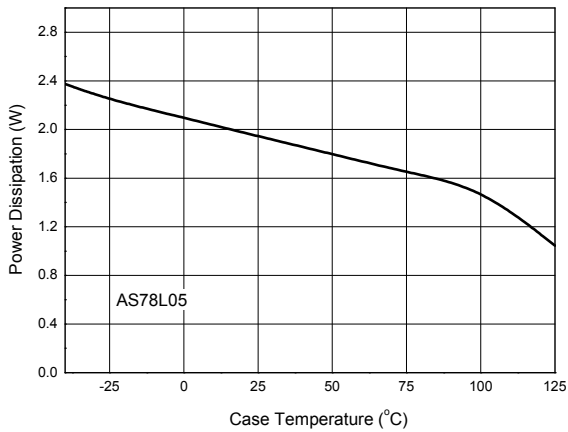

Figure 10. Power Dissipation vs. Case Temperature

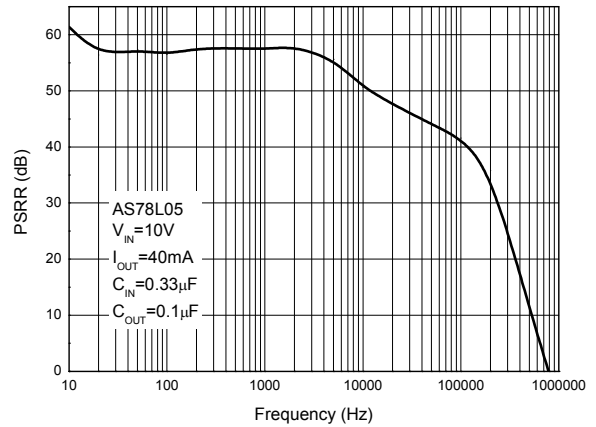

Figure 11. PSRR vs. Frequency

Typical Performance Characteristics (Continued)

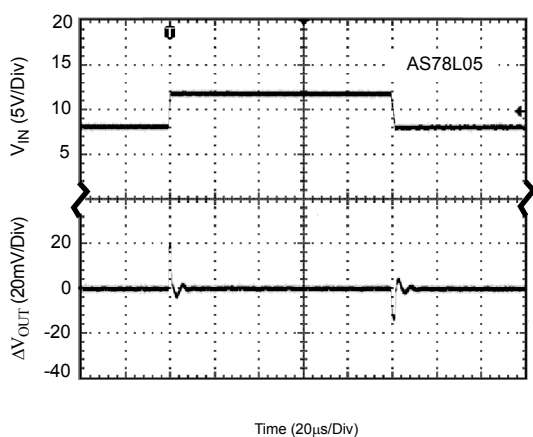

Figure 12. Line Transient

(Conditions: $I_{OUT}=40mA$, $C_{IN}=0.33\mu F$, $C_{OUT}=0.1\mu F$)

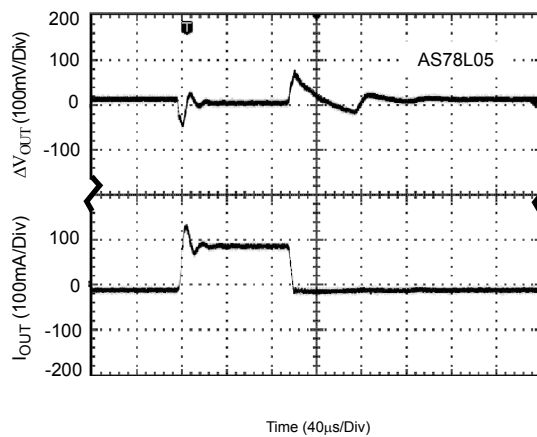

Figure 13. Load Transient

(Conditions: $V_{IN}=10V$, $C_{IN}=0.33\mu F$, $C_{OUT}=0.1\mu F$)

Typical Application

Figure 14. Typical Application of AS78LXX



100mA POSITIVE VOLTAGE REGULATOR

AS78LXX

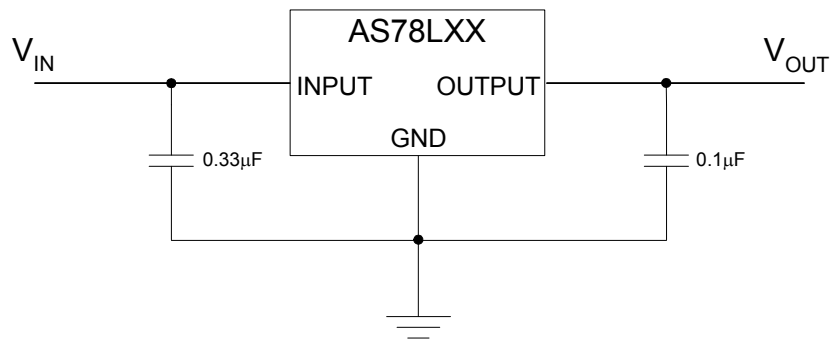
Mechanical Dimensions

TO-92(Bulk Packing)

Unit: mm(inch)

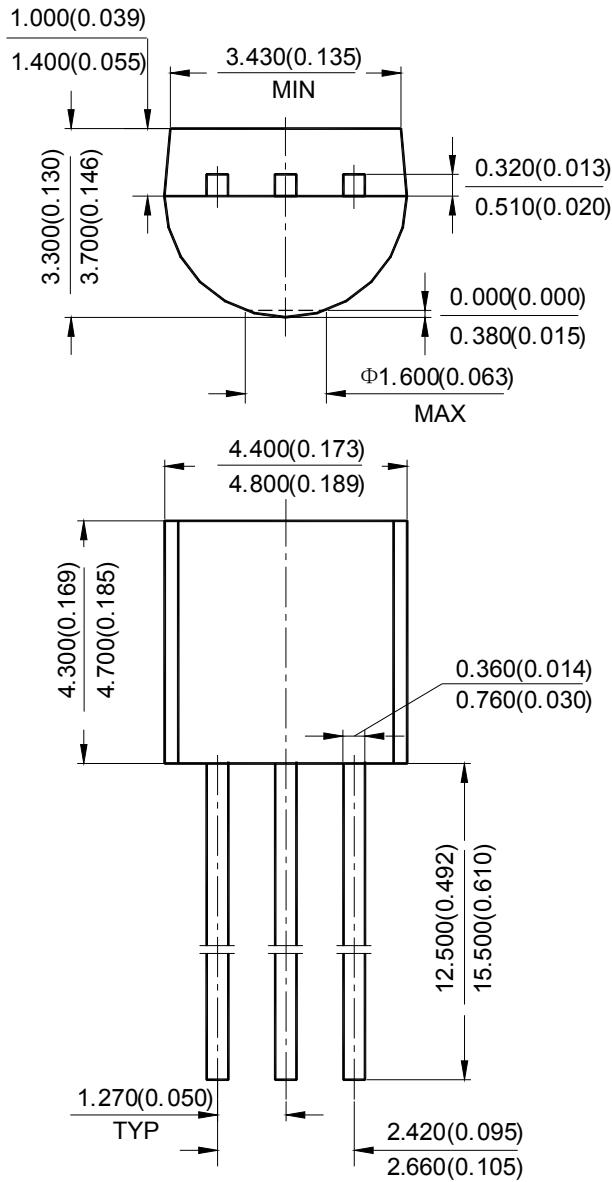



100mA POSITIVE VOLTAGE REGULATOR

AS78LXX

Mechanical Dimensions (Continued)

TO-92(Ammo Packing)

Unit: mm(inch)

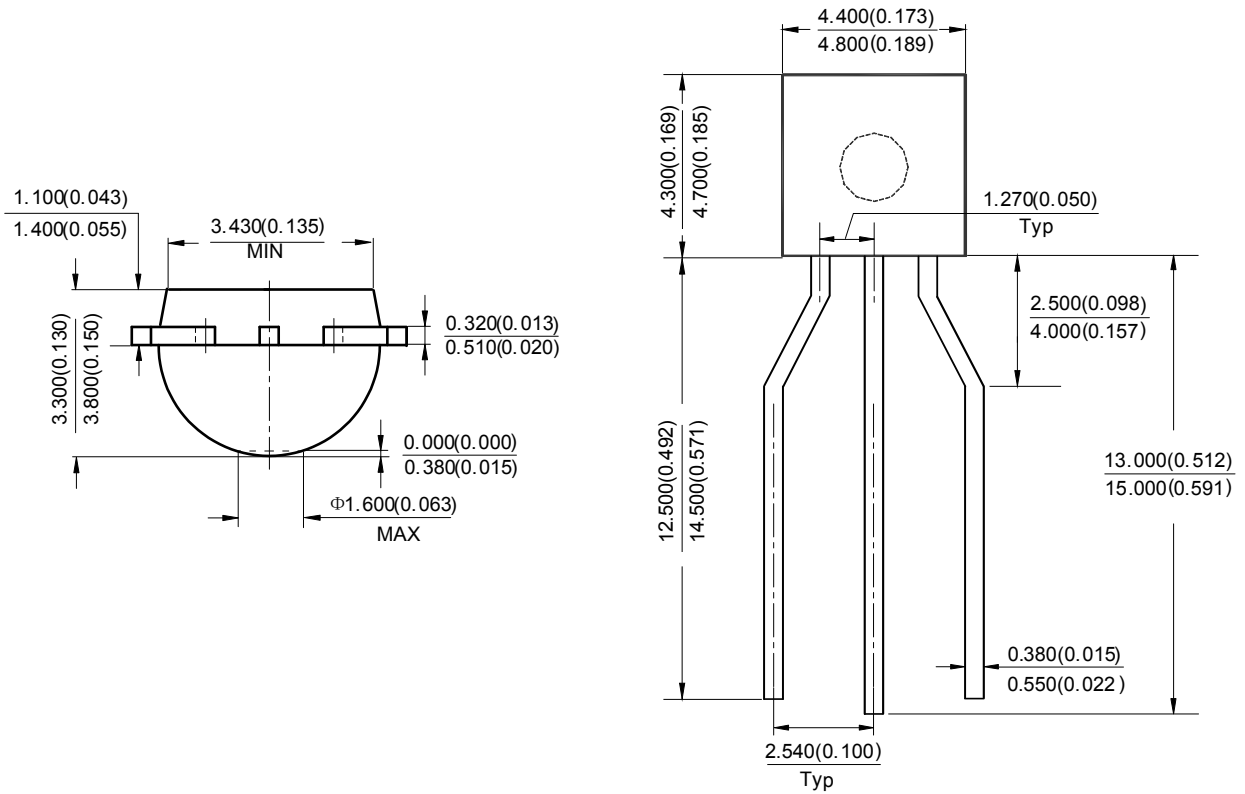



100mA POSITIVE VOLTAGE REGULATOR

AS78LXX

Mechanical Dimensions (Continued)

SOT-89

Unit: mm(inch)

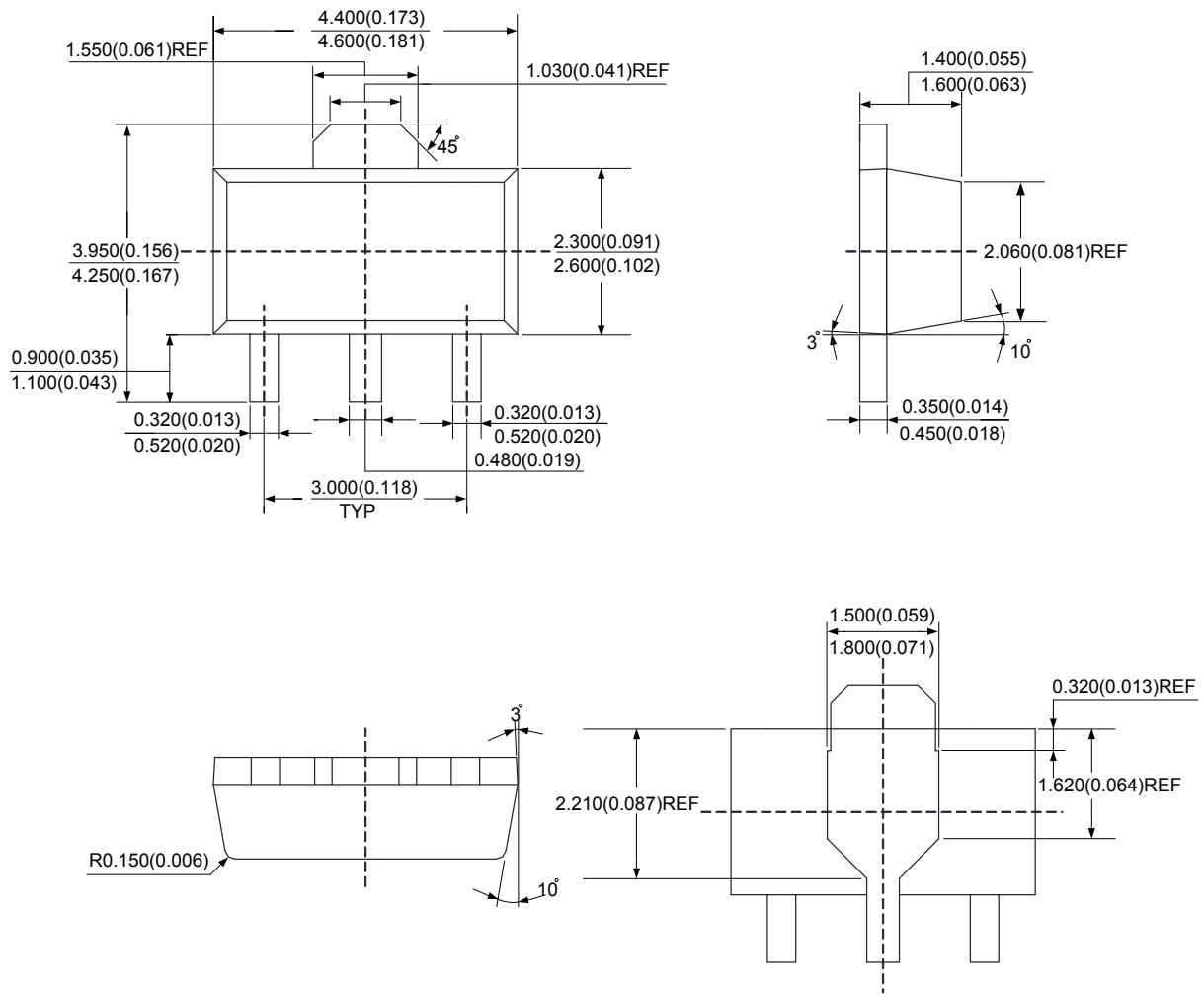



100mA POSITIVE VOLTAGE REGULATOR

AS78LXX

Mechanical Dimensions (Continued)

SOIC-8

Unit: mm(inch)

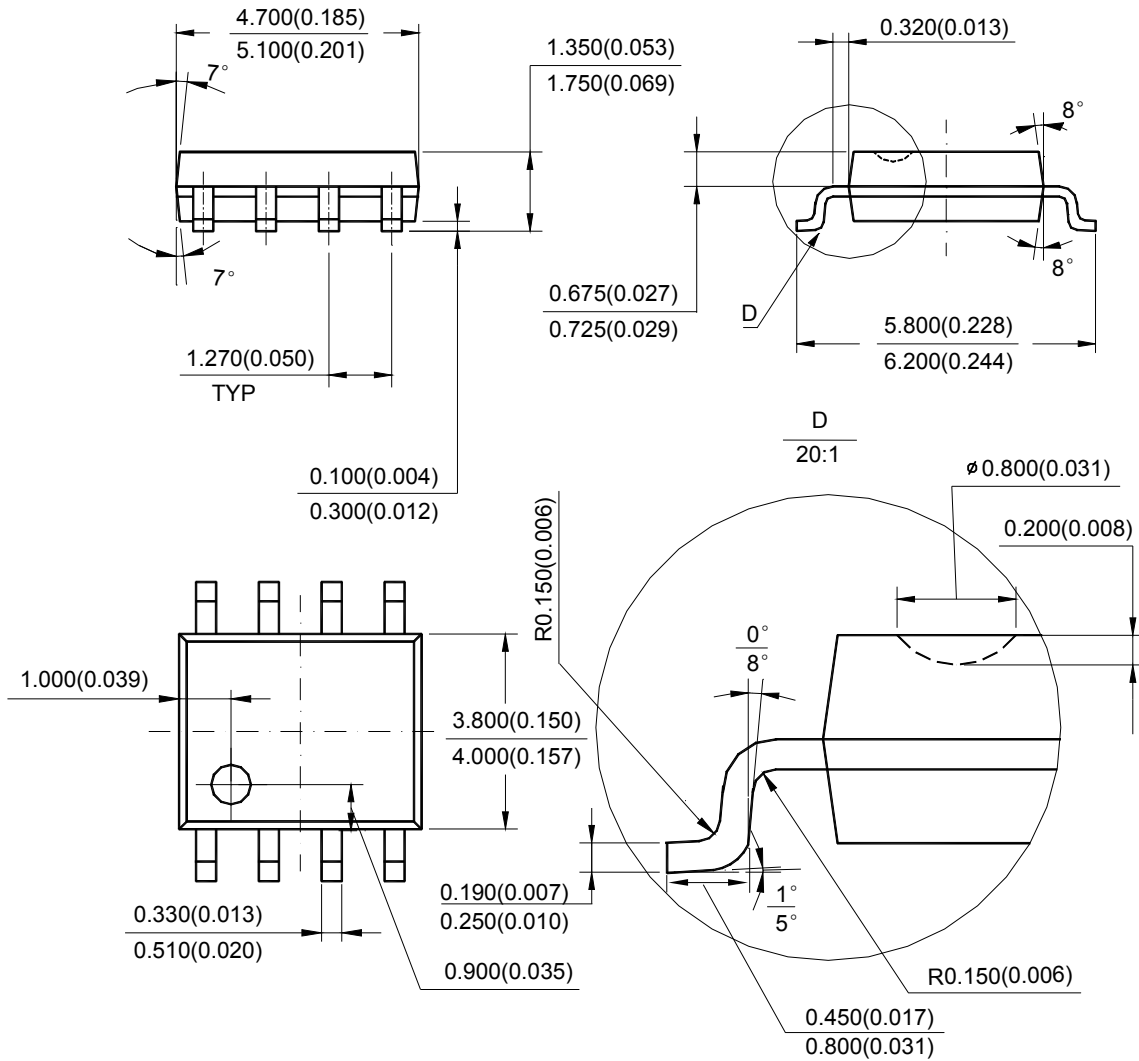

Note: Eject hole, oriented hole and mold mark is optional.



BCD Semiconductor Manufacturing Limited

<http://www.bcdsemi.com>

IMPORTANT NOTICE

BCD Semiconductor Manufacturing Limited reserves the right to make changes without further notice to any products or specifications herein. BCD Semiconductor Manufacturing Limited does not assume any responsibility for use of any its products for any particular purpose, nor does BCD Semiconductor Manufacturing Limited assume any liability arising out of the application or use of any its products or circuits. BCD Semiconductor Manufacturing Limited does not convey any license under its patent rights or other rights nor the rights of others.

MAIN SITE

- Headquarters

BCD Semiconductor Manufacturing Limited

No. 1600, Zi Xing Road, Shanghai ZiZhu Science-based Industrial Park, 200241, China
Tel: +86-21-24162266, Fax: +86-21-24162277

- Wafer Fab

Shanghai SIM-BCD Semiconductor Manufacturing Co., Ltd.

800 Yi Shan Road, Shanghai 200233, China
Tel: +86-21-6485 1491, Fax: +86-21-5450 0008

REGIONAL SALES OFFICE

Shenzhen Office

Shanghai SIM-BCD Semiconductor Manufacturing Co., Ltd., Shenzhen Office

Unit A Room 1203, Skyworth Bldg., Gaoxin Ave. 1.S., Nanshan District, Shenzhen, China
Tel: +86-755-8826 7951
Fax: +86-755-8826 7865

Taiwan Office

BCD Semiconductor (Taiwan) Company Limited

4F, 298-1, Rui Guang Road, Nei-Hu District, Taipei, Taiwan
Tel: +886-2-2656 2808
Fax: +886-2-2656 2806

USA Office

BCD Semiconductor Corp.

30920 Huntwood Ave. Hayward, CA 94544, USA
Tel : +1-510-324-2988
Fax: +1-510-324-2788