

## 16Mb, 512Kx32 CMOS 5.0V, High Speed Static RAM Integrated Plastic Encapsulated Microcircuit

### FEATURES

- Integrated Real-Time Memory Array Solution
  - No latency or refresh cycles
  - Parallel Read/Write Interface
  - User Configurable via multiple enables
- Random Access Memory Array
  - Fast Access Times: 12, 15, 20, and 25ns
  - TTL Compatible I/O
  - Fully Static, No Clocks
- Surface Mount Package
  - 68 Lead PLCC, No. 99 JEDEC M0-47AE
  - Small Footprint, 0.990 Sq. In.
  - Multiple Ground Pins for Maximum Noise Immunity
  - Single +5V (±5%) Supply Operation

### DESCRIPTION

The AS8S512K32 is a high speed, 5V, 16Mb SRAM. The device is available with access times of 12, 15, 20 and 25ns creating a zero wait state/latency, real-time memory solution. The high speed, 5v supply voltage and control lines, make the device ideal for all your real-time computer memory requirements.

The device can be configured as a 512K x 32 and used to create a single chip external data /program memory array solution or via use of the individual chip enable lines, be reconfigured as a 1M x 16 or 2M x 8.

The device provides a 50+% space savings when compared to four 512K x 8, 36 pin SOJs. In addition the AS8S512K32 has only a 20pF load on the Addr. lines vs. ~30pF for four plastic SOJs.

### PIN CONFIGURATIONS AND BLOCK DIAGRAM (PECA Package)

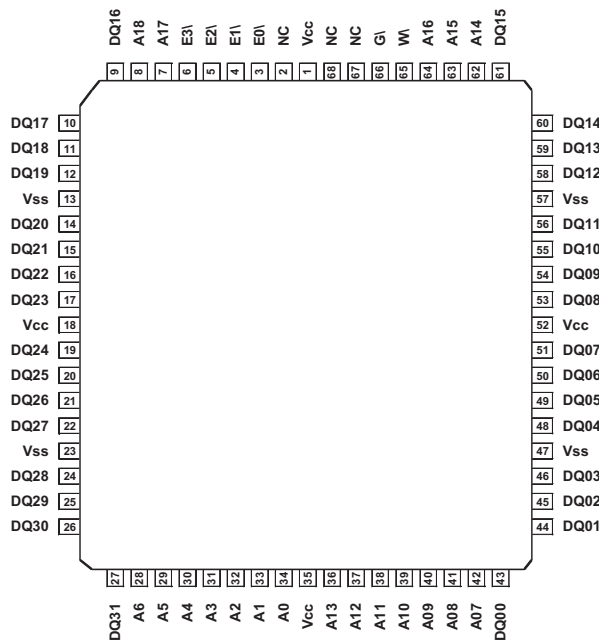

#### PIN NAMES

A0 - A18	Address Inputs
E0\ - E3\	Chip Enables
W\	Write Enables
G\	Output Enable
DQ0 - DQ31	Common Data Input/Output
Vcc	Power (+5V ± 10%)
Vss	Ground
NC	No Connection

#### BYTE CONTROL TABLE

Chip Enable	Byte Control
E0\	DQ0-7
E1\	DQ8-15
E2\	DQ16-23
E3\	DQ24-31

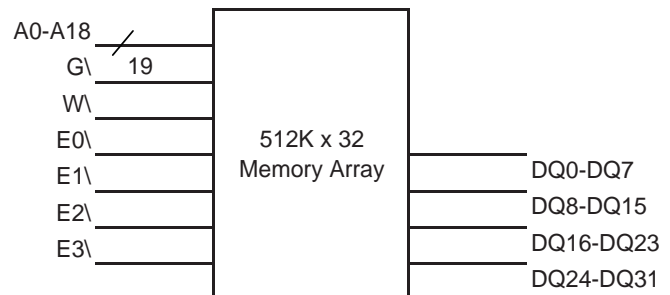

**ABSOLUTE MAXIMUM RATINGS\***

Voltage on any pin relative to V <sub>SS</sub>	-0.5V to 7.0V
Operating Temperature t <sub>A</sub> (Ambient)	
Industrial	-40°C to +85°C
Enhanced	-40°C to +105°C
Military	-55°C to +125°C
Storage Temperature, Plastic	-55°C to +125°C
Power Dissipation	5.0 Watts
Output Current	20 mA
Junction Temperature, T <sub>J</sub>	175°C

\*Stress greater than those listed under "Absolute Maximum Ratings" may cause permanent damage to the device. This is a stress rating only and functional operation of the device at these or any other conditions greater than those indicated in the operational sections of this specification is not implied. Exposure to absolute maximum rating conditions for extended periods may affect reliability.

**RECOMMENDED DC OPERATING CONDITIONS**

Parameter	Sym	Min	Typ	Max	Units
Supply Voltage	V <sub>CC</sub>	4.75	5	5.25	V
Supply Voltage	V <sub>SS</sub>	0	0	0	V
Input High Voltage	V <sub>IH</sub>	2.2	---	V <sub>CC</sub> +0.5V	V
Input Low Voltage	V <sub>IL</sub>	-0.3	---	0.8	V

**AC TEST CONDITIONS**

Input Pulse Levels	V <sub>SS</sub> to 3.0V
Input Rise and Fall Times	5ns
Input and Output Timing Levels	1.5V
Output Load	Figure 2

Note: For t<sub>EHQZ</sub>, t<sub>GHQZ</sub> and t<sub>WLQZ</sub>, CL=5pF

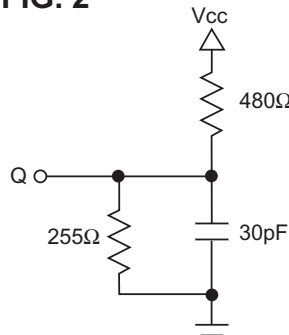
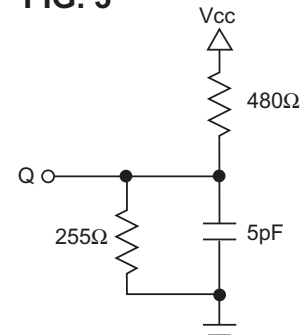
**FIG. 2**

**FIG. 3**

**DC ELECTRICAL CHARACTERISTICS**

Parameter	Sym	Conditions	Min	Max		Units
				12/15	20/25	
Operating Power Supply Current	I <sub>CC1</sub>	W#=V <sub>IL</sub> , I <sub>I/O</sub> =0mA, Min Cycle		350	300	mA
Standby (TTL) Power Supply Current	I <sub>CC2</sub>	E#≥V <sub>IH</sub> , V <sub>IN</sub> ≤V <sub>IL</sub> or V <sub>IN</sub> ≥V <sub>IH</sub> , f=0MHz		120	125	mA
Full Standby Power Supply Current CMOS	I <sub>CC3</sub>	E#≥V <sub>CC</sub> -0.2V V <sub>IN</sub> ≥V <sub>CC</sub> -0.2V or V <sub>IN</sub> ≤0.2V		20	20	mA
Input Leakage Current	I <sub>LI</sub>	V <sub>IN</sub> =0V to V <sub>CC</sub>		±5		μA
Output Leakage Current	I <sub>LO</sub>	V <sub>I/O</sub> =0V to V <sub>CC</sub>		±5		μA
Output High Voltage	V <sub>OH</sub>	I <sub>OH</sub> =-4.0mA	2.4			V
Output Low Voltage	V <sub>OL</sub>	I <sub>OL</sub> =8.0mA		0.4		V

**TRUTH TABLE**

G#	E#	W#	Mode	Output	Power
X	H	X	Standby	HIGH Z	I <sub>CC2</sub>
					I <sub>CC3</sub>
H	L	H	Output Deselect	HIGH Z	I <sub>CC1</sub>
L	L	H	Read	D <sub>OUT</sub>	I <sub>CC1</sub>
X	L	L	Write	D <sub>IN</sub>	I <sub>CC1</sub>

**CAPACITANCE**

(f=1.0MHz, V<sub>IN</sub>=V<sub>CC</sub> or V<sub>SS</sub>)

Parameter	Sym	Max	Unit
Address Lines	CI	20	pF
Data Lines	CD/Q	7	pF
Write & Output Enable Line	W#, G#	20	pF
Chip Enable Line	E0#, E3#	7	pF

**AC CHARACTERISTICS READ CYCLE**

Parameter	Symbol		12ns		15ns		20ns		25ns		Units
	JEDEC	Alt.	Min	Max	Min	Max	Min	Max	Min	Max	
Read Cycle Time	$t_{AVAV}$	$t_{RC}$	12		15		20		25		ns
Address Access Time	$t_{AVQV}$	$t_{AA}$		12		15		20		25	ns
Chip Enable Access	$t_{ELQV}$	$t_{ACS}$		12		15		20		25	ns
Chip Enable to Output in Low Z	$t_{ELQX}$	$t_{CLZ}$	3		3		3		3		ns
Chip Disable to Output in High Z	$t_{EHQZ}$	$t_{CHZ}$		6		7		9		9	ns
Output Hold from Address Change	$t_{AVQX}$	$t_{OH}$	3		3		3		3		ns
Output Enable to Output Valid	$t_{GLQV}$	$t_{OE}$		6		7		9		9	ns
Output Enable to Output in Low Z	$t_{GLQX}$	$t_{OLZ}$	0		0		0		0		ns
Output Enable to Output in High Z	$t_{GHQZ}$	$t_{OHZ}$		6		7		9		9	ns

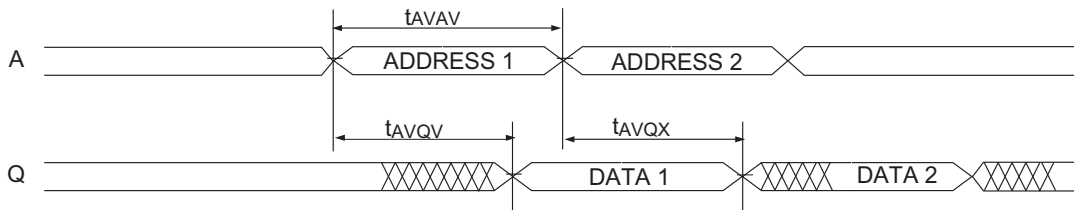
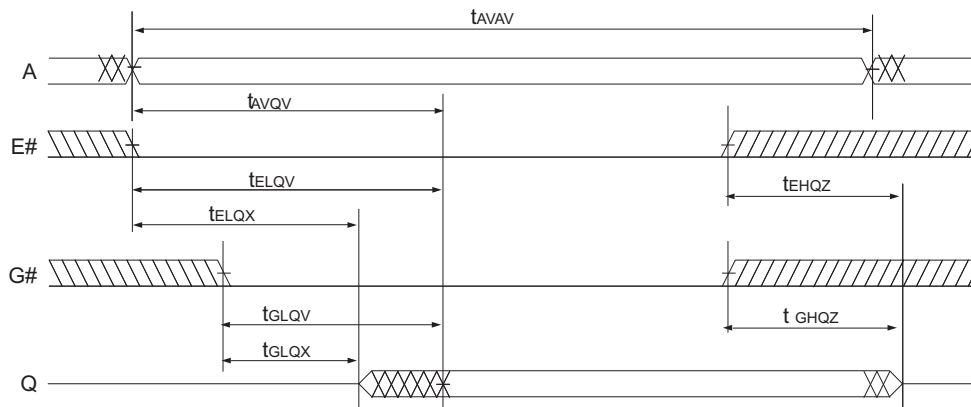
**READ CYCLE 1 - W HIGH, G#, E# LOW**

**READ CYCLE 2 - W HIGH**



AC CHARACTERISTICS READ CYCLE

Parameter	Symbol		12ns		15ns		20ns		25ns		Units
	JEDEC	Alt.	Min	Max	Min	Max	Min	Max	Min	Max	
Write Cycle Time	$t_{AVAV}$	$t_{WC}$	12		15		20		25		ns
Chip Enable to End of Write	$t_{ELWH}$	$t_{CW}$	8		10		11		12		ns
	$t_{ELEH}$	$t_{CW}$	8		10		11		12		ns
Address Setup Time	$t_{AVWL}$	$t_{AS}$	0		0		0		0		ns
	$t_{AVEL}$	$t_{AS}$	0		0		0		0		ns
Address Valid to End of Write	$t_{AVWH}$	$t_{AW}$	8		10		11		12		ns
	$t_{AVEH}$	$t_{AW}$	8		10		11		12		ns
Write Pulse Width	$t_{WLWH}$	$t_{WP}$	8		10		11		12		ns
	$t_{ELEH}$	$t_{WP}$	10		12		13		14		ns
Write Recovery Time	$t_{WHAZ}$	$t_{WR}$	0		0		0		0		ns
	$t_{EHAZ}$	$t_{WR}$	0		0		0		0		ns
Data Hold Time	$t_{WHDX}$	$t_{DH}$	0		0		0		0		ns
	$t_{EHDZ}$	$t_{DH}$	0		0		0		0		ns
Write to Output in High Z	$t_{WLQZ}$	$t_{WHZ}$	0	6	0	7	0	8	0	9	ns
Data to Write Time	$t_{DVWH}$	$t_{DW}$	6		7		8		9		ns
	$t_{DVEH}$	$t_{DW}$	6		7		8		9		ns
Output Active from End of Write	$t_{WHQX}$	$t_{WLZ}$	3		3		3		3		

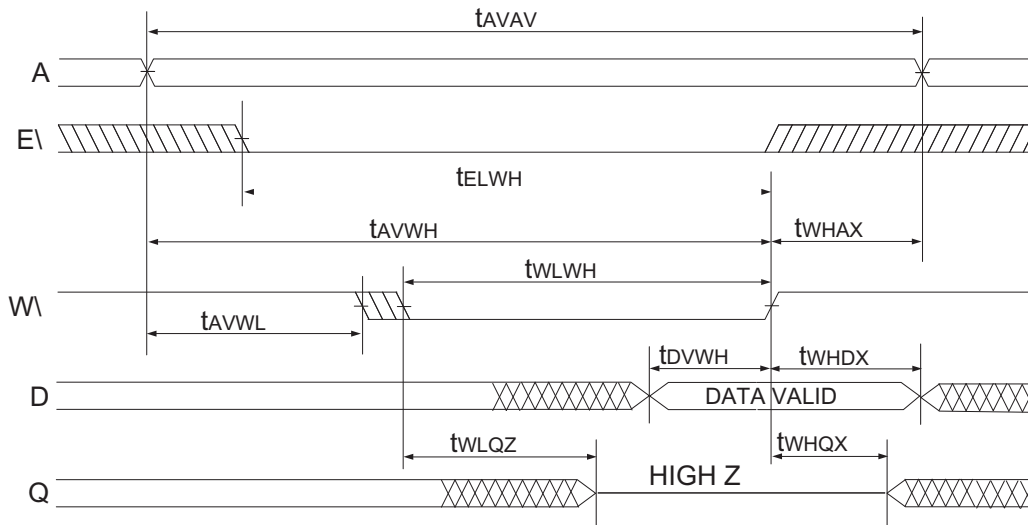
WRITE CYCLE 1 - W CONTROLLED



### WRITE CYCLE 2 - E\ CONTROLLED

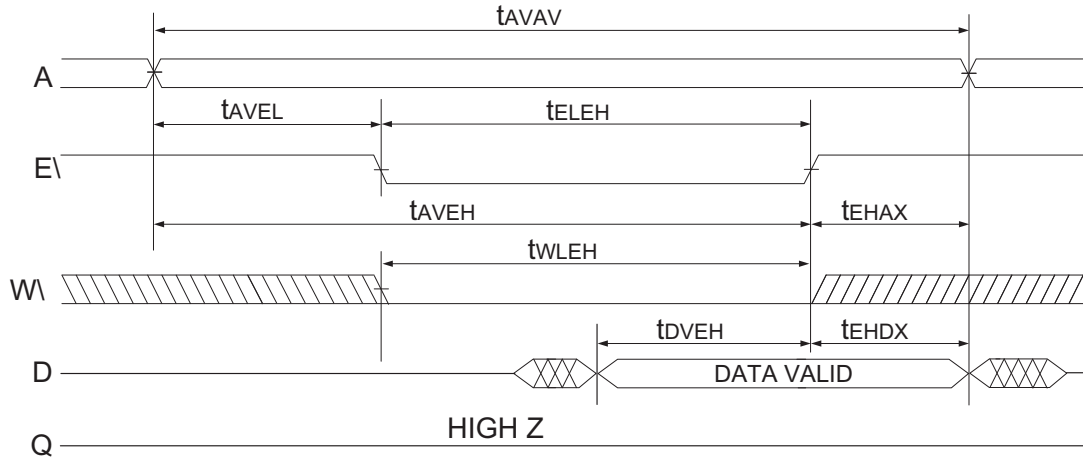

### PACKAGE DRAWING

Package No. 99  
68 Lead PLCC  
JEDEC MO-47AE

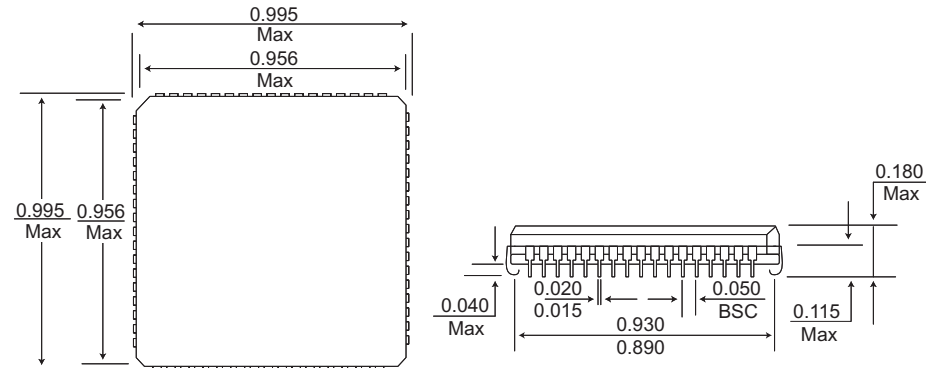



### FAMILY PIN MATRIX

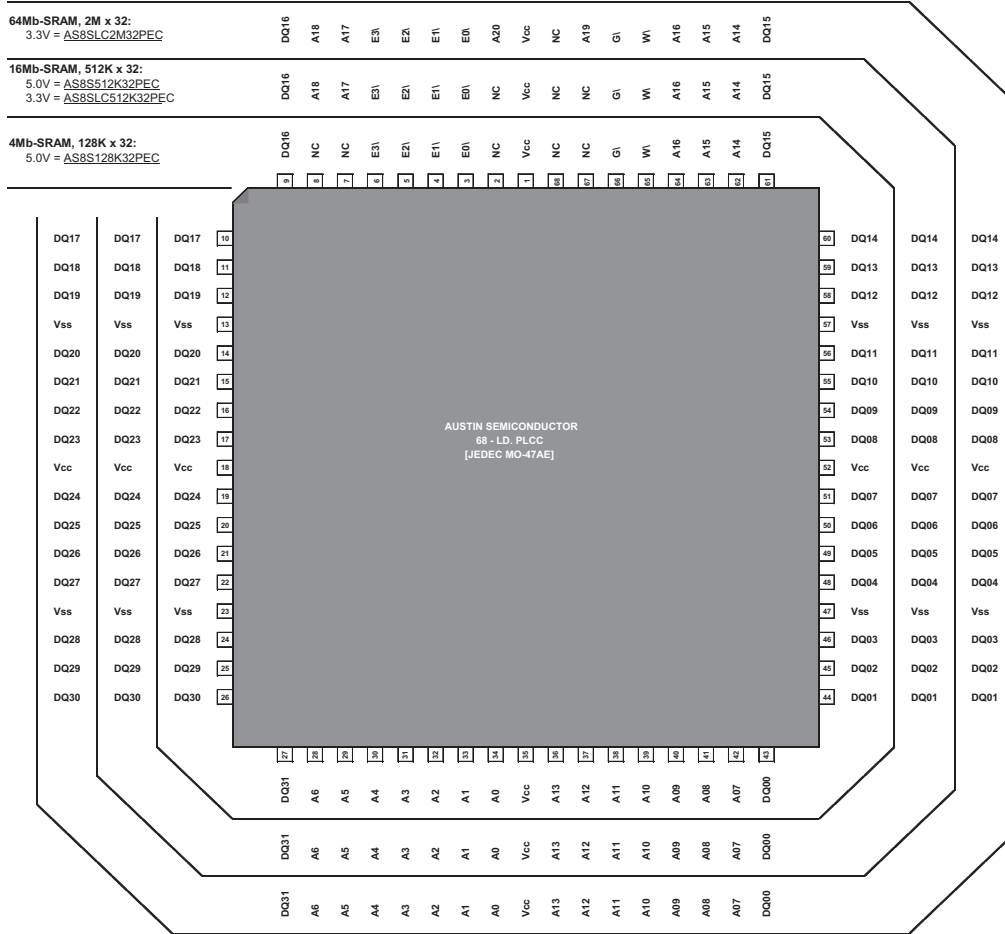



**ORDERING INFORMATION**

Part Number	Access Speed	Device Grade	Availability
AS8S512K32PEC-MS	NA	Mechanical Sample	Obsolete
AS8S512K32PEC-ES	NA	Engineering Sample	Obsolete
AS8S512K32PEC-12/IT	12ns	Industrial	Obsolete
AS8S512K32PEC-15/IT	15ns	Industrial	Obsolete
AS8S512K32PEC-20/IT	20ns	Industrial	Obsolete
AS8S512K32PEC-25/IT	25ns	Industrial	Obsolete
AS8S512K32PEC-12/ET	12ns	Enhanced	Obsolete
AS8S512K32PEC-15/ET	15ns	Enhanced	Obsolete
AS8S512K32PEC-20/ET	20ns	Enhanced	Obsolete
AS8S512K32PEC-25/ET	25ns	Enhanced	Obsolete
AS8S512K32PEC-12/XT	12ns	Military	Obsolete
AS8S512K32PEC-15/XT	15ns	Military	Obsolete
AS8S512K32PEC-20/XT	20ns	Military	Obsolete
AS8S512K32PEC-25/XT	25ns	Military	Obsolete
AS8S512K32PECA-12/IT	12ns	Industrial	Production
AS8S512K32PECA-15/IT	15ns	Industrial	Production
AS8S512K32PECA-20/IT	20ns	Industrial	Production
AS8S512K32PECA-25/IT	25ns	Industrial	Production
AS8S512K32PECA-12/ET	12ns	Enhanced	Production
AS8S512K32PECA-15/ET	15ns	Enhanced	Production
AS8S512K32PECA-20/ET	20ns	Enhanced	Production
AS8S512K32PECA-25/ET	25ns	Enhanced	Production
AS8S512K32PECA-12/XT	12ns	Military	Production
AS8S512K32PECA-15/XT	15ns	Military	Production
AS8S512K32PECA-20/XT	20ns	Military	Production
AS8S512K32PECA-25/XT	25ns	Military	Production

**DOCUMENT TITLE**

16Mb, 512K x 32, SRAM, 5.0V, 0.990”sq. - 68 LD. PLCC, Multi-Chip Package [iPEM]

**REVISION HISTORY**

<u>Rev #</u>	<u>History</u>	<u>Release Date</u>	<u>Status</u>
0.0	Initial Release	September 2005	Advance
0.1	Updated Order Chart	January 2009	Advance
0.2	Added Microcross Information	January 2010	Advance
0.3	Upgraded document to “Release” status. March 2011 Obsoleted and discontinued PEC package which had pin-out errors. Added PECA package reflecting correct pin-out. Contact Microcross for whitepaper addressing the pin-out error on the PEC package.		Release