

ASMedia Confidential for FAE

ASM1351 Datasheet



USB3.1 to SATA Bridge Controller

Copyright Notice:

Copyright © 2008, ASMedia TECHNOLOGY INC. All Rights Reserved.

INFORMATION IN THIS DOCUMENT IS PROVIDED IN CONNECTION WITH PRODUCTS OF ASMEDIA TECHNOLOGY INC. NO LICENSE, EXPRESS OR IMPLIED, BY ESTOPPEL OR OTHERWISE, TO ANY INTELLECTUAL PROPERTY RIGHTS IS GRANTED BY THIS DOCUMENT. EXCEPT AS PROVIDED IN ASMEDIA'S TERMS AND CONDITIONS OF SALE FOR SUCH PRODUCTS, ASMEDIA ASSUMES NO LIABILITY WHATSOEVER, AND ASMEDIA DISCLAIMS ANY EXPRESS OR IMPLIED WARRANTY, RELATING TO SALE AND/OR USE OF ASMEDIA PRODUCTS INCLUDING LIABILITY OR WARRANTIES RELATING TO FITNESS FOR A PARTICULAR PURPOSE, MERCHANTABILITY, OR INFRINGEMENT OF ANY PATENT, COPYRIGHT OR OTHER INTELLECTUAL PROPERTY RIGHT.

Products of ASMEDIA TECHNOLOGY INC. are not intended for use in medical, life saving, life sustaining, critical control or safety systems, or in nuclear facility applications.

ASMedia may make changes to specifications and product descriptions at any time, without notice.

ASMedia TECHNOLOGY INC. may have patents or pending patent applications, trademarks, copyrights, or other intellectual property rights that relate to the presented subject matter. The furnishing of documents and other materials and information does not provide any license, express or implied, by estoppel or otherwise, to any such patents, trademarks, copyrights, or other intellectual property rights.

Contact your local ASMedia sales office or your agent to obtain the latest specifications and before placing your product order.

Copies of documents which have an order number and are referenced in this document, or other ASMedia literature may be obtained by calling +886-2-22196088 or by visiting ASMedia's website at www.asmedia.com.tw.

ASMedia and ASMedia logo are trademarks or registered trademarks of ASMedia TECHNOLOGY INC. in Taiwan and other countries.

© 2008 祥碩科技股份有限公司，著作權所有，並保留一切權利

本文資料為與祥碩科技股份有限公司之產品相關。本文並未明示或默示授權任何智慧財產權予第三人。除在祥碩科技股份有限公司對該產品提供的買賣條款及條件以外，祥碩科技股份有限公司免於擔負任何責任，且不對產品的買賣及使用做任何明示或默示的保證，包含產品適於特殊使用目的、以及產品不侵害任何專利權、著作權或其他智慧財產權。祥碩科技股份有限公司之產品不用於醫療的、救助生命的、生命維持的、安全控管系統或核子設施等用途之上。

祥碩科技股份有限公司可隨時不經通知，逕行增訂或修改產品規格及描述。

本文之相關專利權、申請中之專利權、商標權、著作權及其餘智慧財產權均屬祥碩科技股份有限公司所有。本文及其他資訊並未明示或默示的提供任何專利、商標、著作權及其餘智慧財產權之授權。

請於下產品訂單前先聯絡當地的祥碩科技銷售處或代理商以取得最新的產品規格書。

本文提及之有訂單號碼之文件或其他詳細資料可參閱祥碩科技網站 www.asmedia.com.tw 或撥打 +886-2-22196088

ASMEDIA 和 ASMEDIA 商標均為祥碩科技股份有限公司在台灣和其他國家的註冊商標或商標。

Office:

ASMedia Technology, Inc.

6F, No.115, Minquan Rd., Xindian City, Taipei County 231, Taiwan, R.O.C.

<http://www.asmedia.com.tw>

Tel: 886-2-2219-6088

Fax: 886-2-2219-6080



Environmentally hazardous materials are not used in this product.

Revision History

Rev.	Date	Description
0.1	July 11, 2014	Initial Release

ASMedia Confidential for FAE

Table of Contents

Revision History	iii
Table of Contents	iv
List of Figures	v
1. General Description	1
2. Features	1
3. Package Type	1
4. Functional Diagram	2
5. Pinout Diagrams	3
6. Pin Descriptions	4
6.1 Strapping Table	5
7. Electrical Characteristics	6
7.1 Absolute Maximum Ratings	6
7.2 Recommended Operating Conditions	6
7.3 DC Electrical Characteristics for VBUS pins	6
7.4 DC Electrical Characteristics for GPIO pins	6
7.5 DC Electrical Characteristics for RST# pins	7
7.6 External Crystal Electrical Specification	7
7.7 Differential Clock Oscillator Electrical Specification	8
7.8 Internal Linear Regular Electrical Specification	8
7.9 Internal Switching Regular Electrical Specification	8
7.10 Power Consumption Characteristics	9
8. Power on Sequence	11
9. PCB Design Guide under Thermal Pad	12
10. Package Information	13
11. Top Marking Information	15

ASMedia Confidential for FAE

List of Figures

Figure 1: Functional Diagram of ASM1351	2
Figure 2: ASM1351 Pinout	3
Figure 3: Differential Crystal Design	7
Figure 4: Test point for power consumption.....	9
Figure 6: Test point	10
Figure 7: timing diagram	11
Figure 8: Symbol 1 for via design rule under Thermal pad.....	12
Figure 9: Symbol 2 for via design rule under Thermal pad.....	12
Figure 10: Mechanical Specification – QFN 48L.....	14

ASMedia Confidential for FAE

This page is intentionally left blank.

ASMedia Confidential for FAE

1. General Description

Engaged in Universal Serial Bus I/O solution and storage application development, ASMedia Technology is committed to expand product portfolio with introducing a new generation of USB3.1 to SATA 6Gbps bridge products.

ASM1351 is the latest generation of ASMedia single chip solution, bridging the USB3.1 to Serial ATA host interface with highly integrated SuperSpeedPlus USB3.1, SuperSpeed USB3.0, High Speed USB2.0 and SATA1.5/3.0/6.0 Gbps ASMedia self-designed PHYs. Along with excellent compatibility with USB3.1 hosts and SATA devices, ASM1351 uses advanced process technology to optimize the chip power consumption. Furthermore, it is also pin-to-pin backward compatible with existing ASM1153E.

Customers can easily enhance their storage device performance with ASM1351 since it also integrates an 8-bit micro-processor and embedded RAM to provide a cutting edge solution in USB to SATA device enclosure market.

2. Features

- ◇ Compliant with USB3.1 Specification Revision 1.0
- ◇ Compliant with USB Specification Revision 2.0
- ◇ Support USB Super-Speed Plus, USB Super-Speed, High-Speed and Full-Speed Operation
- ◇ Support USB Mass Storage Class, Bulk-Only Transport Specification Revision 1.3
- ◇ Support USB Attached SCSI Protocol Specification Revision 1.0
- ◇ Compliant with Serial ATA Specification Revision 3.2
- ◇ Serial ATA bus up to 6Gbps Signal bandwidth
- ◇ Support Spread Spectrum Control of USB3.0 and SATA interface to improve the EMI performance
- ◇ Support ATA/ATAPI Packet Command Set
- ◇ Support ATA/ATAPI LBA48 addressing mode
- ◇ Integrated 8-bit micro-processor with embedded program RAM and ROM
- ◇ Support SPI NVRAM for Vendor Specific Application of USB Device Controller
- ◇ Support multi-GPIO pins
- ◇ Support programmable PWMs
- ◇ Support 25/30MHz with external crystal mode
- ◇ Integrated two internal voltage regulator for IO power and Core

3. Package Type

- ◇ Green Package 6x6 QFN 48L (Pb-free)

4. Functional Diagram

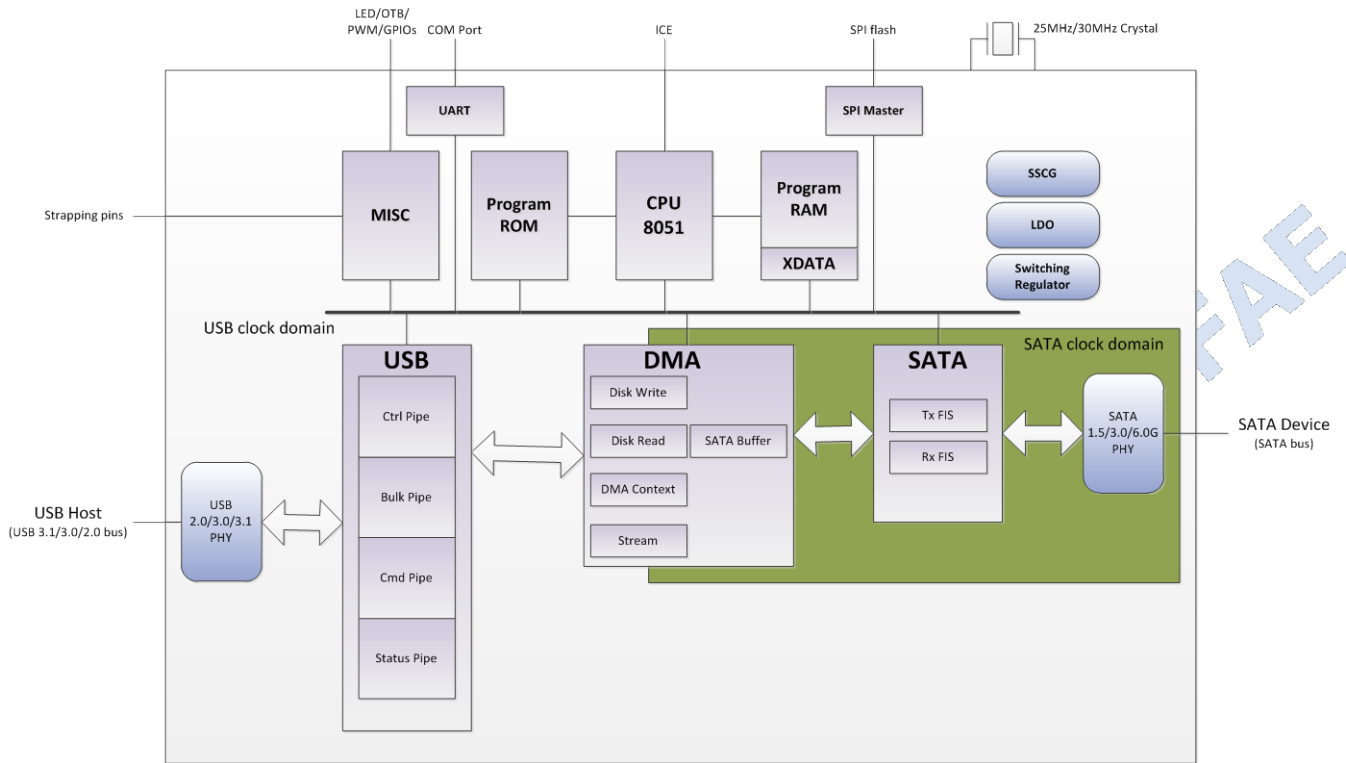

Figure 1: Functional Diagram of ASM1351

5. Pinout Diagrams

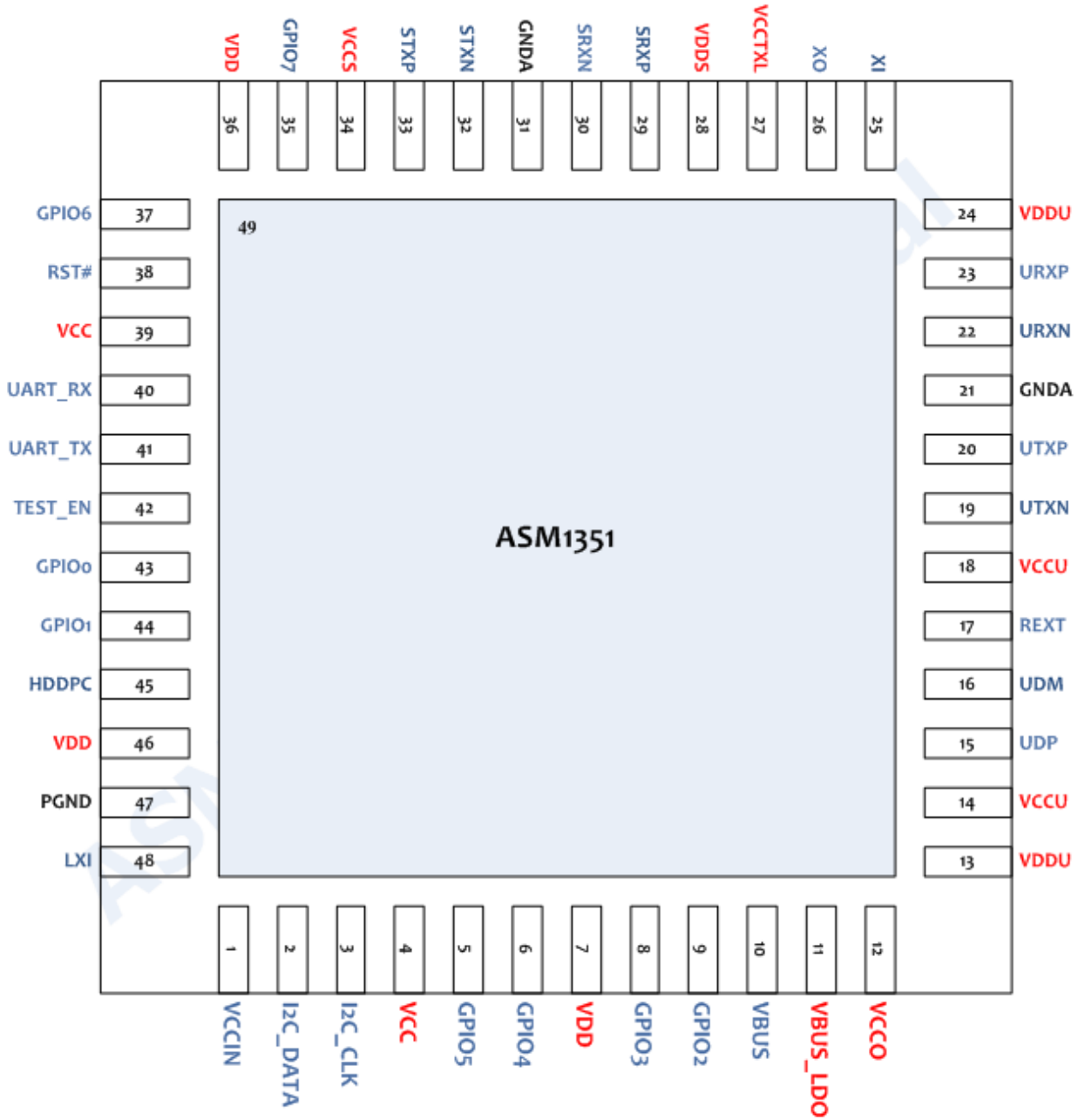

Figure 2: ASM1351 Pinout

6. Pin Descriptions

This section provides a detailed description of each signal. The following notations are used to describe the signal type.

I/O Type	Definition
I	Input pin
O	Output pin
B	Bi-directional pin
P	Power pin
G	Ground pin
OD	Open Drain

Pin No.	Name	TYPE	Descriptions
USB interface			
16	UDM	DB	USB2.0 negative Data Signal
15	UDP	DB	USB2.0 positive Data Signal
19	UTXN	DO	SuperSpeedPlus USB negative Transmitter Signal
20	UTXP	DO	SuperSpeedPlus USB positive Transmitter Signal
22	URXN	DI	SuperSpeedPlus USB negative Receiver Signal
23	URXP	DI	SuperSpeedPlus USB positive Receiver Signal
SATA interface			
29	SRXP	DI	SATA positive Receiver Signal
30	SRXN	DI	SATA negative Receiver Signal
32	STXN	DO	SATA negative Transmitter Signal
33	STXP	DO	SATA positive Transmitter Signal
System Signals			
42	TEST_EN	I	Test Enable Signal, with internal pull-down resistor 0: Normal Mode (Default) 1: Test Mode Enable
2	I2C_DATA	B	Used as I2C_DATA signal or SPI_DI signal, defined by strapping pin 37 GPIO6. Used as General Purpose IO after power on. Integrated pull-up resistor.
3	I2C_CLK	B	Used as I2C_CLK signal or SPI_CLK signal, defined by strapping pin 37 GPIO6. Used as General Purpose IO after power on. Integrated pull-up resistor.
5	GPIO5	B	General Purpose IO, used as SPI_DO, with internal pull-up resistor.
6	GPIO4	B	General Purpose IO, used as SPI_CS0, with internal pull-up resistor.
8	GPIO3	B	General Purpose IO, used as strapping pin for clock source select while power on. Refer to the strapping table. Integrated pull-up resistor.
9	GPIO2	B	General Purpose IO, used as SPI_CS1, with internal pull-up resistor.
35	GPIO7	B	General Purpose IO, use as strapping for clock source select while power on. Refer to the strapping table. Integrated pull-up resistor.
37	GPIO6	B	General Purpose IO, used as strapping for external ROM enabling via SPI interface. Refer to the strapping table. Integrated pull-up resistor.
40	UART_RX	B	UART_RX while debug mode, Used as General Purpose IO after power on. Integrated pull-up resistor.
41	UART_TX	B	UART_TX while debug mode, Used as General Purpose IO after power on. Integrated pull-up resistor.
43	GPIO0	B	General Purpose IO. Integrated pull-up resistor.
44	GPIO1	B	General Purpose IO. Integrated pull-up resistor.
45	HDDPC	B	HDD power control pin, use as General Purpose IO. Integrated pull-up resistor. 0: Hard Drive Power Off 1: Hard Drive Power On
10	VBUS	I	USB Cable Power Detector
17	REXT	P	External Reference Resistor with 12.1Kohm +/-1%
38	RST#	I	Power Reset pin
Clock Interface			

Pin No.	Name	TYPE	Descriptions
25	XI	I	Crystal input or Clock input pin
26	XO	O	Crystal output or Clock output pin
27	VCCTXL	P	Power for Crystal and PLL circuit
Voltage Regulator			
11	VBUS_LDO	P	Linear regulator input
12	VCCO	P	Linear regulator output
1	VCCIN	P	Switching regulator input
48	LXI	P	Connect with external inductor
47	PGND	G	Ground for voltage regulator
Power and Ground			
14, 18	VCCU	P	USB high power pin
34	VCCS	P	SATA high power pin
13, 24	VDDU	P	USB low power pin
28	VDDS	P	SATA low power pin
7, 36, 46	VDD	P	Core power
4, 39	VCC	P	IO power
21, 31	GNDA	G	Analog Ground
49	GND	G	the exposed pad connected to common ground on PCB

6.1 Strapping Table

Pin	Function	Description
GPIO[3]	Clock Select	0: 25MHz Crystal 1: 30MHz Clock Input

7. Electrical Characteristics

7.1 Absolute Maximum Ratings

Stresses the below parameter listed under absolute maximum rating may cause the device permanent damage. This is a stress rating only, and the function operating of the device at these or any other conditions over those parameter in the recommended operating condition is not implied. It is recommended to have a clamp circuit to protect the device with abnormal exhibit voltage spikes while power is switched on or off.

Parameter	Range	Unit
Power Supply for VCC	-0.5 ~ VCC+0.5	V
Power Supply for VDD	-0.5 ~ VDD+0.5	
DC Input Voltage	-0.5 ~ VCC+0.5	V
Output Voltage	-0.5 ~ VCC+0.5	V
Storage Temperature	JEDEC J-STD-033B MSL 3	

7.2 Recommended Operating Conditions

Symbols	Parameter	Min.	Typ.	Max.	Units
V _{CC}	IO Power Supply	3.0	3.3	3.6	V
V _{CCU}	USB Analog High Power Supply	3.0	3.3	3.6	V
V _{CCS}	SATA Analog High Power Supply	3.0	3.3	3.6	V
V _{DD}	Core Power Supply		1.2		V
V _{DDU}	USB Analog Low Power Supply		1.2		V
V _{DDS}	SATA Analog Low Power Supply		1.2		V
T _c	Operating Case Temperature	0	25	95	°C
T _J	Operating Junction Temperature	0	25	120	°C
HBM	Human Body mode ESD		-		KV
MM	Machine Mode ESD		-		V

7.3 DC Electrical Characteristics for VBUS pins

Symbols	Parameter	Min.	Typ.	Max.	Units
V _{IH}	Input High Level	2			V
V _{IL}	Input Low Level			0.8	V
V _{HYS}	Input Hysteresis	0.57	0.6	0.65	mV
V _{TH-L2H}	VTH of Schmitt Trigger low to high	1.4		1.8	V
V _{TH-H2L}	VTH of Schmitt Trigger high to low	0.85		1.10	V

7.4 DC Electrical Characteristics for GPIO pins

Symbols	Parameter	VCC=3.3V			Units
		Min.	Typ.	Max.	
V _{IH}	Input High Level	2			V
V _{IL}	Input Low Level			0.8	V
V _{HYS}	Input Hysteresis	0.57	0.6	0.65	mV
V _{TH-L2H}	VTH of Schmitt Trigger low to high	1.38	1.6	1.8	V
V _{TH-H2L}	VTH of Schmitt Trigger high to low	0.89	1.07	1.22	V
R _{UP}	Internal Pull-up resistance while Vin=0V	70	103	143	KΩ
	Internal Pull-up resistance while Vin=VCC/2 V	40	58.2	79.2	KΩ

Symbols	Parameter	VCC=3.3V			Units
		Min.	Typ.	Max.	
R _{DN}	Internal Pull-down resistance while Vin=0V	68	109	158	KΩ
	Internal Pull-down resistance while Vin=VCC/2 V	39	61.7	88	KΩ
I _{IL-UP}	Input pull-up current after Vin is read, Rup is off & Iil < 1uA when VIN=0	21	32	54	mA
	Input pull-up current after Vin is read, Rup is off & Iil < 1uA when VIN=VCC/2	19	28.4	48	mA
I _{IL-DN}	Input pull-down current after Vin is read, Rdn is off & Iil < 1uA when VIN=VCC	19	30.2	54	mA
	Input pull-down current after Vin is read, Rdn is off & Iil < 1uA when VIN=VCC/2	17	26.8	48	mA

7.5 DC Electrical Characteristics for RST# pins

Symbols	Parameter	Min.	Typ.	Max.	Units
V _{IH}	Input High Level	2.6			V
V _{IL}	Input Low Level			1.4	V
V _{HYS}	Input Hysteresis	0.218	0.235	0.25	V
V _{TH-L2H}	VTH of Schmitt Trigger low to high	1.88		2.58	V
V _{TH-H2L}	VTH of Schmitt Trigger high to low	1.65		2.35	V
I _{IL}	Input pull-up leakage current while Vin=0V			1	uA

7.6 External Crystal Electrical Specification

Note: please refer to the figure 3

Symbol	Parameter	Min.	Typ	Max.	Unit
f _{XTAL}	Frequency		25/30		MHz
Δf _{XTAL}	Long Term Stability (at 25°C)	-30		30	ppm
T _c	Temperature Stability	-30		30	ppm
F _A	Aging	-5		5	ppm
C _L	Load Capacitance (Single-end mode)		16		pF
C ₀	Shunt Capacitance	1	3	7	pF

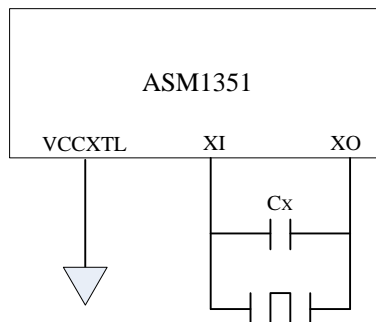

Figure 3: Differential Crystal Design

7.7 Differential Clock Oscillator Electrical Specification

Note: please refer to the figure 3

Symbol	Parameter	Min.	Typ	Max.	Unit
f_{CLK}	Frequency		25/30		MHz
Δf_{CLK}	Long Term Stability (all condition)	-150		150	ppm
C_x	External Load Capacitance (Differential mode)		10		pF
C_{TOTAL}	Total External Equivalent Capacitance from XI pin to XO pin (Differential mode)	9	11	15	Pf
R_{TOTAL}	Total External Equivalent Series Resistance from XI pin to XO pin			60	Ω

7.8 Internal Linear Regular Electrical Specification

Symbol	Parameter	Min.	Typ	Max.	Unit
V_{IN_LINEAR}	Input Voltage Range for internal linear regulator	4.5	5	5.5	V
V_{OUT_LINEAR}	Output Voltage Range for internal linear regulator	3.15	3.3	3.45	V
I_{MAX}	Maximum capacity of current output			200	mA

Notice: Please make sure the VCCIN is tied to 5V, even it uses the external 5V to 3.3V regulator.

7.9 Internal Switching Regular Electrical Specification

Symbol	Parameter	Min.	Typ	Max.	Unit
V_{IN_SWITCH}	Input Voltage Range for internal switching regulator	3.0		5.5	V
V_{OUT_SWITCH}	Output Voltage Range for internal switching regulator		1.2		V
ΔV_N (p-p)	3.3V input voltage noise/ripple Range	-8		8	%
F_{OSC}	OSC frequency		1.7		MHz
I_{MAX}	Maximum capacity of current output			300	mA
$IP_{(LM)}$	P-channel current limiter		1		A

- **Strong recommendation to have 10uF decoupling capacitor placed close to pin1 to filter the noise/ripple of 3.3V switching regulator input.**

7.10 Power Consumption Characteristics

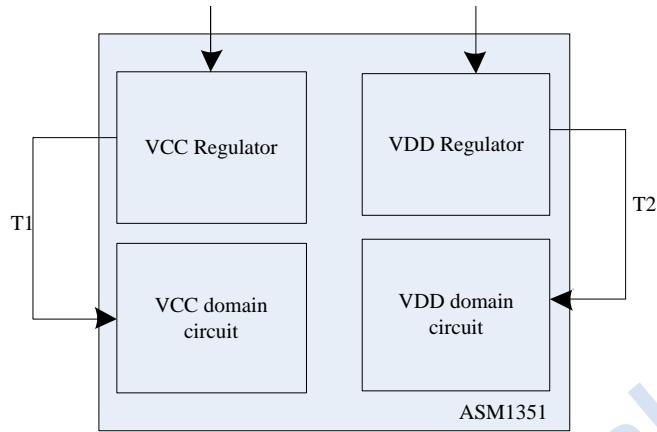

Figure 4: Test point for power consumption

Symbols	Parameter	Condition	USB3.1			USB3.0			USB2.0			Units
			Min.	Typ.	Max.	Min.	Typ.	Max.	Min.	Typ.	Max.	
I_{vcc}	Total current consumed for 3.3V power domain (Test point T1)	Operating										mA
		Idle										mA
		Suspend										mA
I_{vdd}	Total current consumed for 1.05V power domain (Test point T2)	Operating										mA
		Idle										mA
		Suspend										mA

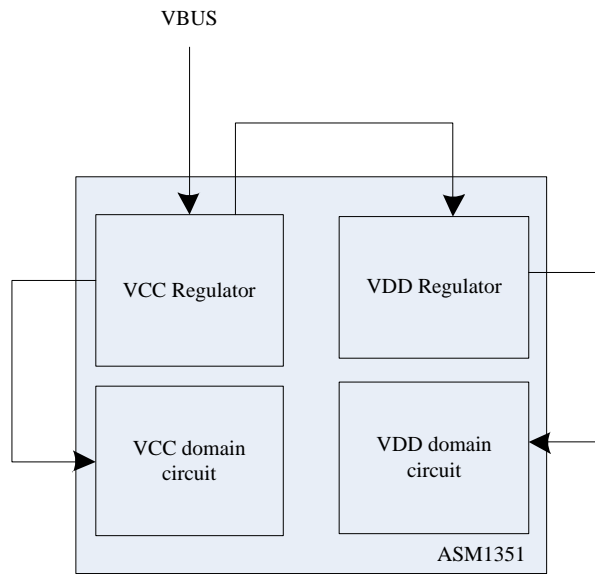

Figure 5: Test point

Symbols	Parameter	Condition	USB3.1			USB3.0			USB2.0			Units
			Min.	Typ.	Max.	Min.	Typ.	Max.	Min.	Typ.	Max.	
I_{VBUS}	Total current consumption for 5V (Test Point: Vbus)	Operating										mA
		Idle										mA
		Suspend										mA
P_{VBUS}	Total power consumption for 5V (Test Point: Vbus)	Operating										mW
		Idle										mW
		Suspend										mW

Notice: Different types of inductors used for internal switching regulator will have varying power consumption figures.

8. Power on Sequence

TBD

Figure 6: timing diagram

Symbols	Parameter	Min	Typ	Max	Unit	Remark
T1	The delay of VCC after VBUS is available				ms	Measure from 10% of VCC to 90% of VBUS For Self-powered system or external 5V to VCC regulator, this rule is not needed.
T2	The delay of VDD after VCC is available				ms	Measure from 10% of VCC to 90% of VDD For external VCC to VDD regulator, this rule is not needed.
T3	The delay of RST# after VCC is available				ms	Measure from 90% of RST# to 90% of VCC
T4	The crystal clock is stable after RST# and VDD is available				ms	Measure from 90% of VDD or 2V of RST#
T_{SLEW}	Slew rate of VDD				ms	Measure from 10% to 90% of VDD

ASMedia Confidential

9. PCB Design Guide under Thermal Pad

TBD

Figure 7: Symbol 1 for via design rule under Thermal pad

TBD

Figure 8: Symbol 2 for via design rule under Thermal pad

ASMedia Confidential for FAE

10. Package Information

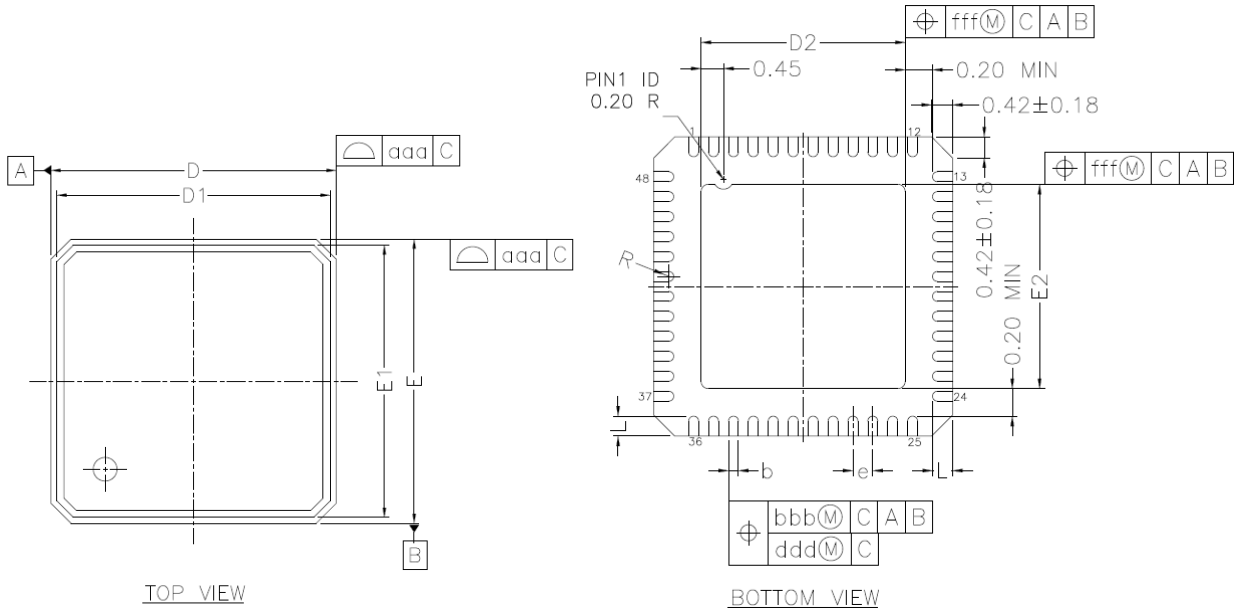

* CONTROLLING DIMENSION : MM

SYMBOL	MILLIMETER			INCH		
	MIN.	NOM.	MAX.	MIN.	NOM.	MAX.
A	0.80	0.85	0.90	0.031	0.033	0.035
A1	0.00	0.02	0.05	0.00	0.001	0.002
A2	0.60	0.65	0.70	0.024	0.026	0.028
A3	0.20 REF.			0.008 REF.		
b	0.15	0.20	0.25	0.006	0.008	0.010
D	6.00 bsc			0.236 bsc		
D1	5.75 bsc			0.226 bsc		
D2	3.95	4.10	4.25	0.156	0.161	0.167
E	6.00 bsc			0.236 bsc		
E1	5.75 bsc			0.226 bsc		
E2	3.95	4.10	4.25	0.156	0.161	0.167
L	0.30	0.40	0.50	0.012	0.016	0.020
e	0.40 bsc			0.016 bsc		
θ1	0°	---	14°	0°	---	14°
R	0.075	---	---	0.003	---	---
TOLERANCES OF FORM AND POSITION						
aaa	---	---	0.10	---	---	0.004
bbb	---	---	0.07	---	---	0.003
ccc	---	---	0.10	---	---	0.004
ddd	---	---	0.05	---	---	0.002
eee	---	---	0.08	---	---	0.003
fff	---	---	0.10	---	---	0.004

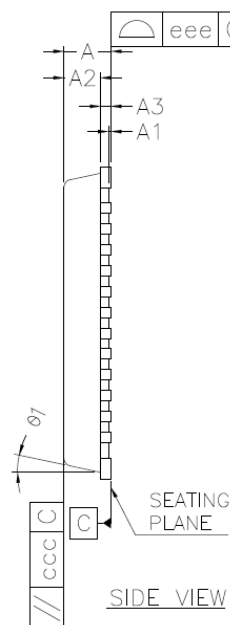

NOTES :

- 1.ALL DIMENSIONS ARE IN MILLIMETERS.
- 2.DIE THICKNESS ALLOWABLE IS 0.305 mm MAXIMUM(.012 INCHES MAXIMUM)
- 3.DIMENSIONING & TOLERANCES CONFORM TO ASME Y14.5M. –1994.
- 4.DIMENSION APPLIES TO PLATED TERMINAL AND IS MEASURED BETWEEN 0.20 AND 0.25 mm FROM TERMINALTIP.
- 5.THE PIN #1 IDENTIFIER MUST BE PLACED ON THE TOP SURFACE OF THE PACKAGE BY USING INDENTATION MARK OR OTHER FEATURE OF PACKAGE BODY.
- 6.EXACT SHAPE AND SIZE OF THIS FEATURE IS OPTIONAL.
- 7.PACKAGE WARPAGE MAX 0.08 mm.
- 8.APPLIED FOR EXPOSED PAD AND TERMINALS. EXCLUDE EMBEDDING PART OF EXPOSED PAD FROM MEASURING.
- 9.APPLIED ONLY TO TERMINALS.
- 10.PACKAGE CORNERS UNLESS OTHERWISE SPECIFIED ARE $R0.175\pm0.025$ mm.

Figure 9: Mechanical Specification – QFN 48L

ASMedia Confidential for FAE

11. Top Marking Information

TBD

ASMedia Confidential

ASMedia Confidential