

ASM17012CB

DATA SHEET

APLUS INTEGRATED CIRCUITS INC.

Address:

3 F-10, No. 32, Sec. 1, Chenggung Rd., Taipei,
Taiwan 115, R.O.C.
(115)台北市南港區成功路一段 32 號 3 樓之 10.

TEL: 886-2-2782-9266

FAX: 886-2-2782-9255

WEBSITE : <http://www.aplusinc.com.tw>

Sales E-mail: Mr. Jason

sales@aplusinc.com.tw

Technology E-mail: Mr. George

service@aplusinc.com.tw

ASM17012CB — VERY LOW-COST VOICE SYNTHESIZER WITH 4-BIT MICROPROCESSOR

1.0 General Description

The AM4DD1707 is very low cost voice synthesizer with 4-bit microprocessor. It has various features including 4-bit ALU, ROM, RAM, I/O ports, timers, clock generator, watchdog timer(WDT), voice synthesizer, etc. It consists of 22 instructions in the device. With CMOS technology and halt function can minimize power dissipation. Its architecture is similar to RISC, with two stages of instruction pipeline. It allows all instructions to be executed in a single cycle, except for program branches and data table read instructions (which need two instruction cycles).

1.1 Feature

- ◆ Single power supply can operate from 2.4V through 5.5V
- ◆ Internal Program ROM: 4K x 10-bit
- ◆ 1 sets of 19-bit DPR can access up to 512K x 10 bits data memory space
- ◆ Data Registers:
 - 96 x 4-bit data RAM (00-1Fh plus 40h-7Fh)
 - Unbanked special function registers (SFR) range: 20h-3Fh
- ◆ I/O Ports:
 - PRA: 4-bit I/O Port A (2Bh)
 - PRB: 4-bit Output Port B (2Dh)
 - PRC: 4-bit Input Port C (2Fh)
- ◆ On-chip clock generator: Resistive Clock Drive(**RM**)
- ◆ Timer: 1
 - Timer0: a 9-bit auto-reload timer/counter
- ◆ Stack: 2-level subroutine nesting
- ◆ HALT and Release from HALT function to reduce power consumption
- ◆ Watch Dog Timer (**WDT**)
- ◆ Instruction: 1-cycle instruction except for table read and program branches which are 2-cycles
- ◆ Number of instruction: 22
- ◆ The Voice function can be implemented by microprocessor instruction
 - One 8-bit COUT output for ASMxxxxx

FIGURE 1.1 : Block Diagram of ASM17012CB

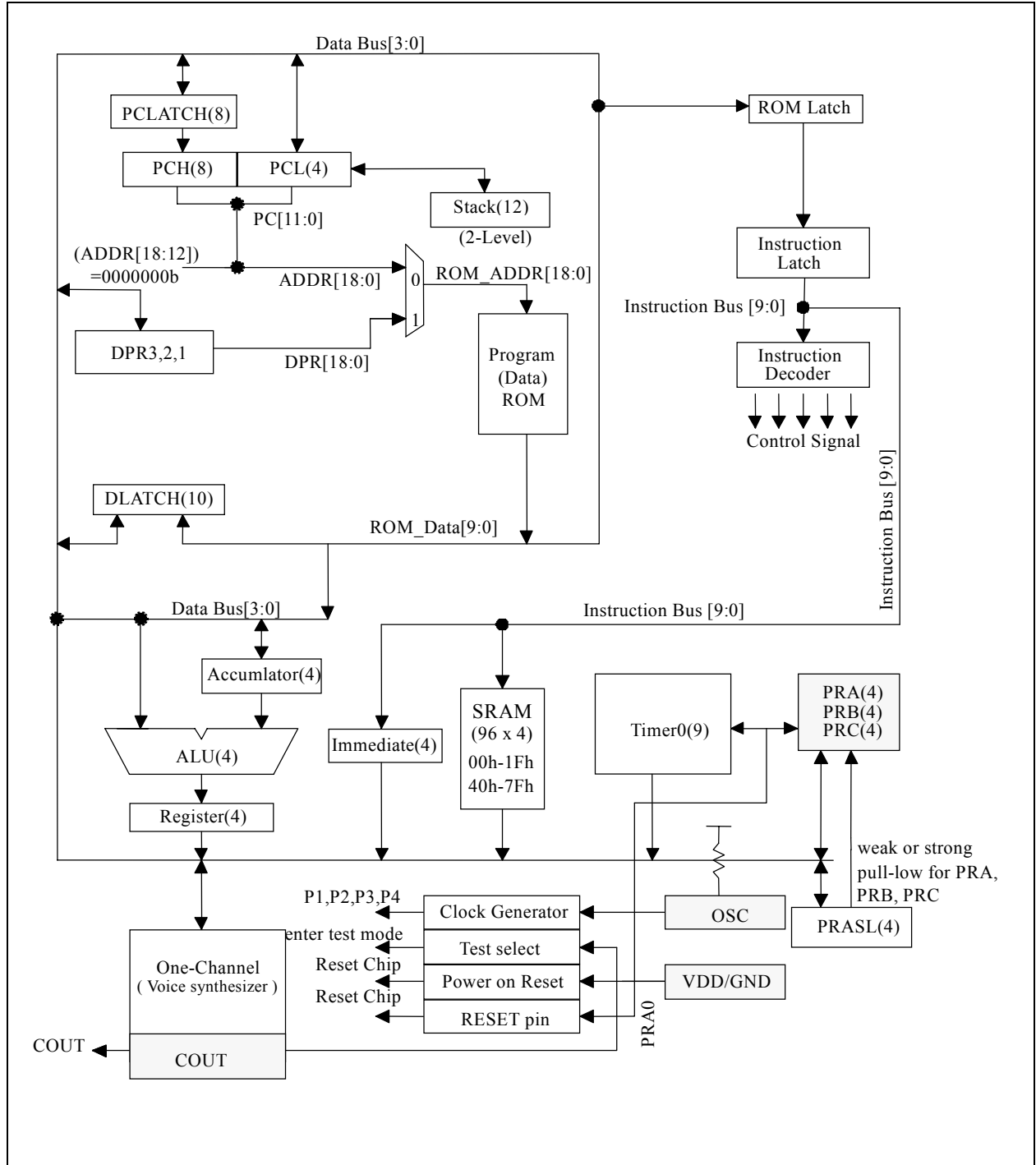
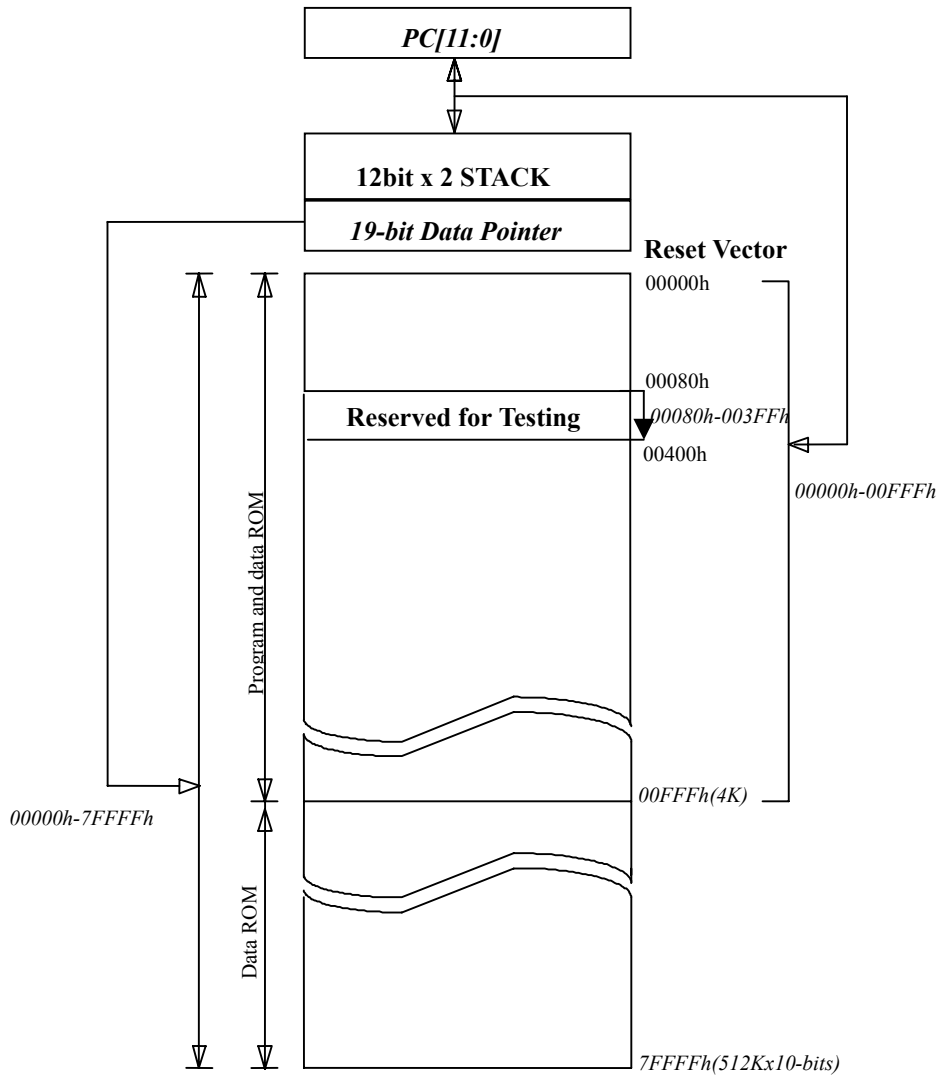

FIGURE 1.2 : External ROM Map of ASM17012CB



1.2 Pin-Out

ASM17012CB Pin-Out			
VDD3	I	-	Third Power supply during operation
PRC1	I	STI Std./O.D.	Input port with programmable strong pull-low or weak pull-low or fix-input-floating capability
PRC0/RESET	I	STI Std./O.D.	Input port with programmable strong pull-low or weak pull-low or fix-input-floating capability <i>Mask option selected as an external RESET pin with weak pull-low capability</i>
PRA3-1	I/O	STI Std./O.D.	I/O port with programmable strong pull-low or weak pull-low or fix-input-floating capability Output type with standard or Open-Drain output
PRA0/RESET	I/O	STI Std./O.D.	I/O port with programmable strong pull-low or weak pull-low or fix-input-floating capability Output type with standard or Open-Drain output <i>Mask option selected as an external RESET pin with weak pull-low capability</i>
OSC	I	-	RM mode Oscillator input
VDD1	I	-	First Power supply during operation
COUT	O	-	Current Output of Audio
GND1	I	-	First Circuit Ground Potential
GND2	I	-	Second Circuit Ground Potential
TEST	O	-	Enter Test Mode. (TEST = High)
VDD2	I	-	Second Power supply during operation
PRB0-3	O	Std./O.D.	Output type with standard or Open-Drain output
PRC2-3	I	STI Std./O.D.	Input port with programmable strong pull-low or weak pull-low or fix-input-floating capability
GND3	I	-	Third Circuit Ground Potential

1.3 Application circuit

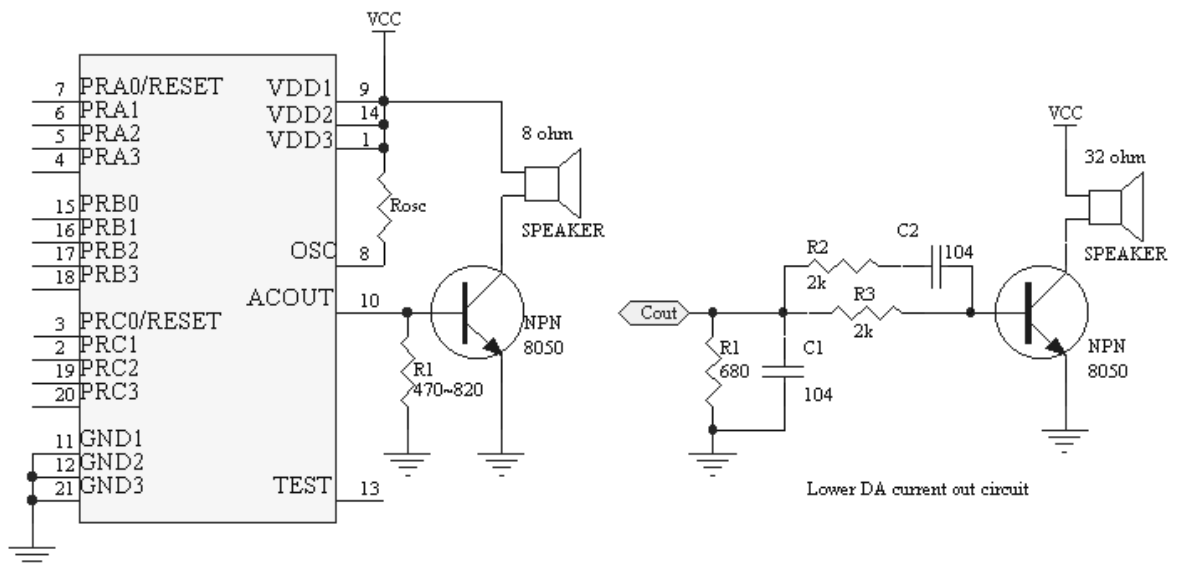

1.4 Bonding Diagram

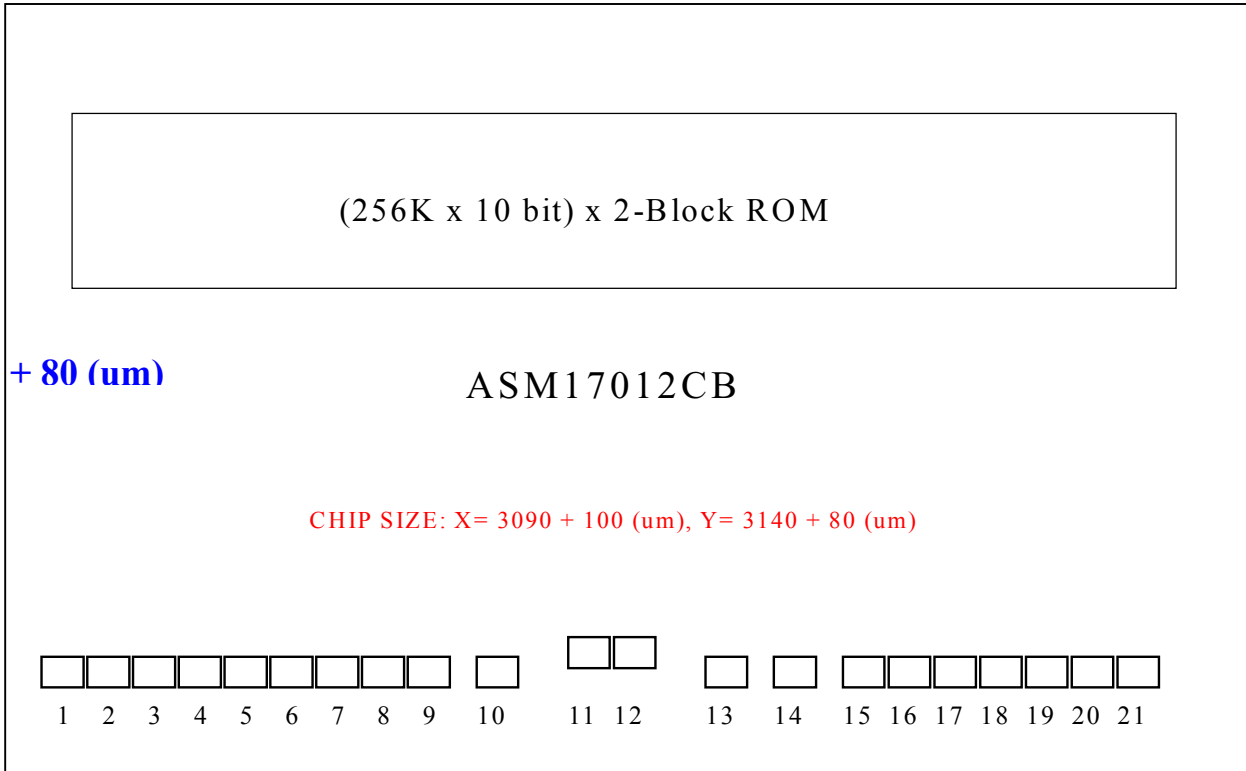

Y= 3140 + 80 (um)

X= 3090 + 100 (um)

Substrate must be connected to GND.

ASM17012CB Pad Location				Chip Size: X= 3090 + 100 (um) , Y= 3140 + 80 (um)			
PAD #	PAD Name	X	Y	PAD #	PAD Name	X	Y
1	VDD3	-1445.96	-1456.08	12	GND2	118.72	-1450.56
2	PRC1	-1325.24	-1456.08	13	TEST	319.68	-1456.08
3	PRC0	-1202.92	-1456.08	14	VDD2	575.32	-1456.08
4	PRA3	-1080.6	-1456.08	15	PRB0	714.48	-1456.08
5	PRA2	-958.28	-1456.08	16	PRB1	836.8	-1456.08
6	PRA1	-835.96	-1456.08	17	PRB2	959.12	-1456.08
7	PRA0/RESET	-713.64	-1456.08	18	PRB3	1081.44	-1456.08
8	OSC	-591.32	-1456.08	19	PRC2	1203.76	-1456.08
9	VDD1	-414.36	-1456.08	20	PRC3	1326.08	-1456.08
10	COUT	-162.24	-1456.08	21	GND3	1449.36	-1456.08
11	GND1	38.72	-1450.56				

1.5 DC Characteristics for ASMXXXXX

SYMBOL	PARAMETER	VDD	MIN.	TYP.	MAX.	UNIT	CONDITION
VDD	OPERATING VOLTAGE		2.4	3	5.0	V	depending on Freq.
Isb	SUPPLY CURRENT	STANDBY	3		1	uA	4MHz, RM in HALT Mode
			5		1		
Iop		OPERATING	3	2		mA	4MHz, RM IO Floating
			5	7			
Iih	INPUT CURRENT /Internal pull low		3	3		uA	4MHz, RM in HALT Mode (IO Ports with weak pull-high pull-low)
			5	9			
			5	-5.2			
Ioh	OUTPUT HIGH CURRENT		3	-3		mA	4MHz, RM (IO ports)
			5	-8			
Iol	OUTPUT LOW CURRENT		3	7		mA	4MHz, RM (IO ports)
			5	20			
Cout	DA CURRENT OUT (FULL SCALE)		3	4		mA	4MHz, RM (IO ports)
			5	5.2			
dF/F	FREQUENCY STABILITY		-10		10	%	$\frac{F_{osc}(3v-2.4v)}{F_{osc}(3v)}$
dF/F	Fosc VARIATION		-20		20	%	VDD=3V, Rosc=780k, 4MHz

FIGURE 1.3 : Frequency Range for Rosc in RM mode

Resistor(k ohm)	1000	760	560	390
3v Freq.(MHz)	3.18	4.1	5.4	7.69

