



Low Voltage Zero Delay Buffer

Features

- Fully Integrated PLL
- Up to 200MHz I/O Frequency
- LVCMOS Outputs
- Outputs Disable in High Impedance
- LVPECL Reference Clock Options
- LQFP Packaging
- ±50pS Cycle–Cycle Jitter
- 150pS Output Skews

Functional Description

The ASM5I961P is a 2.5V or 3.3V compatible, 1:18 PLL based zero delay buffer. With output frequencies of up to 200MHz, output skews of 150pS the device meets the needs of the most demanding clock tree applications.

The ASM5I961P is offered with two different input configurations. The ASM5I961P offers an LVCMOS

reference clock while the ASM5I961P offers an LVPECL reference clock.

When pulled high the \overline{OE} pin will force all of the outputs (except QFB) into a high impedance state. Because the \overline{OE} pin does not affect the QFB output, down stream clocks can be disabled without the internal PLL losing lock.

The ASM5I961P is fully 2.5V or 3.3V compatible and requires no external loop filter components. All control inputs accept LVCMOS compatible levels and the outputs provide low impedance LVCMOS outputs capable of driving terminated 50Ω transmission lines. For series terminated lines the ASM5I961P can drive two lines per output giving the device an effective fanout of 1:36. The device is packaged in a 32 lead LQFP package to provide the optimum combination of board density and performance.

Block Diagram

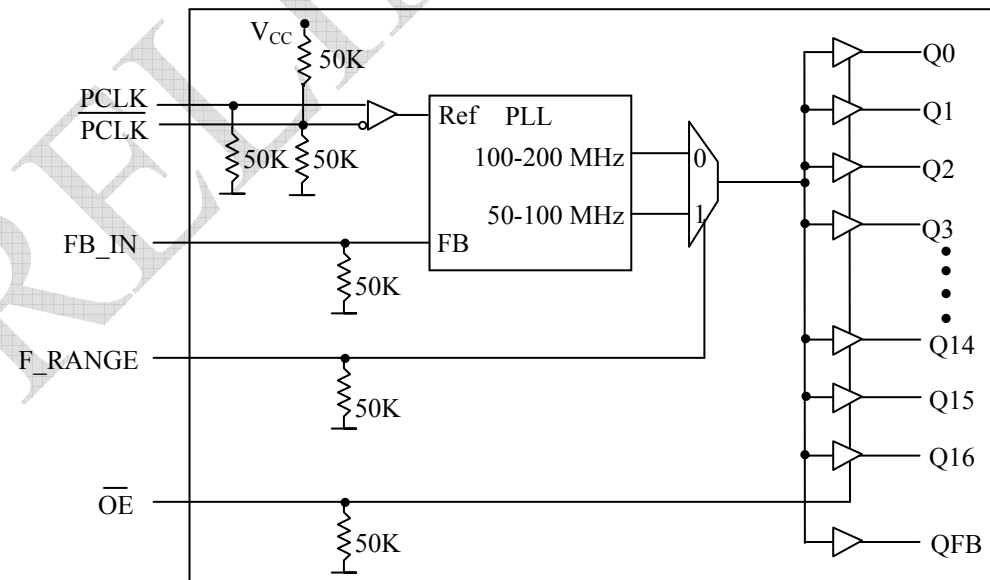

Figure 1. ASM5I961P Logic Diagram



rev 0.2

Pin Configuration

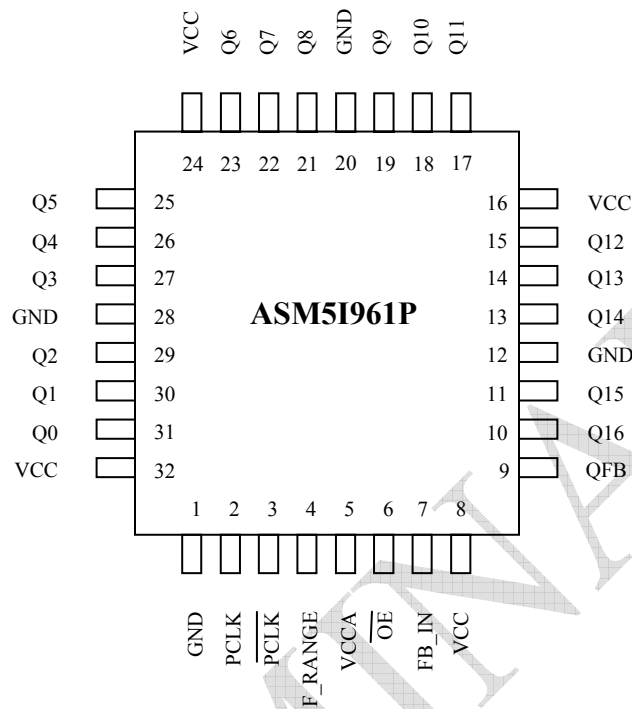

Figure 2. ASM51961P 32-Lead Package Pinout (Top View)

Table 1: Pin Configuration

Pin #	Pin Name	I/O	Type	Function
2,3	PCLK, $\overline{\text{PCLK}}$	Input	LVC MOS	PLL reference clock signal
7	FB_IN	Input	LVC MOS	PLL feedback signal input, connect to a QFB output
4	F_RANGE	Input	LVC MOS	PLL frequency range select
6	$\overline{\text{OE}}$	Input	LVC MOS	Output enable/disable
31,30,29,27,26,25,23,22,21,19,18,17,15,14,13,11,10	Q0 - Q16	Output	LVC MOS	Clock outputs
9	QFB	Output	LVC MOS	PLL feedback signal output, connect to a FB_IN
1,12,20,28	GND	Supply	Power	Negative power supply
5	VCCA	Supply	Power	PLL positive power supply (analog power supply). The ASM51961P requires an external RC filter for the analog power supply pin VCCA. Please see applications section for details.
8,16,24,32	VCC	Supply	Power	Positive power supply for I/O and core



rev 0.2

Table 2: Function Table

Control	Default	0	1
F_RANGE	0	PLL high frequency range. ASM51961P input reference and output clock frequency range is 100 – 200 MHz	PLL low frequency range. ASM51961P input reference and output clock frequency range is 50 – 100 MHz
$\overline{\text{OE}}$	0	Outputs enabled	Outputs disabled (high-impedance state)

Table 3: Absolute Maximum Ratings

Symbol	Parameter	Min	Max	Unit
V _{CC}	Supply Voltage	-0.3	3.6	V
V _{IN}	DC Input Voltage	-0.3	V _{CC} + 0.3	V
V _{OUT}	DC Output Voltage	-0.3	V _{CC} + 0.3	V
I _{IN}	DC Input Current		±20	mA
I _{OUT}	DC Output Current		±50	mA
T _S	Storage Temperature Range	-40	125	°C
T _{DV}	Static Discharge Voltage (As per JEDEC STD 22- A114-B)		2	KV

Note: These are stress ratings only and are not implied for functional use. Exposure to absolute maximum ratings for prolonged periods of time may affect device reliability.

Table 4: DC Characteristics (V_{CC} = 3.3V ± 5%, T_A = -40°C to +85°C)

Symbol	Characteristic	Min	Typ	Max	Unit	Condition
V _{IH}	Input HIGH Voltage	2.0		V _{CC} + 0.3	V	LVC MOS
V _{IL}	Input LOW Voltage	-0.3		0.8	V	LVC MOS
V _{PP}	Peak-to-peak input voltage ¹ PECL_CLK, $\overline{\text{PECL_CLK}}$	500		1000	mV	LVPECL
V _{CMR}	Common Mode Range ¹ PECL_CLK, $\overline{\text{PECL_CLK}}$	1.2		V _{CC} - 0.8	V	LVPECL
V _{OH}	Output HIGH Voltage	2.4			V	I _{OH} = -20mA ²
V _{OL}	Output LOW Voltage			0.55	V	I _{OL} = 20mA ²
Z _{OUT}	Output Impedance		14	20	Ω	
I _{IN}	Input Current			±120	mA	
C _{IN}	Input Capacitance		4.0		pF	
C _{PD}	Power Dissipation Capacitance		8.0	10	pF	Per Output
I _{CCA}	Maximum PLL Supply Current		2.0	5.0	mA	V _{CCA} Pin
I _{CC}	Maximum Quiescent Supply Current				mA	All V _{CC} Pins
V _{TT}	Output Termination Voltage		V _{CC} ±2		V	

Notes:

- Exceeding the specified V_{CMR}/V_{PP} window results in a t_{PD} changes of approx. 250pS.
- The ASM51961P is capable of driving 50Ω transmission lines on the incident edge. Each output drives one 50Ω parallel terminated transmission line to a termination voltage of V_{TT}. Alternatively, the device drives up two 50Ω series terminated transmission lines.



rev 0.2

Table 5: AC Characteristics ($V_{CC} = 3.3V \pm 5\%$, $T_A = -40^\circ\text{C}$ to $+85^\circ\text{C}$)¹

Symbol	Characteristic		Min	Typ	Max	Unit	Condition
f_{ref}	Input Frequency	F_RANGE = 0 F_RANGE = 1	100 50		200 100	MHz	
f_{max}	Maximum Output Frequency	F_RANGE = 0 F_RANGE = 1	100 50		200 100	MHz	
f_{refDC}	Reference Input Duty Cycle		25		75	%	
$t_{(\phi)}$	Propagation Delay ² (static phase offset)	PECL_CLK to FB_IN	-50		225	pS	PLL locked
$t_{sk(O)}$	Output to Output Skew ³			90	150	pS	
DCO	Output Duty Cycle	F_RANGE = 0 F_RANGE = 1	42 45	50 50	55 55	%	
t_r, t_f	Output Rise/Fall Time		0.1		1.0	nS	0.55 to 2.4V
$t_{PLZ,HZ}$	Output Disable Time				10	nS	
$t_{PZL,LZ}$	Output Enable Time				10	nS	
$t_{JIT(CC)}$	Cycle to Cycle Jitter	RMS (1σ) ⁴			15	pS	
$t_{JIT(PER)}$	Period Jitter	RMS (1σ)		7.0	10	pS	
$t_{JIT(\phi)}$	I/O Phase Jitter	RMS (1σ) F_RANGE = 0 F_RANGE = 1			$0.0015 \cdot T$ $0.0010 \cdot T$	nS	T = Clock Signal Period
t_{lock}	Maximum PLL Lock Time				10	mS	

Notes:

1. AC characteristics apply for parallel output termination of 50Ω to V_{TT} .
2. t_{PD} applies for $V_{CMR} = V_{CC} - 1.3V$ and $V_{PP} = 800mV$
3. See applications section for part to part skew calculation
4. See applications section for calculation for other confidence factors than 1σ

Table 6: DC Characteristics ($V_{CC} = 2.5V \pm 5\%$, $T_A = -40^\circ$ to 85°C)

Symbol	Characteristic	Min	Typ	Max	Unit	Condition
V_{IH}	Input HIGH Voltage	1.7		$V_{CC} + 0.3$	V	LVC MOS
V_{IL}	Input LOW Voltage	-0.3		0.7	V	LVC MOS
V_{PP}	Peak-to-peak input voltage ¹ PECL_CLK, PECL_CLK	500		1000	mV	LVPECL
V_{CMR}	Common Mode Range ¹ PECL_CLK, PECL_CLK	1.2		$V_{CC} - 0.7$	V	LVPECL
V_{OH}	Output HIGH Voltage	1.8			V	$I_{OH} = -15mA^2$
V_{OL}	Output LOW Voltage			0.6	V	$I_{OL} = 15mA^2$
Z_{OUT}	Output Impedance		18	26	Ω	
I_{IN}	Input Current			± 120	mA	
C_{IN}	Input Capacitance		4.0		pF	
C_{PD}	Power Dissipation Capacitance		8.0	10	pF	Per Output
I_{CCA}	Maximum PLL Supply Current		2.0	5.0	mA	V_{CCA} Pin
I_{CC}	Maximum Quiescent Supply Current				mA	All V_{CC} Pins
V_{TT}	Output Termination Voltage		$V_{CC} \pm 2$		V	

Notes:

1. Exceeding the specified V_{CMR}/V_{PP} window results in a t_{PD} changes of < 250 pS.
2. The ASM51961P is capable of driving 50Ω transmission lines on the incident edge. Each output drives one 50Ω parallel terminated transmission line to a termination voltage of V_{TT} . Alternatively, the device drives up two 50Ω series terminated transmission lines.



rev 0.2

Table 7: AC Characteristics ($V_{CC} = 2.5V \pm 5\%$, $T_A = -40^\circ C$ to $+85^\circ C$)¹

Symbol	Characteristic		Min	Typ	Max	Unit	Condition
f_{ref}	Input Frequency	F_RANGE = 0 F_RANGE = 1	100 50		200 100	MHz	
f_{max}	Maximum Output Frequency	F_RANGE = 0 F_RANGE = 1	100 50		200 100	MHz	
f_{refDC}	Reference Input Duty Cycle		25		75	%	
$t_{(\phi)}$	Propagation Delay ² (static phase offset)	PECL_CLK to FB_IN	-50		175	pS	PLL locked
$t_{sk(O)}$	Output-to-Output Skew ³			90	150	pS	
DC _O	Output Duty Cycle	F_RANGE = 0 F_RANGE = 1	40 45	50 50	60 55	%	
t_r, t_f	Output Rise/Fall Time		0.1		1.0	nS	0.6 to 1.8V
$t_{PLZ,HZ}$	Output Disable Time				10	nS	
$t_{PZL,LZ}$	Output Enable Time				10	nS	
$t_{JIT(CC)}$	Cycle-to-Cycle Jitter	RMS (1σ) ⁴			15	pS	
$t_{JIT(PER)}$	Period Jitter	RMS (1σ)		7.0	10	pS	
$t_{JIT(\phi)}$	I/O Phase Jitter	RMS (1σ) F_RANGE = 0 F_RANGE = 1			$0.0015 \cdot T$ $0.0010 \cdot T$	nS	T = Clock Signal Period
t_{lock}	Maximum PLL Lock Time				10	mS	

Notes:

- AC characteristics apply for parallel output termination of 50Ω to V_{TT} .
- t_{PD} applies for $V_{CMR} = V_{CC} - 1.3V$ and $V_{PP} = 800mV$
- See applications section for part-to-part skew calculation
- See applications section for calculation for other confidence factors than 1σ



APPLICATIONS INFORMATION

Power Supply Filtering

The ASM51961P is a mixed analog/digital product and as such it exhibits some sensitivities that would not necessarily be seen on a fully digital product. Analog circuitry is naturally susceptible to random noise, especially if this noise is seen on the power supply pins. The ASM51961P provides separate power supplies for the output buffers (V_{CC}) and the phase-locked loop (V_{CCA}) of the device. The purpose of this design technique is to isolate the high switching noise digital outputs from the relatively sensitive internal analog phase-locked loop. In a controlled environment such as an evaluation board this level of isolation is sufficient. However, in a digital system environment where it is more difficult to minimize noise on the power supplies a second level of isolation may be required. The simplest form of isolation is power supply filter on the V_{CCA} pin for the ASM51961P.

Figure 3. illustrates a typical power supply filter scheme. The ASM51961P is most susceptible to noise with spectral content in the 10KHz to 5MHz range. Therefore the filter should be designed to target this range. The key parameter that needs to be met in the final filter design is the DC voltage drop that will be seen between the V_{CC} supply and the V_{CCA} pin of the ASM51961P. From the data sheet the I_{CCA} current (the current sourced through the V_{CCA} pin) is typically 2mA (5mA maximum), assuming that a minimum of 2.375V ($V_{CC} = 3.3V$ or $V_{CC} = 2.5V$) must be maintained on the V_{CCA} pin. The resistor R_F shown in Figure 3. must have a resistance of 270 ($V_{CC} = 3.3V$) or 5 to 15 ($V_{CC} = 2.5V$) to meet the voltage drop criteria. The RC filter pictured will provide a broadband filter with approximately 100:1 attenuation for noise whose spectral content is above 20KHz. As the noise frequency crosses the series resonant point of an individual capacitor it's overall impedance begins to look inductive and thus increases with increasing frequency. The parallel capacitor combination shown ensures that a low impedance path to ground exists for frequencies well above the bandwidth of the PLL.

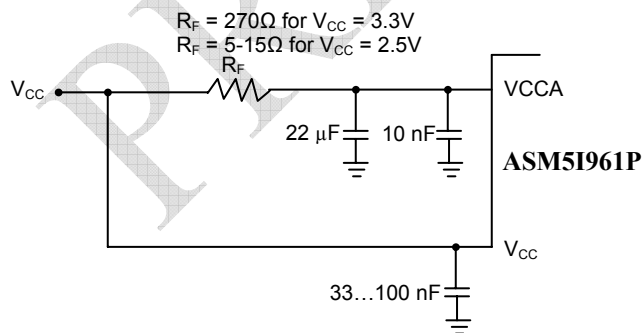

Figure 3. Power Supply Filter

Although the ASM51961P has several design features to minimize the susceptibility to power supply noise (isolated power and grounds and fully differential PLL) there still may be applications in which overall performance is being degraded due to system power supply noise. The power supply filter schemes discussed in this section should be adequate to eliminate power supply noise related problems in most designs.

Driving Transmission Lines

The ASM51961P clock driver was designed to drive high speed signals in a terminated transmission line environment. To provide the optimum flexibility to the user the output drivers were designed to exhibit the lowest impedance possible. With an output impedance of less than 15Ω the drivers can drive either parallel or series terminated transmission lines. In most high performance clock networks point to point distribution of signals is the method of choice. In a point to point scheme either series terminated or parallel terminated transmission lines can be used. The parallel technique terminates the signal at the end of the line with a 50Ω resistance to $V_{CC}/2$. This technique draws a fairly high level of DC current and thus only a single terminated line can be driven by each output of the ASM51961P clock driver. For the series terminated case however there is no DC current draw, thus the outputs can drive multiple series terminated lines. Figure 4. illustrates an output driving a single series terminated line vs two series terminated lines in parallel. When taken to its extreme the fanout of the ASM51961P clock driver is effectively doubled due to its capability to drive multiple lines.

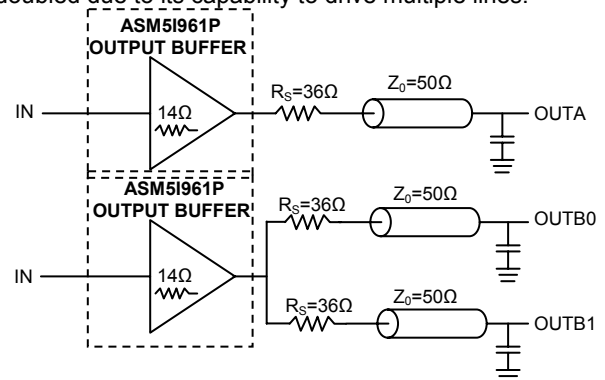

Figure 4. Single versus Dual Transmission Lines

The waveform plots of Figure 5. show the simulation results of an output driving a single line vs two lines. In both cases the drive capability of the ASM51961P output buffer is more than sufficient to drive 50Ω transmission lines on the incident edge. Note from the delay measurements in the simulations a delta of only 43ps exists between the two differently loaded outputs. This suggests that the dual line driving need not be used exclusively to maintain the tight output-to-output skew of the ASM51961P. The output waveform in Figure 5. shows



rev 0.2

a step in the waveform, this step is caused by the impedance mismatch seen looking into the driver. The parallel combination of the 36Ω series resistor plus the output impedance does not match the parallel combination of the line impedances. The voltage wave launched down the two lines will equal:

$$V_L = V_S (Z_o / (R_s + R_o + Z_o))$$

$$Z_o = 50\Omega \parallel 50\Omega$$

$$R_s = 36\Omega \parallel 36\Omega$$

$$R_o = 14\Omega$$

$$V_L = 3.0 (25 / (18 + 14 + 25)) = 3.0 (25 / 57)$$

$$= 1.31V$$

At the load end the voltage will double, due to the near unity reflection coefficient, to 2.62V. It will then increment towards the quiescent 3.0V in steps separated by one round trip delay (in this case 4.0nS).

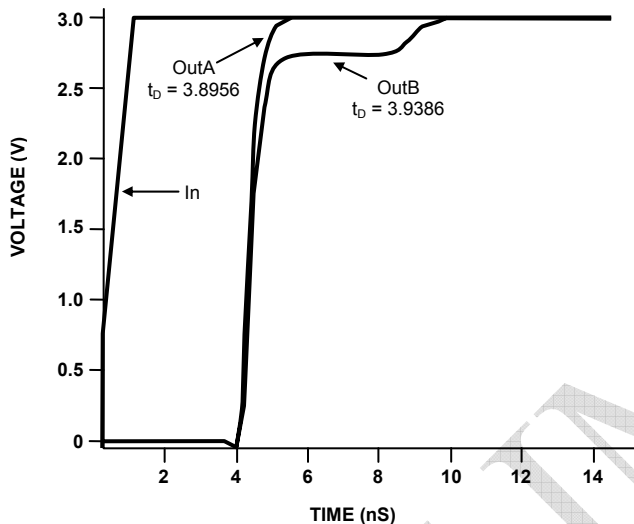

Figure 5. Single versus Dual Waveforms

Since this step is well above the threshold region it will not cause any false clock triggering, however designers may be uncomfortable with unwanted reflections on the line. To better match the impedances when driving multiple lines the situation in Figure 6. should be used. In this case the series terminating resistors are reduced such that when the parallel combination is added to the output buffer impedance the line impedance is perfectly matched.

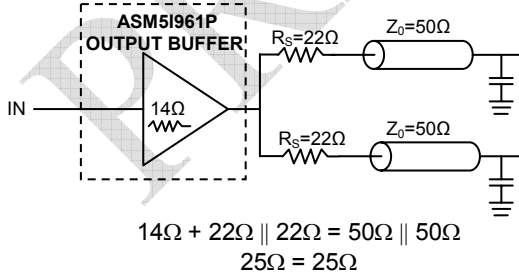

Figure 6. Optimized Dual Line Termination

Using the ASM51961P in zero-delay applications

Nested clock trees are typical applications for the ASM51961P. Designs using the ASM51961P, as LVCMOS PLL fanout buffer with zero insertion delay will show significantly lower clock skew than clock distributions developed from CMOS fanout buffers. The external feedback option of the ASM51961P clock driver allows for its use as a zero delay buffer. By using the QFB output as a feedback to the PLL the propagation delay through the device is virtually eliminated. The PLL aligns the feedback clock output edge with the clock input reference edge resulting a near zero delay through the device. The maximum insertion delay of the device in zero-delay applications is measured between the reference clock input and any output. This effective delay consists of the static phase offset, I/O jitter (phase or long-term jitter), feedback path delay and the output-to-output skew error relative to the feedback output.

Calculation of part-to-part skew

The ASM51961P zero delay buffer supports applications where critical clock signal timing can be maintained across several devices. If the reference clock inputs of two or more ASM51961P are connected together, the maximum overall timing uncertainty from the common PCLK input to any output is:

$$t_{SK(PP)} = t_{(\phi)} + t_{SK(O)} + t_{PD, LINE(FB)} + t_{JIT(\phi)} \cdot CF$$

This maximum timing uncertainty consist of 4 components: static phase offset, output skew, feedback board trace delay and I/O (phase) jitter:

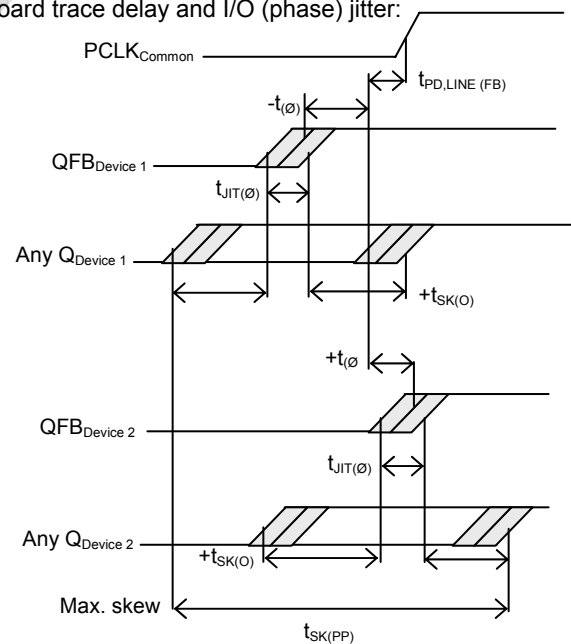

Figure 7. ASM51961P max. device-to-device skew

Due to the statistical nature of I/O jitter a rms value (1σ) is specified. I/O jitter numbers for other confidence factors (CF) can be derived from Table 8.



rev 0.2

Table 8: Confidence Factor CF

CF	Probability of clock edge within the distribution
± 1σ	0.68268948
± 2σ	0.95449988
± 3σ	0.99730007
± 4σ	0.99993663
± 5σ	0.99999943
± 6σ	0.99999999

The feedback trace delay is determined by the board layout and can be used to fine-tune the effective delay through each device. In the following example calculation a I/O jitter confidence factor of 99.7% (± 3 σ) is assumed, resulting in a worst case timing uncertainty from input to any output of -236pS to 361pS relative to PCLK (f=125 MHz, V_{CC}=2.5V):

$$t_{SK(PP)} = [-50ps...175ps] + [-150ps...150ps] + [(12ps * -3)...(12ps * 3)] + t_{PD, LINE(FB)}$$

$$t_{SK(PP)} = [-236ps...361ps] + t_{PD, LINE(FB)}$$

Due to the frequency dependence of the I/O jitter, Figure 8. "Max. I/O Jitter versus frequency" can be used for a more precise timing performance analysis.

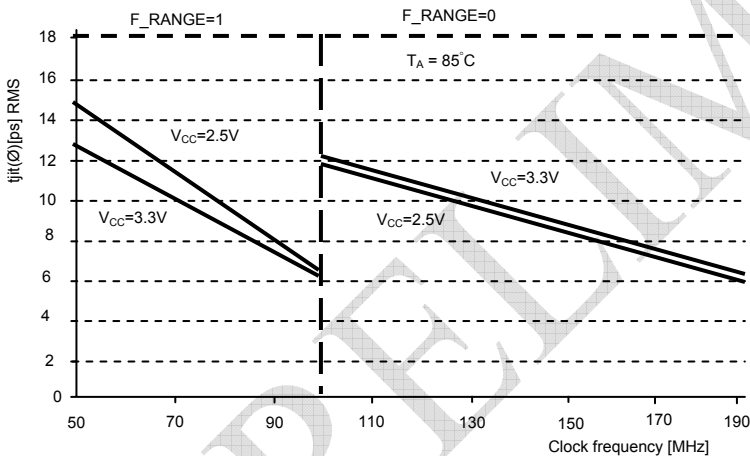

Figure 8. Max. I/O Jitter versus frequency

Power Consumption of the ASM5I961P and Thermal Management

The ASM5I961P AC specification is guaranteed for the entire operating frequency range up to 200 MHz. The ASM5I961P power consumption and the associated long-term reliability may decrease the maximum frequency limit, depending on operating conditions such as clock frequency, supply voltage, output loading, ambient temperature, vertical convection and thermal conductivity of package and board. This section describes the impact of these parameters on the junction temperature and gives a guideline to estimate the ASM5I961P die junction temperature and the associated device reliability.

Table 9: Die junction temperature and MTBF

Junction temperature (°C)	MTBF (Years)
100	20.4
110	9.1
120	4.2
130	2.0

Increased power consumption will increase the die junction temperature and impact the device reliability (MTBF). According to the system-defined tolerable MTBF, the die junction temperature of the ASM5I961P needs to be controlled and the thermal impedance of the board/package should be optimized. The power dissipated in the ASM5I961P is represented in equation 1. Where I_{CCQ} is the static current consumption of the ASM5I961P, CPD is the power dissipation capacitance per output, (M)ΣC_L represents the external capacitive output load, N is the number of active outputs (N is always 27 in case of the ASM5I961P). The ASM5I961P supports driving transmission lines to maintain high signal integrity and tight timing parameters. Any transmission line will hide the lumped capacitive load at the end of the board trace, therefore, ΣC_L is zero for controlled transmission line systems and can be eliminated from equation 1. Using parallel termination output termination results in equation 2 for power dissipation. In equation 2, P stands for the number of outputs with a parallel or thevenin termination, V_{OL}, I_{OL}, V_{OH} and I_{OH} are a function of the output termination technique and DCQ is the clock signal duty cycle. If transmission lines are used ΣC_L is zero in equation 2 and can be eliminated. In general, the use of controlled transmission line techniques eliminates the impact of the lumped capacitive loads at the end lines and greatly reduces the power dissipation of the device. Equation 3 describes the die junction temperature T_J as a function of the power consumption.



rev 0.2

$$P_{TOT} = \left[I_{CCQ} + V_{CC} \cdot f_{CLOCK} \cdot \left(N \cdot C_{PD} + \sum_M C_L \right) \right] \cdot V_{CC} \quad \text{Equation 1}$$

$$P_{TOT} = V_{CC} \cdot \left[I_{CCQ} + V_{CC} \cdot f_{CLOCK} \cdot \left(N \cdot C_{PD} + \sum_M C_L \right) \right] + \sum_P \left[DC_Q \cdot I_{OH} (V_{CC} - V_{OH}) + (1 - DC_Q) \cdot I_{OL} \cdot V_{OL} \right] \quad \text{Equation 2}$$

$$T_J = T_A + P_{TOT} \cdot R_{thja} \quad \text{Equation 3}$$

$$f_{CLOCKMAX} = \frac{1}{C_{PD} \cdot N \cdot V_{CC}^2} \cdot \left[\frac{T_{JMAX} - T_A}{R_{thja}} - (I_{CCQ} \cdot V_{CC}) \right] \quad \text{Equation 4}$$

www.DataSheet4U.com

Where R_{thja} is the thermal impedance of the package (junction to ambient) and T_A is the ambient temperature. According to Table 9, the junction temperature can be used to estimate the long-term device reliability. Further, combining equation 1 and equation 2 results in a maximum operating frequency for the ASM51961P in a series terminated transmission line system.

Table 10: Thermal package impedance of the 32LQFP

Convection, LFPM	R_{thja} (1P2S board), K/W
Still air	80
100 lfpm	70
200 lfpm	61
300 lfpm	57
400 lfpm	56
500 lfpm	55

$T_{J,MAX}$ should be selected according to the MTBF system requirements and Table 9. R_{thja} can be derived from Table 10. The R_{thja} represent data based on 1S2P

boards, using 2S2P boards will result in a lower thermal impedance than indicated below. If the calculated maximum frequency is below 200 MHz, it becomes the upper clock speed limit for the given application conditions. The following two derating charts describe the safe frequency operation range for the ASM51961P. The charts were calculated for a maximum tolerable die junction temperature of 110°C, corresponding to an estimated MTBF of 9.1 years, a supply voltage of 3.3V and series terminated transmission line or capacitive loading. Depending on a given set of these operating conditions and the available device convection a decision on the maximum operating frequency can be made. There are no operating frequency limitations if a 2.5V power supply or the system specifications allow for a MTBF of 4 years (corresponding to a max. junction temperature of 120°C).



rev 0.2

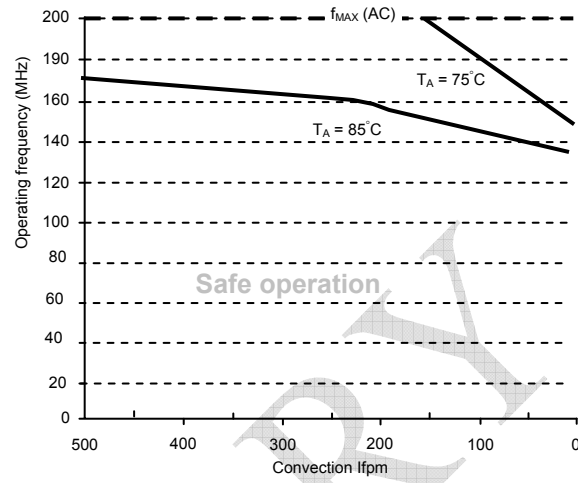
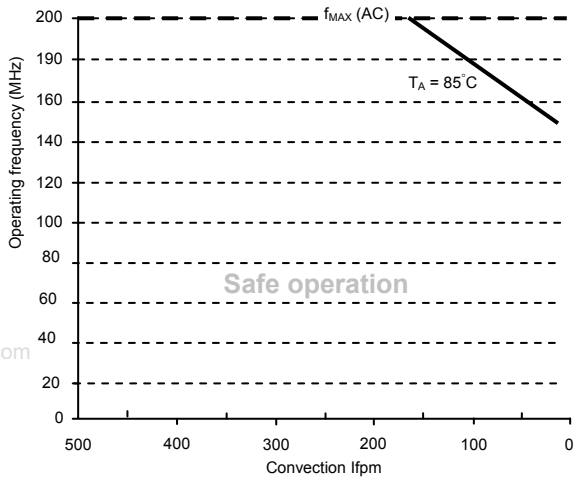

Figure 9. Maximum ASM5I961P frequency, $V_{CC} = 3.3V$, MTBF 9.1 years, driving series terminated transmission lines

Figure 10. Maximum ASM5I961P frequency, $V_{CC} = 3.3V$, MTBF 9.1 years, 4pF load per line

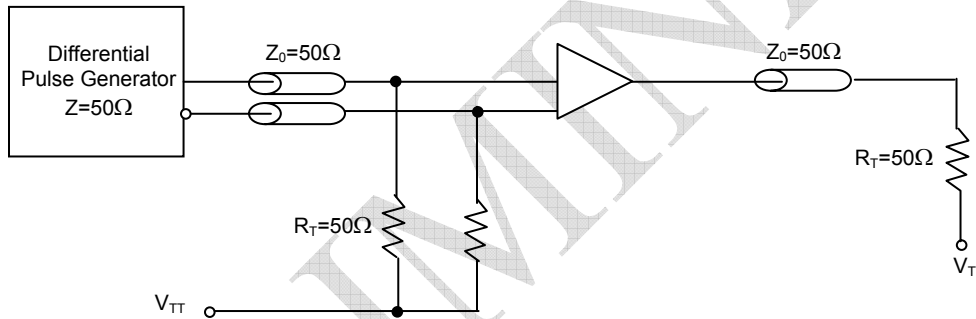

Figure 11. TCLK ASM5I961P AC test reference for $V_{CC} = 3.3V$ and $V_{CC} = 2.5V$



rev 0.2

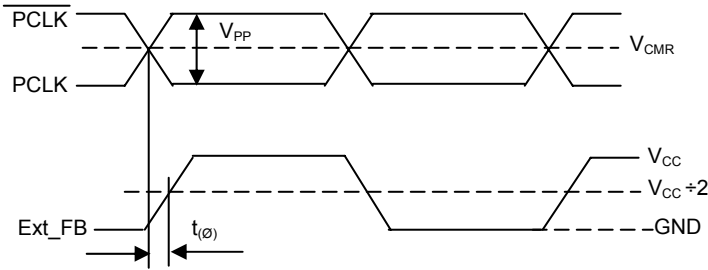

Figure 12. Propagation Delay (t_{ϕ}). Static phase offset test reference

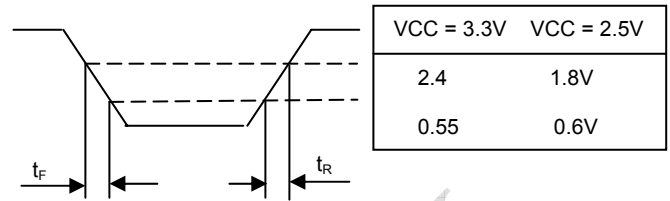
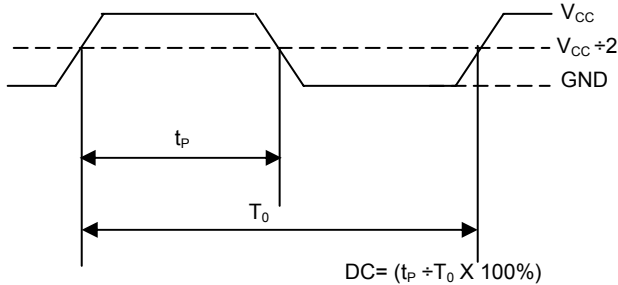
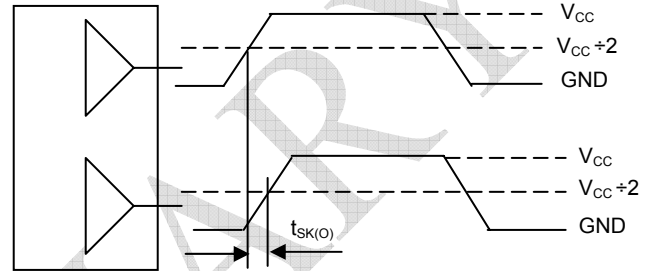

Figure 13. Output Transition Time Test Reference



The time from the PLL controlled edge to the non-controlled edge, divided by the time between PLL controlled edges, expressed as a percentage.

Figure 14. Output Duty Cycle (DC)



The pin-to-pin skew is defined as the worst case difference in propagation delay between any similar delay path within a single device

Figure 15. Output-to-Output Skew $t_{SK(O)}$

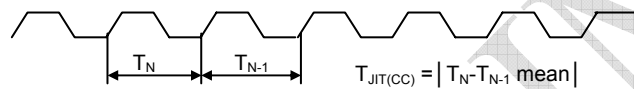

The variation in cycle time of a signal between adjacent cycles, over a random sample of adjacent cycle pairs

Figure 16. Cycle-to-cycle Jitter

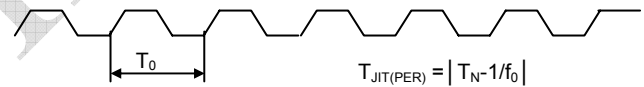

The deviation in cycle time of a signal with respect to the ideal period over a random sample of cycles

Figure 17. Period Jitter

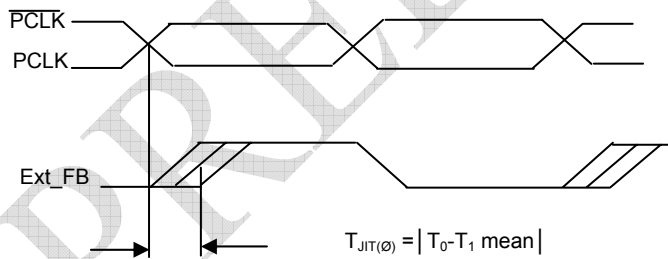

The deviation in t_0 for a controlled edge with respect to a t_0 mean in a random sample of cycles

Figure 18. I/O Jitter



rev 0.2

Package Information

32-lead LQFP Package

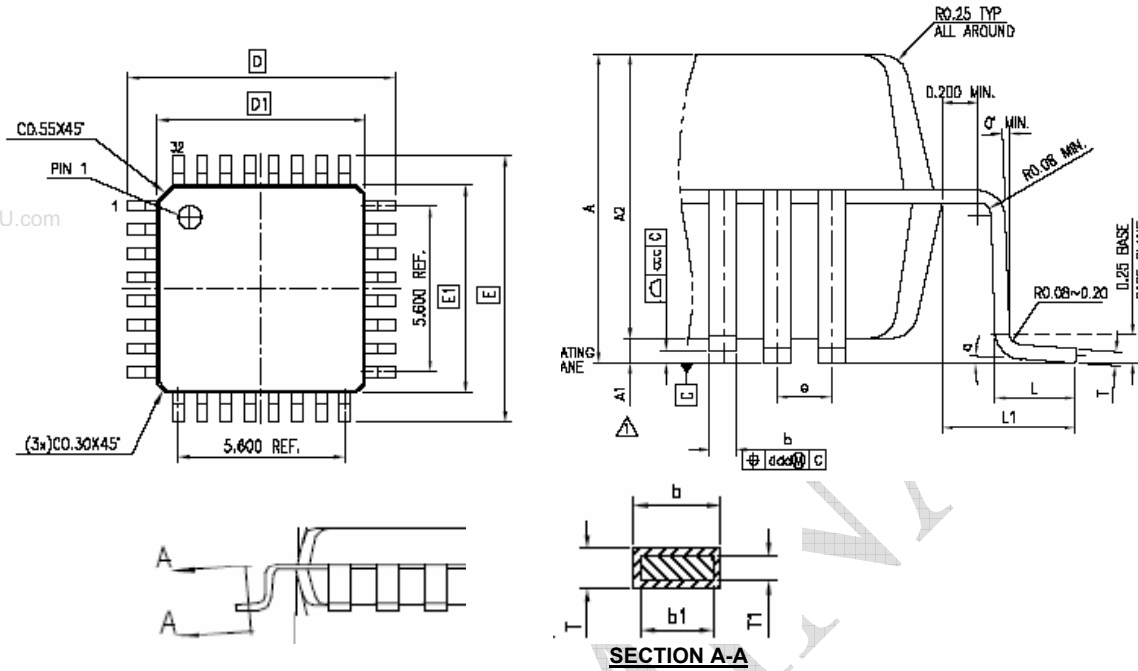

Symbol	Dimensions			
	Inches		Millimeters	
	Min	Max	Min	Max
A	0.0630	...	1.6
A1	0.0020	0.0059	0.05	0.15
A2	0.0531	0.0571	1.35	1.45
D	0.3465	0.3622	8.8	9.2
D1	0.2717	0.2795	6.9	7.1
E	0.3465	0.3622	8.8	9.2
E1	0.2717	0.2795	6.9	7.1
L	0.0177	0.0295	0.45	0.75
L1	0.03937 REF		1.00 REF	
T	0.0035	0.0079	0.09	0.2
T1	0.0038	0.0062	0.097	0.157
b	0.0118	0.0177	0.30	0.45
b1	0.0118	0.0157	0.30	0.40
R0	0.0031	0.0079	0.08	0.20
e	0.031 BASE		0.8 BASE	
a	0°	7°	0°	7°



rev 0.2

Ordering Information

Part Number	Marking	Package Type	Temperature
ASM5I961P-32LR	ASM5I961P	32 pin LQFP	Industrial
ASM5I961P-32LR	ASM5I961P	32 pin LQFP – Tape and Reel	Industrial
ASM5I961PG-32LR	ASM5I961PG	32 pin LQFP, Green	Industrial
ASM5I961PG-32LR	ASM5I961PG	32 pin LQFP – Tape and Reel, Green	Industrial

Device Ordering Information

A S M 5 I 9 6 1 P F - 3 2 - L R

R = Tape & reel, T = Tube or Tray

O = SOT	U = MSOP
S = SOIC	E = TQFP
T = TSSOP	L = LQFP
A = SSOP	U = MSOP
V = TVSOP	P = PDIP
B = BGA	D = QSOP
Q = QFN	X = SC-70

DEVICE PIN COUNT

F = LEAD FREE AND RoHS COMPLIANT PART
G = GREEN PACKAGE

PART NUMBER

X= Automotive (-40C to +125C)	I= Industrial (-40C to +85C)	P or n/c = Commercial (0C to +70C)
-------------------------------	------------------------------	------------------------------------

1 = Reserved	6 = Power Management
2 = Non PLL based	7 = Power Management
3 = EMI Reduction	8 = Power Management
4 = DDR support products	9 = Hi Performance
5 = STD Zero Delay Buffer	0 = Reserved

ALLIANCE SEMICONDUCTOR MIXED SIGNAL PRODUCT

Licensed under US patent #5,488,627, #6,646,463 and #5,631,920.



Alliance Semiconductor Corporation
2575 Augustine Drive,
Santa Clara, CA 95054
Tel# 408-855-4900
Fax: 408-855-4999
www.alsc.com

Copyright © Alliance Semiconductor
All Rights Reserved
Part Number: ASM5I961P
Document Version: 0.2

Note: This product utilizes US Patent # 6,646,463 Impedance Emulator Patent issued to Alliance Semiconductor, dated 11-11-2003

© Copyright 2003 Alliance Semiconductor Corporation. All rights reserved. Our three-point logo, our name and Intelliwatt are trademarks or registered trademarks of Alliance. All other brand and product names may be the trademarks of their respective companies. Alliance reserves the right to make changes to this document and its products at any time without notice. Alliance assumes no responsibility for any errors that may appear in this document. The data contained herein represents Alliance's best data and/or estimates at the time of issuance. Alliance reserves the right to change or correct this data at any time, without notice. If the product described herein is under development, significant changes to these specifications are possible. The information in this product data sheet is intended to be general descriptive information for potential customers and users, and is not intended to operate as, or provide, any guarantee or warranty to any user or customer. Alliance does not assume any responsibility or liability arising out of the application or use of any product described herein, and disclaims any express or implied warranties related to the sale and/or use of Alliance products including liability or warranties related to fitness for a particular purpose, merchantability, or infringement of any intellectual property rights, except as express agreed to in Alliance's Terms and Conditions of Sale (which are available from Alliance). All sales of Alliance products are made exclusively according to Alliance's Terms and Conditions of Sale. The purchase of products from Alliance does not convey a license under any patent rights, copyrights; mask works rights, trademarks, or any other intellectual property rights of Alliance or third parties. Alliance does not authorize its products for use as critical components in life-supporting systems where a malfunction or failure may reasonably be expected to result in significant injury to the user, and the inclusion of Alliance products in such life-supporting systems implies that the manufacturer assumes all risk of such use and agrees to indemnify Alliance against all claims arising from such use.