



ASM8412CA □
DATA SHEET

6F-3 NO.7, LANE 75, TA-AN ROAD, SEC.1, TAIPEI, TAIWAN, R.O.C.
台北市大安路一段75巷7號6F-3 TEL:886-2-27818277 FAX:886-2-27815779

<http://www.aplusinc.com.tw>

ASM8412CA – VERY LOW-COST VOICE SYNTHESIZER WITH 4-BIT MICROPROCESSOR

1.0 General Description

The ASM8412CA is very low cost voice synthesizer with 4-bit microprocessor. It has various features including 4-bit ALU, ROM, RAM, I/O ports, timers, clock generator, watchdog timer(WDT), voice synthesizer, etc. It consists of 22 instructions in the device. With CMOS technology and halt function can minimize power dissipation. Its architecture is similar to RISC, with two stages of instruction pipeline. It allows all instructions to be executed in a single cycle, except for program branches and data table read instructions (which need two instruction cycles).

1.1 Feature

- ◆ Single power supply can operate from 2.4V through 5V
- ◆ Internal Program ROM: 4K x 10-bit
- ◆ 1 sets of 18-bit DPR can access up to 256K x 10 bits data memory space
- ◆ Data Registers:
 - 96 x 4-bit data RAM (00-1Fh plus 40h-7Fh)
 - Unbanked special function registers (SFR) range: 20h-3Fh
- ◆ I/O Ports:
 - PRA: 4-bit I/O Port A (2Bh)
 - PRB: 4-bit Output Port B (2Dh)
 - PRC: 4-bit Input Port C (2Fh)
- ◆ On-chip clock generator: Resistive Clock Drive (*RM*)
- ◆ Timer: 1
 - Timer0: a 9-bit auto-reload timer/counter
- ◆ Stack: 2-level subroutine nesting
- ◆ HALT and Release from HALT function to reduce power consumption
- ◆ Watch Dog Timer (*WDT*)
- ◆ Instruction: 1-cycle instruction except for table read and program branches which are 2-cycles
- ◆ Number of instruction: 22

FIGURE 1.1 : Block Diagram of ASM8412CA

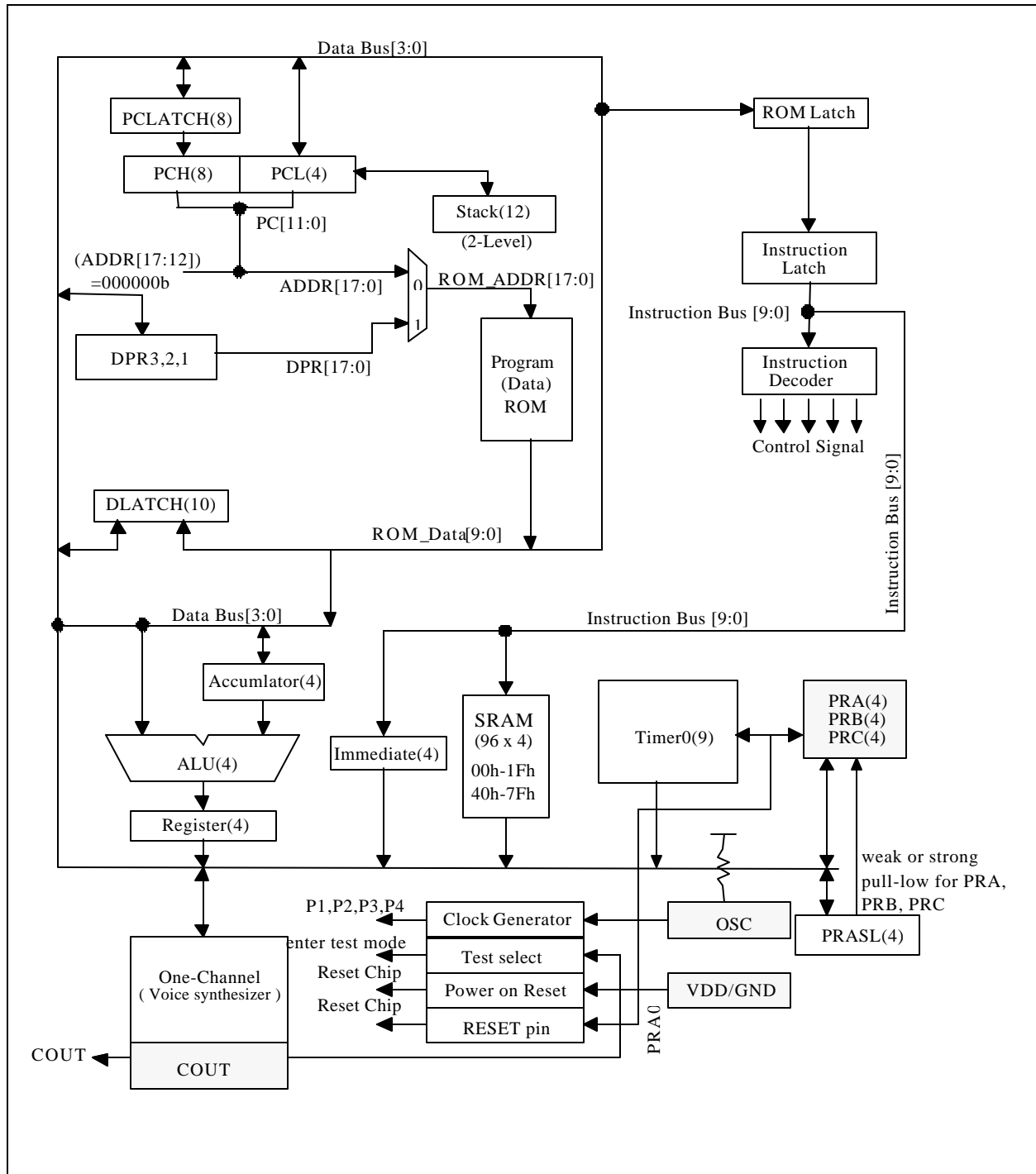
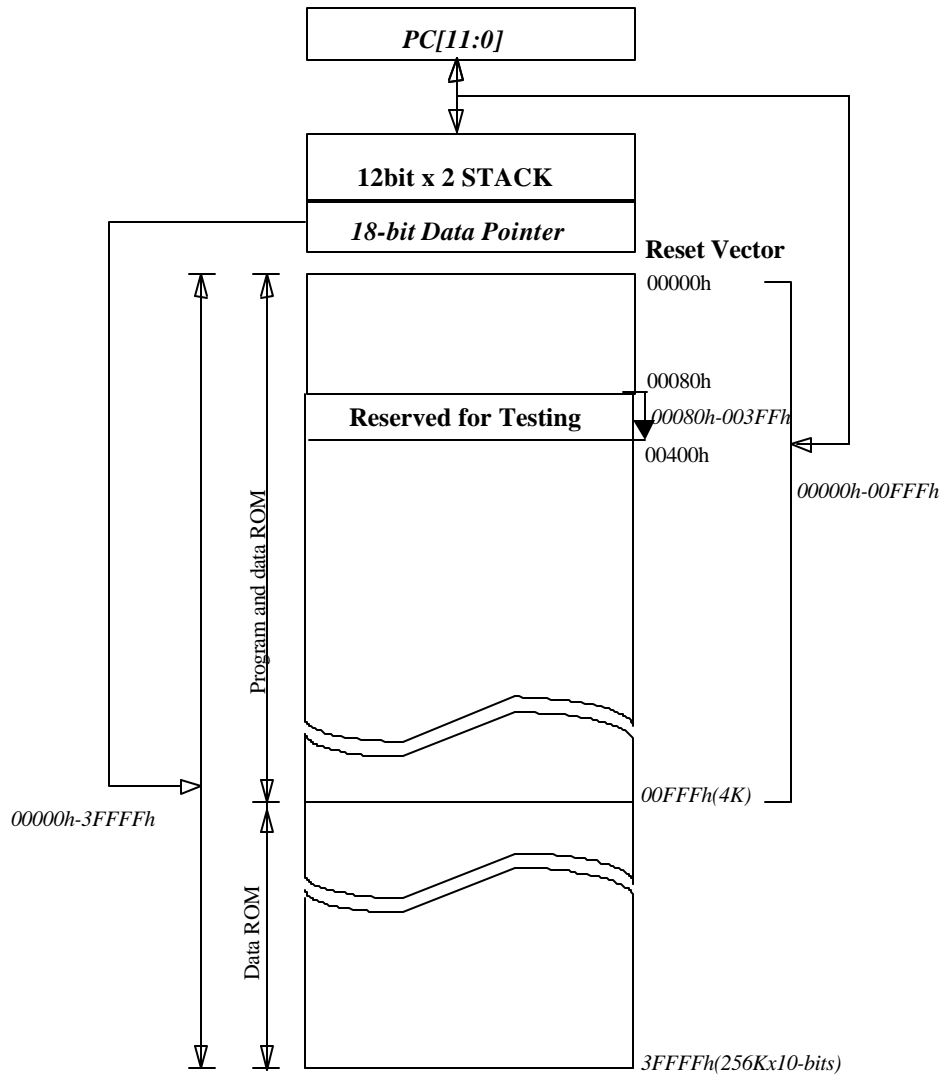

FIGURE 1.2 : External ROM Map of ASM8412CA



1.2 Pin-Out

ASM8412CA Pin-Out			
PRC1	I	STI Std./O.D.	Input port with programmable strong pull-low or weak pull-low or fix-input-floating capability
PRC0/RESET	I	STI Std./O.D.	Input port with programmable strong pull-low or weak pull-low or fix-input-floating capability <i>Mask option selected as an external RESET pin with weak pull-low capability</i>
PRA3-1	I/O	STI Std./O.D.	I/O port with programmable strong pull-low or weak pull-low or fix-input-floating capability Output type with standard or Open-Drain output
PRA0/RESET	I/O	STI Std./O.D.	I/O port with programmable strong pull-low or weak pull-low or fix-input-floating capability Output type with standard or Open-Drain output <i>Mask option selected as an external RESET pin with weak pull-low capability</i>
OSC	I	-	RM mode Oscillator input
VDD1	I	-	First Power supply during operation
COUT	O	-	Current Output of Audio
GND1	I	-	First Circuit Ground Potential
GND2	I	-	Second Circuit Ground Potential
TEST	O	-	Enter Test Mode. (TEST = High)
VDD2	I	-	Second Power supply during operation
PRB0-3	O	Std./O.D.	Output type with standard or Open-Drain output
PRC2-3	I	STI Std./O.D.	Input port with programmable strong pull-low or weak pull-low or fix-input-floating capability

1.3 Application circuit

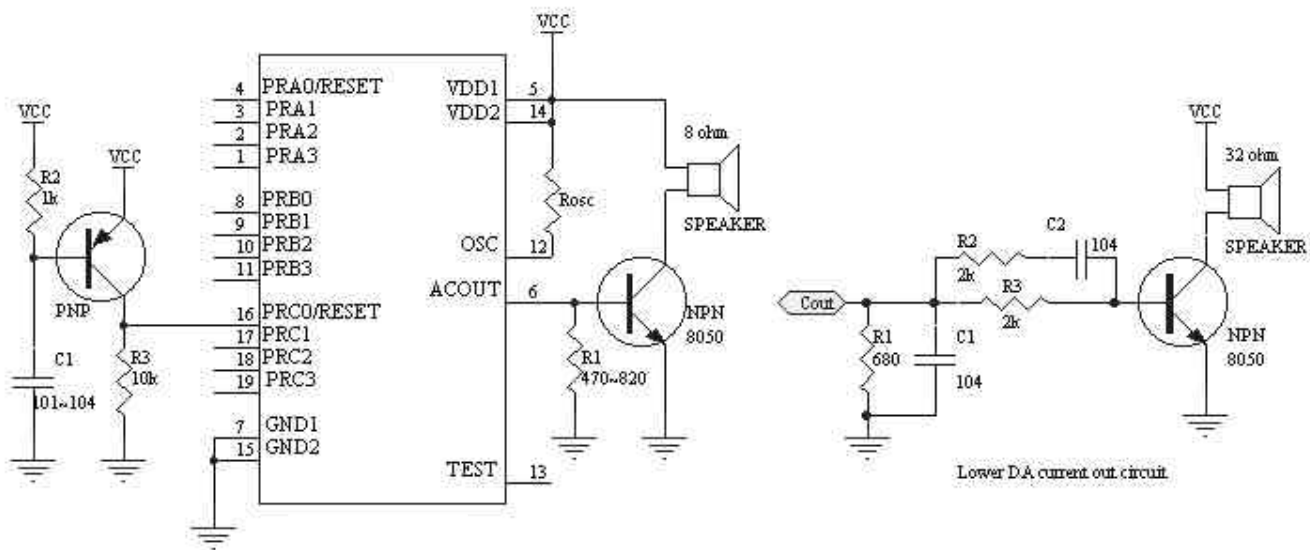

1.4 Bonding Diagram

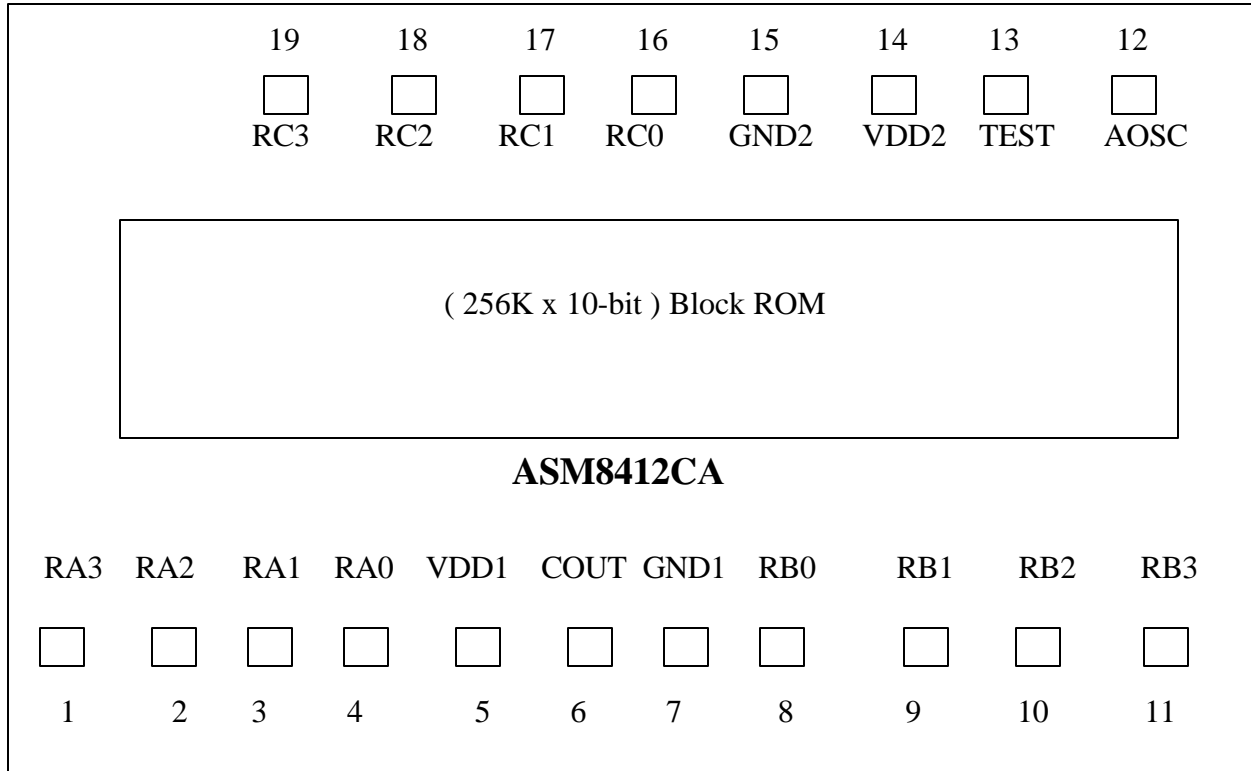

ASM8412CA Pad Location				Chip Size: X=1540+100 (um), Y=3390+100 (um)			
PAD #	PAD Name	X	Y	PAD #	PAD Name	X	Y
1	RA3	-682.16	-1575.24	11	RB3	667.68	-1575.24
2	RA2	-559.84	-1575.24	12	AOSC	633.56	1606.56
3	RA1	-437.52	-1575.24	13	TEST	432.48	1606.56
4	RA0	-315.2	-1575.24	14	VDD2	273.16	1606.56
5	VDD1	-191.28	-1575.24	15	GND2	134.68	1606.56
6	COUT	71.12	-1575.24	16	RC0	-51.76	1606.56
7	GND1	189.52	-1575.24	17	RC1	-248.4	1606.56
8	RB0	307.92	-1575.24	18	RC2	-454.24	1606.56
9	RB1	430.24	-1575.24	19	RC3	-650.88	1606.56
10	RB2	552.56	-1575.24				

1.5 DC Characteristics for ASM8412CA

SYMBOL	PARAMETER		VDD	MIN.	TYP.	MAX.	UNIT	CONDITION
VDD	OPERATING VOLTAGE			2.4	3	5	V	depending on Freq.
Isb	SUPPLY CURRENT	STANDBY	3			1	uA	4MHz, RM in HALT Mode
			5			1		
Iop	T	OPERATING	3		2		mA	4MHz, RM IO Floating
			5		7			
Iih	INPUT CURRENT /Internal pull low		3		3		uA	4MHz, RM in HALT Mode (IO Ports with weak pull-high pull-low)
			5		9			
			5		-5.2			
Ioh	OUTPUT HIGH CURRENT		3		-3		mA	4MHz, RM (IO ports)
			5		-8			
Iol	OUTPUT LOW CURRENT		3		7		mA	4MHz, RM (IO ports)
			5		20			
dF/F	FREQUENCY STABILITY			-10		10	%	$\frac{F_{osc}(3v)-F_{osc}(2.4v)}{F_{osc}(3v)}$
dF/F	Fosc VARIATION			-20		20	%	VDD=3V, Rosc=220k, 4MHz

FIGURE 1.3 : Frequency Range for Rosc in RM mode

Resistor(k ohm)	330	220	200	150
3v Freq.(MHz)	2.62	3.90	4.37	5.74

