

REVISION L

DO NOT SCALE FROM THIS PRINT

- NOTES:
 1. **VITA 57 CONNECTOR.**
 2. $\text{\textcircled{C}}$ REPRESENTS A CRITICAL DIMENSION.
 3. MINIMUM PUSHOUT FORCE: 0.50 LBS.
 4. PARTS TO BE PACKAGED IN TAPE & REEL.
 5. DIMENSION C12 MUST BE MEASURED IN THE FOUR OUTSIDE CORNERS USING INSPECTION FIXTURE AT-1817-836-2, USE CO-AU-WI-2003-M FOR PROCESS.
 6. MAXIMUM ROW TO ROW VARIATION .003[0.08], MEASURED FIRST & LAST POSITIONS ONLY, ALL ROWS.
 7. NOTE DELETED.
 8. SOLDER CHARGE VOLUME IS .00000891 CUBIC INCHES (REF).

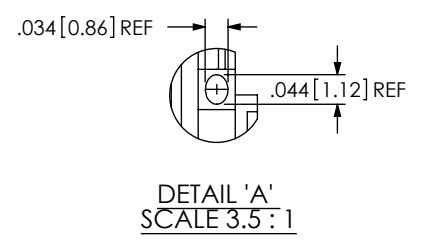
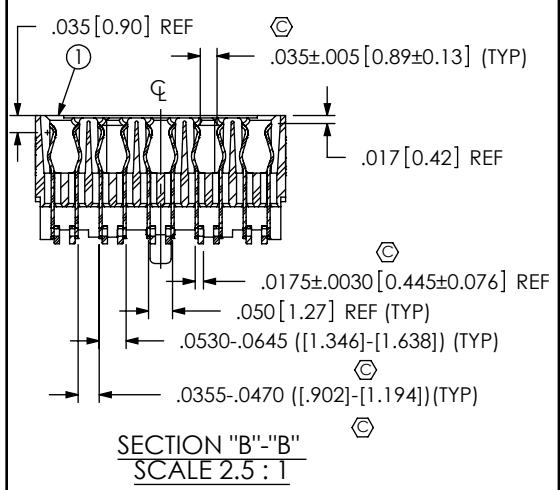
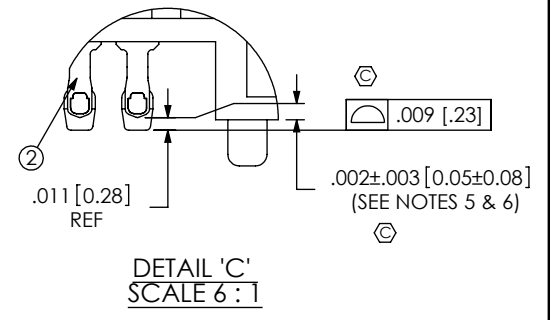
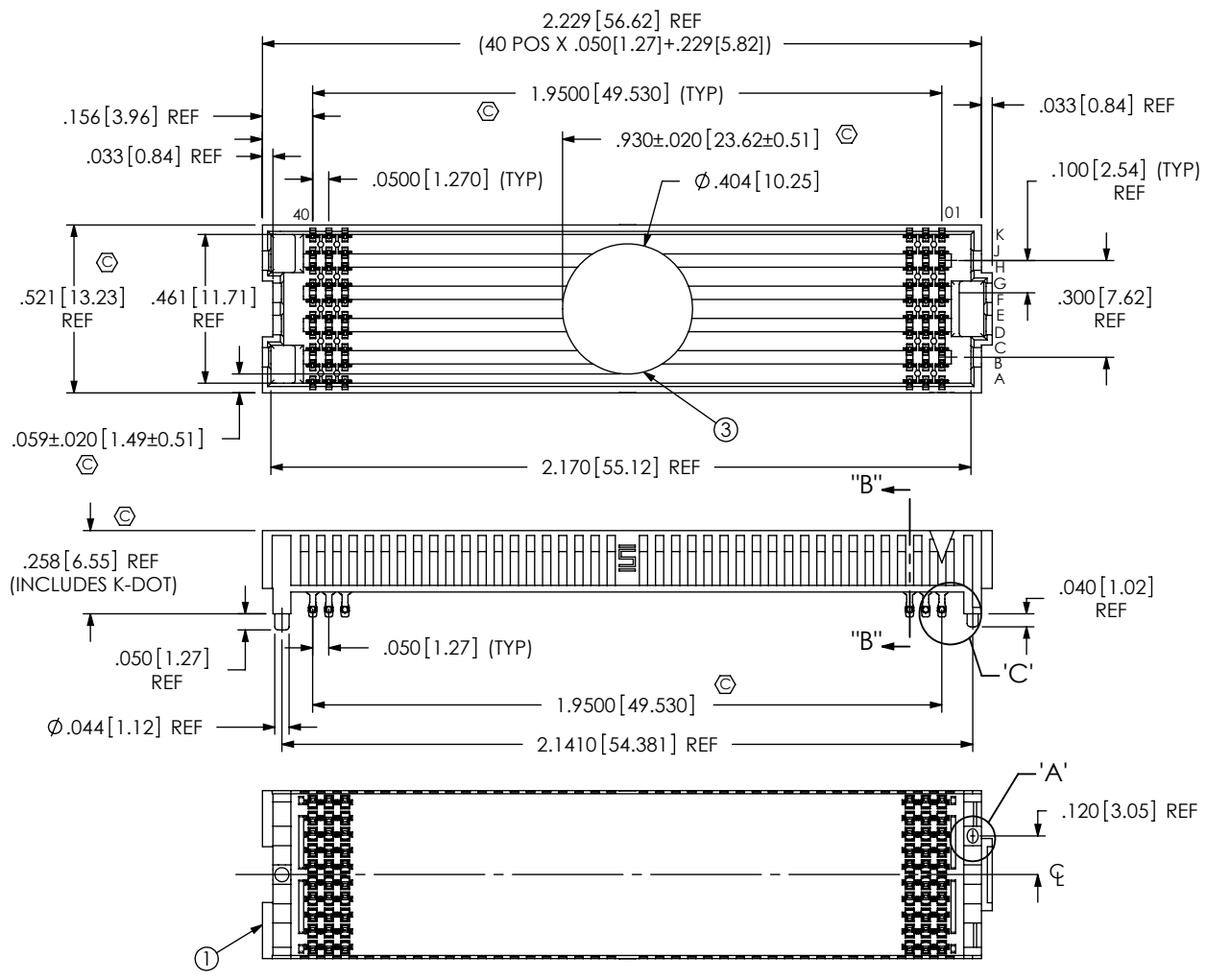

ITEM NO.	PART NUMBER	QUANTITY	MATERIAL
1	SEAF-40-06.5-10-A	1.0000	LCP, UL 94 V0, COLOR: BLACK
2	NEW-SUB-C-209-06.5-S-2	400.00	COPPER ALLOY\LEAD FREE SOLDER
3	K-DOT-.404-.500-.005	1.0000	POLYIMIDE FILM
4	CT-SEAF028MS	.00500	CONDUCTIVE POLYMER

UNLESS OTHERWISE SPECIFIED, DIMENSIONS ARE IN INCHES. TOLERANCES ARE:
 DECIMALS ANGLES
 .XX: \pm .01 [.3] 2°
 .XXX: \pm .005 [.13]
 .XXXX: \pm .0020 [.051]

PROPRIETARY NOTE
 THIS DOCUMENT CONTAINS INFORMATION CONFIDENTIAL AND PROPRIETARY TO SAMTEC, INC. AND SHALL NOT BE REPRODUCED OR TRANSFERRED TO OTHER DOCUMENTS OR DISCLOSED TO OTHERS OR USED FOR ANY PURPOSE OTHER THAN THAT WHICH IT WAS OBTAINED WITHOUT THE EXPRESSED WRITTEN CONSENT OF SAMTEC, INC.

samtec
 520 PARK EAST BLVD, NEW ALBANY, IN 47150
 PHONE: 812-944-6733 FAX: 812-948-5047
 e-Mail: info@SAMTEC.com code: 55322

DO NOT SCALE DRAWING SHEET SCALE: 3:1
 PLATING:
 CONTACT AREA: .000030 GOLD OVER .000050 NICKEL
 REMAINDER: .000200 REF TIN OVER .000050 NICKEL
 F:\DWG\MISC\MKTG\ASP-134486-01-MKT.SLDDRW

DESCRIPTION:
 .050 PITCH SOCKET ARRAY ASSEMBLY
 DWG. NO. ASP-134486-01
 BY: G. PURVIS 11/09/2007 SHEET 1 OF 4

Free Datasheet <http://www.samtec.com/>

RECOMMENDED PCB LAYOUT

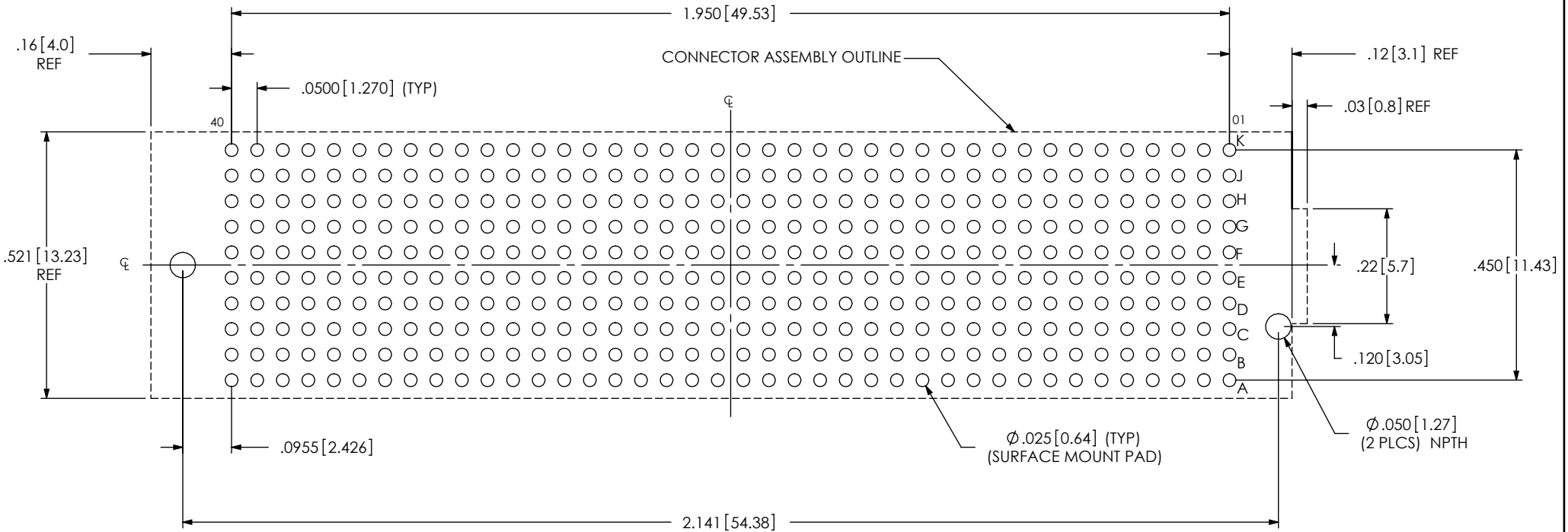

ALL DIMENSIONS ARE SYMMETRIC ABOUT THE CENTERLINE.

PROPRIETARY NOTE

THIS DOCUMENT CONTAINS INFORMATION CONFIDENTIAL AND PROPRIETARY TO SAMTEC, INC. AND SHALL NOT BE REPRODUCED OR TRANSFERRED TO OTHER DOCUMENTS OR DISCLOSED TO OTHERS OR USED FOR ANY PURPOSE OTHER THAN THAT WHICH IT WAS OBTAINED WITHOUT THE EXPRESSED WRITTEN CONSENT OF SAMTEC, INC.



520 PARK EAST BLVD., NEW ALBANY, IN 47150
 PHONE: 812-944-6733 FAX: 812-948-5047
 e-Mail: info@SAMTEC.com code: 55322

SHEET SCALE: 3:1

DESCRIPTION:
 .050 PITCH SOCKET ARRAY ASSEMBLY

DWG. NO. ASP-134486-01
 Free Datasheet <http://www.samtec.com/>

RECOMMENDED STENCIL LAYOUT

NOTE:
STENCIL TO BE .0060[.152] THICK.

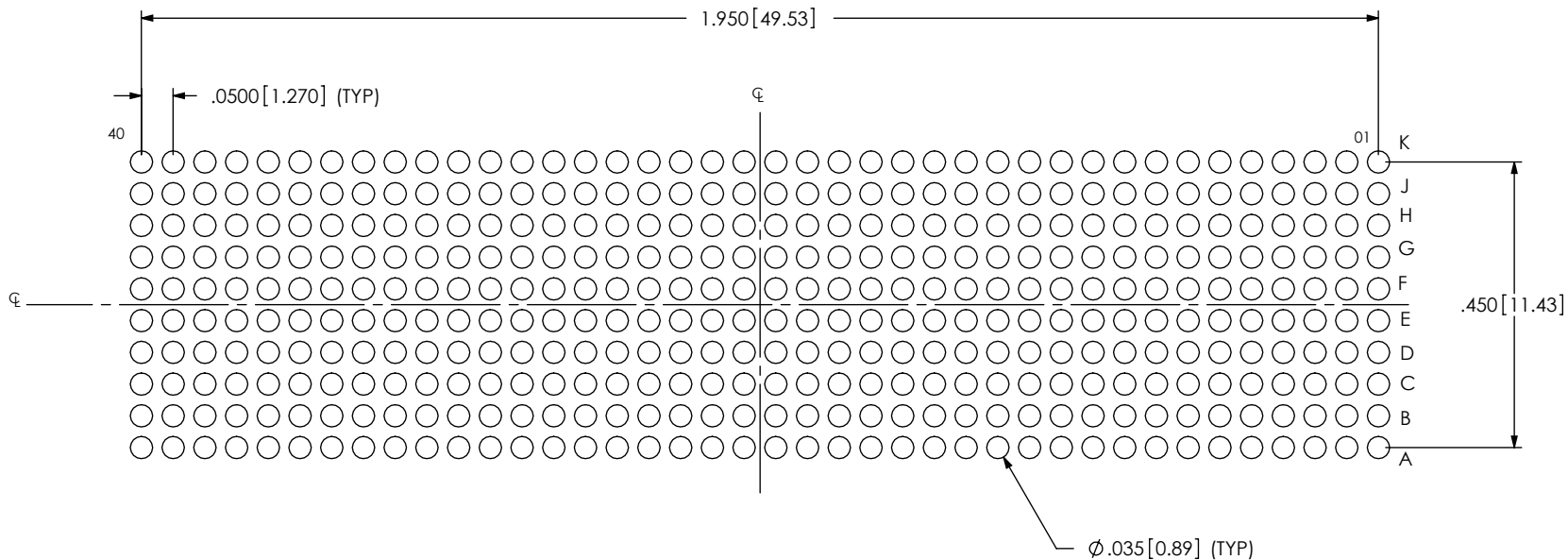

ALL DIMENSIONS ARE SYMMETRIC ABOUT THE CENTERLINE.

<p>PROPRIETARY NOTE THIS DOCUMENT CONTAINS INFORMATION CONFIDENTIAL AND PROPRIETARY TO SAMTEC, INC. AND SHALL NOT BE REPRODUCED OR TRANSFERRED TO OTHER DOCUMENTS OR DISCLOSED TO OTHERS OR USED FOR ANY PURPOSE OTHER THAN THAT WHICH IT WAS OBTAINED WITHOUT THE EXPRESSED WRITTEN CONSENT OF SAMTEC, INC.</p>	<p>samtec 520 PARK EAST BLVD, NEW ALBANY, IN 47150 PHONE: 812-944-6733 FAX: 812-948-5047 e-Mail: info@SAMTEC.com code: 55322</p>
<p>SHEET SCALE: 3:1</p>	<p>DESCRIPTION: .050 PITCH SOCKET ARRAY ASSEMBLY</p>
<p>F:\DWG\MISC\MKTG\ASP-134486-01-MKT.SLDDRW</p>	<p>DWG. NO. ASP-134486-01 Free Datasheet http://www.samtec.com/ BY: G. PURVIS 11/09/2007 SHEET 3 OF 4</p>

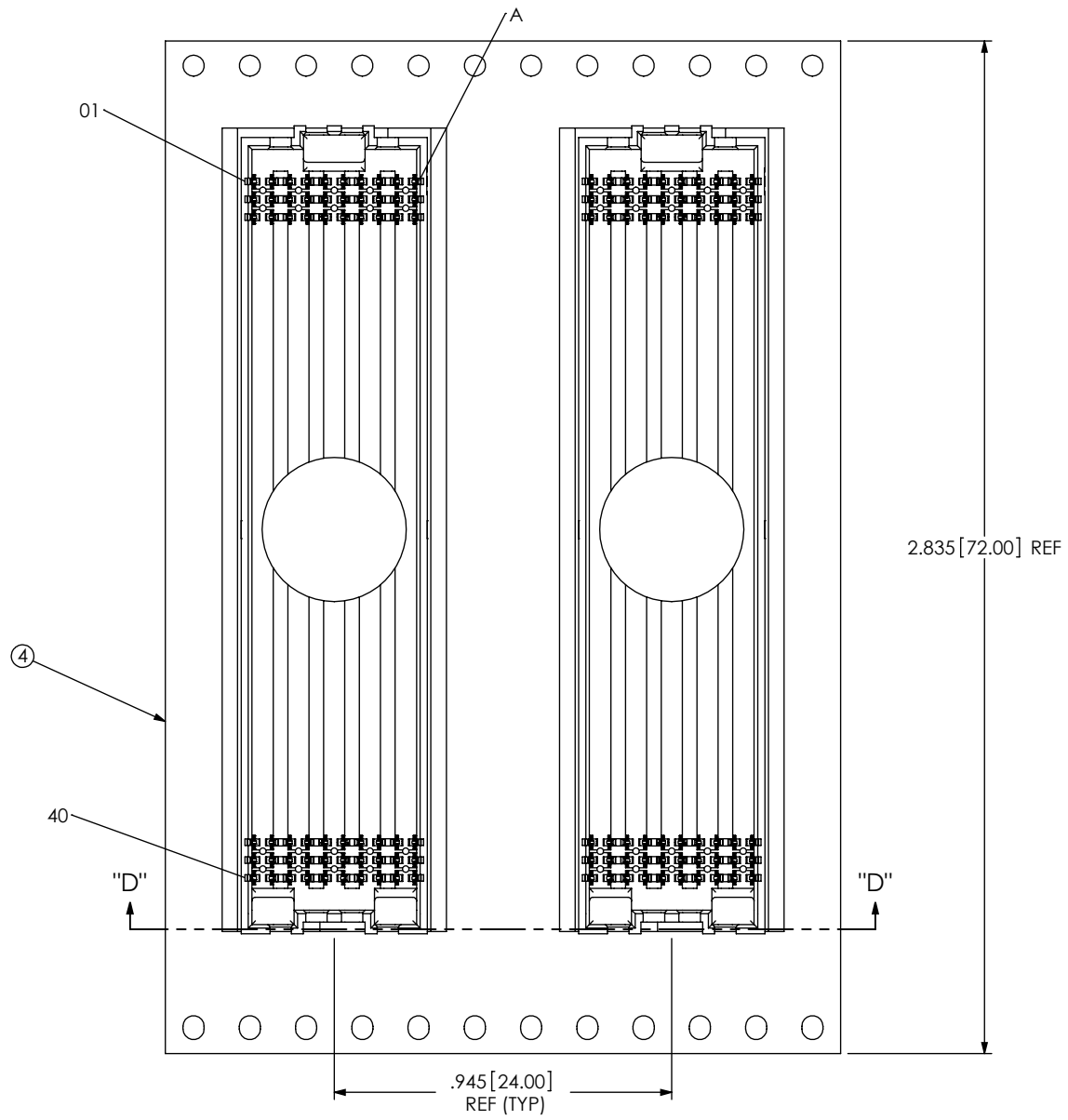

USER DIRECTION OF UN-REELING →
POCKET NOT DETAILED

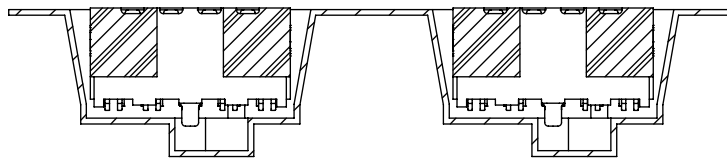

SECTION "D"- "D"
PACKAGING VIEW

PROPRIETARY NOTE

THIS DOCUMENT CONTAINS INFORMATION CONFIDENTIAL AND PROPRIETARY TO SAMTEC, INC. AND SHALL NOT BE REPRODUCED OR TRANSFERRED TO OTHER DOCUMENTS OR DISCLOSED TO OTHERS OR USED FOR ANY PURPOSE OTHER THAN THAT WHICH IT WAS OBTAINED WITHOUT THE EXPRESSED WRITTEN CONSENT OF SAMTEC, INC.



520 PARK EAST BLVD., NEW ALBANY, IN 47150
PHONE: 812-944-6733 FAX: 812-948-5047
e-Mail: info@SAMTEC.com code: 55322

SHEET SCALE: 2:1

DESCRIPTION:
.050 PITCH SOCKET ARRAY ASSEMBLY

DWG. NO. ASP-134486-01
Free Datasheet <http://www.samtec.com/>