

## USB Type-C Analog Audio Switch With Protection Function

### FEATURES

- Power Supply  $V_{CC}$ : 2.7V to 5.5V
- USB High-Speed (480Mbps) Switch
  - SDD<sub>21</sub> -3dB Bandwidth: 950MHz
  - 3Ω  $R_{ON}$  Typical
- Audio Switch
  - Negative Rail Capability: -3V to +3V
  - THD+N = -108dB; 1V<sub>RMS</sub>, f = 20Hz to 20KHz, 32Ω Load
  - 0.9Ω  $R_{ON}$  Typical
- High Voltage Protection
  - 20V DC Tolerance on Connector Side Pins
  - Over Voltage Protection:  $V_{TH}$  = 5V(Typ.)
- OMTP and CTIA Pinout Support
- Support Audio Sense Path
- 25-Ball WLCSP Package (2.24mm x 2.28mm)

### GENERAL DESCRIPTIONS

The ASW5480 is a high performance USB Type-C port Multimedia switch which supports analog audio headsets. ASW5480 allows the sharing of a common USB Type-C port to pass USB2.0 signal, analog audio, sideband use wires and analog microphone signal. ASW5480 also supports high voltage on SBU port and USB port on USB Type-C receptacle side.

### APPLICATIONS

- Mobile Phone
- Tablet
- Notebook PC
- Media Player

### BLOCK DIAGRAM

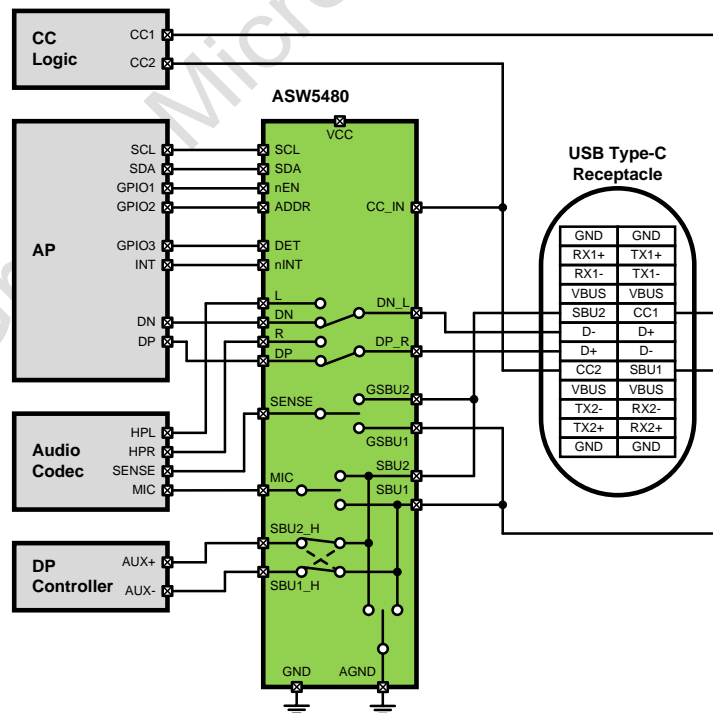

Figure 1, Block Diagram

## Revision History

Note: Page numbers for previous revisions may differ from page numbers in the current version.

VERSION	CHANGE DATE	CHANGE ITEMS
V01	2021/3	Initial version completed.
V02	2021/8	1. Update Resistance Detection flow. 2. Add DET pin notes in page10.
V03	2022/7/5	The device ID was changed from 0x09 to 0x59.
V04	2023/05	Added humidity sensitivity level and Pin1 position description.
V05	2024/01	Update ESD HBM Model.

## PIN DIAGRAM

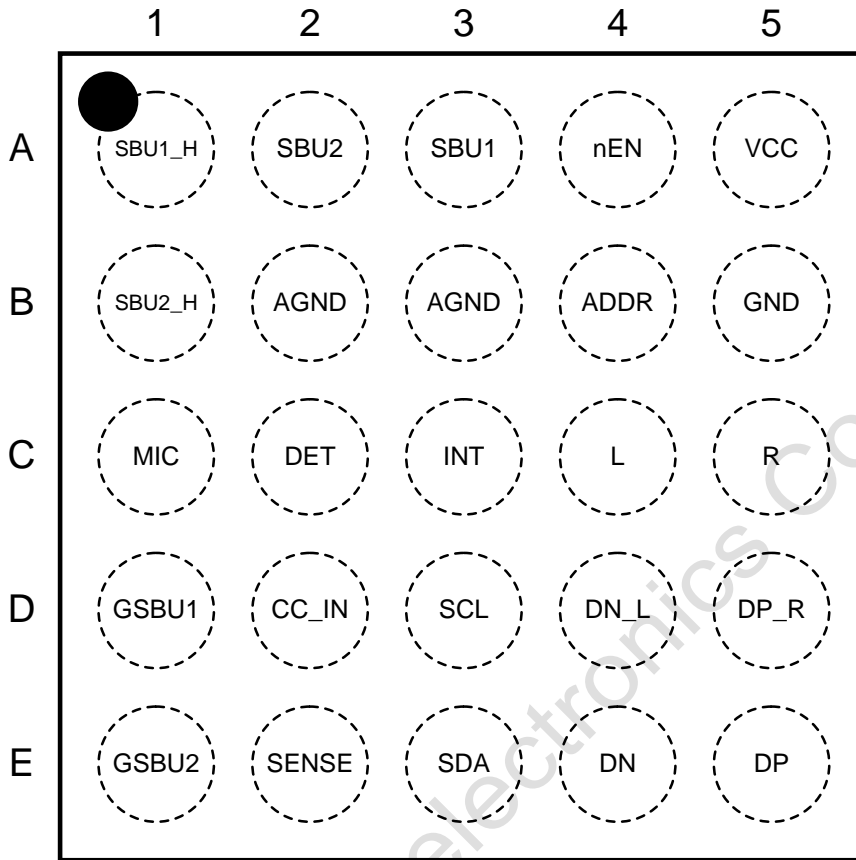

Figure 2, Pin Diagram (Top View)

## PIN DESCRIPTIONS

No.	PIN No.	PIN NAME	TYPE	DESCRIPTIONS
1	A5	VCC	Power	Power Supply (2.7V to 5.5V)
2	B5	GND	Ground	Chip Ground
3	D5	DP_R	I/O	USB/Audio Common Connector
4	D4	DN_L	I/O	USB/Audio Common Connector
5	E5	DP	I/O	USB Data (Differential +)
6	E4	DN	I/O	USB Data (Differential -)
7	C5	R	I/O	Audio Right Channel
8	C4	L	I/O	Audio Left Channel
9	A3	SBU1	I/O	Sideband Use Wire 1
10	A2	SBU2	I/O	Sideband Use Wire 2
11	C1	MIC	I/O	Microphone Signal
12	B2	AGND	Ground	Audio Signal Ground
13	B3	AGND	Ground	Audio Signal Ground
14	E2	SENSE	I/O	Audio Ground Reference Output
15	C3	nINT	O	I <sup>2</sup> C Interrupt Output, Active Low (Open Drain)
16	D2	CC_IN	I	Audio Accessory Attachment Detection Input
17	D1	GSBU1	I/O	Audio Sense Path 1 to Headset Jack GND
18	E1	GSBU2	I/O	Audio Sense Path 2 to Headset Jack GND
19	C2	DET	O	Push-Pull Output. When CC_IN > 1.5V, DET is Low and CC_IN < 1.2V, DET is High
20	D3	SCL	I	I <sup>2</sup> C Clock
21	E3	SDA	I/O	I <sup>2</sup> C Data
22	B1	SBU2_H	I/O	Host Side Sideband Use Wire 2
23	A1	SBU1_H	I/O	Host Side Sideband Use Wire 1
24	A4	nEN	I	Chip Enable, Active Low, Internal Pull-Down by 470kΩ
25	B4	ADDR	I	I <sup>2</sup> C Slave Address Pin

## Absolute Maximum Ratings

Stress exceeding the absolute maximum ratings may damage the device. The device may not function or be operable above the recommended operating conditions and stressing the parts to these levels is not recommended. In addition, extended exposure to stresses above the recommended operating conditions may affect device reliability. The absolute maximum ratings are stress ratings only.

SYMBOL	PARAMETER	MIN	MAX	UNIT
V <sub>CC</sub>	Power Supply Voltage	-0.5	6.5	V
V <sub>CC_IN</sub>	CC_IN to GND	-0.5	20	V
V <sub>SW_C</sub>	DP_R to GND, DN_L to GND	-3.5	20	V
V <sub>SW_USB</sub>	DP to GND, DN to GND	-0.5	6.5	V
V <sub>SW_AUDIO</sub>	L to GND, R to GND	-3.5	6.5	V
V <sub>SBU/GSBU</sub>	SBU1 to GND, SBU2 to GND, GSBU1 to GND, GSBU2 to GND	-0.5	20	V
V <sub>SBU_H</sub>	SBU1_H to GND, SBU2_H to GND	-0.5	6.5	V
V <sub>I/O</sub>	SENSE, MIC, DET, nINT to GND	-0.5	6.5	V
V <sub>CNTRL</sub>	Control Input Voltage (SDA, SCL, nEN, ADDR)	-0.5	6.5	V
I <sub>SW_AUDIO</sub>	Switch I/O Current, Audio Path	-250	250	mA
I <sub>SW_USB</sub>	Switch I/O Current, USB Path		100	mA
I <sub>SW_MIC</sub>	Switch I/O Current, MIC to SBU1 or SBU2		50	mA
I <sub>SW_SBU</sub>	Switch I/O Current, SBUx to SBUx_H		50	mA
I <sub>SW_SENSE</sub>	Switch I/O Current, SENSE to GSBU1 or GSBU2		100	mA
I <sub>SW_AGND</sub>	Switch I/O Current, AGND to SBU1 or SBU2		500	mA
I <sub>IK</sub>	DC Input Diode Current	-50		mA
ESD	HBM Model (Connector Side and Power Pins: VCC, SBU1, SBU2, DP_R, DN_L, GSBU1, GSBU2, CC_IN)	3		KV
	HBM Model (Host Side Pins: the rest pins)	3		KV
	CDM Model	1		KV
T <sub>A</sub>	Absolute Maximum Operating Temperature	-40	+85	°C
T <sub>STG</sub>	Storage Temperature	-65	+150	°C

## Recommended Operating Conditions

The Recommended Operating Conditions table defines the conditions for actual device operation. Recommended operating conditions are specified to ensure optimal performance to the datasheet specifications.

SYMBOL	PARAMETER	MIN	MAX	UNIT
<b>POWER</b>				
V <sub>CC</sub>	Supply Voltage	2.7	5.5	V
<b>USB SWITCH</b>				
V <sub>SW_USB</sub>	DP to GND, DN to GND, DP_R to GND, DN_L to GND	0	3.6	V
<b>AUDIO SWITCH</b>				
V <sub>SW_AUDIO</sub>	DP_R to GND, DN_L to GND, L to GND, R to GND	-3.6	3.6	V
<b>MIC SWITCH</b>				
V <sub>SBU_MIC</sub>	SBU1 to GND, SBU2 to GND, MIC to GND	0	3.6	V
<b>SENSE SWITCH</b>				
V <sub>GSBU_SENSE</sub>	GSBU1 to GND, GSBU2 to GND, SENSE to GND	0	3.6	V
<b>SBU to SBUx_H SWITCH</b>				
V <sub>GSBU</sub>	SBU1 to GND, SBU2 to GND, SBU1_H to GND, SBU2_H to GND	0	3.6	V
<b>CC_IN PIN</b>				
V <sub>CC_IN</sub>	CC_IN to GND	0	5.5	V
<b>CONTROL VOLTAGE (nEN, SDA, SCL)</b>				
V <sub>IH</sub>	Input Voltage High	1.3	V <sub>CC</sub>	V
V <sub>IL</sub>	Input Voltage Low		0.5	V
<b>OPERATING TEMPERATURE</b>				
T <sub>A</sub>	Ambient Operating Temperature	-40	+85	°C

## DC CHARACTERISTICS

All typical values are at  $V_{CC} = 3.3V$  and  $T_A = 25^\circ C$  unless otherwise specified.

SYMBOL	PARAMETER	CONDITIONS	POWER	MIN	TYP	MAX	UNIT
$I_{CC}$	Supply Current	USB Switches on, SBUx to SBUx_H switches on	$V_{CC} = 2.7$ to $5.5V$		39.5	65	$\mu A$
		Audio switches on, MIC switch on and Audio GND switch on			34.5	60	$\mu A$
$I_{CCZ}$	Quiescent Current	$nEN = L, 04H'b7 = 0$				1.2	5
<b>USB/AUDIO COMMON PINS: DP_R, DN_L</b>							
$I_{OZ}$	Off Leakage Current of DP_R and DN_L	$DN\_L, DP\_R = -3V$ to $3.6V$	$V_{CC} = 2.7$ to $5.5V$	-3.0	0.7	3.0	$\mu A$
$I_{OFF}$	Power-Off Leakage Current of DP_R and DN_L	$DN\_L, DP\_R = 0V$ to $3.6V$	Power Off	-3.0	0.7	3.0	$\mu A$
$V_{OV\_TRIP}$	Input OVP Lockout	Rising Edge	$V_{CC} = 2.7$ to $5.5V$	4.5	5	5.3	V
$V_{OV\_HYS}$	Input OVP Hysteresis					0.3	
<b>AUDIO SWITCH</b>							
$I_{ON}$	On Leakage Current of Audio Switch	$DN\_L, DP\_R = -3V$ to $3.0V$ , DP, DN, R, L = Floating	$V_{CC} = 2.7$ to $5.5V$	-2.5	0.4	2.5	$\mu A$
$I_{OFF}$	Power-Off Leakage Current of L and R	L, R = $0V$ to $3V$ , DP_R, DN_L = Floating	Power Off	-1.0		1.0	$\mu A$
$R_{ON\_AUDIO}$	Audio Switch On Resistance	$I_{SW} = 100mA$ , $V_{SW} = -3V$ to $3V$	$V_{CC} = 2.7$ to $5.5V$		0.9	2.1	$\Omega$
$R_{SHUNT}$	Pull-Down Resistor on R/L Pin When Audio Switch is OFF	L = R = $3V$		6	9.8	14	K $\Omega$
<b>USB SWITCH</b>							
$I_{ON}$	On Leakage Current of USB Switch	$DN\_L, DP\_R = 0V$ to $3.0V$ , DP, DN, R, L = Floating	$V_{CC} = 2.7$ to $5.5V$	-3.0	0.5	3.0	$\mu A$
$I_{OZ}$	Off Leakage Current of DP and DN	DN, DP = $0V$ to $3.6V$		-3.0	0.8	3.0	$\mu A$
$I_{OFF}$	Power-Off Leakage Current of DP and DN	DN, DP = $0V$ to $3.6V$	Power OFF	-3.0		3.0	$\mu A$
$R_{ON\_USB}$	USB Switch On Resistance	$I_{SW} = 8mA$ , $V_{SW} = 0.4V$	$V_{CC} = 2.7$ to $5.5V$		2.6	5.2	$\Omega$
<b>SENSE SWITCH</b>							
$I_{ON}$	Leakage Current of Sense Path	GSBUx = $0V$ to $1V$ , SENSE is floating	$V_{CC} = 2.7$ to $5.5V$	-2.0	0.18	2.0	$\mu A$
$R_{ON\_SENSE}$	SENSE Switch On Resistance	$I_{SW} = 100mA$ , $V_{SW} = 1V$		0.2	0.7	1	$\Omega$
$I_{OZ}$	Off Leakage Current of SENSE	SENSE = $0V$ to $1V$		-2.0		2.0	$\mu A$
	Off Leakage Current of GSBUx	GSBUx = $0V$ to $1V$ GSBUx = $1V$ to $3.6V$	-2.0 -3.0		2.0 3.0	$\mu A$ $\mu A$	
$I_{OFF}$	Power-Off Leakage Current of SENSE	SENSE = $0V$ to $1V$	Power Off	-2.0		2.0	$\mu A$
	Power-Off Leakage Current of GSBUx	GSBUx = $0V$ to $3.6V$		-3.0		3.0	$\mu A$
$V_{OV\_TRIP}$	Input OVP Lockout On GSBUx	Rising Edge	$V_{CC} = 2.7$ to $5.5V$	4.5	4.9	5.3	V
$V_{OV\_HYS}$	Input OVP Hysteresis of GSBUx					0.3	V
<b>SBUx PINS</b>							
$I_{OZ}$	Off Leakage Current of SBUx	SBUx = $0V$ to $3.6V$	$V_{CC} = 2.7$ to $5.5V$	-3.0		3.0	$\mu A$
$I_{OFF}$	Power-Off Leakage Current of SBUx	SBUx = $0V$ to $3.6V$	Power OFF	-3.0		3.0	$\mu A$
$V_{OV\_TRIP}$	Input OVP Lockout	Rising Edge	$V_{CC} = 2.7$ to $5.5V$	4.5	4.9	5.3	V
$V_{OV\_HYS}$	Input OVP Hysteresis					0.3	V

## DC CHARACTERISTICS (CONTINUED)

All typical values are at  $V_{CC} = 3.3V$  and  $T_A = 25^\circ C$  unless otherwise specified.

SYMBOL	PARAMETER	CONDITIONS	POWER	MIN	TYP	MAX	UNIT
<b>MIC SWITCH</b>							
$I_{ON}$	On Leakage Current of MIC Switch	$SBUx = 0V$ to $3.6V$ , MIC is floating	$V_{CC} = 2.7$ to $5.5V$	-3.0	0.38	3.0	$\mu A$
$I_{OZ}$	Off Leakage Current of MIC	MIC = $0V$ to $3.6V$		-1.0		1.0	$\mu A$
$I_{OFF}$	Power Off Leakage Current of MIC	MIC = $0V$ to $3.6V$	Power Off	-1.0		1.0	$\mu A$
$R_{ON\_MIC}$	MIC Switch On Resistance	$I_{SW} = 30mA$ , $V_{SW} = 3.6V$	$V_{CC} = 2.7$ to $5.5V$	1.7	3.0	3.9	$\Omega$
<b>SBUx_H SWITCH</b>							
$I_{ON}$	On Leakage Current of SBUx_H Switch	$SBUx = 0V$ to $3.6V$ , SBUx_H = Floating	$V_{CC} = 2.7$ to $5.5V$	-3.0	0.14	3.0	$\mu A$
$I_{OZ}$	Off Leakage Current of SBUx_H	SBUx_H = $0V$ to $3.6V$		-1.0		1.0	$\mu A$
$I_{OFF}$	Power-Off Leakage Current of SBUx_H	SBUx_H = $0V$ to $3.6V$	Power Off	-1.0		1.0	$\mu A$
$R_{ON\_SBUx\_H}$	SBUx_H Switch On Resistance	$I_{SW} = 30mA$ , $V_{SW} = 0V$ to $3.6V$	$V_{CC} = 2.7$ to $5.5V$	1.5	2.7	3.5	$\Omega$
<b>AUDIO GROUND SWITCH (AGND to SBUx)</b>							
$R_{ON\_AGND}$	AGND Switch On Resistance	$I_{SOURCE} = 100mA$ on SBUx	$V_{CC} = 2.7$ to $5.5V$	30	57	90	m $\Omega$
<b>CC_IN PIN</b>							
$V_{TH\_L}$	Input Low Thershold		$V_{CC} = 2.7$ to $5.5V$		1.2		V
$V_{TH\_H}$	Input High Thershold				1.5		V
$I_{IL}$	Input Leakage of CC_IN	CC_IN = $0V$ to $5.5V$				1.0	$\mu A$
<b>nINT, DET PINS</b>							
$V_{OH}$	Output High for DET	$I_o = -2mA$	$V_{CC} = 2.7$ to $5.5V$	1.5	1.8	2.0	V
$V_{OL}$	Output Low for DET and nINT	$I_o = 2mA$				0.4	V
<b>ADDR PIN</b>							
$V_{IH}$	Input Voltage High		$V_{CC} = 2.7$ to $5.5V$	0.9			V
$V_{IL}$	Input Voltage Low					0.7	V
$I_{IL}$	Input Leakage of ADDR	ADDR = $0V$ to $V_{CC}$		-1.0		1.0	$\mu A$
<b>nEN PIN</b>							
$V_{IH}$	Input Voltage High		$V_{CC} = 2.7$ to $5.5V$	0.9			V
$V_{IL}$	Input Voltage Low					0.7	V
$R_{PD}$	Internal Pull-Down Resistor					470	K $\Omega$
<b>SDA, SCL PINS</b>							
$V_{IL\_I2C}$	Input Voltage Low					0.4	V
$V_{IH\_I2C}$	Input Voltage High			1.2			V
$I_{I2C}$	Input Current of SDA and SCL Pins	SDA/SCL = $0V$ to $3.6V$		-2.0		2.0	$\mu A$
$V_{OL\_SDA}$	Output Voltage Low	$I_{OL} = 2mA$				0.3	V
$I_{OL\_SDA}$	Output Current of Output Voltage Low	$V_{OL\_SDA} = 0.2V$		10			mA

## AC CHARACTERISTICS

All typical values are at  $V_{CC} = 3.3V$  and  $T_A = 25^\circ C$  unless otherwise specified.

SYMBOL	PARAMETER	CONDITIONS	POWER	MIN	TYP	MAX	UNIT
<b>AUDIO SWITCH</b>							
$t_{delay}$	Audio Switch Turn On Delay Time	$DP\_R = DN\_L = 1V,$ $R_L = 32\Omega$	$V_{CC} = 3.3V$		40		$\mu s$
$t_{rise}$	Audio Switch Turn On Rising Time <sup>(1)</sup>				200		$\mu s$
$t_{OFF}$	Audio Switch Turn OFF Time				20		$\mu s$
$X_{TALK}$	Cross Talk (Adjacent)	$f = 1KHz, R_L = 50\Omega,$ $V_{SW} = 1V_{RMS}$			-100		dB
BW	-3dB Bandwidth	$R_L = 50\Omega$			600		MHz
$O_{IRR}$	Off Isolation	$f = 1KHz, R_L = 50\Omega,$ $C_L = 0pF, V_{SW} = 1V_{RMS}$			-100		dB
THD+N	Total Harmonic Distortion + Noise Performance With A-Weighting Filter	$f = 20Hz \sim 20KHz, R_L = 600\Omega,$ $V_{SW} = 2V_{RMS}$			-110		dB
		$f = 20Hz \sim 20KHz, R_L = 32\Omega,$ $V_{SW} = 1V_{RMS}$		-108		dB	
		$f = 20Hz \sim 20KHz, R_L = 16\Omega,$ $V_{SW} = 0.5V_{RMS}$		-104		dB	
<b>USB SWITCH</b>							
$t_{ON}$	USB Switch Turn On Time	$DP\_R = DN\_L = 1.5V,$ $R_L = 50\Omega$	$V_{CC} = 3.3V$		60		$\mu s$
$t_{OFF}$	USB Switch Turn Off Time				17		$\mu s$
BW	SDD <sub>21</sub> -3dB Bandwidth	$R_L = 50\Omega$			950		MHz
$O_{IRR}$	Off Isolation Between DP, DN and Common Node Pins	$f = 1KHz, R_L = 50\Omega,$ $C_L = 0pF, V_{SW} = 1V_{RMS}$			-100		dB
$t_{OVP}$	DP_R and DN_L Pins OVP Response Time	$V_{SW} = 3.5V$ to $5.5V$			1	1.5	$\mu s$
<b>MIC/AUDIO GROUND SWITCH</b>							
$t_{delay\_MIC}$	MIC Switch Turn On Delay Time	$SBUx = 1V, R_L = 50\Omega$	$V_{CC} = 3.3V$		40		$\mu s$
$t_{rise\_MIC}$	MIC Switch Turn On Rising Time <sup>(1)</sup>				250		$\mu s$
$t_{delay\_AGND}$	AGND Switch Turn On Time	$SBUx$ pulled up to 0.5V by 16 $\Omega$ , AGND connect to GND			100		$\mu s$
$t_{rise\_AGND}$	AGND Switch Turn On Rising Time <sup>(1)</sup>				2200		$\mu s$
$t_{OFF\_MIC}$	MIC Switch Turn OFF Time	$SBUx = 2.5V, R_L = 50\Omega$			12		$\mu s$
$t_{OFF\_AGND}$	AGND Switch Turn OFF Time	$SBUx: I_{SOURCE} = 10mA,$ Clamp to 2.5V			15		$\mu s$
BW	MIC Switch Bandwidth	$R_L = 50\Omega$			60		MHz
<b>SBUx_H SWITCH</b>							
$t_{ON}$	SBUx_H Switch Turn On Time	$SBUx\_H = 2.5V, R_L = 50\Omega$	$V_{CC} = 3.3V$		60		$\mu s$
$t_{OFF}$	SBUx_H Switch Turn Off Time				10		$\mu s$
BW	-3dB Bandwidth	$R_L = 50\Omega$			60		MHz
$t_{OVP}$	SBUx Pins OVP Response Time	$V_{SW} = 3.5V$ to $5.5V$			0.5	1	$\mu s$
<b>SENSE SWITCH</b>							
$t_{delay}$	SENSE Switch Turn On Delay Time	$GSBUx = 1V, R_L = 50\Omega$	$V_{CC} = 3.3V$		50		$\mu s$
$t_{rise}$	SENSE Switch Turn On Rising Time <sup>(1)</sup>				200		$\mu s$
$t_{OFF}$	SENSE Switch Turn Off Time				12		$\mu s$
$t_{OVP}$	GSBUx Pins OVP Response Time	$V_{SW} = 3.5V$ to $5.5V$			0.7	1.5	$\mu s$
BW	-3dB Bandwidth	$R_L = 50\Omega$			150		MHz

<sup>(1)</sup> Turn On Timing can be controlled by I2C register.

## AC CHARACTERISTICS (CONTINUED)

All typical values are at  $V_{CC} = 3.3V$  and  $T_A = 25^\circ C$  unless otherwise specified.

SYMBOL	PARAMETER	CONDITIONS	POWER	MIN	TYP	MAX	UNIT
<b>DET DELAY</b>							
$t_{\text{delay\_DET}}$	DET Response Delay Time	Transition from 0 to 1.8V	$V_{CC} = 3.3V$		1		$\mu s$
		Transition from 1.8 to 0V			3		$\mu s$

## I<sup>2</sup>C SPECIFICATION (SCL, SDA)

All typical values are at  $V_{CC} = 3.3V$  and  $T_A = 25^\circ C$  unless otherwise specified.

SYMBOL	PARAMETER	FAST MODE		
		MIN	MAX	UNIT
$f_{SCL}$	I <sup>2</sup> C SCL Clock Frequency		400	KHz
$t_{HD;STA}$	Hold Time (repeated) START Condition	0.6		$\mu s$
$t_{LOW}$	Low Period of I <sup>2</sup> C SCL Clock	1.3		$\mu s$
$t_{HIGH}$	High Period of I <sup>2</sup> C SCL Clock	0.6		$\mu s$
$t_{SU;STA}$	Set-up Time for Repeated START Condition	0.6		$\mu s$
$t_{HD;DAT}$	Data Hold Time <sup>(2)</sup>	0	0.9	$\mu s$
$t_{SU;DAT}$	Data Set-up Time <sup>(3)</sup>	100		ns
$t_r$	Rise Time of I <sup>2</sup> C SDA and I <sup>2</sup> C SCL Signals <sup>(3)</sup>	$20 + 0.1C_b$	300	ns
$t_f$	Fall Time of I <sup>2</sup> C SDA and I <sup>2</sup> C SCL Signals <sup>(3)</sup>	$20 + 0.1C_b$	300	ns
$t_{SU;STO}$	Set-up Time for STOP Condition	0.6		$\mu s$
$t_{BUF}$	Bus-Free Time Between STOP and START Conditions	1.3		$\mu s$
$t_{SP}$	Pulse Width of Spikes that Must Be Suppressed by the Input Filter	0	50	ns

<sup>(2)</sup>Guaranteed by design, not production tested.

<sup>(3)</sup>A fast-mode I<sup>2</sup>C bus device can be used in a standard-mode I<sup>2</sup>C bus system, but the requirement  $t_{SU;DAT} \geq \pm 250ns$  must be met. This is automatically the case if the device does not stretch the LOW period of the I<sup>2</sup>C SCL signal. If such a device does stretch the LOW period of the I<sup>2</sup>C SCL signal, it must output the next data bit to the I<sup>2</sup>C SDA line  $t_{r,max} + t_{SU;DAT} = 1000 + 250 = 1250ns$  (according to the standard-mode I<sup>2</sup>C bus specification) before the I<sup>2</sup>C SCL line is released.

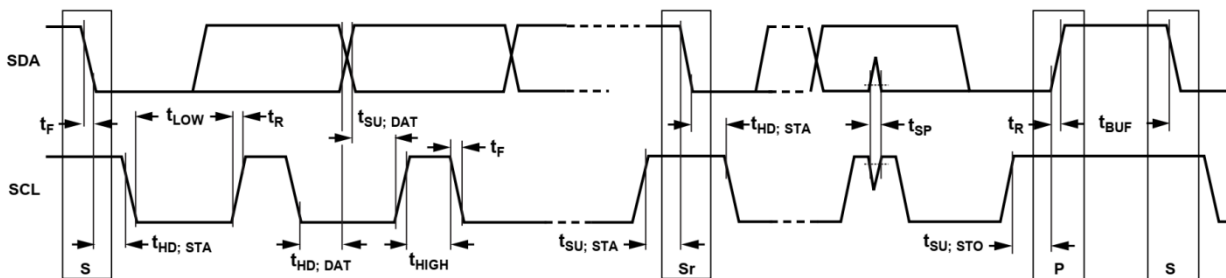

Figure 3, Definition of Timing for Full-Speed Mode Devices on the I<sup>2</sup>C Bus



## CAPACITANCE

All typical values are at  $V_{CC} = 3.3V$  and  $T_A = 25^\circ C$  unless otherwise specified.

SYMBOL	PARAMETER	CONDITIONS	POWER	$T_A = -40^\circ C \text{ to } 85^\circ C$			UNIT
				MIN	TYP	MAX	
CON_USB/AUDIO	On Capacitance (Common Port)	$f = 1MHz, 100mV_{PK-PK}, 100mV \text{ DC Bias}$	$V_{CC} = 3.3V$		9		pF
COFF_USB/AUDIO	Off Capacitance (Common Port)	$f = 1MHz, 100mV_{PK-PK}, 100mV \text{ DC Bias}$			7.5		pF
COFF_USB	Off Capacitance (Non-Common Ports)	$f = 1MHz, 100mV_{PK-PK}, 100mV \text{ DC Bias}$			3		pF
CON_SENSE_SW	On Capacitance (Common Port)	$f = 1MHz, 100mV_{PK-PK}, 100mV \text{ DC Bias}$			55		pF
COFF_SENSE_SW	Off Capacitance (Common Port)	$f = 1MHz, 100mV_{PK-PK}, 100mV \text{ DC Bias}$			88		pF
CON_MIC_SW	On Capacitance (Common Port)	$f = 1MHz, 100mV_{PK-PK}, 100mV \text{ DC Bias}$			170		pF
COFF_MIC_SW	Off Capacitance (Common Port)	$f = 1MHz, 100mV_{PK-PK}, 100mV \text{ DC Bias}$			10		pF
CON_AGND_SW	On Capacitance (Common Port)	$f = 1MHz, 100mV_{PK-PK}, 100mV \text{ DC Bias}$			125		pF
CON_SBUx_H_SW	On Capacitance (Common Port)	$f = 1MHz, 100mV_{PK-PK}, 100mV \text{ DC Bias}$			160		pF
CCNTRL	Control Input Pin Capacitance (nEN Pin)	$f = 1MHz, 100mV_{PK-PK}, 100mV \text{ DC Bias}$			3		pF

## APPLICATION INFORMATION

### Over-Voltage Protection

The ASW5480 features Over-Voltage Protection (OVP) on receptacle side pins that switch off the internal signal routing path if the input voltage exceeds the OVP threshold. If OVP is occurred, interrupt signal can be send by nINT signal and FLAG data will provide information that which pin had OVP event.

### Headset Detection

The ASW5480 integrates headset unplug detection function by detecting the CC\_IN voltage. The function is always active when device is enabling<sup>(4)</sup>. DET will be high when CC\_IN is Low ( $CC\_IN < 1.2V$ ). When CC\_IN is High ( $CC\_IN > 1.5V$ ), DET will be released to low.

	ASW5480 Disable	ASW5480 Enable
$CC\_IN < V_{TH\_L} = 1.2V$	DET = 0	DET = 1
$CC\_IN > V_{TH\_H} = 1.5V$	DET = 0	DET = 0

<sup>(4)</sup> DET pin is in Push/Pull Configuration as default . If you don't use this detection function , leave it floating.

### MIC Switch Auto-Off Function

The function is active during control bit 0x12h bit[2] = 1. When CC\_IN is high ( $CC\_IN > 1.5V$ ) and L, R, Audio ground switches are under on status, MIC switch will be off and receptacle side pin will be connected to ground for 50 $\mu$ s first. Then it shows High-Z status under MIC switch is set on status.

### Audio Ground Detection and Configuration

The function is active during control bit 0x12h bit[0] = 1 and R, L, AGND switches are set to be on status. For Type-C interface analog headset, the audio ground could be SBU1 pin or SBU2 pin. The function will provide autonomous detection and configuration to route MIC and audio ground signal accordingly.

During detection and configuration, the L, R, SENSE, MIC and Audio ground switch will be off. After detection and configuration, L and R switches will turn on according to switch configuration and timing setting. MIC, SENSE and Audio ground will turn on according to detection results and timing control setting.

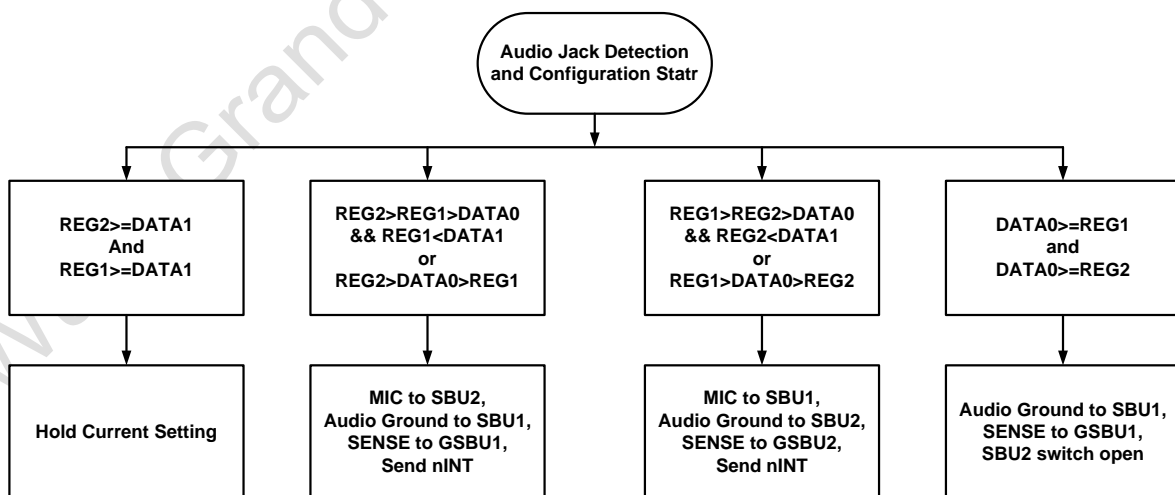

Figure 4, Audio Ground Detection and Configuration

## Resistance Detection

The function is active during control bit 0x12h bit[1] = 1. It will monitor the resistance between receptacle side pins and ground. During resistance detection, the switch which is monitored will be off. The detection result will be saved in the resistance flag register. The measurement could be from 1KΩ to 2.56MΩ which is controlled by internal register. The detection interval can be set at 100ms, 1s or 10s by register 0x16h.

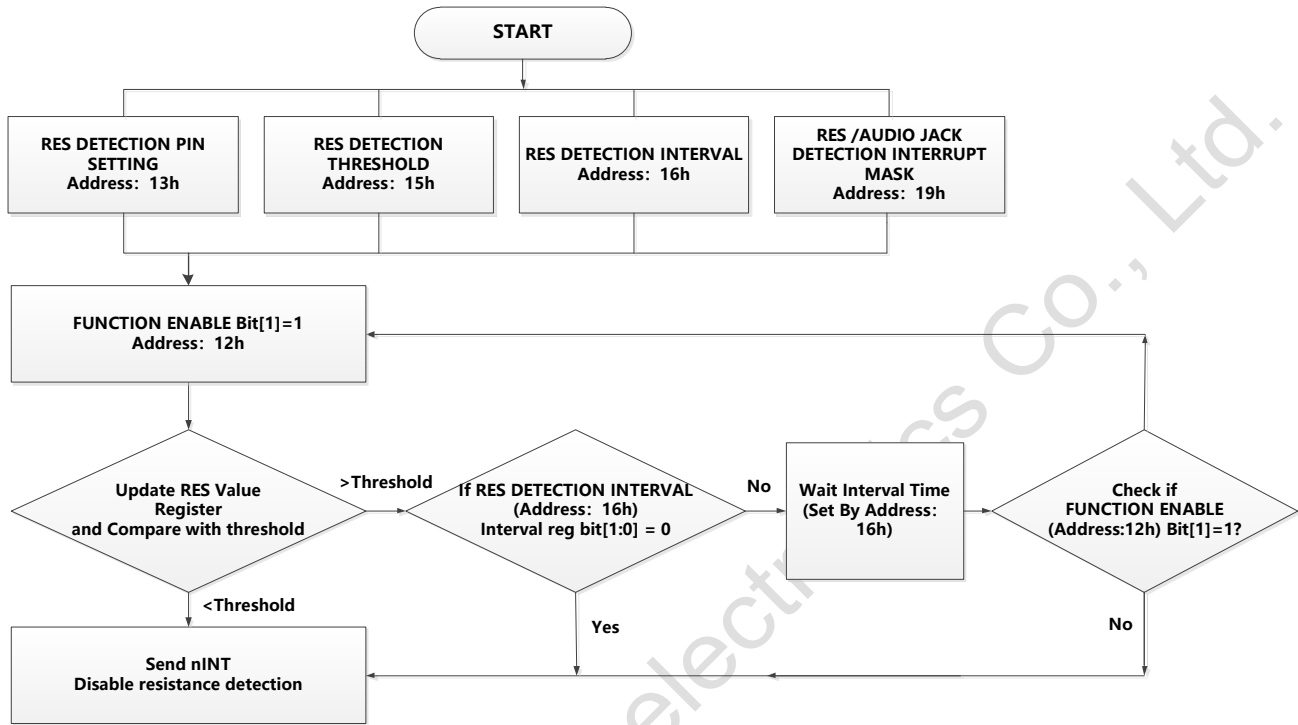

Figure 5, Resistance Detection

## Manual Switch Control

The function is active during control bit 0x12h bit[4] = 1 and 0x04h = FF. it will provide manual control for device. During this configuration, ADDR and nINT pins will be set as logic control input.

Power	nEN	ADDR	nINT	SENSE Switch	Headset Detection	USB Switch	Audio Switch	MIC/ AGND Switch	SBU Bypass Switch
OFF	X	X	X	OFF	OFF	OFF	OFF	OFF	OFF
ON	H	X	X	OFF	OFF	OFF	OFF	OFF	OFF
ON	L	0	0	OFF	OFF	ON: DP_R to DP, DN_L to DN	OFF	OFF	ON: SBU1 to SBU1_H, SBU2 to SBU2_H
ON	L	0	1	OFF	OFF	ON: DP_R to DP, DN_L to DN	OFF	OFF	ON: SBU1 to SBU2_H, SBU2 to SBU1_H
ON	L	1	0	ON: GSBU2 to SENSE	ON	OFF	ON: DP_R to R, DN_L to L	ON: SBU1 to MIC, SBU2 to AGND	OFF
ON	L	1	1	ON: GSBU1 to SENSE	ON	OFF	ON: DP_R to R, DN_L to L	ON: SBU2 to MIC, SBU1 to AGND	OFF

## I2C INTERFACE

The ASW5480 includes a full I<sup>2</sup>C slave controller. The I<sup>2</sup>C slave fully complies with I<sup>2</sup>C specification version 2.1 requirements. This block is designed for fast mode, 400-KHz signals. Examples of an I<sup>2</sup>C write and read sequence are shown in below figures respectively.

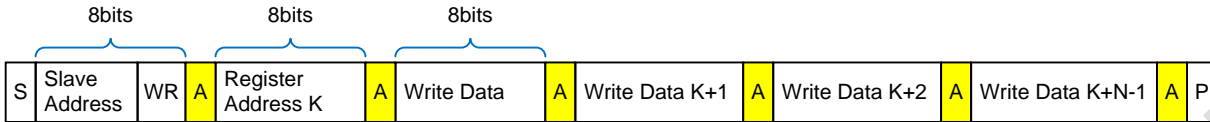

NOTE: Single Byte Read is initiated by Master with P immediately following first data byte.

Figure 6, I<sup>2</sup>C Write Example

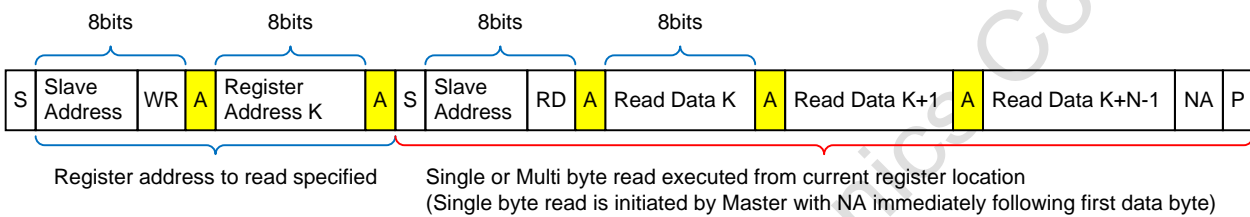

NOTE: If Register is not specified Master will begin read from current register. In this case only sequence showing in Red bracket is needed.

	From Master to Slave	S	Start Condition	NA	Not Acknowledge (SDA High)	RD	Read = 1
	From Slave to Master	A	Acknowledge (SDA Low)	WR	Write = 0	P	Stop Condition

Figure 7, I<sup>2</sup>C Read Example

Table 1, I<sup>2</sup>C Slave Address

ADDR	Bit7	Bit6	Bit5	Bit4	Bit3	Bit2	Bit1	Bit0
ADDR = L	1	0	0	0	0	1	0	R/W
ADDR = H	1	0	0	0	0	1	1	R/W

## REGISTER MAPS

ADDR	Register Name	Type	Reset Value	Bit7	Bit6	Bit5	Bit4	Bit3	Bit2	Bit1	Bit0	
00H	Device ID	R	0x59	0	1	0	1	1	0	0	1	
01H	OVP Interrupt Mask	R/W	0x00	Reserved	Mask OVP Interrupt	Mask OVP /DP_R	Mask OVP /DN_L	Mask OVP /SBU1	Mask OVP /SBU2	Mask OVP /GSBU1	Mask OVP /GSBU2	
02H	OVP Interrupt flag	R/C	0x00	Reserved		DP_R	DN_L	SBU1	SBU2	GSBU1	GSBU2	
03H	OVP Status	R	0x00	Reserved		OVP /DP_R	OVP /DN_L	OVP /SBU1	OVP /SBU2	OVP /GSBU1	OVP /GSBU2	
04H	Switch settings Enable	R/W	0x98	Device Control	SBU1_H to SBUx	SBU2_H to SBUx	DN_L to DN or L	DP_R to DP or R	Sense to GSBUX	MIC to SBUx	Audio Ground to SBUx	
05H	Switch Select	R/W	0x18	Reserved	SBU1_H to SBUx	SBU2_H to SBUx	DN_L to DN or L	DP_R to DP or R	Sense to GSBUX	MIC to SBUx	Audio Ground to SBUx	
06H	Switch Status0	R	0x05	Reserved		Sense Switch Status		DP_R Switch Status		DN_L Switch Status		
07H	Switch Status1	R	0x00	Reserved		SBU2 Switch Status			SBU1 Switch Status			
08H	Audio switch left channel turn on control	R/W	0x01	Audio Switch Left Channel Slow Control [7:0]								
09H	Audio switch right channel turn on control	R/W	0x01	Audio Switch Right Channel Slow Control [7:0]								
0AH	MIC switch turn on control	R/W	0x01	MIC Switch Right Channel Slow Control [7:0]								
0BH	Sense switch turn on control	R/W	0x01	SENSE Switch Right Channel Slow Control [7:0]								
0CH	Audio Ground Switch turn on control	R/W	0x01	Audio Ground Switch Right Channel Slow Control [7:0]								
0DH	Timing Delay between R switch enable and L switch enable	R/W	0x00	Timing Delay Between R Switch Enable and L Switch Enable Control [7:0]								
0EH	Timing Delay between MIC switch enable and L switch enable	R/W	0x00	Timing Delay Between MIC Switch Enable and L Switch Enable Control [7:0]								
0FH	Timing Delay between Sense switch enable and L switch enable	R/W	0x00	Timing Delay Between Sense Switch Enable and L Switch Enable Control [7:0]								
10H	Timing Delay between Audio Ground switch enable and L switch enable	R/W	0x00	Timing Delay Between Audio Ground Switch Enable and L Switch Enable Control [7:0]								
11H	Audio accessory status	R	0x02	Reserved						CC_IN	DET	
12H	Function Enable	R/W	0x08	Reserved	DET I/O Control	RES	GPIO Control	Slow turn-on Control	MIC Auto Control	RES detection: auto clear	Audio jack detection: auto clear	
13H	RES detection pin setting	R/W	0x00	Reserved					Detection pin select [2:0]			

## REGISTER MAPS(CONTINUED)

ADDR	Register Name	Type	Reset Value	Bit7	Bit6	Bit5	Bit4	Bit3	Bit2	Bit1	Bit0	
14H	RES detection value	R	0xFF	R detection value [7:0]								
15H	RES detection interrupt threshold	R/W	0x16	R detection interrupt resistance threshold [7:0]								
16H	RES detection interval	R/W	0x00	Reserved						Detection interval [1:0]		
17H	Audio jack status	RO	0x01	Reserved			4-pole, SBU2 MIC	4-pole, SBU1 MIC	3-pole	No audio		
18H	Detection interrupt	R/C	0x00	Reserved				Audio detection done	RES detection occurred	RES detection done		
19H	Detection interrupt Mask	R/W	0x00	Reserved				Audio detection done mask	RES detection occurred mask	RES detection done mask		
1AH	Audio detection REG1	RO	0xFF	Audio detection value REG1 [7:0]								
1BH	Audio detection REG2	RO	0xFF	Audio detection value REG2 [7:0]								
1CH	MIC threshold DATA0	R/W	0x20	MIC Threshold value DATA0 [7:0]								
1DH	MIC threshold DATA1	R/W	0xFF	MIC Threshold value DATA1 [7:0]								
1EH	I2C reset	W/C	0x00	Reserved								I2C reset
1FH	Current source setting	R/W	0x07	Reserved			Current Source Setting [3:0]					

**Table 2, DEVICE ID**

(Register 0x00h, Reset Value: 0x59, Type: Read)

BITS	NAME	SIZE	DESCRIPTION
7:6	Vendor ID	2	Vendor ID
5:3	Version ID	3	Device Version ID
2:0	Revision ID	3	Revision History ID

**Table 3, OVP INTERRUPT MASK**

(Register 0x01h, Reset Value: 0x00, Type: Read/Write)

BITS	NAME	SIZE	DESCRIPTION
7	Reserved	1	Do not use
6	OVP Interrupt mask control	1	OVP Interrupt function enable/disable 0: controlled by [5:0] bit 1: Mask all connector side pins OVP interrupt
5	DP_R OVP Interrupt mask control	1	0: Do not mask OVP interrupt 1: Mask OVP interrupt
4	DN_L OVP Interrupt mask control	1	0: Do not mask OVP interrupt 1: Mask OVP interrupt
3	SBU1 OVP Interrupt mask control	1	0: Do not mask OVP interrupt 1: Mask OVP interrupt
2	SBU2 OVP Interrupt mask control	1	0: Do not mask OVP interrupt 1: Mask OVP interrupt
1	G SBU1 OVP Interrupt mask control	1	0: Do not mask OVP interrupt 1: Mask OVP interrupt
0	G SBU2 OVP Interrupt mask control	1	0: Do not mask OVP interrupt 1: Mask OVP interrupt

**Table 4, OVP INTERRUPT FLAG**

(Register 0x02h, Reset Value: 0x00, Type: Read Clear)

BITS	NAME	SIZE	DESCRIPTION
7:6	Reserved	2	Do not use
5	DP_R OVP	1	0: OVP event has not occurred 1: OVP event has occurred
4	DN_L OVP	1	0: OVP event has not occurred 1: OVP event has occurred
3	SBU1 OVP	1	0: OVP event has not occurred 1: OVP event has occurred
2	SBU2 OVP	1	0: OVP event has not occurred 1: OVP event has occurred
1	GSBU1 OVP	1	0: OVP event has not occurred 1: OVP event has occurred
0	GSBU2 OVP	1	0: OVP event has not occurred 1: OVP event has occurred

**Table 5, OVP STATUS**

(Register 0x03h, Reset Value: 0x00, Type: Read)

BITS	NAME	SIZE	DESCRIPTION
7:6	Reserved	2	Do not use
5	OVP on DP_R Pin	1	0: OVP event has not occurred 1: OVP event has occurred
4	OVP on DN_L Pin	1	0: OVP event has not occurred 1: OVP event has occurred
3	OVP on SBU1 Pin	1	0: OVP event has not occurred 1: OVP event has occurred
2	OVP on SBU2 Pin	1	0: OVP event has not occurred 1: OVP event has occurred
1	OVP on GSBU1 Pin	1	0: OVP event has not occurred 1: OVP event has occurred
0	OVP on GSBU2 Pin	1	0: OVP event has not occurred 1: OVP event has occurred

**Table 6, SWITCHING SETTING ENABLE**

(Register 0x04h, Reset Value: 0x98, Type: Read/Write)

BITS	NAME	SIZE	DESCRIPTION
7	Device Enable	1	0: Device Disable; L, R are pulled-down by 10kΩ and other switch nodes will be High-Z for positive input. 1: Device Enable.
6	SBU1_H to SBUx switches	1	0: Switch Disable; SBU1_H will be High-Z for positive input; 1: Switch Enable.
5	SBU2_H to SBUx switches	1	0: Switch Disable; SBU2_H will be High-Z for positive input; 1: Switch Enable.
4	DN_L to DN or L switches	1	0: Switch Disable; DN_L, DN will be High-Z for positive input and L is pulled-down by 10kΩ. 1: Switch Enable.
3	DP_R to DP or R switches	1	0: Switch Disable; DP_R, DP will be High-Z for positive input and R is pulled-down by 10kΩ. 1: Switch Enable.
2	Sense to GSBUx switches	1	0: Switch Disable; Sense, GSBU1 and GSBU2 will be High-Z for positive input. 1: Switch Enable.
1	MIC to SBUx switches	1	0: Switch Disable; MIC will be High-Z for positive input. 1: Switch Enable.
0	AGND to SBUx switches	1	0: Switch Disable; AGND will be High-Z for positive input. 1: Switch Enable.

**Table 7, SWITCH SELECT**

(Register 0x05h, Reset Value: 0x18, Type: Read/Write)

BITS	NAME	SIZE	DESCRIPTION
7	Reserved	1	Do not use
6	SBU1_H switches	1	0: SBU1_H to SBU1 switch ON 1: SBU1_H to SBU2 switch ON
5	SBU2_H switches	1	0: SBU2_H to SBU2 switch ON 1: SBU2_H to SBU1 switch ON
4	DN_L or DN or L switches	1	0: DN_L to L switch ON 1: DN_L to DN switch ON
3	DP_R or DP or R switches	1	0: DP_R to R switch ON 1: DP_R to DP switch ON
2	Sense to GSBUX switches	1	0: Sense to GSBU1 switch ON 1: Sense to GSBU2 switch ON
1	MIC to SBUx switches	1	0: MIC to SBU2 switch ON 1: MIC to SBU1 switch ON
0	AGND to SBUx switches	1	0: AGND to SBU1 switch ON 1: AGND to SBU2 switch ON

**Table 8, SWITCH STATUS0**

(Register 0x06h, Reset Value: 0x05, Type: Read)

BITS	NAME	SIZE	DESCRIPTION
7:6	Reserved	2	Do not use
5:4	Sense Switch Status	2	00: Sense switch is Open/Not Connected 01: Sense connected to GSBU1 10: Sense connected to GSBU2 11: Not Valid
3:2	DP_R Switch Status	2	00: DP_R switch is Open/Not Connected 01: DP_R connected to DP 10: DP_R connected to R 11: Not Valid
1:0	DN_L Switch Status	2	00: DN_L switch is Open/Not Connected 01: DN_L connected to DN 10: DN_L connected to L 11: Not Valid

**Table 9, SWITCH STATUS1**

(Register 0x07h, Reset Value: 0x00, Type: Read)

BITS	NAME	SIZE	DESCRIPTION
7:6	Reserved	2	Do not use
5:3	SBU2 SwitchStatus	3	000: SBU2 switch is Open/Not Connected 001: SBU2 connected to MIC 010: SBU2 connected to AGND 011: SBU2 connected to SBU1_H 100: SBU2 connected to SBU2_H 101: SBU2 connected both SBU1_H and SBU2_H 110...111: Do not use
2:0	SBU1 SwitchStatus	3	000: SBU1 switch is Open/Not Connected 001: SBU1 connected to MIC 010: SBU1 connected to AGND 011: SBU1 connected to SBU1_H 100: SBU1 connected to SBU2_H 101: SBU1 connected both SBU1_H and SBU2_H 110...111: Do not use

**Table 10, AUDIO SWITCH LEFT CHANNEL SLOW TURN-ON**

(Register 0x08h, Reset Value: 0x01, Type: Read/Write)

BITS	NAME	SIZE	DESCRIPTION
7:0	Switch turn on rising time setting	8	11111111: 25600μs ... 00000001: 200μs 00000000: 100μs



**Table 11, AUDIO SWITCH RIGHT CHANNEL SLOW TURN-ON**  
 (Register 0x09h, Reset Value: 0x01, Type: Read/Write)

BITS	NAME	SIZE	DESCRIPTION
7:0	Switch turn on rising time setting	8	11111111: 25600μs
			...
			00000001: 200μs
			00000000: 100μs

**Table 12, MIC SWITCH SLOW TURN-ON**  
 (Register 0x0Ah, Reset Value: 0x01, Type: Read/Write)

BITS	NAME	SIZE	DESCRIPTION
7:0	Switch turn on rising time setting	8	11111111: 25700μs
			...
			00000010: 350μs
			00000001: 250μs
			00000000: Not Valid

**Table 13, SENSE SWITCH SLOW TURN-ON**  
 (Register 0x0Bh, Reset Value: 0x01, Type: Read/Write)

BITS	NAME	SIZE	DESCRIPTION
7:0	Switch turn on rising time setting	8	11111111: 25600μs
			...
			00000001: 200μs
			00000000: 100μs

**Table 14, AUDIO GROUND SWITCH SLOW TURN-ON**  
 (Register 0x0Ch, Reset Value: 0x01, Type: Read/Write)

BITS	NAME	SIZE	DESCRIPTION
7:0	Switch turn on rising time setting	8	11111111: 179000μs
			...
			00000001: 1400μs
			00000000: 700μs

**Table 15, TIMING DELAY BETWEEN R SWITCH ENABLE AND L SWITCH ENABLE**  
 (Register 0x0Dh, Reset Value: 0x00, Type: Read/Write)

BITS	NAME	SIZE	DESCRIPTION
7:0	Delay timing setting	8	11111111: 25500μs
			11111110: 25400μs
			...
			00000001: 100μs
			00000000: 0μs

**Table 16, TIMING DELAY BETWEEN MIC SWITCH ENABLE AND L SWITCH ENABLE**  
 (Register 0x0Eh, Reset Value: 0x00, Type: Read/Write)

BITS	NAME	SIZE	DESCRIPTION
7:0	Delay timing setting	8	11111111: 25500μs
			11111110: 25400μs
			...
			00000001: 100μs
			00000000: 0μs

**Table 17, TIMING DELAY BETWEEN SENSE SWITCH ENABLE AND L SWITCH ENABLE**  
 (Register 0x0Fh, Reset Value: 0x00, Type: Read/Write)

BITS	NAME	SIZE	DESCRIPTION
7:0	Delay timing setting	8	11111111: 25500μs
			11111110: 25400μs
			...
			00000001: 100μs
			00000000: 0μs

**Table 18, TIMING DELAY BETWEEN AUDIO GROUND SWITCH ENABLE AND L SWITCH ENABLE**  
 (Register 0x10h, Reset Value: 0x00, Type: Read/Write)

BITS	NAME	SIZE	DESCRIPTION
7:0	Delay timing setting	8	11111111: 25500μs 11111110: 25400μs ... 00000001: 100μs 00000000: 0μs

**Table 19, AUDIO ACCESSORY STATUS**  
 (Register 0x11h, Reset Value: 0x02, Type: Read)

BITS	NAME	SIZE	DESCRIPTION
7:2	Reserved	6	Do not use
1	CC_IN	1	0: CC_IN < 1.2V 1: CC_IN > 1.5V
0	DET	1	0: DET output is Low 1: DET output is High

**Table 20, FUNCTION ENABLE**  
 (Register 0x12h, Reset Value: 0x08, Type: Read/Write)

BITS	NAME	SIZE	DESCRIPTION
7	Reserved	1	Do not use
6	DET I/O Control	1	1: DET pin is in Open/Drain Configuration 0: DET pin is in Push/Pull Configuration
5	RES detection range setting	1	1: 10KΩ to 2560KΩ 0: 1KΩ to 256KΩ
4	GPIO control enable	1	1: Enable 0: Disable
3	Slow turn on control enable	1	1: Enable 0: Disable
2	MIC auto break out control enable	1	1: Enable 0: Disable
1	RES detection enable	1	1: Enable; will be changed to '0' after low resistance detection 0: Disable
0	Audio jack detection and configuration enable	1	1: Enable; will be changed to '0' after audio jack detection and configuration 0: Disable

**Table 21, RES DETECTION PIN SETTING**  
 (Register 0x13h, Reset Value: 0x00, Type: Read/Write)

BITS	NAME	SIZE	DESCRIPTION
7:3	Reserved	5	Do not use
2:0	Pin Selection	3	000: CC_IN 001: DP_R 010: DN_L 011: SBU1 100: SBU2 101...111: Do not use

*Note: if RES detection pin is enable before setting PIN selection it will always do the CC\_IN first. Recommend user to select the pin first before setting the RES detection pin enable.*

**Table 22, RES VALUE**  
 (Register 0x14h, Reset Value: 0xFF, Type: Read)

BITS	NAME	SIZE	DESCRIPTION
7:0	Detected resistance value	8	00000000: R < 1KΩ ... 11111111: R > 300KΩ

**Table 23, RES DETECTION THRESHOLD**

(Register 0x15h, Reset Value: 0x16, Type: Read/Write)

BITS	NAME	SIZE	DESCRIPTION
7:0	RES detection threshold	8	Selection by 1KΩ per step if Register 12h[5] = 0 Selection by 10KΩ per step if Register 12h[5] = 1 Default Value = 22KΩ  00000000: 1KΩ/10KΩ ... 11111111: 256KΩ/2560KΩ

**Table 24, RES DETECTION INTERVAL**

(Register 0x16h, Reset Value: 0x00, Type: Read/Write)

BITS	NAME	SIZE	DESCRIPTION
7:2	Reserved	6	Do not use
1:0	RES detection interval	2	00: Single 01: 100ms 10: 1s 11: 10s

**Table 25, AUDIO JACK STATUS**

(Register 0x17h, Reset Value: 0x01, Type: Read)

BITS	NAME	SIZE	DESCRIPTION
7:4	Reserved	4	Do not use
3	4pole	1	1: 4 pole SBU2 to MIC, SBU1 to Audio Ground 0: others
2	4pole	1	1: 4 pole SBU1 to MIC, SBU2 to Audio Ground 0: others
1	3pole	1	1: 3 pole 0: others
0	No Audio Accessory	1	1: No Audio Accessory 0: Audio Accessory Attached

**Table 26, RES DETECTION/AUDIO JACK DETECTION INTERRUPT FLAG**

(Register 0x18h, Reset Value: 0x00, Type: Read Clear)

BITS	NAME	SIZE	DESCRIPTION
7:3	Reserved	5	Do not use
2	Audio jack detection and configuration	1	1: Audio jack detection and configuration has not occurred 0: Audio jack detection and configuration has occurred
1	Low resistance occurred	1	1: Low resistance has not occurred 0: Low resistance has occurred
0	Low resistance detection	1	1: Low resistance detection has not occurred 0: Low resistance detection has occurred

**Table 27, RES DETECTION /AUDIO JACK DETECTION INTERRUPT MASK**

(Register 0x19h, Reset Value: 0x00, Type: Read/Write)

BITS	NAME	SIZE	DESCRIPTION
7:3	Reserved	5	Do not use
2	Audio jack detection and configuration	1	1: Mask Audio jack detection and configuration has occurred interrupt
1	Low resistance occurred	1	1: Low resistance has occurred interrupt
0	Low resistance detection	1	1: Low resistance detection has occurred interrupt

**Table 28, AUDIO JACK DETECTION REG1 VALUE**

(Register 0x1Ah, Reset Value: 0xFF, Type: Read)

BITS	NAME	SIZE	DESCRIPTION
7:0	Audio jack detection value	8	Resistance between SBU1 to SBU2

**Table 29, AUDIO JACK DETECTION REG2 VALUE**

(Register 0x1Bh, Reset Value: 0xFF, Type: Read)

BITS	NAME	SIZE	DESCRIPTION
7:0	Audio jack detection value	8	Resistance between SBU2 to SBU1

**Table 30, MIC DETECTION THRESHOLD DATA0**

(Register 0x1Ch, Reset Value: 0x20, Type: Read/Write)

BITS	NAME	SIZE	DESCRIPTION
7:0	MIC detection threshold DATA0	8	MIC detection threshold DATA0 00100000: 300mV

**Table 31, MIC DETECTION THRESHOLD DATA1**

(Register 0x1Dh, Reset Value: 0xFF, Type: Read/Write)

BITS	NAME	SIZE	DESCRIPTION
7:0	MIC detection threshold DATA1	8	MIC detection threshold DATA1 11111111: 2400mV

**Table 32, I2C RESET**

(Register 0x1Eh, Reset Value: 0x00, Type: Write/Clear)

BITS	NAME	SIZE	DESCRIPTION
7:1	Reserved	7	Do not use
0	I2C Reset	1	0: default 1: I2C reset

**Table 33, CURRENT SOURCE SETTING**

(Register 0x1Fh, Reset Value: 0x07, Type: Read/Write)

BITS	NAME	SIZE	DESCRIPTION
7:4	Reserved	4	Do not use
3:0	Current Source Setting	4	1111: 1500μA 0111: 700μA ... 0001: 100μA 0000: Invalid

## TEST CIRCUITS

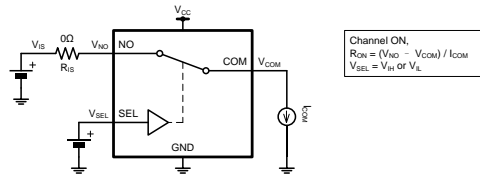

Figure 8, ON Resistance ( $R_{ON}$ )

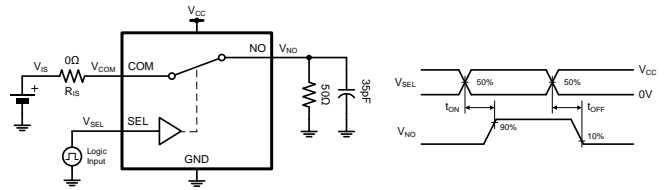

Figure 9, Turn-On and Turn-Off Time ( $t_{ON}/t_{OFF}$ )

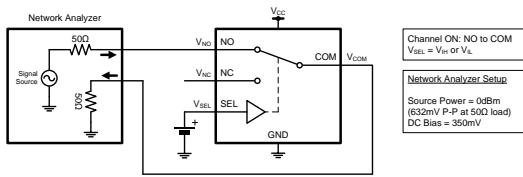

Figure 10, ON Channel -3dB Bandwidth (BW)

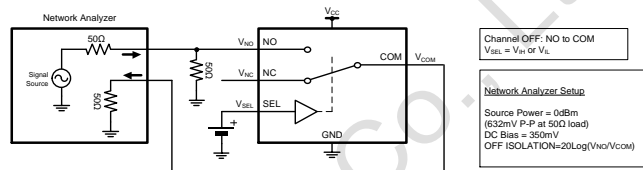

Figure 11, OFF Isolation ( $O_{iso}$ )

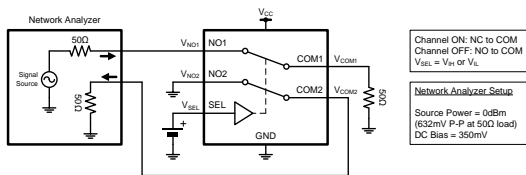

Figure 12, Channel-to-Channel Crosstalk ( $X_{TALK}$ )

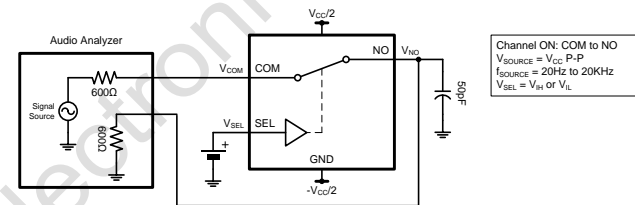
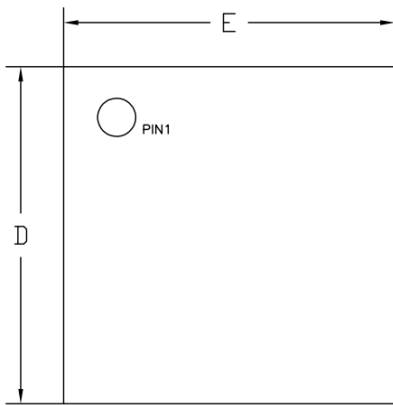
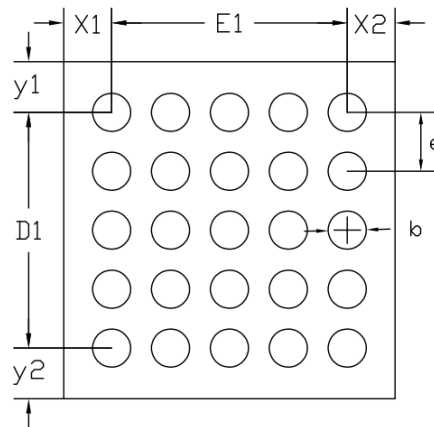

Figure 13, Total Harmonic Distortion (THD+N)

## PACKAGE OUTLINE (CSP25-2.28x2.24)



TOP VIEW  
(MARK SIDE)



BOTTOM VIEW  
(BALL SIDE)

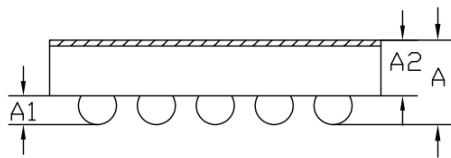

SIDE VIEW

COMMON DIMENSIONS  
(UNITS OF MEASURE=MILLIMETER)

SYMBOL	MIN	NOM	MAX
A	0.529	0.574	0.619
A1	0.176	0.196	0.216
A2	0.353	0.378	0.403
D	2.2582	2.2882	2.3182
D1	1.600BSC		
E	2.2182	2.2482	2.2782
E1	1.600BSC		
b	0.240	0.260	0.280
e	0.400BSC		
x1	0.3241 REF		
x2	0.3241 REF		
y1	0.3441 REF		
y2	0.3441 REF		

Wuxi Grand Microelect

## TAPE AND REEL INFORMATION

### REEL

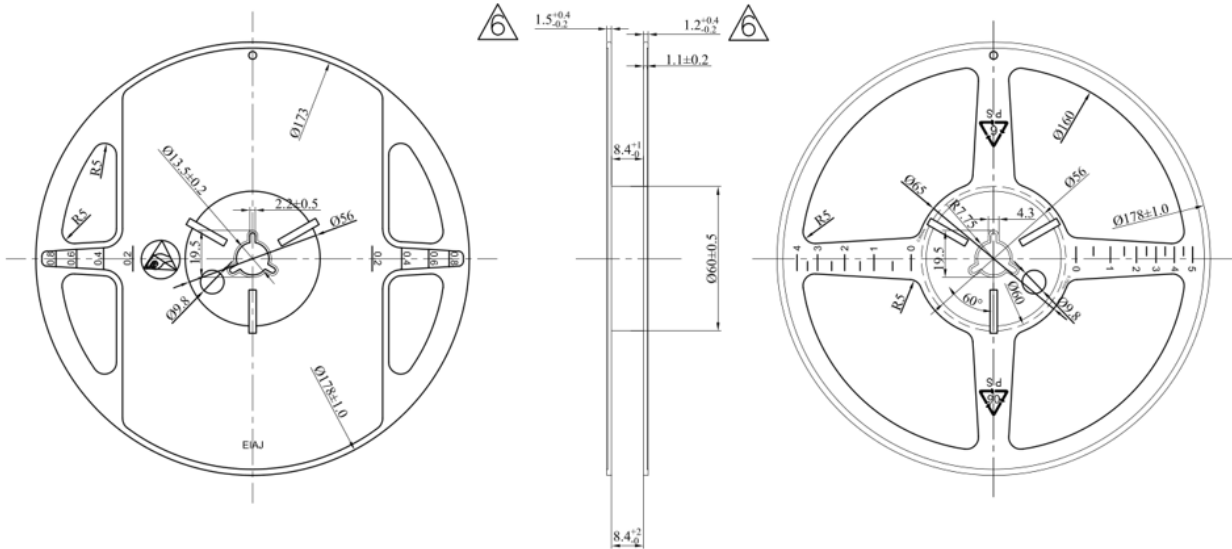

注意：

1. 材料：聚苯乙烯（黑色）；
2. 平整度：最大允许2毫米； $\triangle 4$
3. 所有尺寸为毫米；
- $\triangle 5$  4. 表面电阻： $10^5$  TO  $10^{10}$  OHMS/SQ.
5. 所有未注公差： $\pm 0.25$ 。

### TAPE

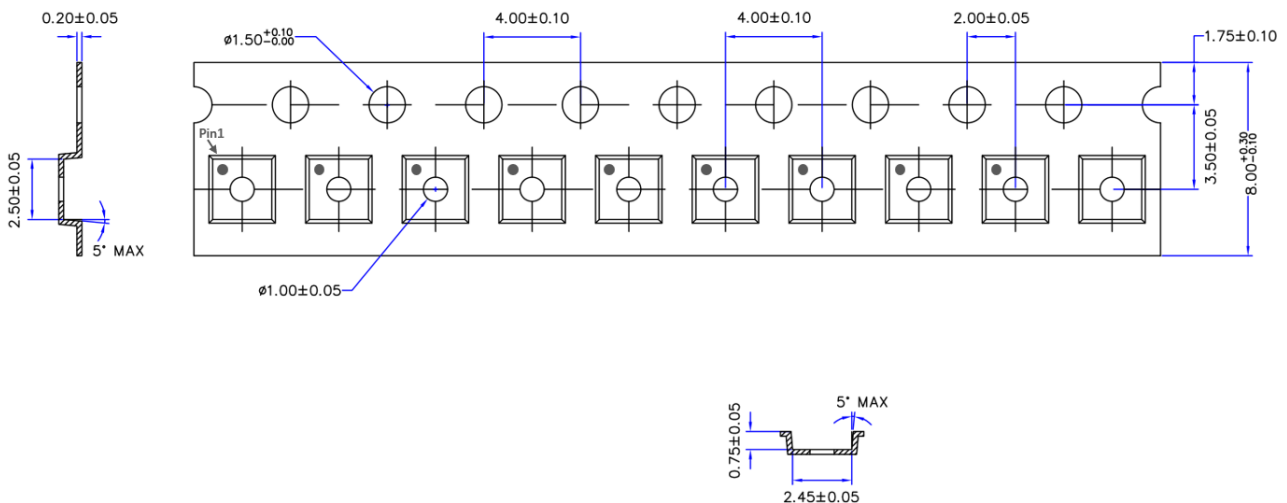

NOTES:

1. ALL DIMS IN MM
2. MATERIAL: BLACK CONDUCTIVE PC
3. 10 sprocket hole pitch cumulative tolerance  $\pm 0.20$ mm
4. Carrier camber is within 1mm in 250mm
5. There must not be foreign body adhesion and the state of the surface must be excellent
6. Surface resistance  $1 \times 10^4 \leq R_s < 1 \times 10^9$  OHMS/SQ
7. 17" PLASTIC-Reel, 121250 pockets (485m)

## 产品订购信息

器件编号	产品丝印	工作温度范围	封装信息	湿敏等级	包装方法
ASW5480WLG	A80 YYWW(*)	-40°C 至 +85°C	WLCSP25-2.28x2.24	MSL-3	卷带和卷盘 (每卷 3000 只)

注：(\*) YY 表示年号，WW 表示周号。