

**Features**

- 18 dB Gain at 2000 MHz
- 32.5 dBm P1dB
- 49 dBm Output IP3
- MTTF > 100 Years
- Two Power Supplies

**Description**

The ASX621, a power amplifier MMIC, has a high linearity, high gain, and high efficiency over a wide range of frequency, being suitable for use in both receiver and transmitter of telecommunication systems up to 3 GHz. The amplifier is available in an SOIC-8 package and passes through the stringent DC, RF, and reliability tests.



Package Style: SOIC-8

**Typical Performance\***

Parameters	Units	Typical							
		900	2000	2450	900	2000	2450	2700	
Frequency	MHz	900	2000	2450	900	2000	2450	2700	
Gain	dB	30	18	13	30	18	13	16	
S11	dB	-17	-14	-9	-17	-14	-9	-12	
S22	dB	-7.5	-14	-10	-7.5	-14	-10	-15	
Output IP3 <sup>1)</sup>	dBm	45	47	46	48	49	48	48	
Noise Figure	dB	11	5.5	6.8	11.5	5.6	7	5.9	
Output P1dB	dBm	32	31.5	32	33	32.5	33	33	
Supply Current	mA	930			1150				
Supply Voltage	V	4.6			5				

\* Performance tested at 50 Ω system and a room temperature.

1) OIP3 measured with two tones at an output power of +14 dBm/tone separated by 1 MHz.

**Product Specifications\***

Parameters	Units	Min	Typ	Max
Testing Frequency	MHz		2000	
Gain	dB	17	18	
S11	dB		-14	
S22	dB		-14	
Output IP3	dBm	47	49	
Noise Figure	dB		5.6	6
Output P1dB	dBm	31.5	32.5	
Supply Current	mA	1050	1150	1250
Supply Voltage	V		5	

\* 100% in-house DC & RF testing is done on packaged products before taping.

**Absolute Maximum Ratings**

Parameters	Rating
Operating Case Temperature	-40 to +85°C
Storage Temperature	-40 to +150°C
Supply Voltage	+6 V
Operating Junction Temperature	+150°C
Input RF Power (CW, 50ohm matched)*	25 dBm

\* Please find the max. input power data from [http://www.asb.co.kr/pdf/Maximum\\_Input\\_Power\\_Analysis.pdf](http://www.asb.co.kr/pdf/Maximum_Input_Power_Analysis.pdf)

**Applications**

- CDMA, GSM, W-CDMA, PCS
- Gain Block
- CATV Amplifier
- IF Amplifier
- WiBro Amplifier
- Bluetooth Amplifier
- Wireless LAN Amplifier

**More Information**

Tel: (82) 42-528-7223

Fax: (82) 42-528-7222

ASB Inc., 4<sup>th</sup> Fl. Venture Town Bldg.,  
367-17 Gojeong-Dong, Seo-Gu,  
Daejeon 302-716, Korea

# ASX621

## DC-3000 MHz MMIC Amplifier

**APPLICATION CIRCUIT**

---

**CDMA Rx**

---

**824 ~ 849**

---

**+5 V**

Frequency (MHz)	824~849
Magnitude S21 (dB)	28
Magnitude S11 (dB)	-14
Magnitude S22 (dB)	-8
Output P1dB (dBm)	32.5
Output IP3 <sup>1)</sup> (dBm)	47
Noise Figure (dB)	11
Supply Voltage (V)	5
Current (mA)	1150

1) OIP3 is measured with two tones at an output power of +15 dBm/tone separated by 1 MHz.

### Schematic

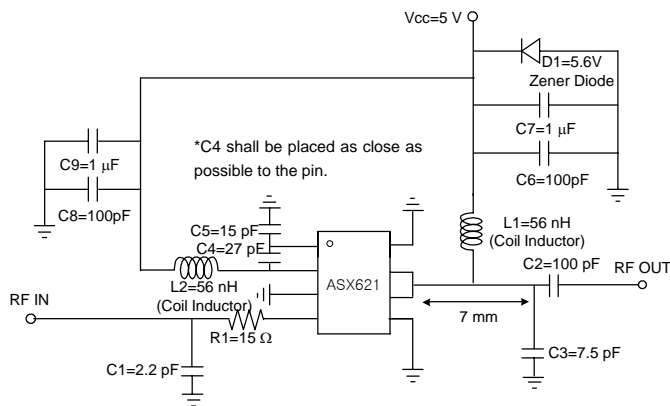

### Board Layout (FR4, 40x40 mm<sup>2</sup>, 0.8T)

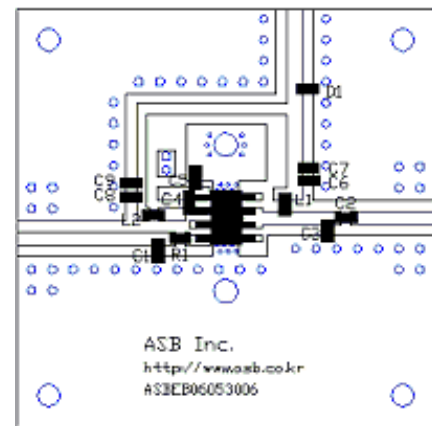

### S-parameters

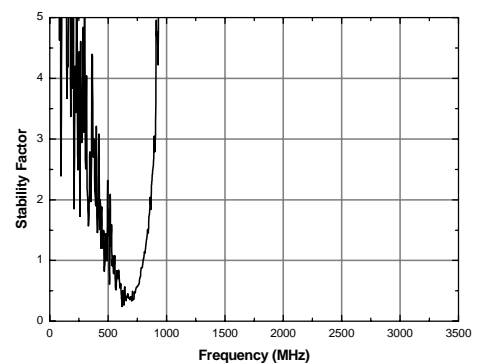
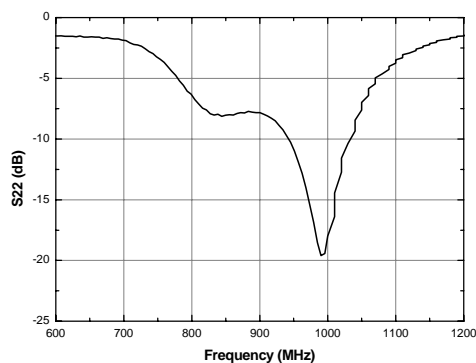
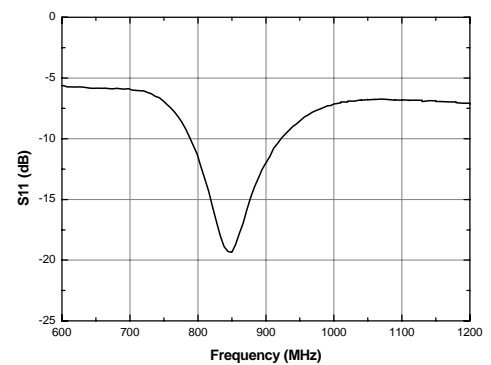
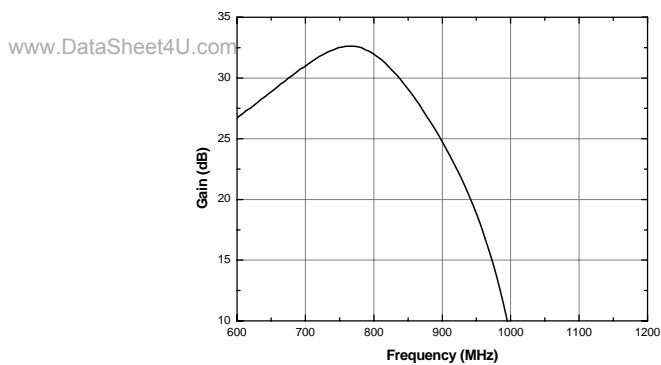

# ASX621

## DC-3000 MHz MMIC Amplifier

**APPLICATION CIRCUIT**

---

**CDMA Tx, GSM**

---

**869 ~ 960**

---

**+5 V**

---

Frequency (MHz)	869	960
Magnitude S21 (dB)	31	26
Magnitude S11 (dB)	-13	-18
Magnitude S22 (dB)	-8	-7.5
Output P1dB (dBm)	32.5	32.5
Output IP3 <sup>1)</sup> (dBm)	47	48
Noise Figure (dB)	11	11
Supply Voltage (V)	5	5
Current (mA)	1150	1150

1) OIP3 is measured with two tones at an output power of +15 dBm/tone separated by 1 MHz.

### Schematic

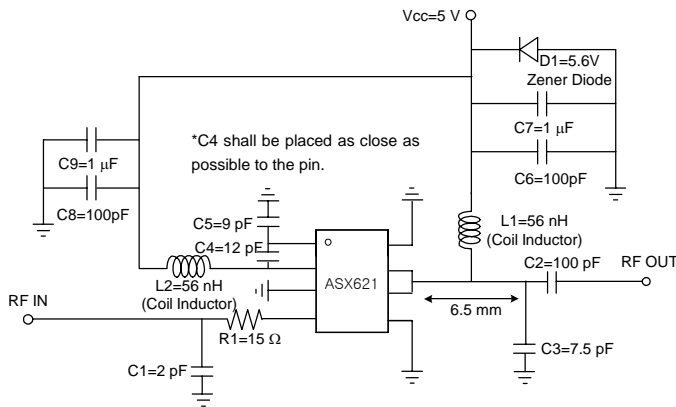

### Board Layout (FR4, 40x40 mm<sup>2</sup>, 0.8T)

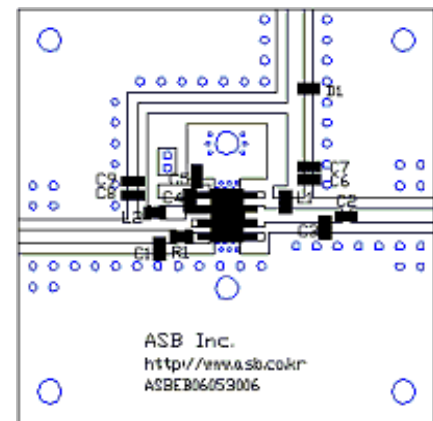

### S-parameters

www.DataSheet4U.com

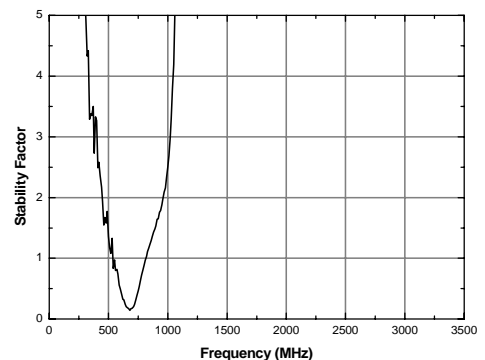
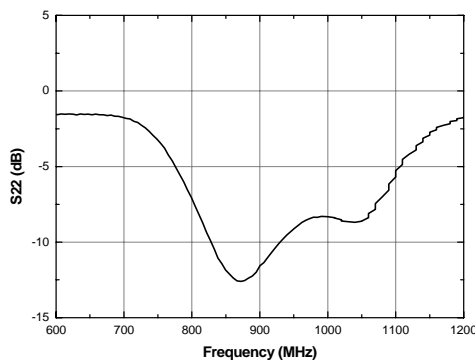
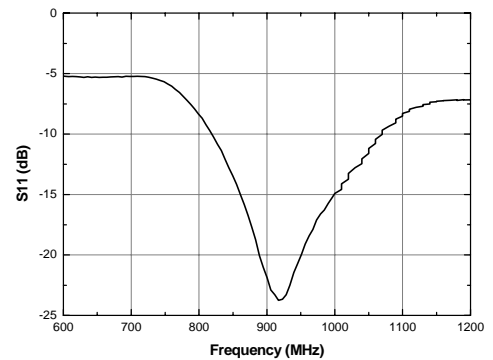
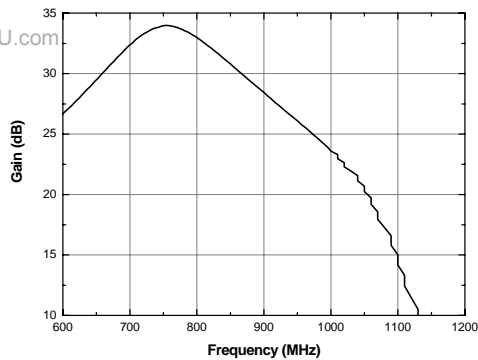

# ASX621

## DC-3000 MHz MMIC Amplifier

**APPLICATION CIRCUIT**

---

**WCDMA Rx**

---

**1920 ~ 1980**

---

**+5 V**

---

Frequency (MHz)	1920~1980
Magnitude S21 (dB)	18
Magnitude S11 (dB)	-14
Magnitude S22 (dB)	-14
Output P1dB (dBm)	32.5
Output IP3 <sup>1)</sup> (dBm)	50
Noise Figure (dB)	5.6
Supply Voltage (V)	5
Current (mA)	1150

1) OIP3 is measured with two tones at an output power of +14 dBm/tone separated by 1 MHz.

### Schematic

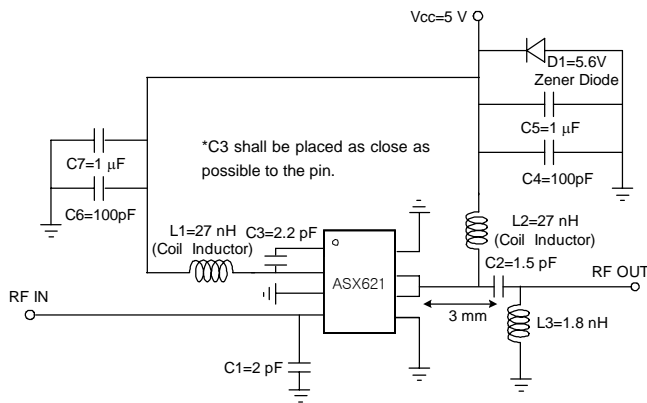

### Board Layout (FR4, 40x40 mm<sup>2</sup>, 0.8T)

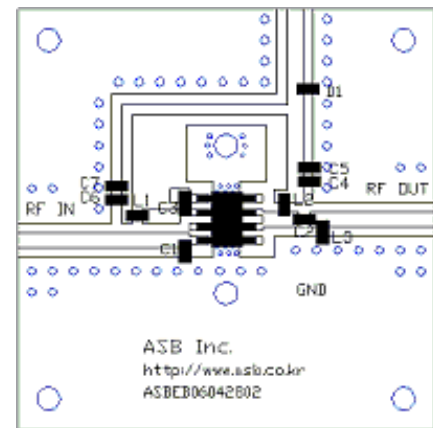

### S-parameters

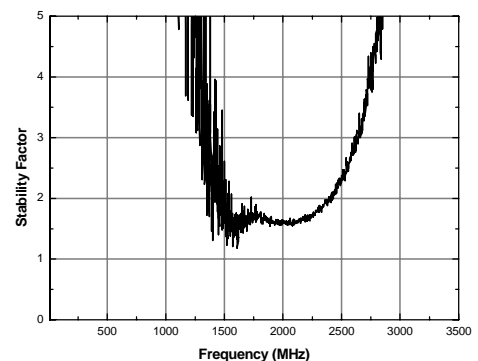
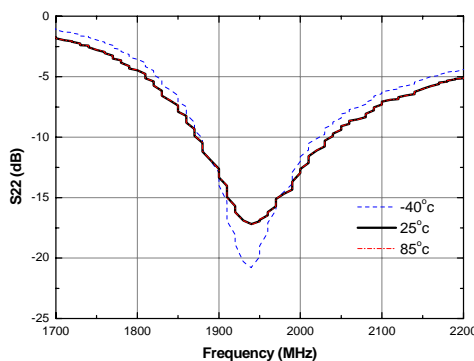
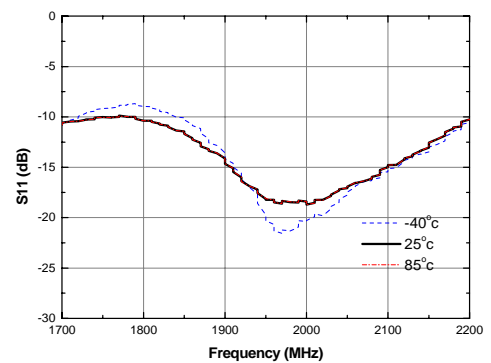
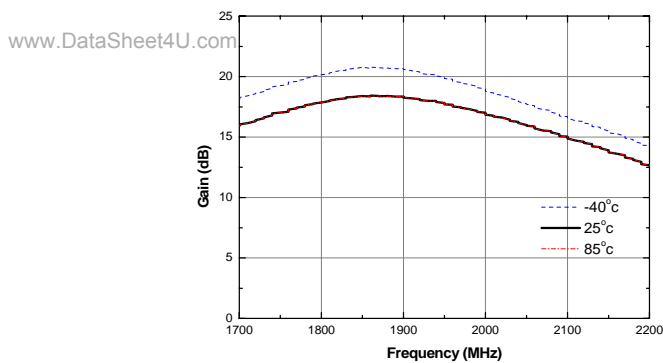

# ASX621

## DC-3000 MHz MMIC Amplifier

**Current vs. Temperature**

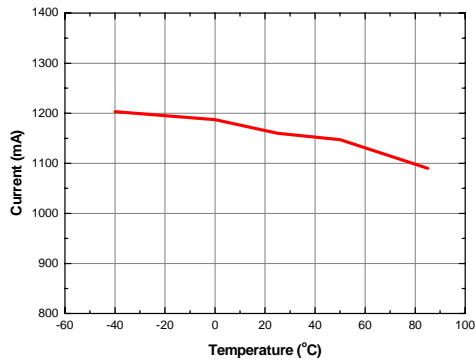

**Gain vs. Temperature**

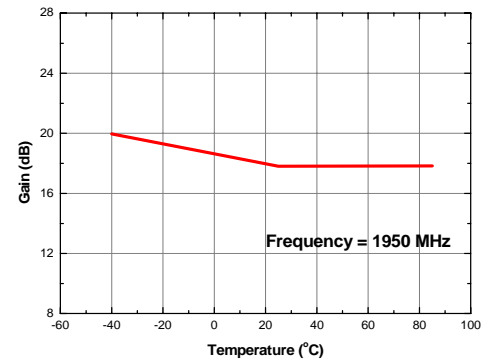

**P1dB vs. Temperature**

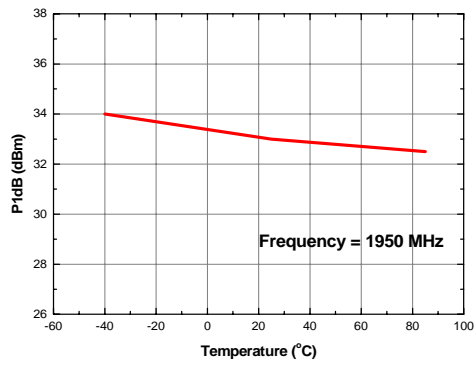

**Output IP3 vs. Tone Power (Frequency = 1950 MHz)**

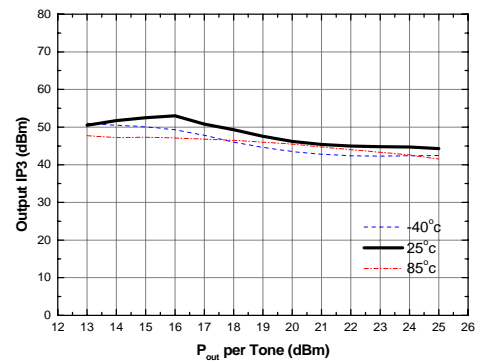

# ASX621

## DC-3000 MHz MMIC Amplifier

**APPLICATION CIRCUIT**

---

**WCDMA Tx**

---

**2110 ~ 2170**

---

**+5 V**

Frequency (MHz)	2110~2170
Magnitude S21 (dB)	17
Magnitude S11 (dB)	-15
Magnitude S22 (dB)	-13
Output P1dB (dBm)	32.5
Output IP3 <sup>1)</sup> (dBm)	50
Noise Figure (dB)	5.6
Supply Voltage (V)	5
Current (mA)	1150

1) OIP3 is measured with two tones at an output power of +14 dBm/tone separated by 1 MHz.

### Schematic

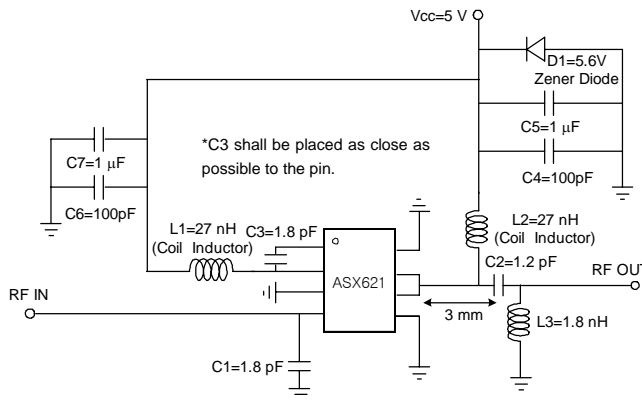

### Board Layout (FR4, 40x40 mm<sup>2</sup>, 0.8T)

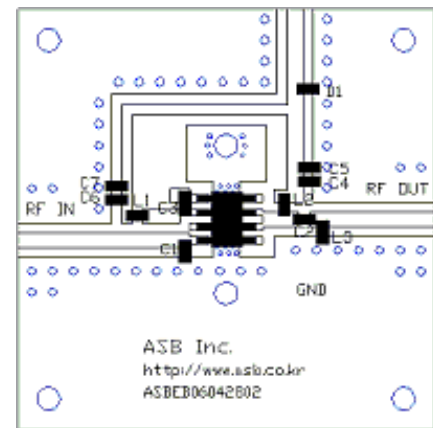

### S-parameters

www.DataSheet4U.com

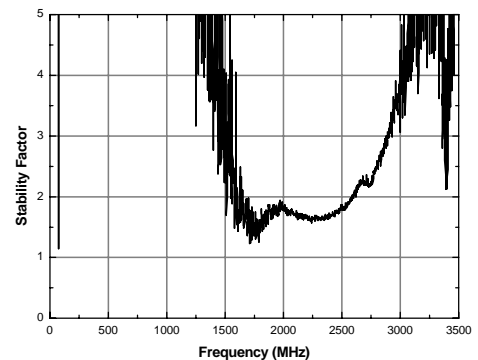
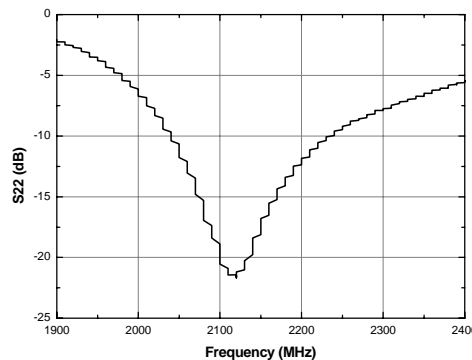
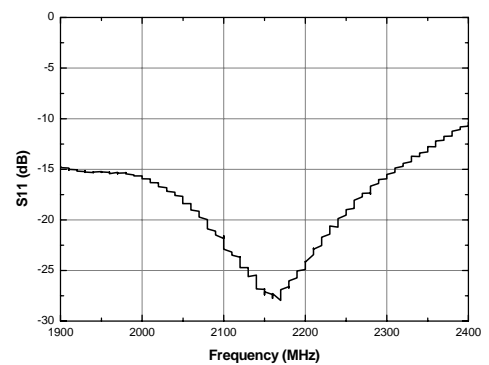
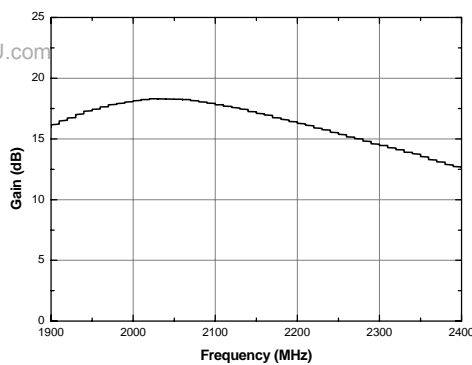

# ASX621

## DC-3000 MHz MMIC Amplifier

**APPLICATION CIRCUIT**

---

**WLAN**

---

**2400 ~ 2500**

---

**+5 V**

---

Frequency (MHz)	2400~2500
Magnitude S21 (dB)	13
Magnitude S11 (dB)	-9
Magnitude S22 (dB)	-10
Output P1dB (dBm)	33
Output IP3 <sup>1)</sup> (dBm)	48
Noise Figure (dB)	7
Supply Voltage (V)	5
Current (mA)	1150

1) OIP3 is measured with two tones at an output power of +14 dBm/tone separated by 1 MHz.

### Schematic

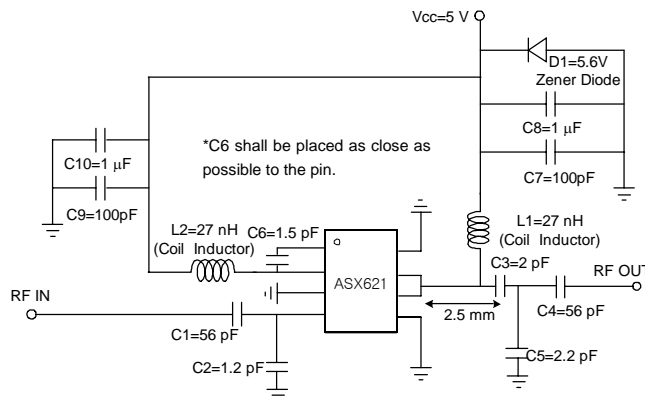

### Board Layout (FR4, 40x40 mm<sup>2</sup>, 0.8T)

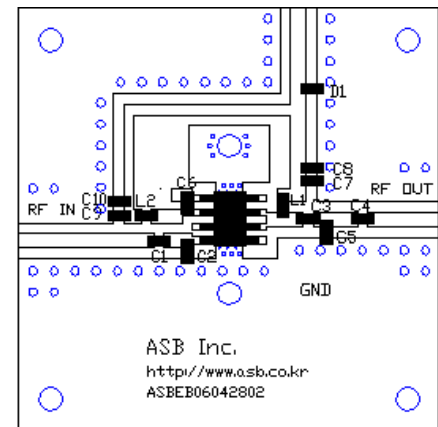

### S-parameters

www.DataSheet4U.com

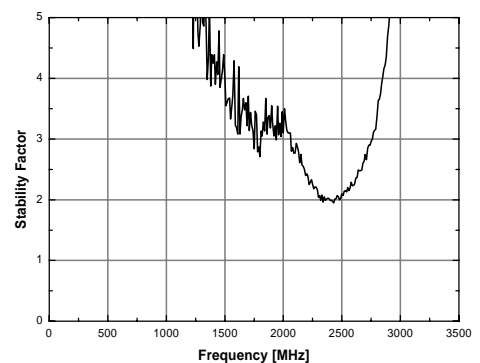
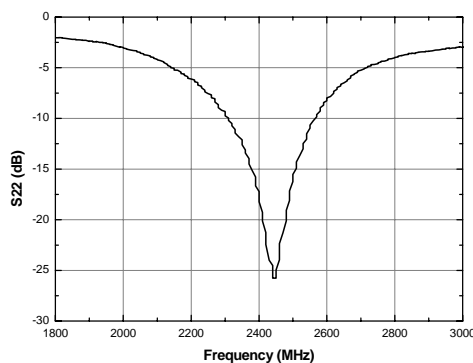
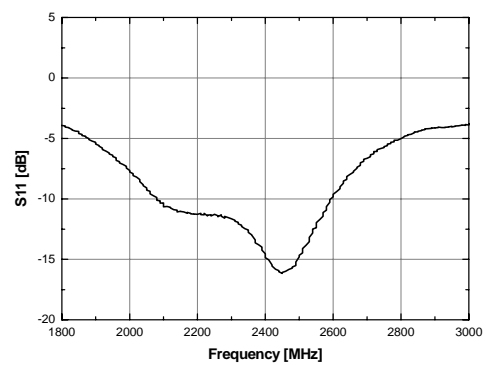
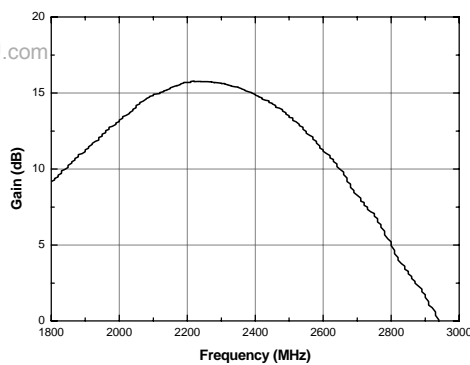

# ASX621

## DC-3000 MHz MMIC Amplifier

**APPLICATION CIRCUIT**

---

**WiMAX**

---

**2700 ~ 2900**

---

**+5 V**

---

Frequency (MHz)	2700	2900
Magnitude S21 (dB)	16	14
Magnitude S11 (dB)	-12	-12
Magnitude S22 (dB)	-15	-15
Output P1dB (dBm)	33	
Output IP3 <sup>1)</sup> (dBm)	48	
Noise Figure (dB)	5.9	
Supply Voltage (V)	5	
Current (mA)	1150	

1) OIP3 is measured with two tones at an output power of +15 dBm/tone separated by 1 MHz.

### Schematic

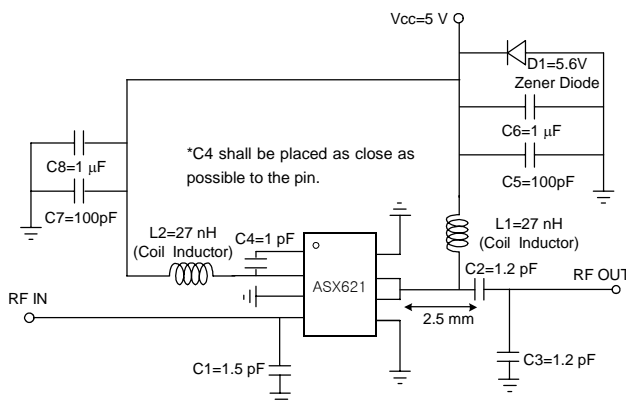

### Board Layout (FR4, 40x40 mm<sup>2</sup>, 0.8T)

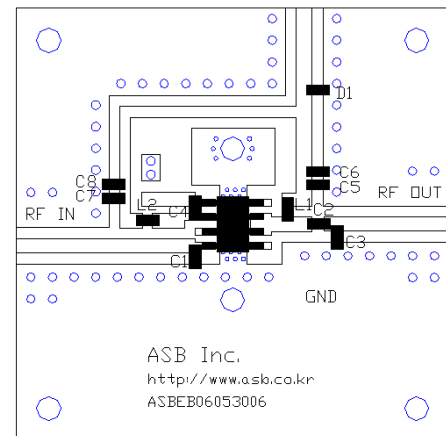

### S-parameters

www.DataSheet4U.com

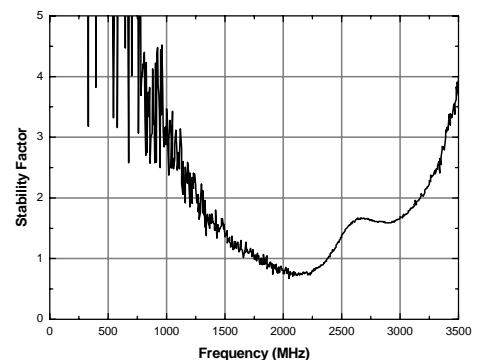
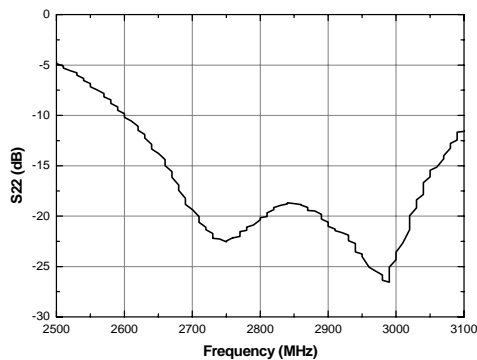
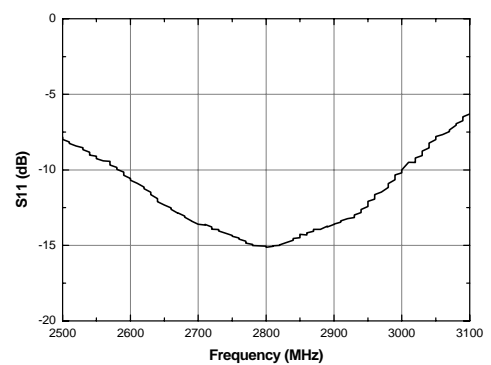
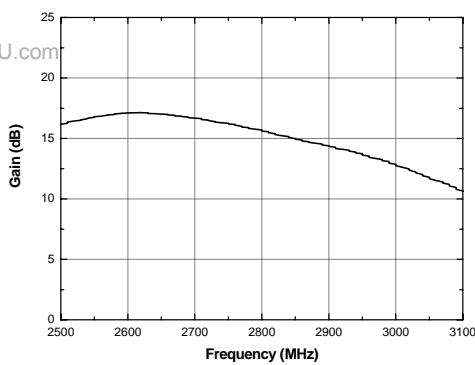



# ASX621

## DC-3000 MHz MMIC Amplifier

**APPLICATION CIRCUIT**

---

**1200 ~ 1400**

---

**+5 V**

---

Frequency (MHz)	1200	1300	1400
Magnitude S21 (dB)	25.5	23	20
Magnitude S11 (dB)	-14	-12	-7
Magnitude S22 (dB)	-10	-9	-7
Output P1dB (dBm)	31	32.5	31
Output IP3 <sup>1)</sup> (dBm)	48	48	47
Noise Figure (dB)	9.5	9.5	9.5
Supply Voltage (V)	5	5	5
Current (mA)	1150	1150	1150

1) OIP3 is measured with two tones at an output power of +14 dBm/tone separated by 1 MHz.

### Schematic

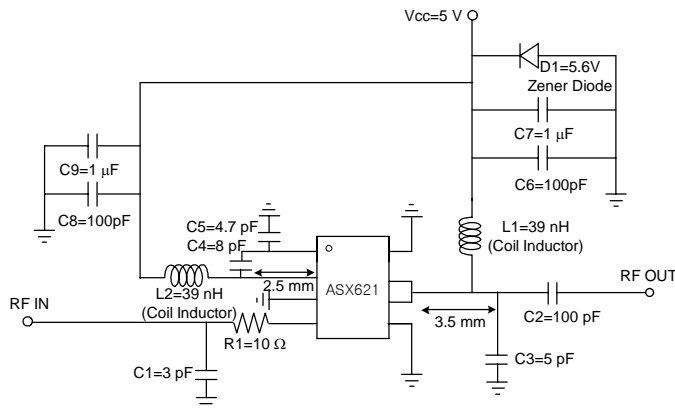

### Board Layout (FR4, 40x40 mm<sup>2</sup>, 0.8T)

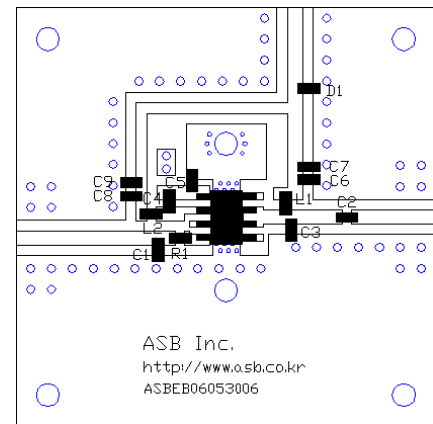

### S-parameters

www.DataSheet4U.com

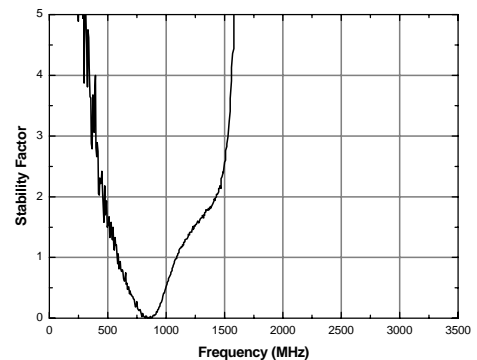
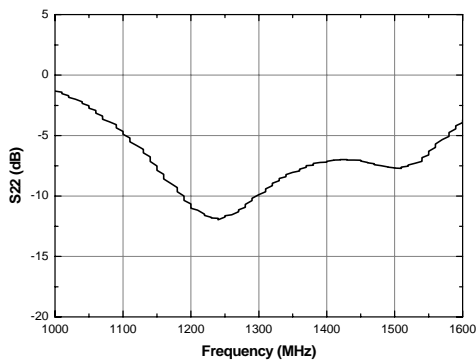
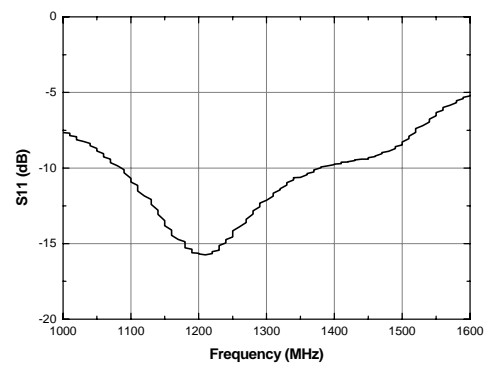
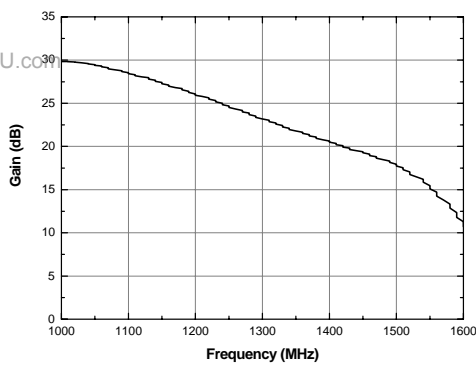

# ASX621

## DC-3000 MHz MMIC Amplifier

### Outline Drawing

(Unit: mm)

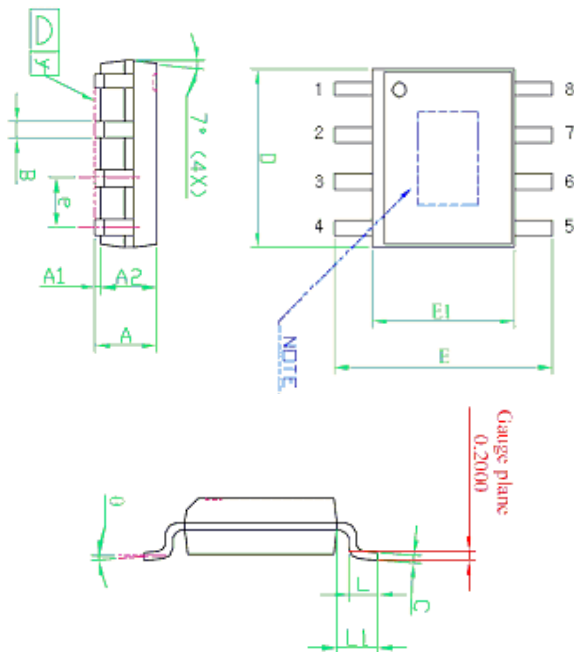

Symbols	Dimensions (In mm)		
	MIN	NOM	MAX
A	1.40	1.50	1.60
A1	0.00	--	0.10
A2	--	1.45	--
B	0.33	--	0.51
C	0.19	--	0.25
D	4.80	--	5.00
E1	3.80	3.90	4.00
e	--	1.27	--
E	5.80	6.00	6.20
L	0.40	--	1.27
y	--	--	0.10
θ	0°	--	8°
L1	0.95	1.05	1.15

Pin No.	Function	Pin No.	Function.
1	2nd stage RF IN	5	GND
2	1st stage RF OUT	6	2nd stage RF OUT
3	GND	7	2nd stage RF OUT
4	1st stage RF IN	8	GND

### Mounting Recommendation (in mm)

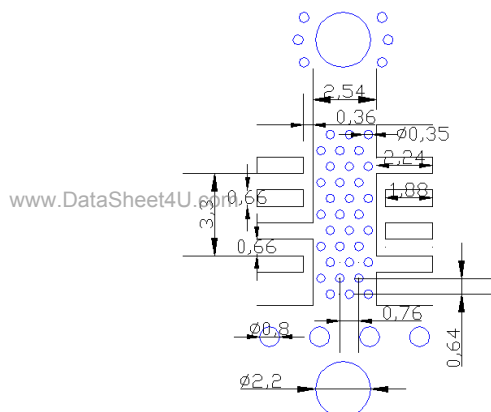

- Note:
1. Add as much copper as possible to inner and outer layers near the part to ensure optimal thermal performance.
  2. To ensure reliable operation, device ground paddle-to-ground pad soldering is critical.
  3. Add mounting screws near the part to fasten the board to a heat sink. Ensure that the ground / thermal via region contacts the heat sink.
  4. A proper heat dissipation path underneath the area of the PCB for the mounted device is strictly required for proper thermal operation. Damage to the device can result from inappropriate heat dissipation.

### ESD Classification

HBM	Class 1B
	Voltage Level: 500 V~1000 V
MM	Class A
	Voltage Level: <200 V

CAUTION: ESD-sensitive device!

### Moisture Sensitivity Level (MSL)

Level 3 at 260°C reflow