

# **INNOLUX DISPLAY CORPORATION**

LCD MODULE

## **SPECIFICATION**

Customer: \_\_\_\_\_

Model Name: AT070TN03

SPEC NO: A07003T01

Date: Dec, 2003

Version: 1.0

Preliminary Specification

Final Specification

For Customer's Acceptance

Approved by	Comment

Approved by	Reviewed by	Prepare by

InnoLux copyright 2003 All rights reserved, Copying forbidden.

InnoLux Display Corporation,

2F, No.16, Ke-Tung Road 3, Science-Based Industrial Park, Chu-Nan 350, Mao-Li County,  
Taiwan

Tel: 886-37-586000

Fax: 886-37-586060

## Revisions Section

Revision	Description	Date
1	Initial Release	2003/12/28
2	Display quality specification change	2004/02/06

**Contents:**

<b>1. General specification.....</b>	<b>3</b>
<b>2. Electrical specifications.....</b>	<b>3</b>
(1). Absolute maximum ratings	
(2). Pin assignment	
(a). TFT LCD panel driving section	
(b). Backlight Unit	
(3). Electrical characteristics	
(a). Typical operating conditions	
(b). Current consumption	
(c). Backlight driving conditions	
(4). AC timing	
(a). Timing conditions	
(b). Timing diagram	
<b>3. Optical specifications.....</b>	<b>12</b>
<b>4. Reliability test Items.....</b>	<b>14</b>
<b>5. Handling precautions.....</b>	<b>14</b>
(1). Safety	
(2). Handling	
(3). Static electricity	
(4). Storage	
(5). Cleaning	
<b>6. Mechanical dimensions.....</b>	<b>15</b>

**7. Packing form..... 17**

**1. General specifications**

NO.	Item	Specification	Remark
1	LCD size	7.0 inch	
2	Driver Element	a-Si TFT active matrix	
3	Display contents	480 pixels X 234 pixels	
4	Display Mode	Normally white, Transmissive with Backlight	
5	Dot pitch	0.107(W) X 0.370(H) mm	
6	Active area	154.08(W) X 86.58(H) mm	
7	Module Size	164.9 X 100 X 5.7 mm	
8	Surface Treatment	AG	
9	Weight	160 g Typical	

**2. Electrical characteristics****(1). Absolute maximum ratings**

Item	Symbol	Condition	Values		Unit	Remark
			Min.	Max.		
Power voltage	$V_{CC}$	GND=0	(-0.3)	(7)	V	
	$AV_{DD}$	$AV_{SS}=0$	(-0.3)	(7)	V	
	$V_{GH}$	GND=0	(-0.3)	(18)	V	
	$V_{GL}$		(-15)	(0.3)	V	
	$V_{GH} - V_{GL}$		-	(33)	V	
Input signal voltage	$V_i$		(-0.3)	$AV_{DD}+0.3$	V	Note 1
	$V_I$		(-0.3)	$V_{CC}+0.3$	V	Note 2
	VCOM		(-2.9)	(5.2)	V	
Operation Temperature (Ambient)	Top		-10	60	°C	
Storage Temperature (Ambient)	Tst		-20	70	°C	

Note:

- VR, VG, VB.
- STHL, STHR, OEH, L/R, CPH1~CPH3, STVR, STVL, OEV, CKV, U/D.

**(2). Pin assignment****(a). TFT LCD panel diving section**

Pin no	Symbol	IO	Function	Remark
1	GND	-	Ground for logic circuit	
2	$V_{CC}$	I	Supply voltage of logic control circuit for scan driver	
3	$V_{GL}$	I	Negative power for scan driver	

4	$V_{GH}$	I	Positive power for scan driver	
5	STVR	I/O	Vertical start pulse	Note 1
6	STVL	I/O	Vertical start pulse	Note 1
7	CKV	I	Shift clock input for scan driver	
8	U/D	I	UP/DOWN scan control input	Note 1,2
9	OEV	I	Output enable control for scan driver	
10	VCOM	I	Common electrode driving signal	
11	VCOM	I	Common electrode driving signal	
12	L/R	I	LEFT/RIGHT scan control	Note 1,2
13	MOD	I	Sequential sampling and simultaneous sampling setting	Note 3
14	OEH	I	Output enable control for data driver	
15	STHL	I/O	Start pulse for horizontal scan line	Note 1
16	STHR	I/O	Start pulse for horizontal scan line	Note 1
17	CPH3	I	Sampling and shifting clock pulse for data driver	
18	CPH2	I	Sampling and shifting clock pulse for data driver	
19	CPH1	I	Sampling and shifting clock pulse for data driver	
20	$V_{CC}$	I	Supply voltage of logic control circuit for data driver	
21	GND	-	Ground for logic circuit	
22	VR	I	Alternated video signal (Red)	
23	VG	I	Alternated video signal (Green)	
24	VB	I	Alternated video signal (Blue)	
25	$AV_{DD}$	I	Supply voltage for analog circuit	
26	$AV_{SS}$	-	Ground for analog circuit	

Note:

1. Selection of scanning mode (please refer to the following table)

Setting of scan control input		IN/OUT state for start pulse				Scanning direction
U/D	L/R	STVR	STVL	STHR	STHL	
GND	$V_{CC}$	O	I	O	I	Up to down, left to right
$V_{CC}$	GND	I	O	I	O	Down to up, right to left
GND	GND	O	I	I	O	Up to down, right to left
$V_{CC}$	$V_{CC}$	I	O	O	I	Down to up, left to right

I: input, O: output

## 2. Definition of Scanning Direction.

Refer to figure as below:

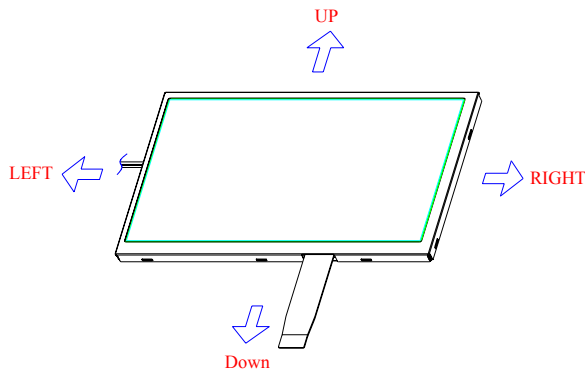

## 3. MOD=H: Simultaneous sampling.

MOD=L: Sequential sampling.

Please set CPH2 and CPH3 to GND when MOD=H,

## (b). Backlight unit

Pin no	Symbol	Function	Remark
1	HI	Power supply for backlight unit (high voltage)	Pink
2	GND	Ground for backlight unit	White

## (3). Electrical characteristics

(a). Typical operating conditions (GND=AV<sub>SS</sub>=0V, Note 4)

Item	Symbol	Values			Unit	Remark
		Min.	Typ.	Max.		
Power supply	V <sub>CC</sub>	3	5	5.2	V	
	AV <sub>DD</sub>	4.8	5	5.2	V	
	V <sub>GH</sub>	14.3	15	15.7	V	
	V <sub>GL</sub>	-10.5	-10	-9.5	V	
Video signal amplitude (VR, VG, VB)	V <sub>iA</sub>	0.4	-	AV <sub>DD</sub> -0.4	V	Note1
	V <sub>iAC</sub>	-	3	-	V	AC component
	V <sub>iDC</sub>	-	AV <sub>DD</sub> /2	-	V	DC component
VCOM	V <sub>CAC</sub>	3.5	5.6	6.5	V	Note2
	V <sub>CDC</sub>	1.7	2.0	2.3	V	DC component
Input signal Voltage	H level	V <sub>IH</sub>	0.8V <sub>CC</sub>	-	V <sub>CC</sub>	Note3
	L level	V <sub>IL</sub>	0	-	0.2V <sub>CC</sub>	

Note:

1. Refer to Fig.3-(a).
2. The brightness of LCD panel could be changed by adjusting the AC component of VCOM.
3. SRHL, STHR, OEHL, L/R, CPH1~CPH3, STVR, STVL, OEVL, CKV, U/D
4. Be sure to apply GND, V<sub>CC</sub>, and V<sub>GL</sub>, to the LCD first, and then apply V<sub>GH</sub>

(b). Current consumption (GND=AV<sub>SS</sub>=0V)

Parameter	Symbol	Condition	Values			Unit	Remark
			Min.	Typ.	Max.		
Current for Driver	I <sub>GH</sub>	V <sub>GH</sub> =15V		0.2	0.5	mA	
	I <sub>GL</sub>	V <sub>GL</sub> =-10V		0.8	1.5	mA	
	I <sub>CC</sub>	V <sub>CC</sub> =5V		3.0	6.0	mA	
	I <sub>DD</sub>	AV <sub>DD</sub> =5V		17	30	mA	

## (c). Backlight driving conditions

Item	Symbol	Values			Unit	Remark
		Min.	Typ.	Max.		
Lamp voltage	V <sub>L</sub>	-	560	620	Vrms	
Lamp Current	I <sub>L</sub>	-	6	7	mArms	
Frequency	F <sub>L</sub>	-	60	80	kHz	Note 4
Lamp starting voltage	V <sub>S</sub>	-	-	900	Vrms	Note 1,5
		-	-	-	Vrms	Note 2,5
		-	-	1,100	Vrms	Note 3,5
Lamp life time		10,000	-	-	Hr	Note 6

## Note:

1. Ta=25°C
2. Ta=0°C
3. Ta=-20°C
4. The lamp frequency should be selected as different as possible from display horizontal synchronous signal to avoid interference
5. For starting the backlight unit, the output voltage of DC/AC's transformer should be larger than the maximum lamp starting voltage.
6. The "lamp life time" is defined as the module brightness decrease to 50% original brightness at Ta=25°C, I<sub>L</sub>=6mA

## (4). AC timing

## (a). Timing conditions (sequential mode)

Item	Symbol	Values			Unit	Remark
		Min.	Typ.	Max.		
Rising time	t <sub>r</sub>	-	-	10	ns	Note 1
Falling time	t <sub>f</sub>	-	-	10	ns	Note 1
High and low level pulse width	t <sub>CPH</sub>	99	103	107	ns	CPH1~CPH3
CPH pulse duty	t <sub>CWH</sub>	40	50	60	%	CPH1~CPH3
CPH pulse delay	t <sub>C12</sub> t <sub>C23</sub> t <sub>C31</sub>	30	t <sub>CPH</sub> /3	t <sub>CPH</sub> /2	ns	CPH1~CPH3



STH setup time	$t_{SUH}$	20	-	-	ns	STHR, STHL
STH hold time	$t_{HDH}$	20	-	-	ns	STHR, STHL
STH pulse width	$t_{STH}$	-	1	-	$t_{CPH}$	STHR, STHL
STH period	$t_H$	61.5	63.5	65.5	$\mu s$	STHR, STHL
OEH pulse width	$t_{OEH}$	-	1.22	-	$\mu s$	
Sample and hold disable time	$t_{DIS1}$	-	8.28	--	$\mu s$	
OEV pulse width	$t_{OEV}$	-	5.40		$\mu s$	
CKV pulse width	$t_{CKV}$	-	4.18	-	$\mu s$	
Clean enable time	$t_{DIS2}$	-	3.74	--	$\mu s$	
Horizontal display start	$t_{SH}$	-	0	-	$t_{CPH}/3$	
Horizontal display timing range	$t_{DH}$	-	1440	-	$t_{CPH}/3$	
STV setup time	$t_{SUV}$	400	-	-	ns	STVL, STVR
STV hold time	$t_{HDV}$	400	-	-	ns	STVL, STVR
STV pulse width	$t_{STV}$	-	-	1	$t_H$	STVL, STVR
Horizontal lines per field	$t_V$	256	262	268	$t_H$	Note 2
Vertical display start	$t_{SV}$		3	-	$t_H$	
Vertical display timing range	$t_{DV}$		234	-	$t_H$	
VCOM rising time	$t_{rCOM}$		-	5	$\mu s$	
VCOM falling time	$t_{fCOM}$		-	5	$\mu s$	
VCOM delay time	$t_{DCOM}$		-	3	$\mu s$	
RGB delay time	$t_{DRGB}$		-	1	$\mu s$	

Note:

1. For all of the logic signals
2. Please don't use odd horizontal lines to drive LCD panel for both odd and even field simultaneously.

b. Timing diagram

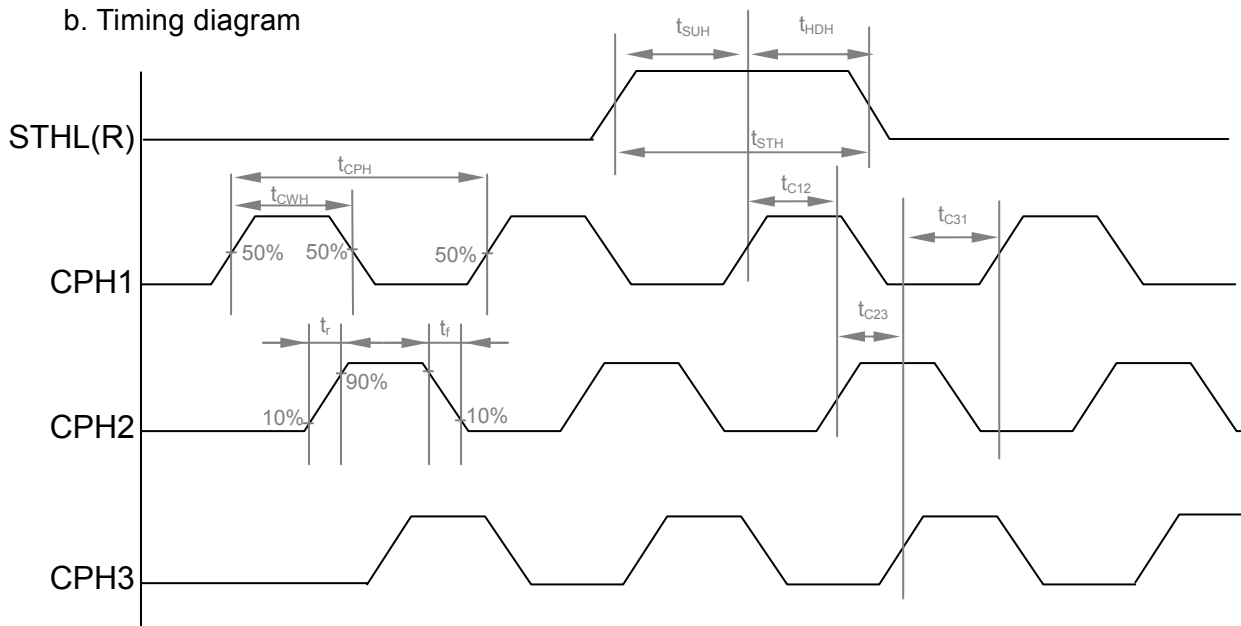

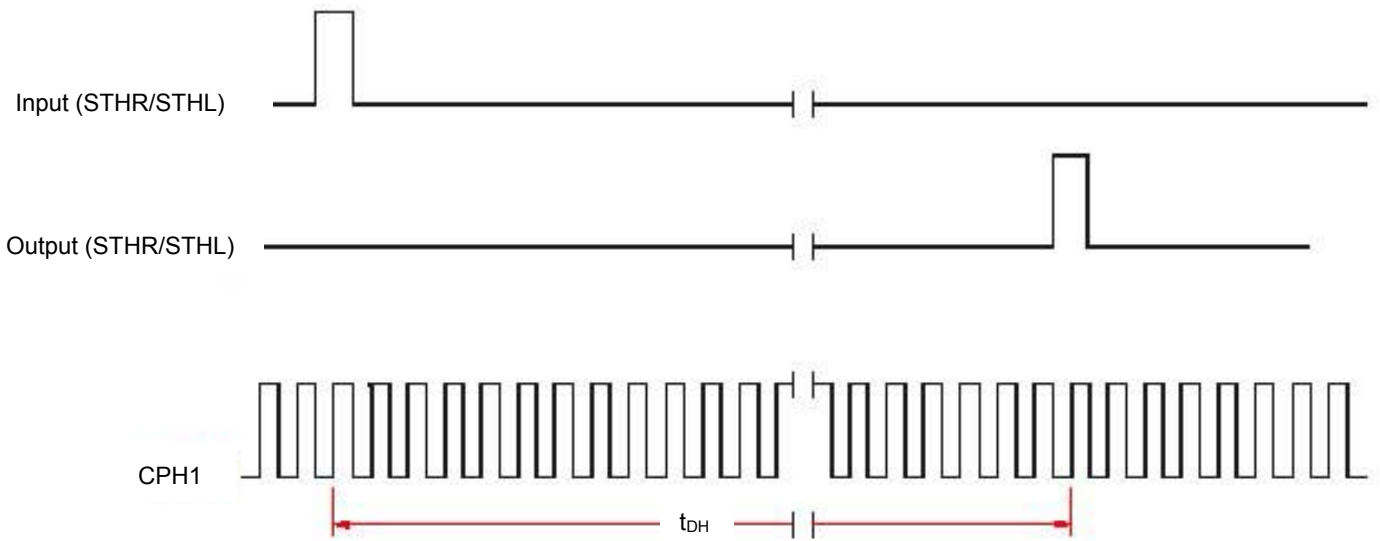

Fig.2 Sampling clock timing

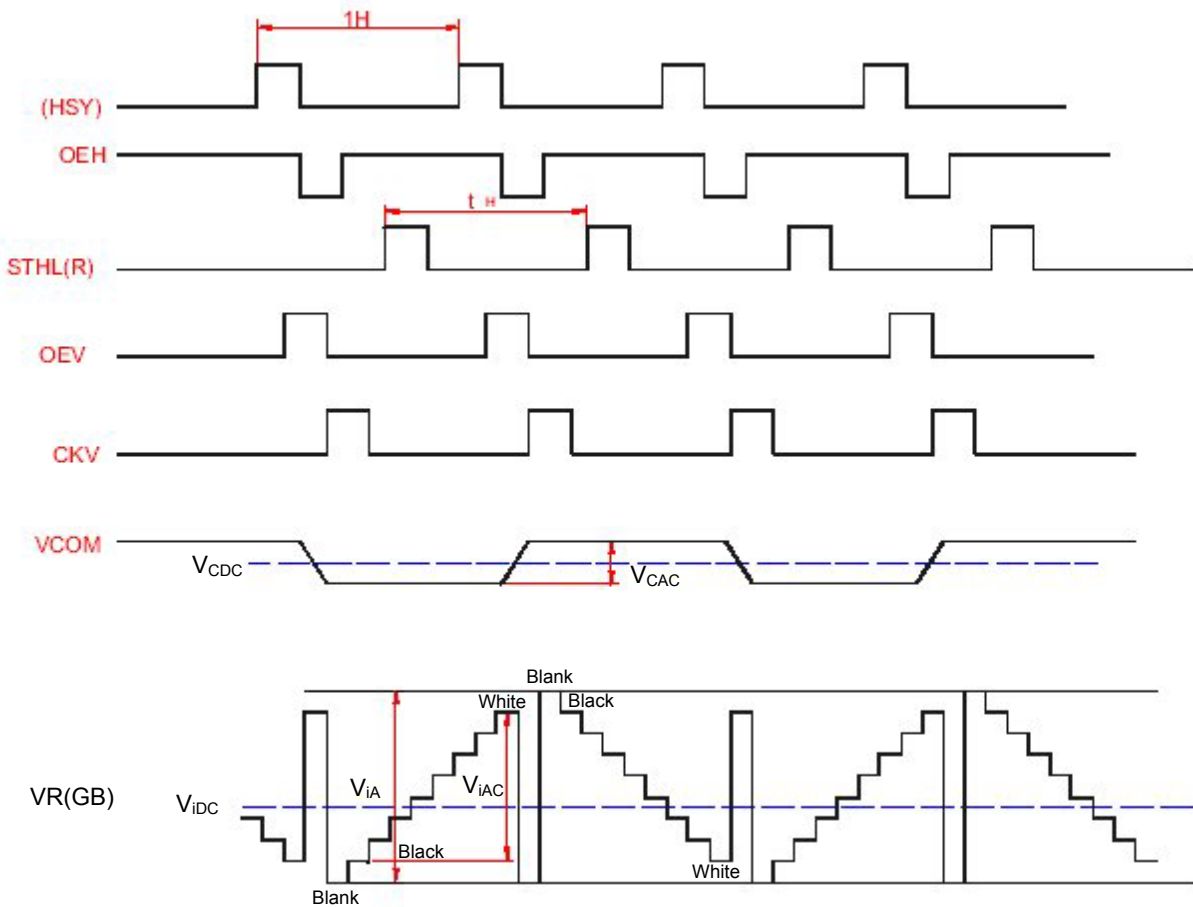
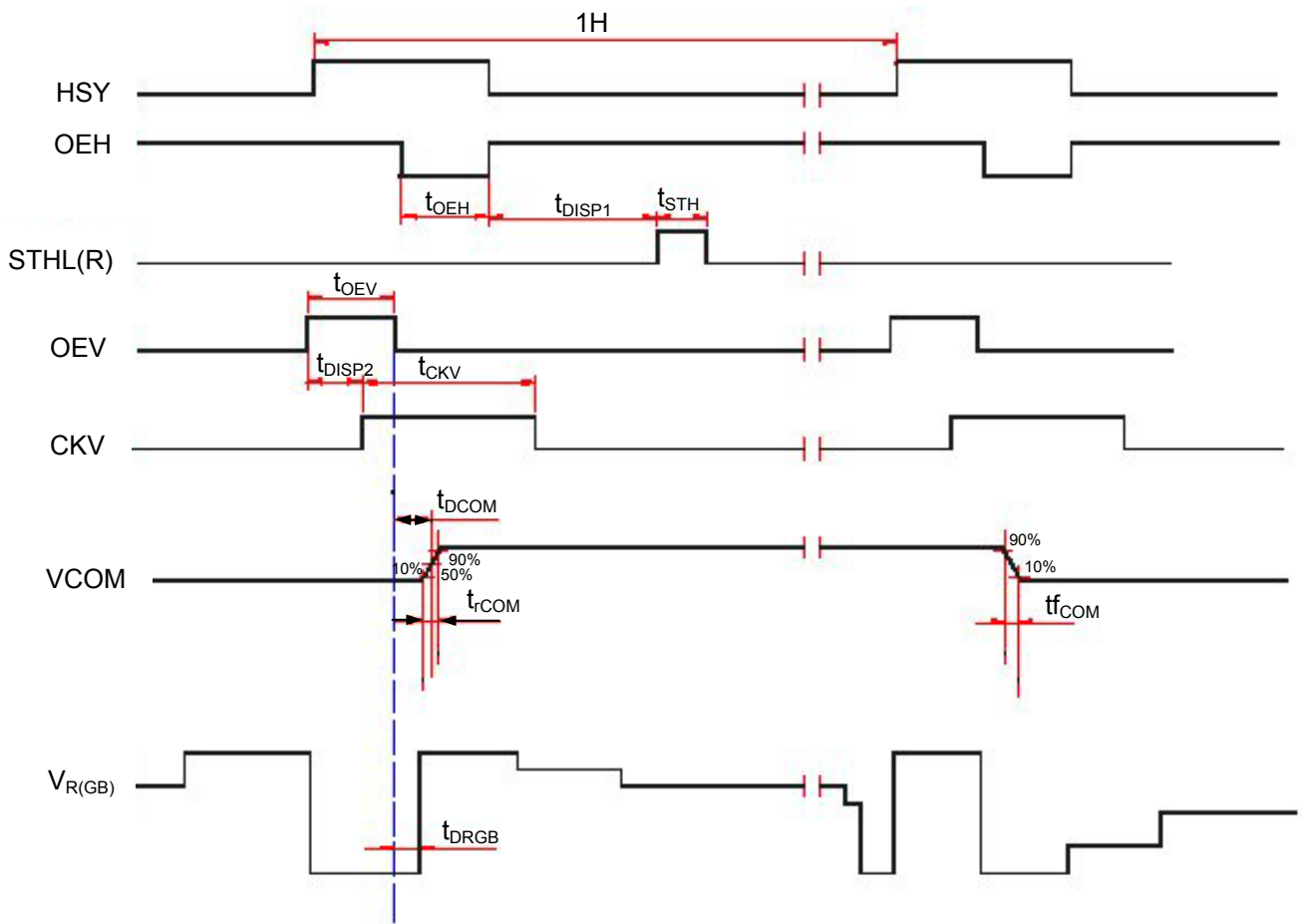

Fig.3-(a) Horizontal timing



Note: The falling edge of OEV should be synchronized with the falling edge of OEH

Fig.3-(b) Detail horizontal timing

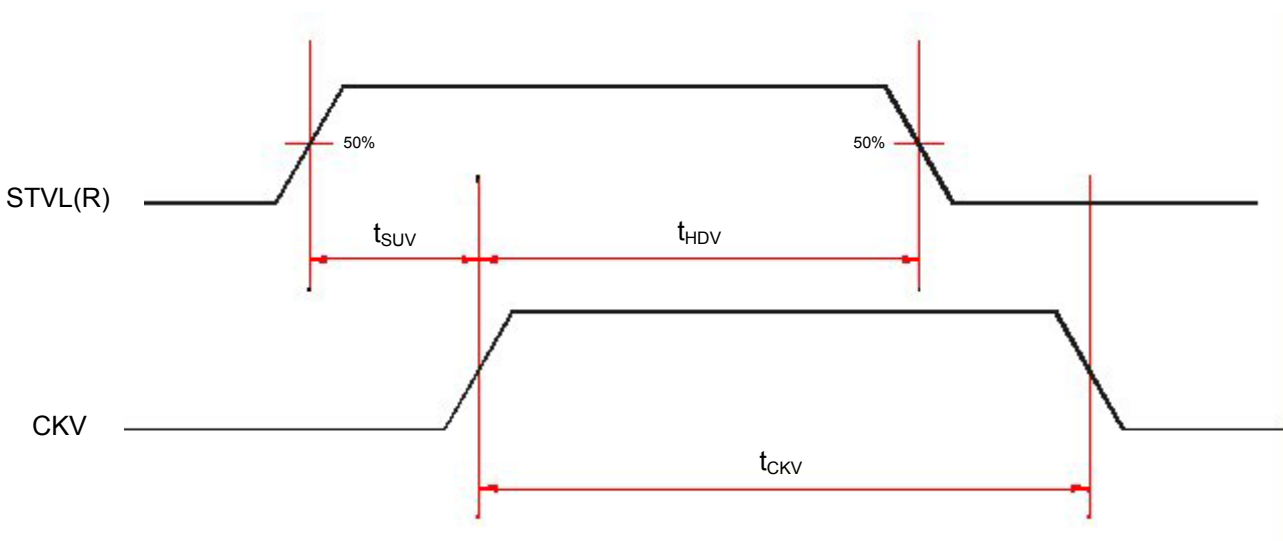

Fig.4 Vertical shift clock timing

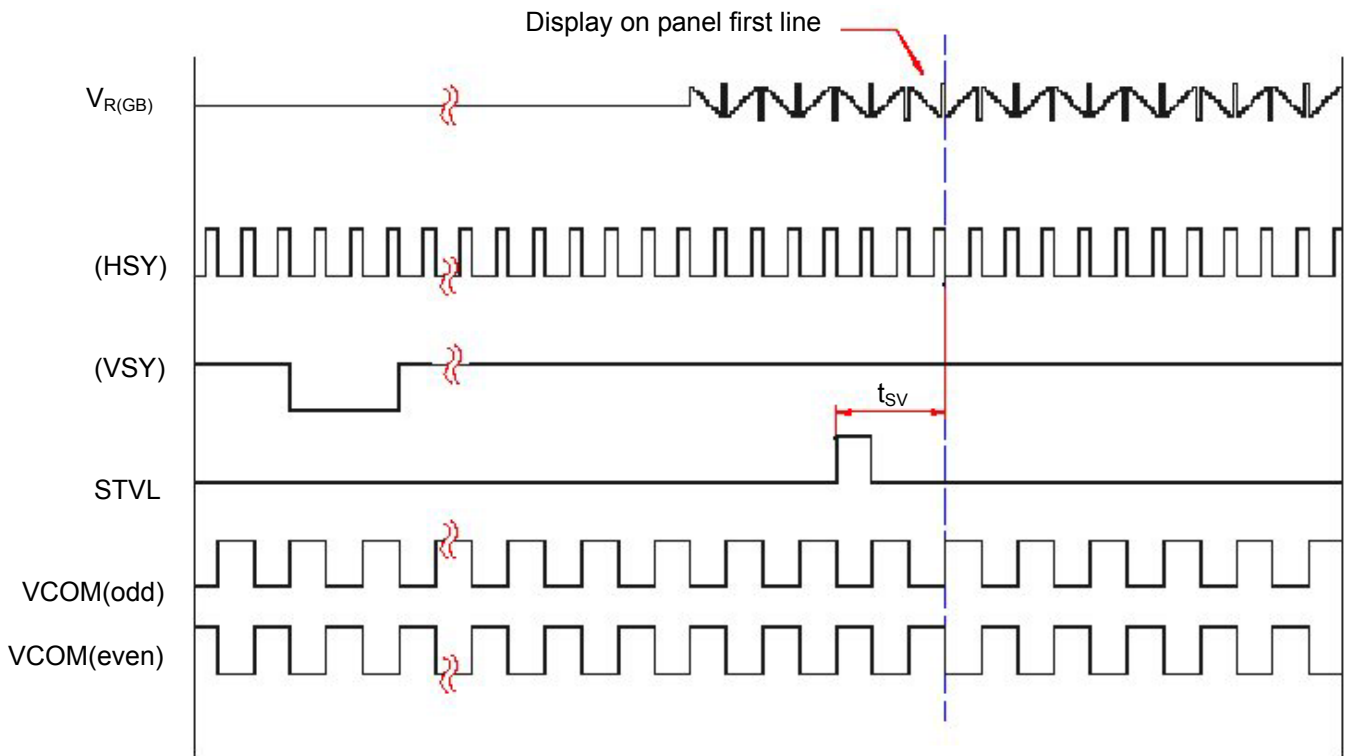

Fig.5-(a) Vertical timing (from up to down)

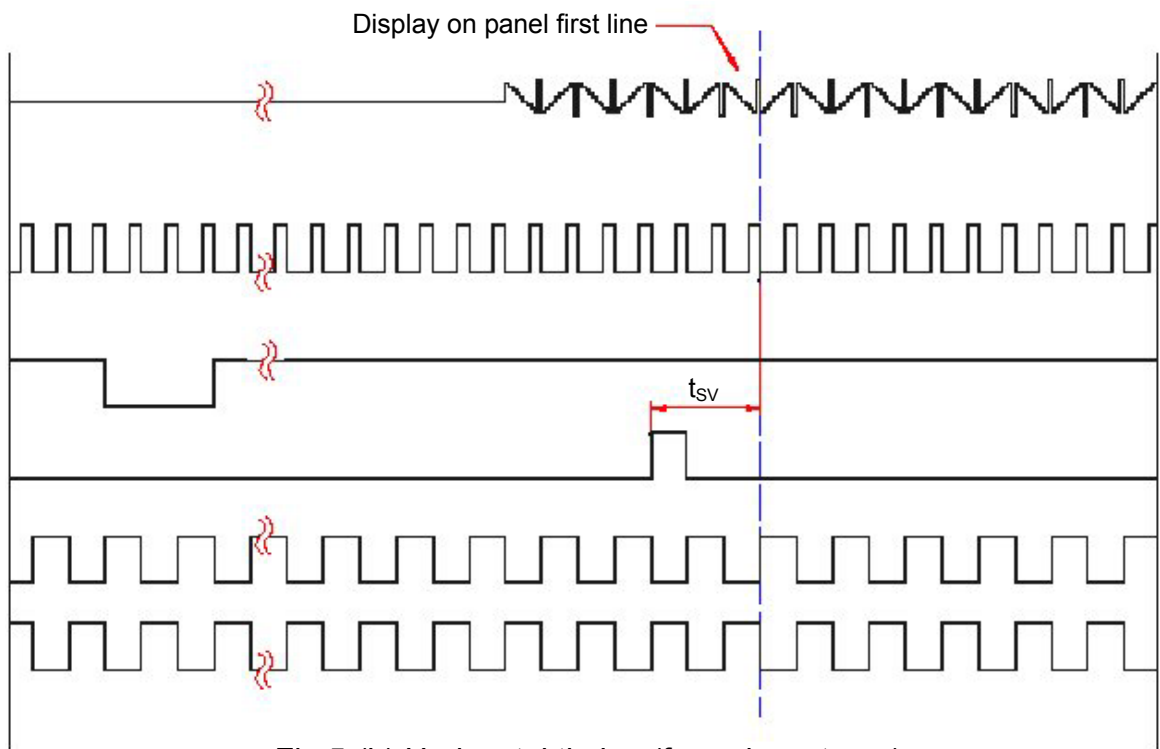
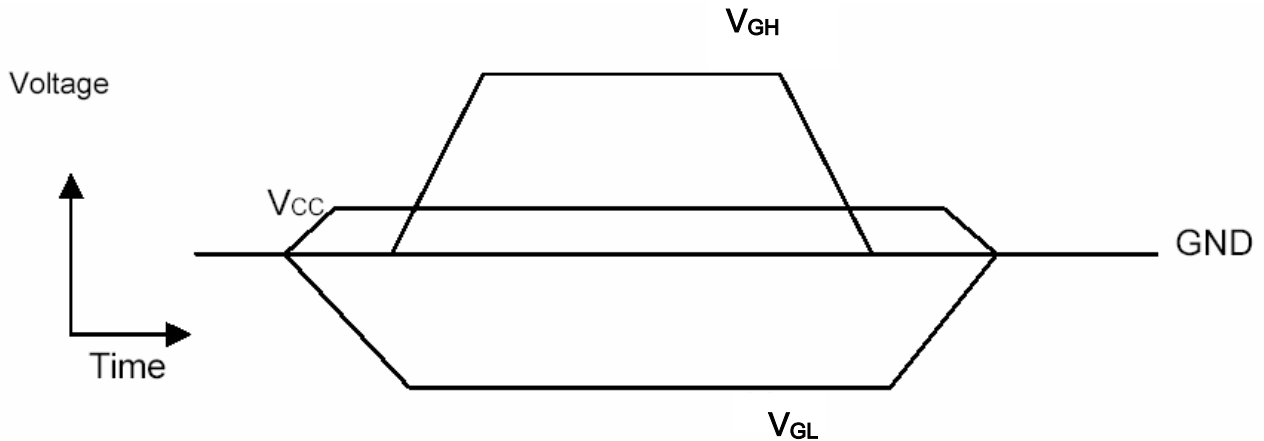

Fig.5-(b) Horizontal timing (from down to up)

### (5) Power sequence

This module adopts high voltage driver IC, so it may be damaged by a large current flow if a wrong power on/off sequence is used! The recommend power sequence is to connect  $V_{CC}$  first, then connect power to driver gate power,  $V_{GL}$  and  $V_{GH}$ . When shutting off the power, shut off the driver gate power,  $V_{GL}$  and  $V_{GH}$ , then shut off the logic power,  $V_{CC}$ , or shut off the power simultaneously!



### 3. Optical specifications

The following items are measured under stable conditions. The optical characteristics should be measured in dark room or equivalent state with the methods shown in Note 1.

Ta=25±2°C, I<sub>L</sub>=6mA

Item		Symbol	Condition	Min	Typ	Max	Unit	Remark
Response time		T <sub>R</sub>	Θ=0	-	10	50	ms	Note2
		T <sub>F</sub>		-	20	60	ms	
Contrast ratio		CR	At optimized viewing angle	200	300			Note3
Brightness		Y <sub>L</sub>	Θ=0	250	300		Cd/m <sup>2</sup>	Note4
Color Chromaticity	White	W <sub>x</sub>	Θ=0	0.26	0.31	0.36		Note4
		W <sub>y</sub>		0.28	0.33	0.38		
Viewing Angle	Hor.	Θ <sub>R</sub>	CR≥10		40		Degree	Note5
		Θ <sub>L</sub>			40			
	Ver.	Φ <sub>H</sub>			15			
		Φ <sub>L</sub>			35			

Note:

1. Test equipment setup

After stabilizing and leaving the panel alone at a given temperature for 30 minutes, the measurement should be executed. Measurement should be executed in a stable, windless, and dark room. Optical specifications are measured by Topcon BM-5A with a viewing angle of 1° at a distance of 50cm and normal direction.

2. Definition of response time: T<sub>R</sub> and T<sub>F</sub>

The figure below is the output signal of the photo detector.

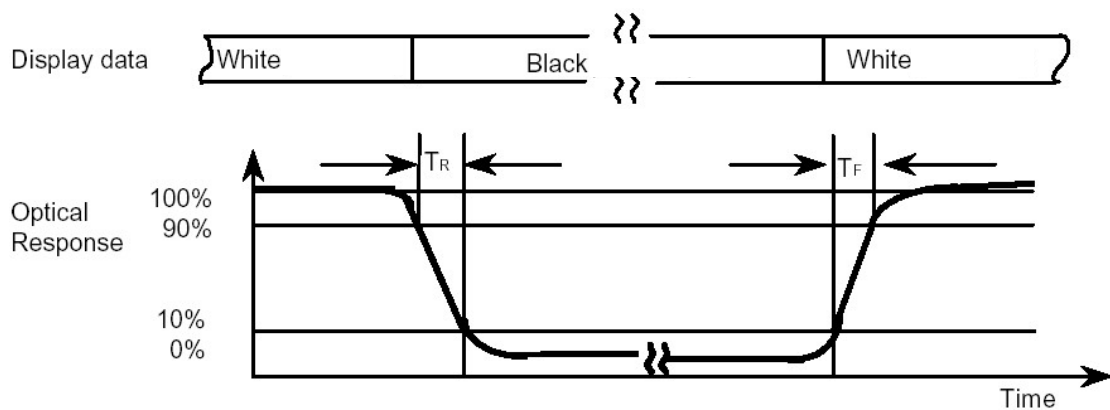

## 3. Definition of contrast ratio:

$$\text{Contrast ratio (CR)} = \frac{\text{Brightness measured when LCD is at "white" state}}{\text{Brightness measured when LCD is at "black" state}}$$

White  $V_i = V_{i50\%} \pm 1.5 \text{ V}$

Black  $V_i = V_{i50\%} \mp 2.0 \text{ V}$

“ $\pm$ ” means that the analog input signal swings in phase with  $V_{\text{COM}}$  signal.

“ $\mp$ ” means that the analog input signal swings out of phase with  $V_{\text{COM}}$  signal.

$V_{i50\%}$ : The analog input voltage when transmission is 50%

The 100% transmission is defined as the transmission of LCD panel when all the input terminals of module are electrically opened.

4. Measured at the center area of the panel when all the input terminal of LCD panel are electrically opened.

## 5. Definition of viewing angle:

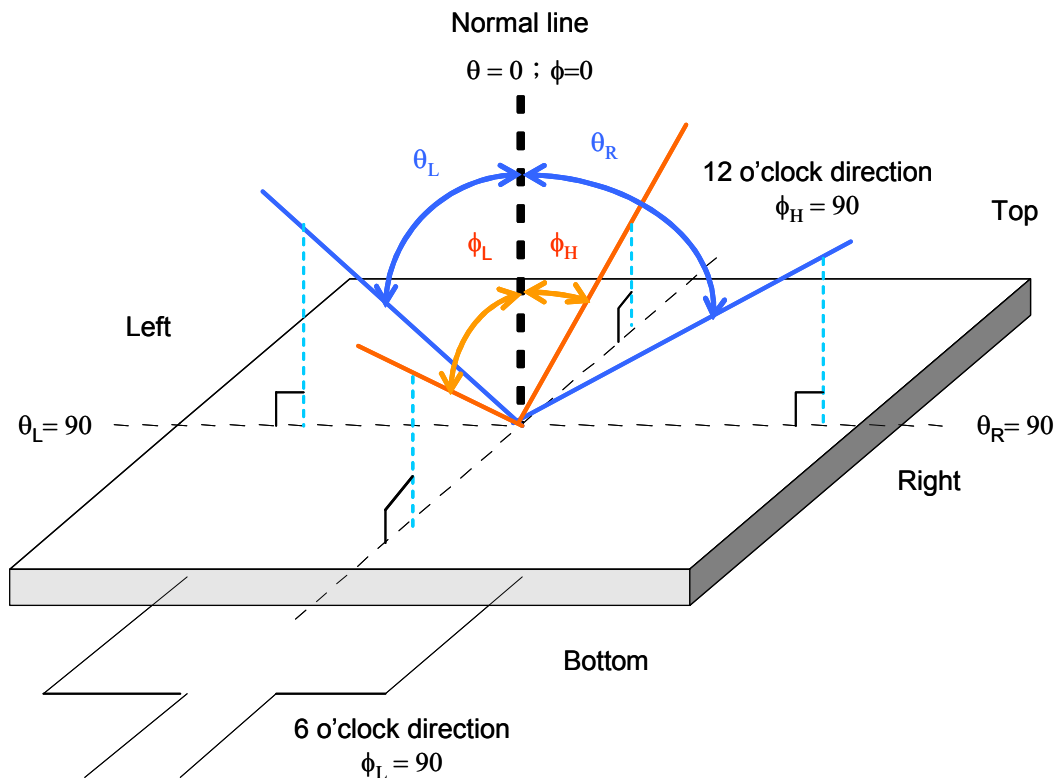

#### 4. Reliability test items

(1). Reliability levels in mass production are as below:

Test Items	Test Conditions
High temperature storage	+70°C±3°C, Dry(30%RH max.) For 240 hours
Low temperature storage	-20°C±3°C for 240 hours
High temperature operation	+60°C±3°C, Dry(30%RH max.) for 240 hours
Low temperature operation	-10°C±3°C for 240 hours
Operation at high temperature and humidity	+40°C±3°C,90%±3%RH max. for 240 hours
Thermal shock	-20degree/0.5h ~ +70 degree/0.5h for a total 20 cycles
Mechanical shock	Drop onto the tilted floor from 60cm heights, 1 corner, 3 edges, 6 faces. Apply shipping package to this test
Vibration test	Sweep at 10Hz to 55Hz to 10Hz, amplitude 0.75mm for 20cycles each in X,Y and Z directions. Apply shipping package to this test.

Note1: High temp storage & High temp/High humidity Op the polarizer is out of subject

Note 2: the test sample has recovery time 2 hours at room temp before function check

#### 5. Handling precautions

##### 1 Safety

The liquid crystal in the LCD is poisonous. **DO NOT** put it in your mouth. If the liquid crystal touches your skin or clothes, wash it off immediately using soap and water.

##### 2 Handling

- 1) The LCD panel is plate glass. **DO NOT** subject the panel to mechanical shock or to excessive force on its surface.
- 2) The polarizer attached to the display is very easy to damage, handle it with careful attention.
- 3) To avoid contamination on the display surface, **DO NOT** touch the display surface with bare hands.
- 4) Provide a space so that the LCD panel does not come into contact with other components.
- 5) To protect the LCD panel from external pressure, put covering glass (acrylic board or similar board) keeping appropriate gap between them.
- 6) Transparent electrodes may be disconnected if you use the LCD panel under environmental conditions where dew condensation occurs.
- 7) Property of semiconductor devices may be affected when they are exposed to light, possibly resulting in malfunctioning of the ICs.
- 8)To prevent such malfunctioning of the ICs, your design and mounting layout done are so that the IC is not exposed to light in actual use.



### 3 Static electricity

- 1) Ground soldering iron tips, tools and testers when you operate.
- 2) Ground your body when handling the products.
- 3) **DO NOT** apply voltage to the input terminal without applying power supply.
- 4) **DO NOT** apply voltage which exceeds the absolute maximum rating.
- 5) Store the products in an anti-electrostatic container.

### 4 Storage

- 1) Store the products in a dark place at  $+25^{\circ}\text{C}\pm 10^{\circ}\text{C}$ , low humidity (65%RH or less).
- 2) **DO NOT** store the products in an atmosphere containing organic solvents or corrosive gases.

### 5 Cleaning

- 1) **DO NOT** wipe the polarizer with dry cloth, as it might cause scratch.
- 2) Wipe the polarizer with a soft cloth soaked with petroleum IPA, other chemical might damage.

## 6. Mechanical dimensions

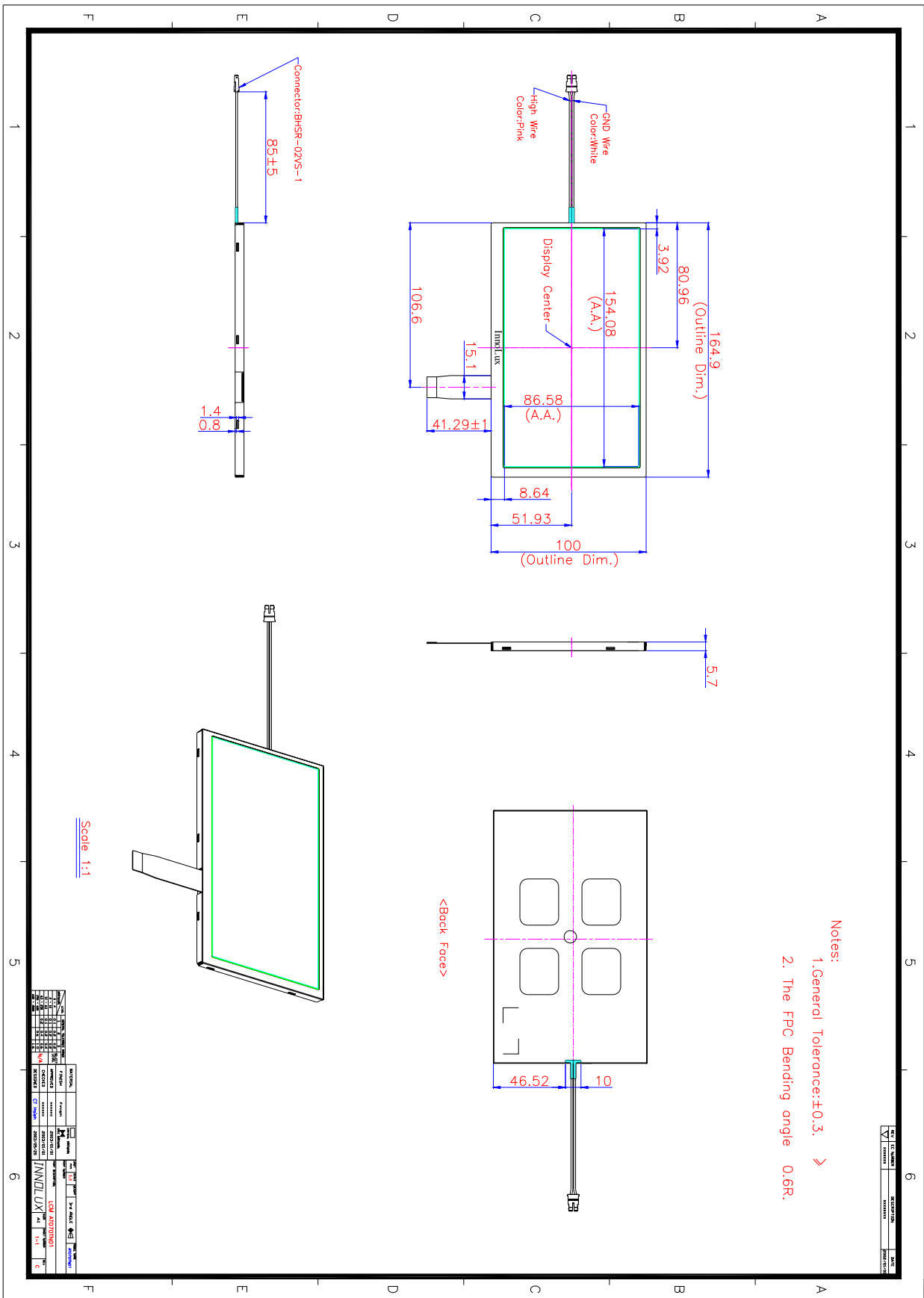

## 7. Packing specifications

## (1). Packaging material table

Per carton

No	Item	Model (Material)	Dimensions (mm)	Unit Weight (Kg)	Quantity	Remark
1	LCM module	AT070TN01	164.9*100*5.7	0.160	30	
2	EPP tray	EPP	516*384*6.5	0.07	7	Anti-static
3	Carton	Carton	530*355*255	1.06	1	
4	Total weight	6.5 Kg $\pm$ 5%				

## (2). Packaging quantity

(1) LCM quantity per tray: no. of the row	5 x no. the column	6 = 30
(2) Total LCM quantity in Carton: no. of EPP trays	30 x quantity per tray	7 = 30