

Features

- Low input voltage: 2.5V to 7V
- 2-Channels PWM Control:
 - 1 Boost Controller(CH1)
 - 1 Inverting Controller (CH2)
- Adjustable Soft start time and maximum duty cycle
- Built-in timer latch for short circuit protection:
 Delay time= $2^{16}/(\text{Switching frequency})$
- Built-in under-voltage lockout, thermal shutdown.
- High operating frequency: 100kHz to 1MHz

General Description

The AT1731 is a PWM DC/DC converter control IC with 2 channel outputs that can directly drive power MOSFET. This IC is suitable for very small DC/DC converters because of their small and thin package(1.1 mm max.), and high operation frequency (up to 1.0 MHz).

Applications

- LCD Displays Bias
- Power Supply for general equipment

Block Diagram

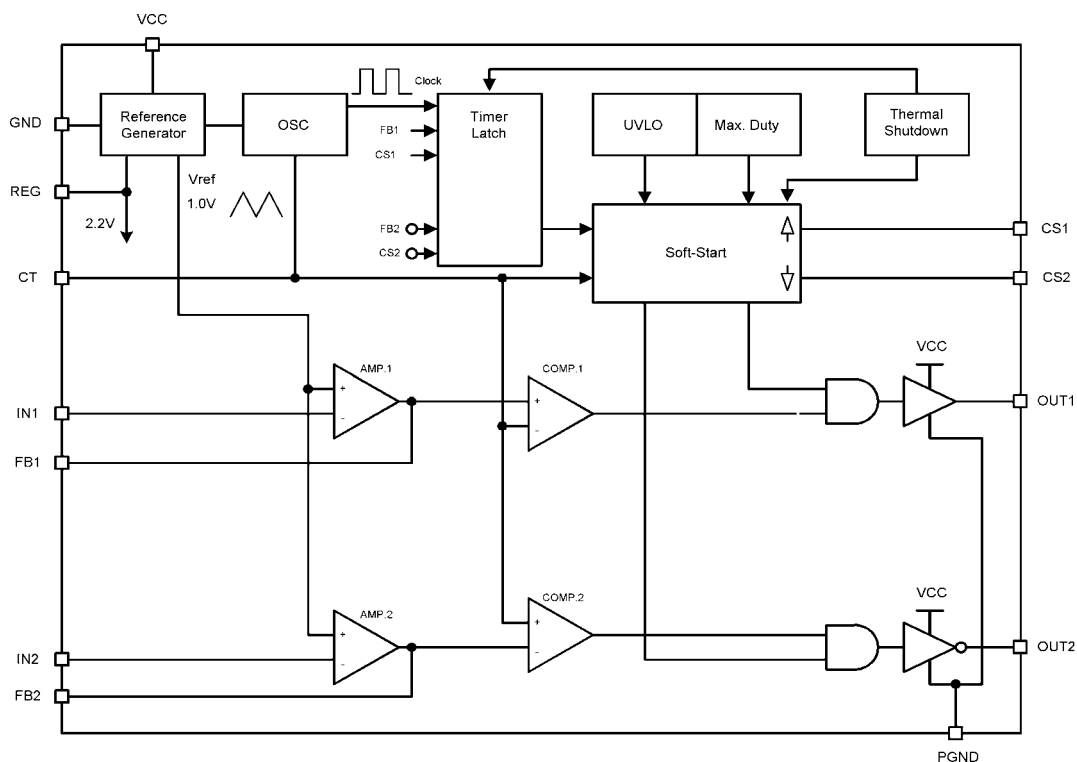

Pin Configuration

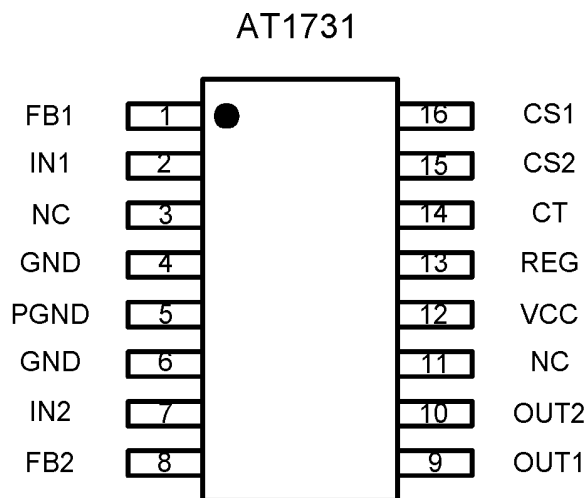

Ordering Information

Part number	Package	Marking
AT1731	TSSOP16	AT1731P
		-

Pin Description

Symbol	Pin No.	Descript	Symbol	Pin No.	Descript
FB1	1	CH1 error amplifier output	OUT1	9	CH1 output for Nch-MOSFET
IN1	2	CH1 inverting input to error amplifier	OUT2	10	CH2 output for Pch-MOSFET
NC	3	Don't connect	NC	11	Don't connect
GND	4	Control blocks ground	VCC	12	Power Supply
PGND	5	Power blocks ground	REG	13	Regulated voltage output
GND	6	Control blocks ground	CT	14	Oscillator timing capacitor
IN2	7	CH2 inverting input to error amplifier	CS2	15	Soft-start for CH2
FB2	8	CH2 error amplifier output	CS1	16	Soft-star for CH1

Absolute Maximum Ratings

Parameter	Condition	Rated Value		Unit
		Min.	Max.	
Power Supply Voltage	—	-	+8	V
Source Average Current of OUT1 OUT2	—	-	-50	mA
Sink Average Current of OUT1 OUT2	—	-	50	mA
Input Voltage to Error Amplifier	—	-	6.5	V
Continuous power dissipation	TSSOP16 (T _a =+25°C)	-	500	mW
Operating temperature	—	-30	+85	°C
Junction temperature	—	-	+125	°C
Storage temperature	—	-40	+150	°C
Lead temperature	—	-	+300	°C

Stresses beyond those listed under “Absolute Maximum Ratings” may cause permanent damage to the device. These are stress ratings only, and functional operation of the device at these or any other conditions beyond those indicated in the operational sections of the specifications is not implied. Exposure to absolute maximum rating conditions for extended periods may affect device reliability.

Recommended Operating Conditions

(T_a=+25°C)

Parameter	Symbol	Values			Unit
		Min.	Typ.	Max.	
Power supply voltage	V _{CC}	2.5	--	7	V
Oscillation frequency	f _{osc}	100	500	1000	KHz
Operating temperature	T _{op}	-30	+25	+85	°C

Electrical Characteristics

(VCC = 3V, T_a = +25°C, unless otherwise noted.)

Parameter	Symbol	Condition	Values			Unit	
			Min.	Typ.	Max.		
Entire device	Input Supply Range	V _{CC}	2.5	--	7.0	V	
	VCC Undervoltage Lockout	UVLO	1.95	2.05	2.15	V	
	Reference Voltage	V _{REF}	0.98	1.00	1.02	V	
	Reference Voltage line-regulation	V _{REF-Line}	VCC=2.5V to 7.0V		1	5	mV
	Reference Variation with Temperature		T _a = -30°C to +85°C		0.5	1.5	%
	Operating Current	I _{CC}	Duty=50%, f _{OSC} =500KHz		3.0	3.8	mA
Error amplifier	Input Offset Voltage	V _{IO}			10	mV	
	Source Current (CH1,2)	I _{OH}	V _{FB} = V _{REG} - 0.5V	-160	-120	-80	μA
	Sink Current(CH1,2)	I _{OL}	V _{FB} = 0.5V	2.0	2.5	3.0	mA
	Source current Variation with temperature		T _a = -30°C to +85°C			20	%
	Sink current Variation with temperature		T _a = -30°C to +85°C			20	%
	Unity Gain Bandwidth	f _T			2.0		MHz
	Common Mode Input Voltage Range	V _{COM}		0.2		1.5	V
	DC Open Loop Gain	A _V			80		dB
Sawtooth wave Oscillator (OSC)	Frequency	f _{osc}	C _T = 150pF	480	550	620	kHz
	High Level Voltage		C _T = 150pF		1.0		V
	Low Level Voltage		C _T = 150pF		0.5		V
	Variation with Power Supply		V _{CC} = 2.5V to 7V			2	%
	Variation with Temperature		T _a = -30°C to +85°C			7	%
Regulated Voltage for internal Control Block	Regulated Voltage	V _{REG}	C _O = 0.1 μF	2.16	2.20	2.24	V
	Variation with Power Supply		V _{CC} = 2.5V to 7V			1.5	%
	Variation with Temperature		T _a = -30°C to +85°C			1.5	%
	Source Current	I _{REG}		-40	-	-15	mA
Soft-Start and Duty Section	Charge Current of CS1(Source)	I _{CS1,2}			-1.0	mA	

	Charge Current of CS2(Sink)	I_{CS3}			1.0		mA
	Max. Duty of CH1		$f_{OSC}=500\text{KHz}$	80	87	90	%
	Max. Duty of CH2		$f_{OSC}=500\text{KHz}$	80	86	90	%
	Invalid TL threshold voltage of CS1				0.3		V
	Invalid TL threshold voltage of CS2				1.32.		V
Timer Latch Section (TL)	Threshold Voltage of FB1	V_{TLTH1}			1.32		V
	Threshold Voltage of FB2	V_{TLTH2}			0.3		V
	Start up count	Count			216		
	Start up time	T_{TL}		105	119	137	ms
Thermal ShUTDOWN Section	Threshold Temperature	T_{OH}			140		$^{\circ}\text{C}$
Output Section	Rise time of OUT1	t_{r1}	$C_o = 1000\text{pF}$ between OUT1-GND	20	25	35	ns
	Rise time of OUT3	T_{r2}	$C_o = 1000\text{pF}$ between VCC-OUT2	20	25	35	ns
	Fall time of OUT1	t_{f1}	$C_o = 1000\text{pF}$ between OUT1-GND	20	25	35	ns
	Fall time of OUT2	t_{f2}	$C_o = 1000\text{pF}$ between VCC-OUT2	20	25	35	ns
	High Level on Resistance of OUT1	R_{1AH}	$I_{OUT1}=-150\text{mA}$	2.5	4.0	5.5	Ω
	Low Level on Resistance of OUT1	R_{1AL}	$I_{OUT1}=150\text{mA}$	2.5	4.0	5.5	Ω
	High Level on Resistance of OUT2	R_{2AH}	$I_{OUT2}=-150\text{mA}$	2.5	4.0	5.5	Ω
	Low Level on Resistance of OUT2	R_{2AL}	$I_{OUT2}=150\text{mA}$	2.5	4.0	5.5	Ω

Typical Application Circuit

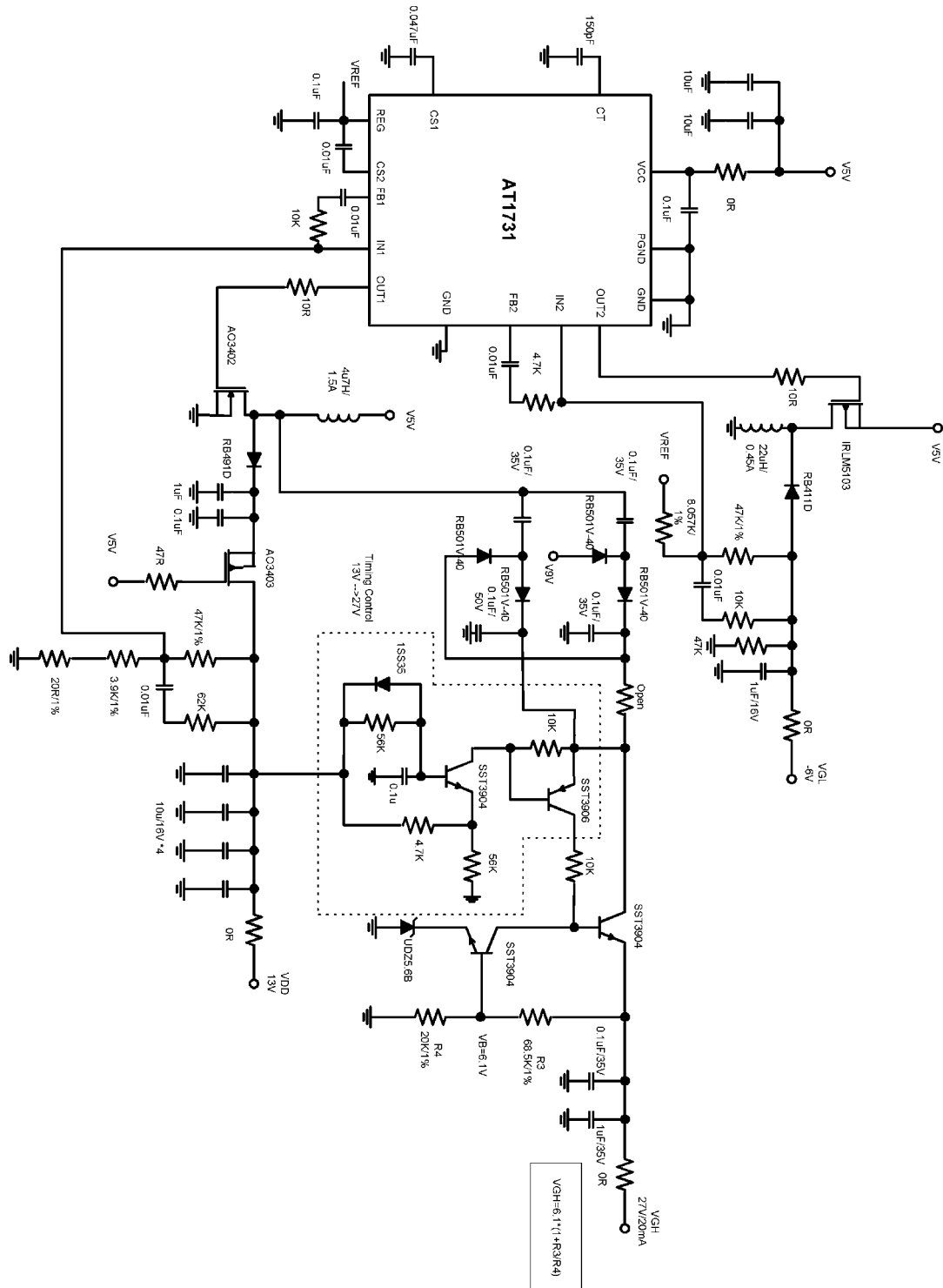

Package Outline 16-pin TSSOP

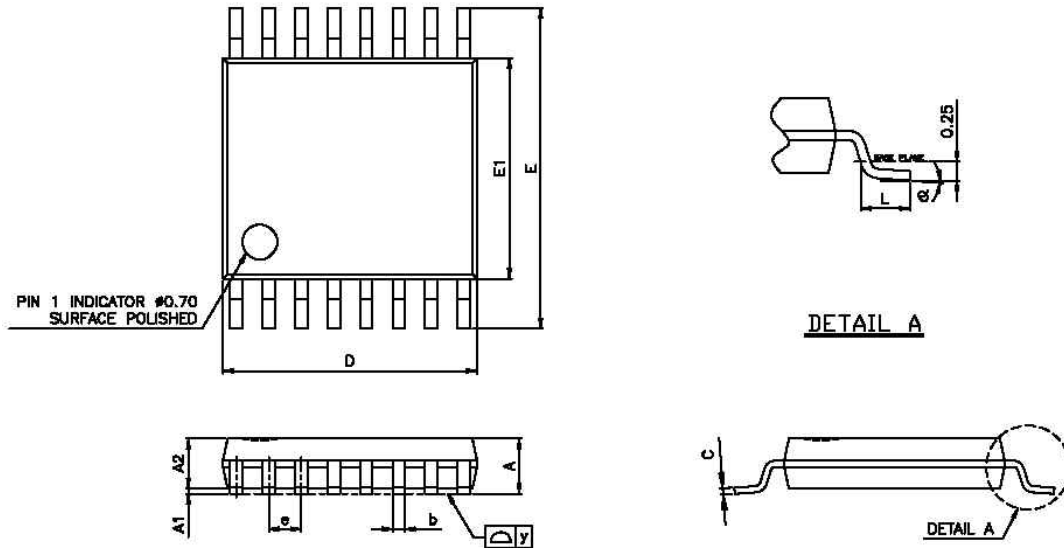

SYMBOL	MILLIMETERS			INCHES		
	MIN	TYP	MAX	MIN	TYP	MAX
A	1.05	1.10	1.20	0.041	0.043	0.047
A1	0.05	0.10	0.15	0.002	0.004	0.006
A2	-	1.00	1.05	-	0.039	0.041
b	0.20	0.25	0.28	0.008	0.010	0.011
C	-	0.127	-	-	0.005	-
D	4.90	5.075	5.10	0.193	0.1998	0.200
E	6.20	6.40	6.60	0.244	0.252	0.260
E1	4.30	4.40	4.50	0.170	0.173	0.177
L	0.50	0.60	0.70	0.020	0.024	0.028
e	-	0.65	-	-	0.026	-
y	-	-	0.076	-	-	0.003
θ	0°		8°	0°		8°

Reflow Condition (IR/Convection or VPR Reflow)

Reference JEDEC Standard J-STD-020A

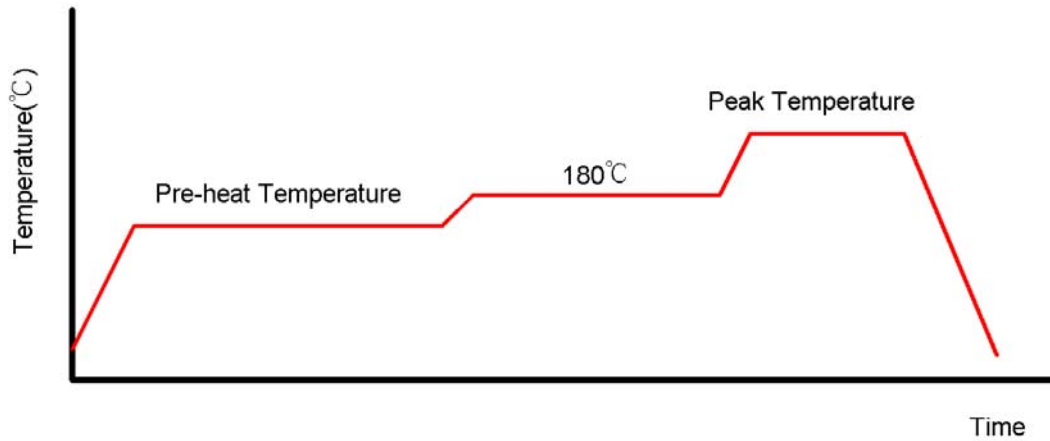

Classification Reflow Profiles

	Convection or IR/Convection	VPR
Average Heating Rate(180°C to peak)	5°C/second max.	10°C/second max.
Preheat Temperature(125±20°C)	120 seconds max.	
Temperature maintained above 180°C	10~150 seconds	
Time within 5°C of actual Peak Temperature	10~20 seconds	60 seconds
Peak Temperature Range(Note 1)	219~225°C or 235~240°C	219~225°C or 235~240°C
Cooling Rate	6°C /second max.	10°C/second max.
Time 25°C to Peak Temperature	6 minutes max.	

*1 The maximum peak temperatures for IR and VP reflow are depending on package dimensions.

Package Reflow Conditions

Pkg. Thickness ≥2.5mm and all bags	Pkg. Thickness <2.5mm and Pkg. Volume ≥350 mm ³	Pkg. Thickness <2.5mm and Pkg. Volume <350 mm ³
Convection 219~225°C		Convection 235~240°C
VPR 219~225°C		VPR 235~240°C
IR/Convection 219~225°C		IR/Convection 235~240°C