

AT2575

2A Step Down Voltage Switching Regulators



Immense Advance Tech.

FEATURES

- Standard SOP-8 Package
- 3.5V, 5V, and Adjustable Output Versions
- Adjustable Version Output Voltage Range 1.23V to 37V
- V_{OUT} Accuracy is to $\pm 3\%$ Under Specified Input Voltage the Output Load Conditions
- Input Voltage Range Up to 40V
- Requires Only 4 External Components with High Efficiency
- TTL Shutdown Capability, Low Power Standby Mode
- Built-in Thermal Shutdown, Current Limit Protection
- Uses Standard Inductors
- 52 KHz Fixed Frequency Internal Oscillator

APPLICATION

- Pre-Regulator for Linear Regulators
- High-Efficiency Step-Down Buck Regulator
- On-Card/ Board Switching Regulators
- Positive to Negative Converter (Buck)

DESCRIPTION

The AT2575 series of regulators are monolithic integrated circuits that provide all the active functions for a step-down (buck) switching regulator, capable of driving a 2A load with excellent line and load regulation. These devices are available in fixed output voltages of 3.3V, 5V and an adjustable output version.

Requiring a minimum number of external components, these regulators are simple to use and include internal frequency compensation, and a fixed-frequency oscillator.

A standard series of inductors are available from several different manufacturers optimized for use with the AT2575 series. This feature greatly simplifies the design of switch-mode power supplies.

The output voltage is guaranteed to $\pm 3\%$ tolerance under specified input voltage and output load conditions. The oscillator frequency is guaranteed to $\pm 10\%$. External shutdown is included, featuring typically 50 μ A standby current. Self protection features include a two stage frequency reducing current limit for the output switch and an over temperature shutdown for complete protection under fault conditions.

ORDER INFORMATION

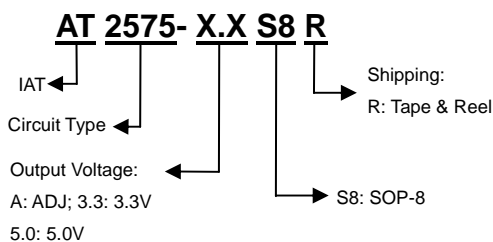

PIN CONFIGURATIONS (TOP VIEW)

SOP-8

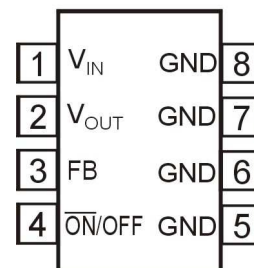

AT2575

2A Step Down Voltage Switching Regulators



Immense Advance Tech.

PIN DESCRIPTIONS

Pin Name	Pin Description
V _{IN}	Input supply voltage.
V _{OUT}	Switching output.
FB	Output voltage feedback.
ON/OFF	ON/OFF Shutdown. Active is "Low" or floating.
GND	Ground.

TYPICAL APPLICATION CIRCUITS

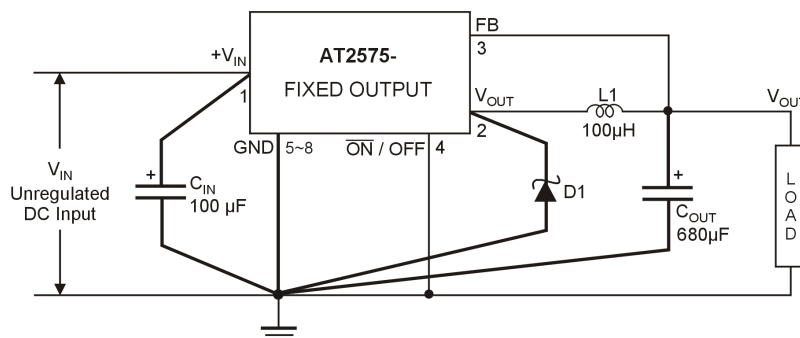

Figure 1. Typical application circuit for AT2575-5.0S8R

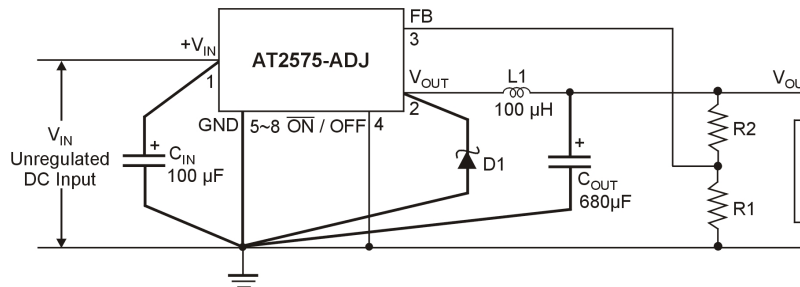
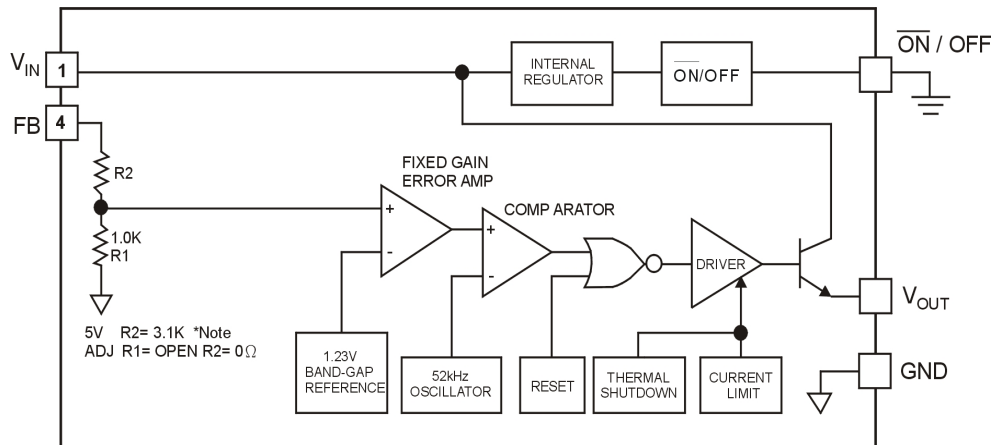

Figure 2. Typical application circuit for AT2575-AS8R

BLOCK DIAGRAM



*Note: The R1 and R2 value are guaranteed by design.

Figure 3. Functional Block Diagram of AT2575

AT2575

2A Step Down Voltage Switching Regulators



Immense Advance Tech.

ABSOLUTE MAXIMUM RATINGS (Note 1)

Parameter	Symbol	Max Value	Unit
Maximum supply Voltage	V_{CC}	45	V
ON/OFF Pin Input Voltage / Feed Back Pin Voltage	$V_{\overline{ON/OFF}/V_{FB}}$	$-0.3 \leq V \leq +V_{IN}$	V
V_{OUT} Ground (Steady State)	V_{OUT}	$-0.3 \leq V \leq +V_{IN}$	V
Maximum Junction Temperature	T_J	150	°C
Storage Temperature Range	T_{STG}	-65 to +150	V
Lead Temperature (Soldering, 5sec)	T_{LEAD}	260	°C
Power Dissipation P_D @ $T_A=25^\circ\text{C}$ (Note 2)	SOP-8 P_D	625	mW
Thermal Resistance Junction to Ambient	SOP-8 Θ_{JA}	63	°C/W
ESD Rating (Human Body Model) (Note 3)	V_{ESD}	2	kV

RECOMMENDED OPERATING CONDITIONS (Note 4)

Parameter	Symbol	Operation Conditions	Unit
Supply Voltage	V_{IN}	40	V
Operating Junction Temperature Range	T_J	-40 to +125	°C
Operating Ambient Temperature Range	T_A	-40 to +85	°C

Note 1: Stresses listed as the above "Absolute Maximum Ratings" may cause permanent damage to the device. These are for stress ratings. Functional operation of the device at these or any other conditions beyond those indicated in the operational sections of the specifications is not implied. Exposure to absolute maximum rating conditions for extended periods may remain possibility to affect device reliability.

Note 2: Thermal Resistance is specified with the component mounted on a low effective thermal conductivity test board in free air at $T_A=25^\circ\text{C}$.

Note 3: Devices are ESD sensitive. Handling precaution recommended.

Note 4: The device is not guaranteed to function outside its operating conditions.

AT2575

2A Step Down Voltage Switching Regulators



Immense Advance Tech.

ELECTRICAL CHARACTERISTICS

AT2575-ADJ

Specifications with standard type face are for $T_J=25^\circ\text{C}$, and those with **boldface type** apply over **Full Operating Temperature Range**, Test Circuit Figure 5.

Parameter	Symbol	Condition	Min	Typ (Note 5)	Max	Unit
Feedback Voltage	V_{FB}	$V_{IN}=12\text{V}, I_{LOAD}=0.5\text{A}, V_{OUT}=5\text{V}$	1.1931	1.23	1.2669	V
		$8\text{V} \leq V_{IN} \leq 40\text{V}, 0.1\text{A} \leq I_{LOAD} \leq 2\text{A}, V_{OUT}=5\text{V}$	1.1808	1.23	1.2792	V
Efficiency	η	$V_{IN}=12\text{V}, I_{LOAD}=2.0\text{A}, V_{OUT}=5\text{V}$		77		%

AT2575-3.3V

Specifications with standard type face are for $T_J=25^\circ\text{C}$, and those with **boldface type** apply over **Full Operating Temperature Range**, Test Circuit Figure 4.

Parameter	Symbol	Condition	Min	Typ (Note 5)	Max	Unit
Output Voltage	V_{OUT}	$V_{IN}=12\text{V}, I_{LOAD}=0.5\text{A}$	3.201	3.3	3.399	V
		$6\text{V} \leq V_{IN} \leq 40\text{V}, 0.5\text{A} \leq I_{LOAD} \leq 2\text{A}$	3.168 3.135	3.3	3.432 3.465	V
Efficiency	η	$V_{IN}=12\text{V}, I_{LOAD}=2.0\text{A}$		75		%

AT2575-5.0V

Specifications with standard type face are for $T_J=25^\circ\text{C}$, and those with **boldface type** apply over **Full Operating Temperature Range**, Test Circuit Figure 5.

Parameter	Symbol	Condition	Min	Typ (Note 5)	Max	Unit
Output Voltage	V_{OUT}	$V_{IN}=12\text{V}, I_{LOAD}=0.5\text{A}$	4.850	5.0	5.150	V
		$8\text{V} \leq V_{IN} \leq 40\text{V}, 0.5\text{A} \leq I_{LOAD} \leq 2\text{A}$	4.800 4.750	5.0	5.200 5.250	V
Efficiency	η	$V_{IN}=12\text{V}, I_{LOAD}=2.0\text{A}$		77		%

All Output Voltage Versions

Specifications with standard type face are for $T_J=25^\circ\text{C}$, and those with **boldface type** apply over **Full Operating Temperature Range**, Unless otherwise specified, $V_{IN}=12\text{V}$ for the 3.3V, 5.0V and Adjustable version. $I_{LOAD}=200\text{mA}$

Parameter	Symbol	Condition	Min	Typ (Note 5)	Max	Unit
Feedback Bias Current	I_b	$V_{FB}=1.3\text{V}$ (Adjustable Version Only)		50	100 500	nA
Oscillator Frequency	F_{OSC}	(Note 6)	47	52	58	KHz
Saturation Voltage	V_{SAT}	$I_{OUT}=2\text{A}$ (Notes 7, 8)		1.4	1.8	V

AT2575

2A Step Down Voltage Switching Regulators



Immense Advance Tech.

					2.0	
--	--	--	--	--	-----	--

ELECTRICAL CHARACTERISTICS (CONTINUED)

All Output Voltage Versions

Specifications with standard type face are for $T_J=25^{\circ}\text{C}$, and those with **boldface type** apply over **Full Operating Temperature Range**.

Unless otherwise specified, $V_{IN}=12\text{V}$ for the 3.3V, 5.0V and Adjustable version. $I_{LOAD}=200\text{mA}$

Parameter	Symbol	Condition	Min	Typ (Note 5)	Max	Unit
Feedback Bias Current	I_b	$V_{FB}=1.3\text{V}$ (Adjustable Version Only)		50	100 500	nA
Oscillator Frequency	F_{OSC}	(Note 6)	47	52	58	KHz
Saturation Voltage	V_{SAT}	$I_{OUT}=2\text{A}$ (Notes 7, 8)		1.4	1.8 2.0	V
Max Duty Cycle(ON)	DC	(Note 8)	93	98		%
Current Limit	I_{CL}	Peak Current (Notes 7, 8)	4.2 3.5	5.8	6.9 7.5	A
Output Leakage Current	I_L	Output =0V (Notes 7, 9)		7.5	2	mA
		Output = -1V ($V_{IN}=36\text{V}$)(Notes 7, 9)			30	
Quiescent Current	I_Q	(Note 9)		5	10	mA
Standby Quiescent Current	I_{STBY}	$\overline{\text{ON/OFF}}$ Pin = 5V (OFF)		50	200	μA
$\overline{\text{ON/OFF}}$ Pin Logic Input Level	V_{IL}	Low (ON)		1.2	1.0 0.8	V
	V_{IH}	High (OFF)	2.2 2.4	1.4		
$\overline{\text{ON/OFF}}$ Pin Input Current	I_H	$V_{\overline{\text{ON/OFF}}}=2.5\text{V}$ (OFF)		12	30	μA
	I_L	$V_{\overline{\text{ON/OFF}}}=0.5\text{V}$ (ON)		0	10	

Note 5: Typical numbers are at 25°C and represent the most likely norm.

Note 6: External components such as the catch diode, inductor, input and output capacitors, and voltage programming resistors can affect switching regulator system performance.

Note 7: No diode, inductor or capacitor connected to output pin.

Note 8: Feedback pin removed from output and connected to 0V to force the output transistor switch ON.

Note 9: Feedback pin removed from output and connected to 12V for the 3.3V, 5V and the ADJ, Version, to force the output transistor switch OFF.

TYPICAL OPERATING CHARACTERISTICS

(1) Normalized Output Voltage

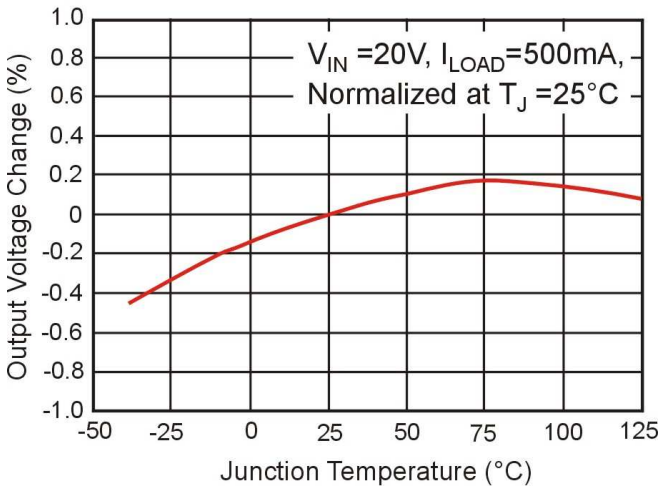

(2) Line Regulation

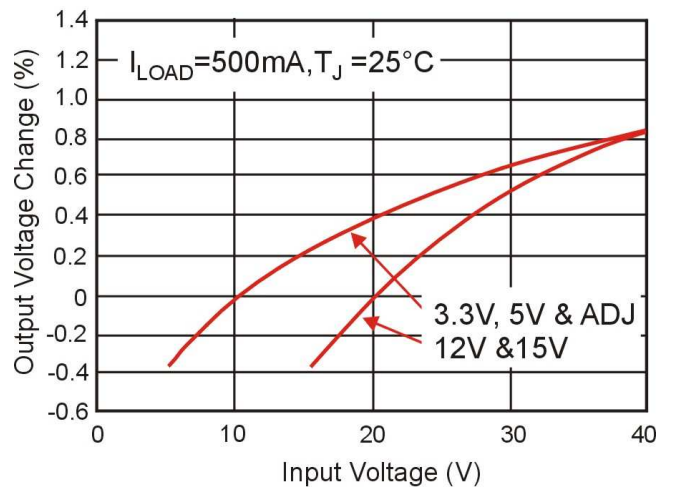

(3) Switch Saturation Voltage

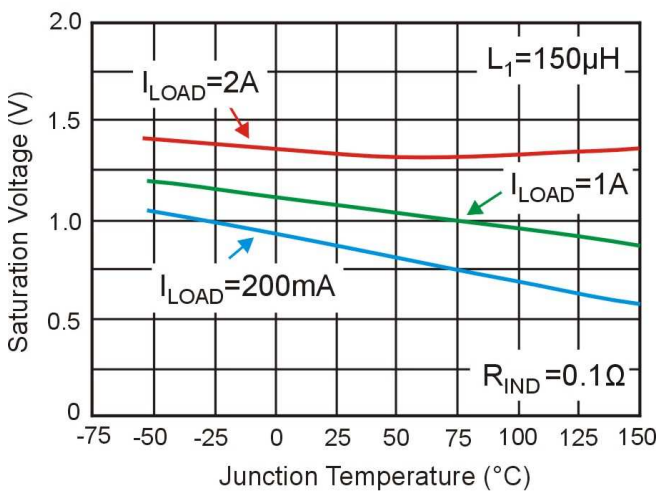

(4) Standby Quiescent Current

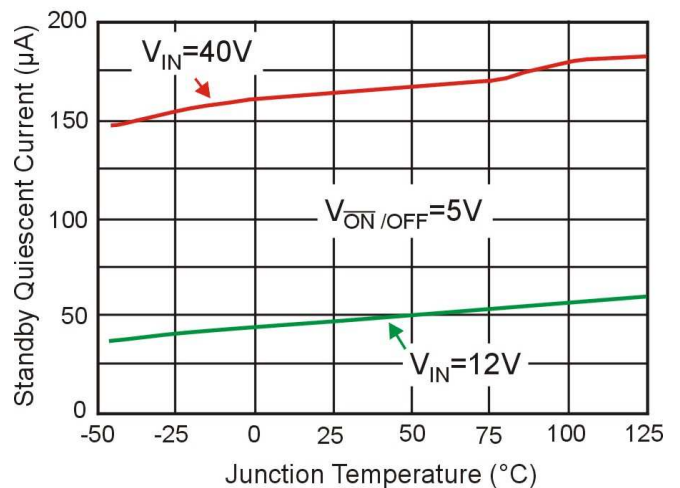

(5) Quiescent Current

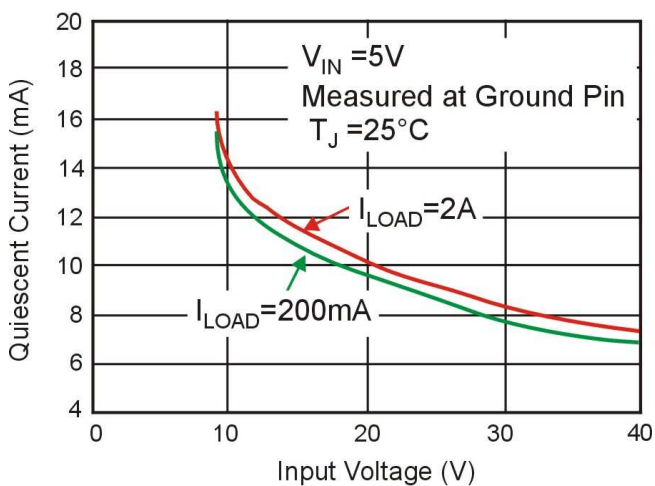

(6) Current Limit

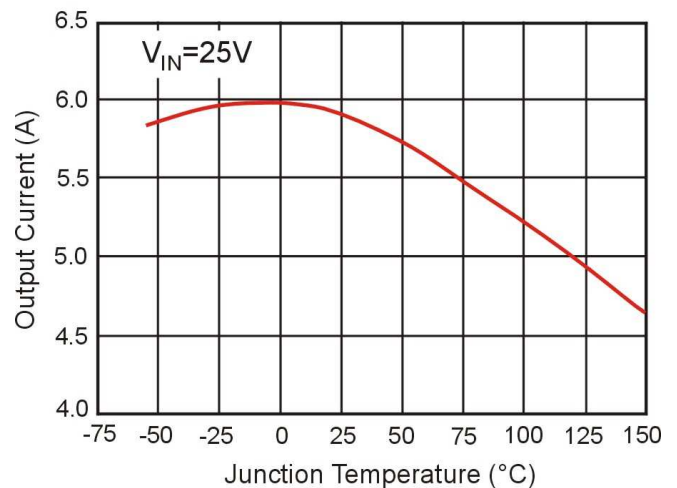

TYPICAL OPERATING CHARACTERISTICS (CONTINUED)

(7) Switch Saturation Voltage

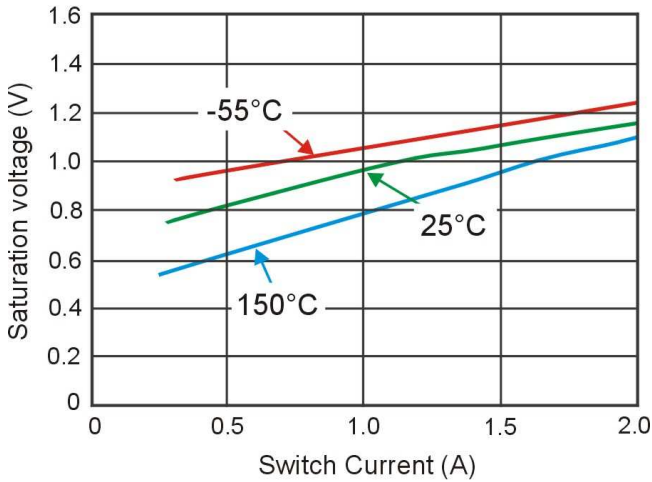

(8) Efficiency

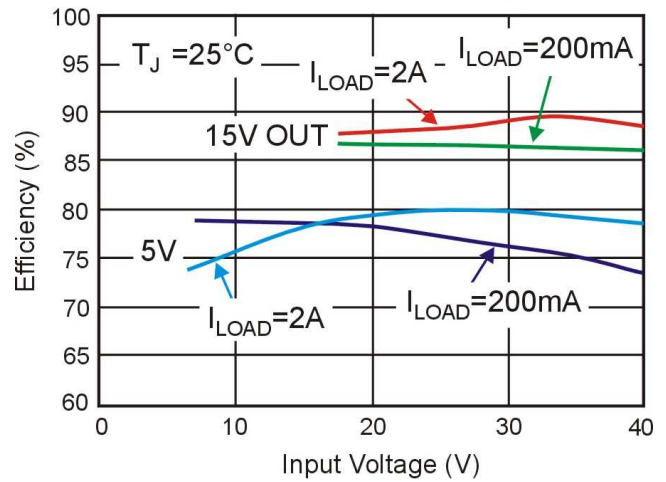

(9) Oscillator Frequency

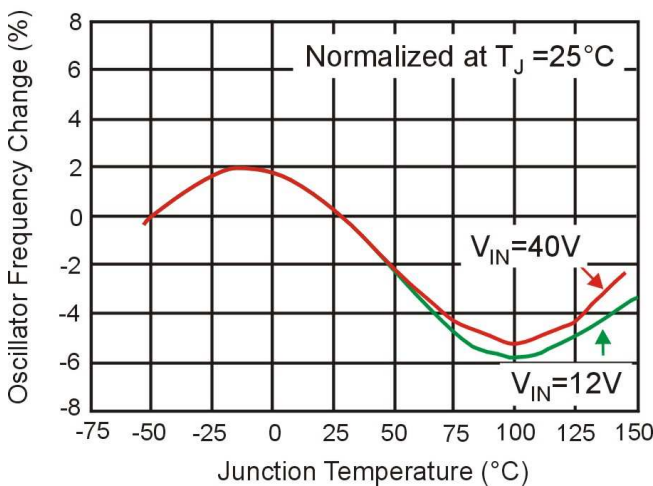

(10) Minimum Operating Voltage

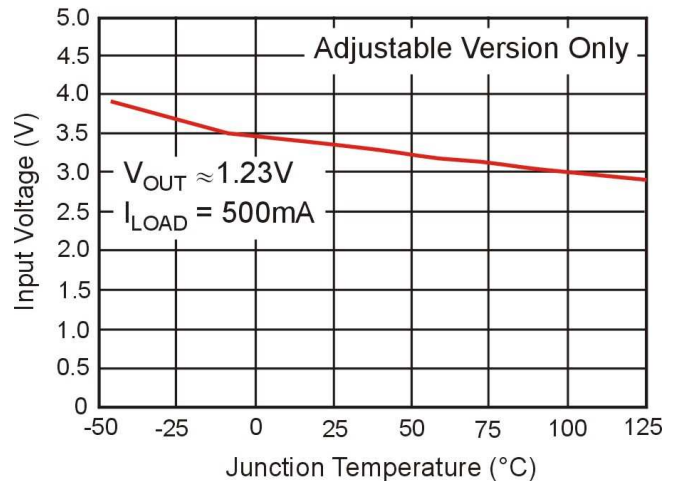

(11) Quiescent Current vs. Duty Cycle

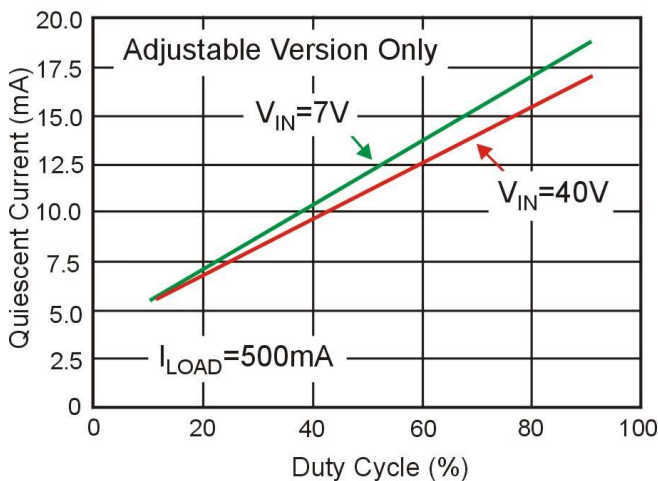

(12) Feedback Pin Current

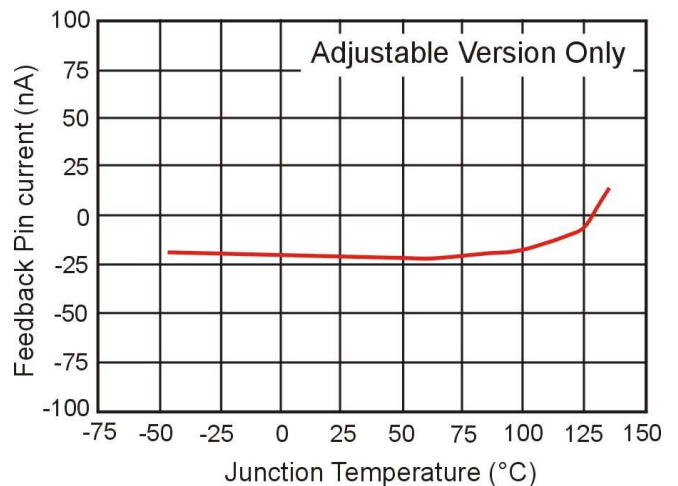

TEST CIRCUIT AND LAYOUT GUIDELINES

Careful layout is important with any switching regulator. Rapidly switching currents associated with wiring inductance generate voltage transients which can cause problems. To minimize inductance and ground loops, the lengths of the leads indicated by heavy lines in Figure 4&5 below should be kept as short as possible. Single point grounding (as indicated in figure 4&5) or ground plane construction should be used for best results. When using the Adjustable version, place the programming resistors as close as possible to AT2575, to keep the sensitive feedback wiring short.

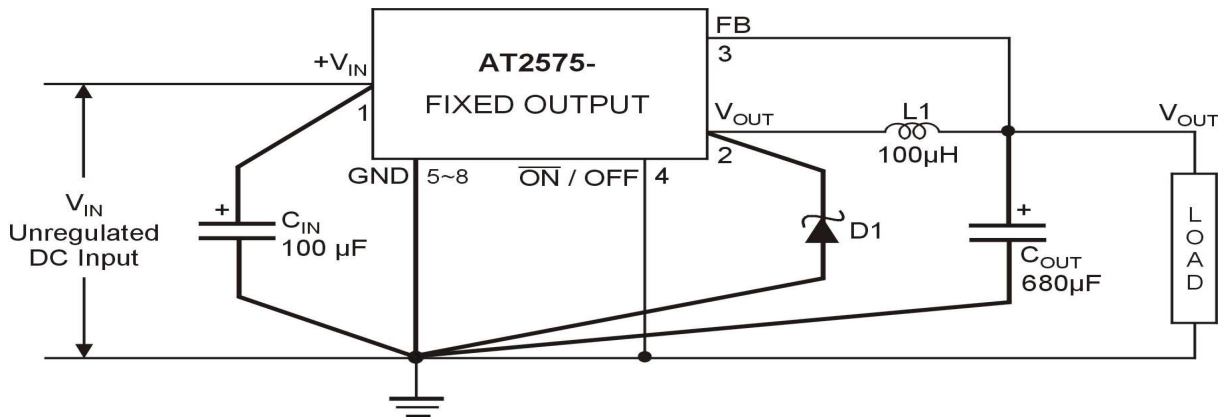

Figure 4. Fixed Output Voltage Versions

C_{IN} = 100µF, Aluminum Electrolytic
 C_{OUT} = 680µF, 25V, Aluminum Electrolytic
 D1 = Schottky
 L1 = 100µH

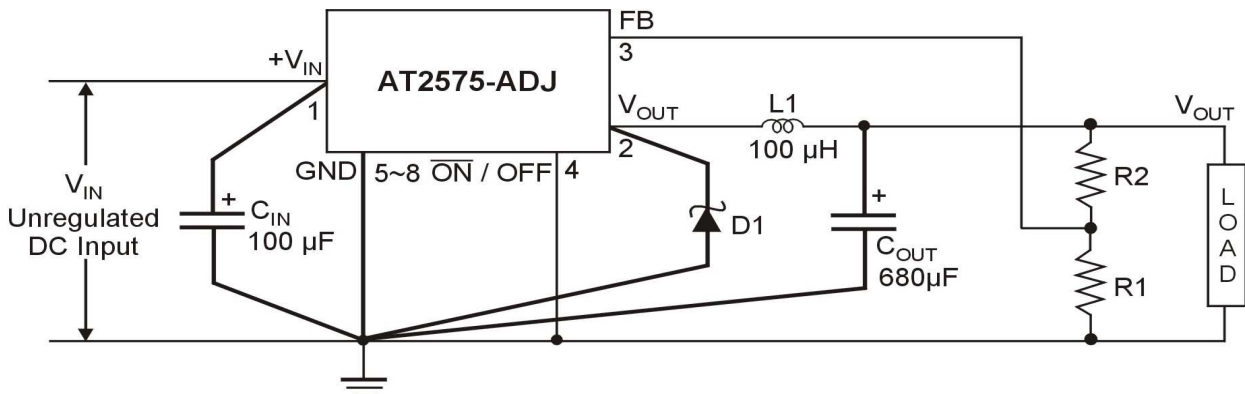

Figure 5. Adjustable Output Voltage Versions

C_{IN} = 100µF, Aluminum Electrolytic
 C_{OUT} = 680µF, 25V, Aluminum Electrolytic
 D1 = Schottky
 L1 = 100µH

$$V_{OUT} = V_{REF} \left(1 + \frac{R2}{R1} \right)$$

Where V_{REF} = 1.23V, R1 between 1K and 5K.

APPLICATION INFORMATION

Input Capacitor (C_{IN})

To maintain stability, the regulator input pin must be by-passed with at least a 47μF electrolytic capacitor. The capacitor's leads must be kept short, and located near the regulator.

If the operating temperature range includes temperatures below -25°C, the input capacitor value may need to be larger. With most electrolytic capacitors, the capacitance value decreases and the ESR increases with lower temperatures and age. Paralleling a ceramic or solid tantalum capacitor will increase the regulator stability at cold temperatures. For maximum capacitor operating lifetime, the capacitor's RMS ripple current rating should be greater than

$$1.2 \times \left(\frac{t_{ON}}{T}\right) \times I_{LOAD} = V_{REF} \left(1 + \frac{R2}{R1}\right)$$

Where $\frac{t_{ON}}{T} = \frac{V_{OUT}}{V_{IN}}$ for a buck regulator

and $\frac{t_{ON}}{T} = \frac{|V_{OUT}|}{|V_{OUT}| + V_{IN}}$ for a buck - boost regulator.

Inductor Selection

All switching regulators have two basic modes of operation: continuous and discontinuous. The difference between the two types relates to the inductor current, whether it is flowing continuously, or if it drops to zero for a period of time in the normal switching cycle. Each mode has distinctively different operating characteristics, which can affect the regulator performance and requirements.

AT2575 can be used for both continuous and discontinuous modes of operation.

The peak-to-peak inductor ripple current will be approximately 20% to 30% of the maximum DC current.

With relatively heavy load currents, the circuit operates in the continuous mode (inductor current always flowing), but under light load conditions, the circuit should be forced to the discontinuous mode (inductor current falls to zero for a period of time). This discontinuous mode of operation is perfectly acceptable. For light loads (less than approximately 200mA) it may be desirable to operate the regulator in the discontinuous mode, primarily because of the lower inductor values required for the discontinuous mode.

The inductor chooses should be values suitable for continuous mode operation, but if the inductor value chosen is prohibitively high, the designer should investigate the possibility of discontinuous operation. Inductors are available in different styles such as pot core, toriod, E-frame, bobbin core, etc., as well as different core materials, such as ferrites and powdered iron. The least expensive, the bobbin core type, consists of wire wrapped on a ferrite rod core. This type of construction makes for an inexpensive inductor, but since the magnetic flux is not completely contained within the core, it generates more electromagnetic interference (EMI). This EMI can cause problems in sensitive circuits, or can give incorrect scope readings because of induced voltages in the scope probe.

The inductors listed in the selection chart include ferrite pot core construction for AIE, powdered iron toroid for Pulse Engineering, and ferrite bobbin core for Renco.

APPLICATION INFORMATION (CONTINUED)

An inductor should not be operated beyond its maximum rated current because it may saturate. When an inductor begins to saturate, the inductance decreases rapidly and the inductor begins to look mainly resistive (the DC resistance of the winding). This will cause the switch current to rise very rapidly. Different inductor types have different saturation characteristics, and this should be kept in mind when selecting an inductor.

The inductor manufacturer's data sheets include current and energy limits to avoid inductor saturation.

Inductor Ripple Current

When the switcher is operating in the continuous mode, the inductor current waveform ranges from a triangular to a sawtooth type of waveform (depending on the input voltage). For a given input voltage and output voltage, the peak-to-peak amplitude of this inductor current waveform remains constant. As the load current rises or falls. The average DC value of this waveform is equal to the DC load current (in the buck regulator configuration).

If the load current drops to a low enough level, the bottom of the sawtooth current waveform will reach zero, and the switcher will change to a discontinuous mode of operation. This is a perfectly acceptable mode of operation. Any buck switching regulator (no matter how large the inductor value is) will be forced to run discontinuous if the load current is light enough.

Output Capacitor

An output capacitor is required to filter the output voltage and is needed for loop stability. The capacitor should be located near the AT2575 using short pc board traces. Standard aluminum electrolytics are usually adequate, but low ESR types are recommended for low output ripple voltage and good stability. The ESR of a capacitor depends on many factors, some which are: the value, the voltage rating, physical size and the type of construction. In general, low value or low voltage (less than 12V) electrolytic capacitors usually have higher ESR numbers.

The amount of output ripple voltage is primarily a function of the ESR (Equivalent Series Resistance) of the output capacitor and the amplitude of the inductor ripple current (ΔI_{IND}).

The lower capacitor values (220 μ F-680 μ F) will allow typically 50mV to 150mV of output ripple voltage, while larger-value capacitors will reduce the ripple to approximately 20mV to 50mV.

$$\text{Output Ripple Voltage} = (\Delta I_{IND})(\text{ESR of } C_{OUT})$$

To further reduce the output ripple voltage, several standard electrolytic capacitors may be paralleled, or a higher-grade capacitor may be used.

Such capacitors are often called "high-frequency," "low-inductance," or "low-ESR." These will reduce the output ripple to 10mV or 20mV. However, when operating in the continuous mode, reducing the ESR below 0.05 Ω can cause instability in the regulator.

Tantalum capacitors can have a very low ESR, and should be carefully evaluated if it is the only output capacitor.

APPLICATION INFORMATION (CONTINUED)

Because of their good low temperature characteristics, a tantalum can be used in parallel with aluminum electrolytics, with the tantalum making up 10% or 20% of the total capacitance.

The capacitor's ripple current rating at 52KHz should be at least 50% higher than the peak-to-peak inductor ripple current.

Catch Diode

Buck regulators require a diode to provide a return path for the inductor current when the switch is off. This diode should be located close to the AT2575 using short leads and short printed circuit traces.

Because of their fast switching speed and low forward voltage drop, Schottky diodes provide the best efficiency, especially in low output voltage switching regulators (less than 5V). Fast-Recovery, High-Efficiency, or Ultra-Fast Recovery diodes are also suitable, but some types with an abrupt turn-off characteristic may cause instability and EMI problems. A fast-recovery diode with soft recovery characteristics is a better choice. Standard 60Hz diodes (e.g., 1N4001 or 1N5400, etc.) are also **not suitable**.

Output Voltage Ripple and Transients

The output voltage of a switching power supply will contain a sawtooth ripple voltage at the switcher frequency, typically about 1% of the output voltage, and may also contain short voltage spikes at the peaks of the sawtooth waveform.

The output ripple voltage is due mainly to the inductor sawtooth ripple current multiplied by the ESR of the output capacitor.

The voltage spikes are present because of the fast switching action of the output switch, and the

parasitic inductance of the output filter capacitor.

To minimize these voltage spikes, special low inductance capacitors can be used, and their lead lengths must be kept short. Wiring inductance, stray capacitance, as well as the scope probe used to evaluate these transients, all contribute to the amplitude of these spikes.

An additional small LC filter (20 μ H & 100 μ F) can be added to the output to further reduce the amount of output ripple and transients. A 10 x reduction in output ripple voltage and transients is possible with this filter.

Feedback Connection

The AT2575 (fixed voltage versions) feedback pin must be wired to the output voltage point of the switching power supply. When using the adjustable version, physically locate both output voltage programming resistors near the AT2575 to avoid picking up unwanted noise. Avoid using resistors greater than 100K Ω because of the increased chance of noise pickup.

$\overline{\text{ON/OFF}}$ Input

For normal operation, the $\overline{\text{ON/OFF}}$ pin should be grounded or driven with a low-level TTL voltage (typically below 1.6V). To put the regulator into standby mode, drive this pin with a high-level TTL or CMOS signal. The $\overline{\text{ON/OFF}}$ pin can be safely pulled up to +V_{IN} without a resistor in series with it. The pin should not be left open.

AT2575

2A Step Down Voltage Switching Regulators



Immense Advance Tech.

PACKAGE OUTLINE DIMENSIONS SOP-8 PACKAGE OUTLINE DIMENSIONS

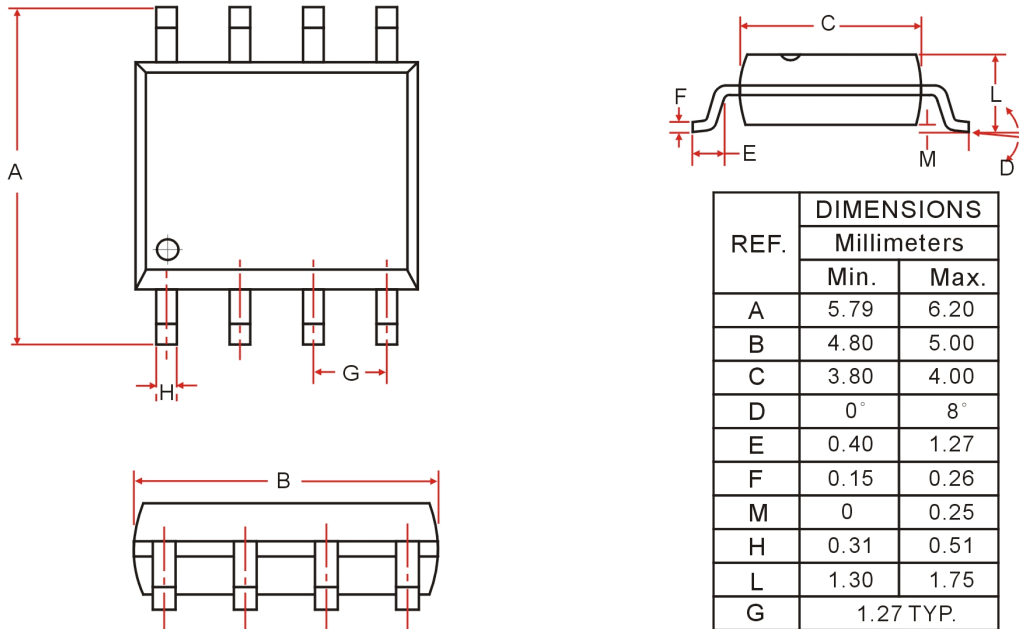

SOP-8 PACKAGE FOOTPRINT (mm)

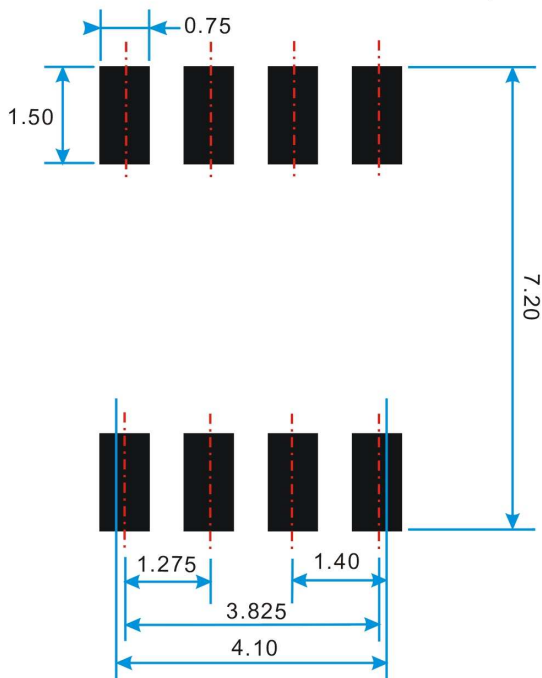

Note :

Information provided by IAT is believed to be accurate and reliable. However, we cannot assume responsibility for use of any circuitry other than circuitry entirely embodied in an IAT product; nor for any infringement of patents or other rights of third parties that may result from its use. We reserve the right to change the circuitry and specifications without notice.

Life Support Policy: IAT does not authorize any IAT product for use in life support devices and/or systems. Life support devices or systems are devices or systems which, (I) are intended for surgical implant into the body or (II) support or sustain life, and whose failure to perform, when properly used in accordance with instructions for use provided in the labeling, can be reasonably expected to result in a significant injury to the user. Typical numbers are at 25°C and represent the most likely norm.