

Features

- 11-bit ADC Temp-to-Digital Converter with 0.125°C Resolution
- Temperature Sensor Compliant with Jedec JC42.4
- Two-wire Serial Interface: I²C/SMBus™ compatible
 - SMBus™ Timeout supported
- B-grade Accuracy
 - ±1°C (max) for +75°C to +95°C
 - ±2°C (max) for +40°C to +125°C
 - ±3°C (max) for -20°C to +125°C
- Optimized for voltage range: 2.7V to 3.6V
- 100khz and 400khz Compatibility
- Up to Eight Devices on a Single Bus
- Versatile Alarm Output with Programmable Trip Temperatures
- Programmable hysteresis threshold: off, 0°C, 1.5°C, 3°C, 6 °C
- Schmitt Trigger, filtered inputs for Noise Suppression
- Low Operating current
 - Temperature Sensor Active ~ 0.2mA (typ.)
- Industry Standard Green (Pb/Halide-free/RoHS Compliant) Package Options
 - 8-pad Very Very Thin DFN (2 x 3 x 0.8mm)

Description

The Atmel® AT30TS00 combines a temperature sensor, programmable over-temperature alarms, and a 2-wire I²C/SMBus compatible serial interface into single compact packages specifically designed for DRAM memory module applications. However, the AT30TS00 is ideal for many other applications. The AT30TS00 converts its die temperature into digital values using internal analog-to-digital converters (ADCs). The result of the conversion is held in a temperature register and is readable at any time through the serial interface. The temperature sensor converts temperatures from -20°C to +125°C to a digital word and provides an accuracy of ±1°C (max.) in the temperature range +75°C to +95°C. The temperature sensor continuously monitors temperature and updates data in the temperature register at least 8 times per second.

The AT30TS00 supports the industry standard 2-wire I²C/ SMBus serial Interface to include a time out feature to help prevent system lock-ups.

The AT30TS00 has flexible user programmable internal registers to configure the temperature sensor performance and response to over temperature conditions. The device contains programmable high, low, and critical temperature limits. A dedicated alarm output, $\overline{\text{EVENT}}$, activates if the conversion result exceeds the value programmed in the high temperature register. The device $\overline{\text{EVENT}}$ pin is configured as active low and can be configured to operate as an interrupt or as a comparator output.

The AT30TS00 features a shutdown mode that saves power by turning off everything but the power-on reset and the 2-wire interface. The AT30TS00 $\overline{\text{EVENT}}$ and SDA pins are open-drains and require connection of a suitable external pull-up resistor.



Digital Temperature Sensor with Two-Wire Interface

Atmel AT30TS00

Preliminary



Figure 0-1. Pin Configuration

Pin Name	Description
A0 – A2	Address Inputs
SDA	Serial Data
SCL	Serial Clock Input
Temperature Alert	$\overline{\text{EVENT}}$
GND	Ground
V_{CC}	Power Supply

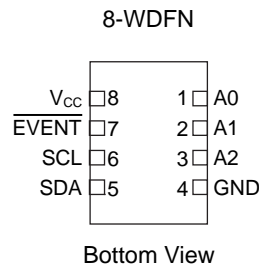

1. *Absolute Maximum Ratings

Operating Temperature.....	- 40°C to +125°C
Storage Temperature	- 65°C to + 150°C
Voltage on Any Pin with Respect to Ground	- 1.0 V +5.0V
Pin A0	- 1.0 V +12V
Maximum Operating Voltage.....	4.3V
DC Output Current.....	5.0 mA

*NOTICE: Stresses beyond those listed under “Absolute Maximum Ratings” may cause permanent damage to the device. This is a stress rating only and functional operation of the device at these or any other conditions beyond those indicated in the operational sections of this specification are not implied. Exposure to absolute maximum rating conditions for extended periods may affect device reliability.

Two-wire Digital Temperature Sensor

Figure 1-1. Block Diagram

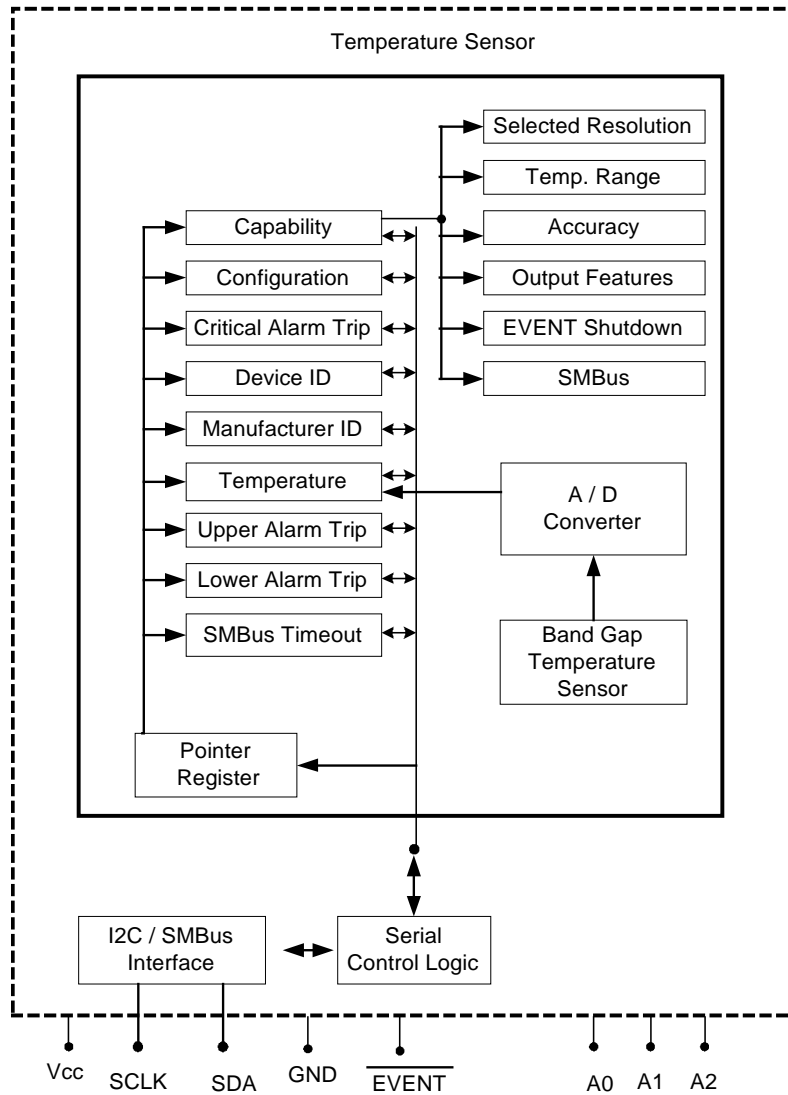

2. Pin Descriptions

SERIAL CLOCK (SCL):

The SCL input is used to positive edge clock data into each device and negative edge clock data out of each device.

SERIAL DATA (SDA):

The SDA pin is bidirectional for serial data transfer. This pin is open drain driven and may be wire-ORed with any number of other open-drain or open collector devices.

Device Addresses (A2, A1, A0): The A2, A1, and A0 pins are device address inputs that are hardwired (directly to GND or to V_{CC}) for compatibility with two-wire devices. If these pins are left floating, the A2, A1, and A0 pins will be internally pulled to GND. However, Atmel® recommends always connecting the address pins to a known state by direct connection to ground or V_{CC} .

Temperature Alert Output (\overline{EVENT}): The \overline{EVENT} Pin outputs a signal when the temperature goes beyond the user-programmed temperature limit. The \overline{EVENT} Pin is an open-drain output and can be programmed as an interrupt, critical alarm or comparator mode.

Table 2-1. Pin Capacitance(1)

Applicable over recommended operating range from $T_A = 25^\circ\text{C}$, $f = 100\text{kHz}$, $V_{CC} = +3.0\text{V}$

Symbol	Test Condition	Max	Units	Conditions
$C_{I/O}$	Input/Output Capacitance (SDA), \overline{EVENT}	8	pF	$V_{I/O} = 0\text{V}$
C_{IN}	Input Capacitance (A ₀ , A ₁ , A ₂ , SCL)	6	pF	$V_{IN} = 0\text{V}$

Note: 1. This parameter is ensured by characterization only

Table 2-2. DC Characteristics

Applicable over recommended operating range: $T_A = -20^\circ\text{C}$ to $+125^\circ\text{C}$, $V_{CC} = +2.7\text{V}$ to $+3.6\text{V}$ (unless otherwise noted)

Symbol	Parameter	Test Condition	Min	Typ	Max	Units
V_{CC1}	Supply Voltage		2.7		3.6	V
Supply Current						
I_{CC}	Temp. Sensor $V_{CC} = 3.6\text{V}$	Temp. Sensor active		0.2	0.5	mA
I_{CC}	Timeout active $V_{CC} = 3.6\text{V}$	Temp. Sensor shutdown		0.2	0.5	mA
I_{SB}	Standby Current $V_{CC} = 3.6\text{V}^{(2)}$	$V_{in} = V_{HV} = \text{or } V_{SS}$		1.6	4.0	μA
I_{LI}	Input Leakage Current	$V_{in} = V_{HV} = \text{or } V_{SS}$		0.1	2.0	μA
I_{LO}	Output Leakage Current	$V_{out} = V_{HV} = \text{or } V_{SS}$		0.1	2.0	μA
V_{IL}	Input Low Level ⁽¹⁾		-0.6		$V_{HV} \times 0.3$	V
V_{IH}	Input High Level ⁽¹⁾		$V_{HV} \times 0.7$		$V_{HV} + 0.5$	V
V_{OL}	Output Low level $V_{CC} = 3.0\text{V}$	$I_{OL} = 2.1\text{mA}$			0.4	V

Table continued...

Two-wire Digital Temperature Sensor

Table 2-2. DC Characteristics continued

Symbol	Parameter	Test Condition	Min	Typ	Max	Units
Temperature Sensor Accuracy						
T_{ACCUR}	+75°C < Ta < +95°C		-1.0	±0.5	+1.0	°C
T_{ACCUR}	+40°C < Ta < +125°C		-2.0	±1	+2.0	°C
T_{ACCUR}	-20°C < Ta = +125°C		-3.0	±2	+3.0	°C
T_{CONV}	Temp. Sensor Conversion Time			75	125	ms
T_{RES}	Temp. Sensor Resolution			0.25		°C

- Note: 1. V_{il} min and V_{ih} max are reference only and are not tested
 2. Sensor in Shutdown Mode

Table 2-3. AC Characteristics

Applicable over recommended operating range:

$T_{\text{AI}} = -20^{\circ}\text{C}$ to $+125^{\circ}\text{C}$, $V_{\text{CC}} = +2.7\text{v}$ to $+3.6\text{V}$, $\text{CL} = 1$ TTL Gate and $100\mu\text{F}$ (unless otherwise noted)

Symbol	Parameter	Min	Max	Min	Max	Units
f_{SCL}	Clock Frequency, SCL	10 ⁽²⁾	100	10 ⁽²⁾	400	kHz
t_{LOW}	Clock Pulse Width Low	4.7		1.2		μs
t_{HIGH}	Clock Pulse Width High	4.0		0.6		μs
t_{I}	Noise Suppression Time ⁽¹⁾		100		50	ns
$T_{\text{HD,DI}}$	Data In Hold Time	0		0.0		us
t_{BUF}	Time the bus must be free before a new transmission can start ⁽¹⁾	4.7		1.2		μs
$t_{\text{HD,STA}}$	Start Hold Time	4.0		0.6		μs
$t_{\text{SU,STA}}$	Start Set-up Time	4.7		0.6		μs
$t_{\text{HD,DAT}}$	Data In Hold Time	0		0.0		μs
$t_{\text{SU,DAT}}$	Data In Set-up Time	200		100		ns
t_{R}	Inputs Rise Time ⁽¹⁾		1.0		0.3	μs
t_{F}	Inputs Fall Time ⁽¹⁾		300		300	ns
$t_{\text{SU,STO}}$	Stop Set-up Time	4.7		0.6		μs
t_{DH}	Data Out Hold Time	100		50		ns
t_{OUT}	SMBus Timeout Time	25	35	25	35	ms

- Note: 1. This parameter is ensured by characterization only
 2. The minimum frequency is specified at 10Khz to avoid activating the timeout feature

3. Device Operation

- CLOCK and DATA TRANSITIONS:** The SDA pin is normally pulled high with an external device. Data on the SDA pin may change only during SCL low time periods (see Figure 3-3). Data changes during SCL high periods will indicate a start or stop condition as defined below.
- START CONDITION:** A high-to-low transition of SDA with SCL high is a start condition which must precede any other command (see Figure 3-4).
- STOP CONDITION:** A low-to-high transition of SDA with SCL high is a stop condition. After a read sequence, the stop command will place the device in a standby power mode (see Figure 3-4).
- ACKNOWLEDGE:** All addresses and data words are serially transmitted to and from the device in 8-bit words. The device sends a zero to acknowledge that it has received each word. This happens during the ninth clock cycle.
- STANDBY MODE:** The Atmel® AT30TS00 features a low-power standby mode which is enabled:
- Upon power-up
 - After the receipt of the STOP bit and the completion of any internal operations. The temperature sensor must be disabled by the user for low-power standby mode.
- Two-Wire Software Reset:** After an interruption in protocol, power loss or system reset, any two-wire part can be reset by following these steps:
- Create a start bit condition
 - Clock nine cycles
 - Create another start bit followed by stop bit condition as shown below. The device is ready for next communication after the above steps have been completed.

Figure 3-1. Two-Wire Software Reset

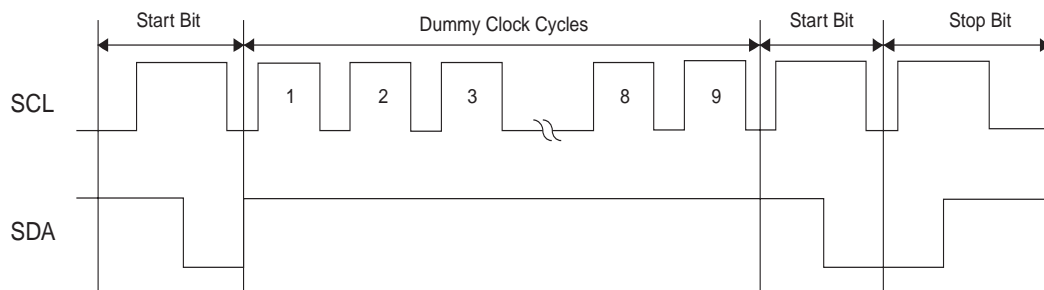

Two-wire Digital Temperature Sensor

Figure 3-2. Bus Timing SCL: Serial Clock SDA: Serial Data I/O

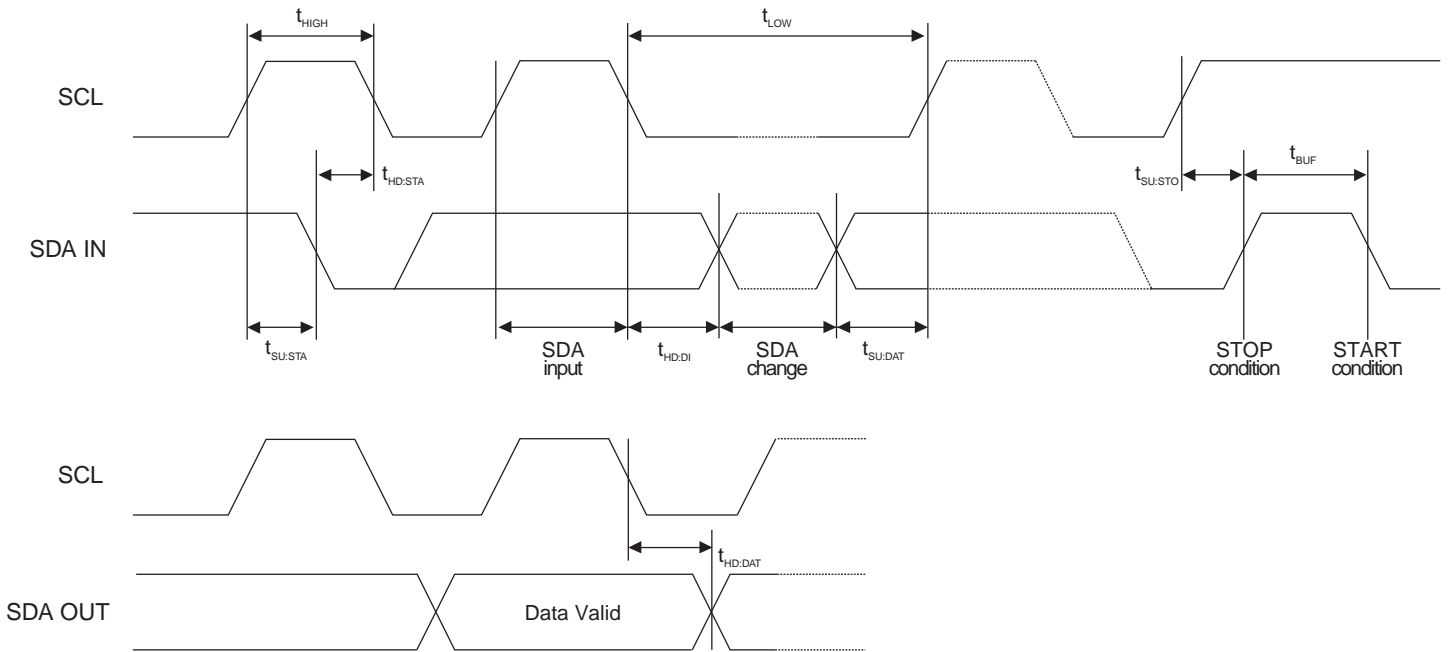

Figure 3-3. Data Validity

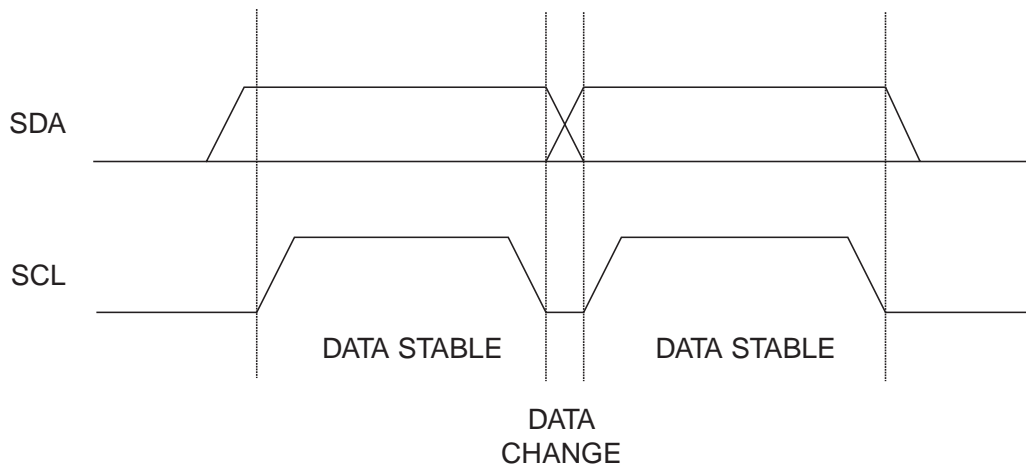

Figure 3-4. Start and Stop Condition

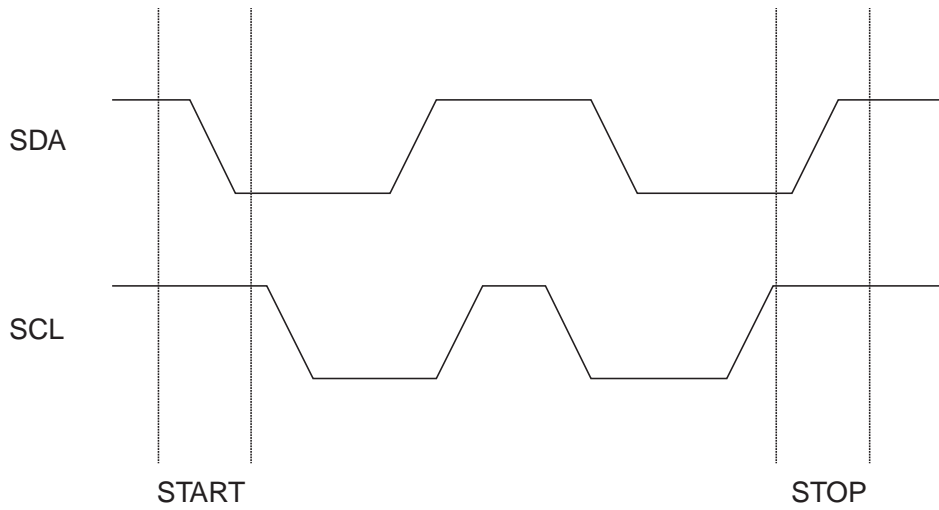
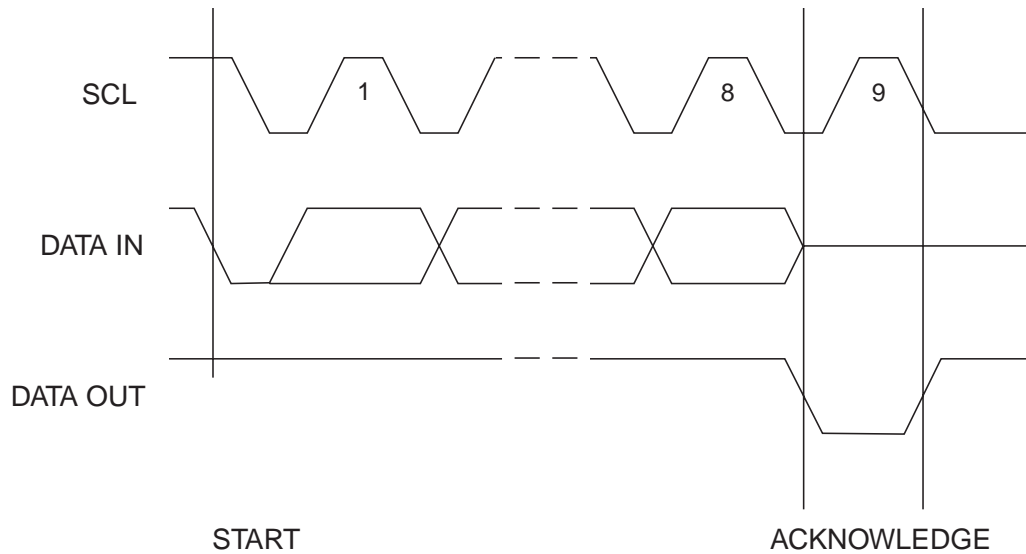

Figure 3-5. Output Acknowledge



4. Device Addressing

The Atmel® AT30TS00 device requires an 8-bit device address word following a start condition to enable the chip to access either the Temperature Sensor functions (See Table 4-1).

Table 4-1. Control/Device Address Word

Device	Control / Device Address Word							
	Device ID				Device Address Bits			R/W
	B7	B6	B5	B4	A2	A1	A0	B0
Temperature Sensor	0	0	1	1	X	X	X	X

Note: X = User Selectable

The device address word consists of a mandatory “0011” sequence for the first four most significant bits for Temperature Sensor operations. The next three bits are the A2, A1 and A0 device address bits for the AT30TS00 device. These three bits must match their corresponding hard-wired input pins. The eighth bit of the device address is the read/write operation select bit. A read operation is initiated if this bit is high. Upon a compare of the device address, the device will output a zero, called an Acknowledge (ACK). If a compare is not made, the chip will not ACK and will return to a standby state.

5. Temperature Sensor Functional Description

The AT30TS00 consists of a Delta-Sigma Analog to Digital Converter (ADC) with a band gap type temperature sensor that monitors and updates its own temperature reading at least 8 times per second converting the readings into digital data bits and latching them into a temperature register that can be read via 2-wire I²C/SMBus serial interface. The device communicates over a 2-wire I²C/SMBus interface with the bus master or controller consisting of a serial clock (SCL) and serial bidirectional data bus (SDA) with clock frequencies up to 400Khz. The bus master or controller generates the SCL signal and is used by the AT30TS00 to receive and send serial data on the SDA line with the most significant bit transferred first. A pull-up resistor is required on the SDA pin since it is in an open drain configuration.

5.1. EVENT Output

The $\overline{\text{EVENT}}$ pin has three operating modes depending on configuration settings. They are Interrupt, Comparator, and Critical Alarm (Crit_Alarm) modes.

In the Interrupt mode, once a temperature reaches a boundary limit, the AT30TS00 asserts the $\overline{\text{EVENT}}$ pin. The $\overline{\text{EVENT}}$ pin will remain asserted until software clears the interrupt by writing a “1” to the EVTCLR bit five in the configuration register. When the temperature drops below specified limits, the device returns back to either interrupt or comparator mode as programmed in the configuration register’s EVTMOD bit 0.

In the comparator mode, the $\overline{\text{EVENT}}$ pin remains asserted until the error condition that caused the pin to be asserted no longer exists and the $\overline{\text{EVENT}}$ pin will clear itself. In the Crit_Alarm mode, when the measured temperature exceeds Crit_Alarm trip limit, the $\overline{\text{EVENT}}$ pin will remain asserted until the temperature drops below Crit_Alarm limit minus hysteresis (See Figure 6-1). All event thresholds use hysteresis as programmed in the configuration register.

5.2. Alarm Window

The alarm window consists of the Upper Alarm Trip Register and Lower Alarm Trip Register. The Upper Alarm Trip Register holds the upper temperature trip point and the Lower Alarm Trip Register holds the lower temperature trip point. After the $\overline{\text{EVENT}}$ pin control is enabled, the $\overline{\text{EVENT}}$ output will be triggered upon entering and exiting from this window.



5.3. Temperature Sensor Power-on Default

The Atmel® AT30TS00 has an internal Power-on Reset (POR) circuit. When the supply voltage drops below the POR threshold, the device will reset to the following power-on default conditions:

- Sensor starts monitoring temperature continuously
- Address Pointer Register = 00h
- Upper / Lower Alarm Trip registers and Crit_Alarm registers are set to 0°C
- $\overline{\text{EVENT}}$ register cleared and pulled high by external pull up resistor
- Operational mode is Comparator
- $\overline{\text{EVENT}}$ hysteresis is 0°C
- SMBus register =00h

5.4. Device Initialization

The AT30TS00 Temperature Sensor has programmable registers that, upon device power-on, are initialized to '0'. Table 6-1 shows the power-on register default values. The $\overline{\text{EVENT}}$ output is defaulted to deasserted state and comparator mode. Please note the Upper Alarm Trip, Lower Alarm Trip, Critical Alarm Trip registers and Configuration registers need to be programmed to the desired values before temperature sensor can properly function.

5.5. SMBus Timeout

The AT30TS00 supports the SMBus timeout feature if enabled via setting the SMBus register. (see Section 6.10) This feature helps prevent potential system bus hang-ups by resetting the serial interface if SCL stays low for a time specified by the t_{OUT} parameter. This requires a minimum SCL clock speed of 10Khz as specified in the SMBus specification to avoid any timeout issues.

6. Register Descriptions

This section describes all the temperature sensor registers that are used in the Atmel® AT30TS00. The AT30TS00 has several registers that are user accessible and or programmable and used for latching temperature readings, storing high and low temperature limits, configuring the hysteresis threshold and reporting status.

These registers include the Capability Register, Upper Alarm Trip Register, Lower Alarm Trip Register, Critical Alarm Trip Register, Temperature Register, Manufacturer Identification Register, Device Identification Register and SMBus Register. The AT30TS00 uses an 8-bit Pointer Register to access these 16-bit data registers.

Table 6-1 below, indicates the Write / Read access capability of each register. Please note that reading from a write only register will result in reading '0' data and writing to read only register will have no impact even though the write sequence was acknowledged by the device.

Table 6-1. Register Summary

Registers				Power up Default Register data (hex)
Address (hex)	Read / Write	Register Name	Section	
n/a	W	Address Pointer	6.1	00h
00h	R	Capability	6.2	00D7h
01h	R / W	Configuration	6.3	0000h
02h	R / W	Upper Alarm Trip	6.4	0000h
03h	R / W	Lower Alarm Trip	6.5	0000h
04h	R / W	Critical Alarm Trip	6.6	0000h
05h	R	Temperature Data	6.7	n/a
06h	R	Manufacturer I.D.	6.8	001Fh
07h	R	Device I.D. / Device Revision	6.9	8201h
08h to 21h	R / W	Reserved ⁽¹⁾	n/a	0000h
22h	R	SMBus Timeout	6.10	0000h
23h to FFh	R / W	Reserved ⁽¹⁾	n/a	0000h

Note: 1. Write operations to reserve registers should be avoided as it may cause undesirable results

6.1. Address Pointer Register

The AT30TS00 uses a Pointer Register to select and access the 16-bit data registers shown in Table 6-1. The Pointer Register is an 8-bit write only register (See Table 6-2). The power on default value is 00h which is the address location for the capability register.

Table 6-2. Address Pointer Register

Bit	7	6	5	4	3	2	1	0
Symbol	Pointer Bits							
R / W	W	W	W	W	W	W	W	W
Default Value	0	0	0	0	0	0	0	0

6.2. Capability Register (16-bit Read only, Address = 00h)

The Atmel® AT30TS00 is capable of measuring temperature with $\pm 1^{\circ}\text{C}$ over the active range and $\pm 2^{\circ}\text{C}$ over the monitor range. This register is a 16-bit read-only register used to specify the capabilities of the temperature sensor. The capability register functions are described in Table 6-3 and Table 6-4.

Table 6-3. Capability Register Bit Distribution

Bit	15	14	13	12	11	10	9	8
Symbol	RFU							
Default Value	0	0	0	0	0	0	0	0
R / W access	R	R	R	R	R	R	R	R
Bit	7	6	5	4	3	2	1	0
Symbol	EVSD	TMOUT	RFU	TPRES		RANGE	SACC	ICAP
Default Value	1	1	0	1	0	1	1	1
R / W access	R	R	R	R	R	R	R	R

Table 6-4. Capability Register Bit Description

Bit	Symbol	Description
15:8	RFU	Reserved for Future Use and must be '0'
7	EVSD	1 = The $\overline{\text{EVENT}}$ pin is deasserted (not driven) when entering shutdown mode, and upon exiting shutdown mode, the $\overline{\text{EVENT}}$ pin goes back to previous state it was in prior to shutdown mode and will be updated after one thermal conversion cycle
6	TMOUT	1 = Parameter t_{OUT} is supported within the range of 25 to 35mS (SMBus compatible) Please note the SMBus Timeout feature is supported in shutdown mode and will consume more current if Timeout is engaged but not timed out (see Icc parameter in DC Characteristics)
5	RFU	Reserved for Future Use and must be '0'
4:3	TPRES	Temperature resolution '10' – supports 0.125°C
2	RANGE	'1' – Can read temperatures below 0°C and sets appropriate sign bit
1	SACC	Supported Accuracy. '1' – Supports B grade accuracy of $\pm 1^{\circ}\text{C}$ over the active range (75°C to 95°C) and 2°C over the monitor range (40°C to 125°C)
0	ICAP	Interrupt Capability. '1' – has alarm and critical trip interrupt capability

Two-wire Digital Temperature Sensor

6.3. Configuration Register (16-bit Read/Write, Address = 01h)

The Atmel® AT30TS00 contains a 16-bit configuration register allowing the user to set key operational features of the temperature sensor. The configuration register functions are described in Table 6-5 and Table 6-6.

Table 6-5. Configuration Register Bit Distribution

Bit	15	14	13	12	11	10	9	8
Symbol	RFU					HYSTENB		SHTDWN
Default Value	0	0	0	0	0	0	0	0
R / W access	R	R	R	R	R	R/W	R/W	R/W
Bit	7	6	5	4	3	2	1	0
Symbol	CRTALML	WINLOCK	EVTCLR	EVTSTS	EVTOUT	CRITEVT	EVTPOL	EVTMOD
Default Value	0	0	0	0	0	0	0	0
R / W access	R/W	R/W	W	R	R/W	R/W	R	R/W

Table 6-6. Configuration Register Bit Description

Bit	Symbol	Description
15:11	RFU	Reserved for Future Use and must be '0'
10:9	HYSTENB	<p>Hysteresis Enable</p> <p>'00' = 0°C Disable hysteresis (default power-on condition)</p> <p>'01' = 1.5°C Enable hysteresis</p> <p>'10' = 3.0°C Enable hysteresis</p> <p>'11' = 6.0°C Enable hysteresis</p> <p>The purpose of these bits is to control the hysteresis applied to the alarm trip point boundaries. The above hysteresis applies to all limits when temperature drops below the user specified alarm trip points. Please note that hysteresis applies to decreasing temperature only. Once ambient temperature is above a given threshold, it must drop below the boundary limit minus hysteresis in order for a comparator $\overline{\text{EVENT}}$ to be cleared.</p> <p>For example: If these bits are set to '01' for 1.5°C and the Upper Alarm Trip limit is set to 85°C, as temperature rises above 85°C, bit 14 of temperature register will be set to a '1'. Bit 14 will remain set until the ambient temperature drops below the threshold (85°C) minus the hysteresis value or 83.5°C.</p> <p>Note: Hysteresis is also applied to the $\overline{\text{EVENT}}$ pin functionality. When either of the Crit_Alarm Trip or Alarm Window lock bits is set, this bit cannot be altered until unlocked</p>
8	SHTDWN	<p>Shutdown Mode</p> <p>0 = Temperature sensor enabled for continuous conversion (power-on default)</p> <p>1 = Temperature sensor disabled</p> <p>In Shutdown mode, the temperature sensor is not active and will not generate interrupts or update temperature data. The $\overline{\text{EVENT}}$ pin is deasserted (not driven).</p> <p>When either of the Crit_Alarm Trip or Alarm Window lock bits is set, this bit cannot be altered until unlocked.</p>



Bit	Symbol	Description
7	CRTALML	<p>Crit_Alarm Trip Lock bit</p> <p>Locks the Critical Alarm Trip register from being updated</p> <p>0 = Crit_Alarm Trip register can be updated (Power-on default)</p> <p>1 = Crit_Alarm Trip register is locked and cannot be updated</p> <p>Once set, it can be only be cleared to '0' by internal power on reset (POR) which occurs when the device is powered off and then powered on</p>
6	WINLOCK	<p>Alarm Window Lock bit</p> <p>0 = Upper and Lower Alarm Trip Registers can be updated (Power-on default)</p> <p>1 = Upper and Lower Alarm Trip Registers are locked and cannot be updated</p> <p>Once set, it can be only be cleared to '0' by internal power on reset (POR) when device is powered off then powered on</p>
5	EVTCLR	<p>$\overline{\text{EVENT}}$ Clear. This bit is a Write only bit and will read '0'</p> <p>This bit can clear the $\overline{\text{EVENT}}$ pin after it has been enabled and is self clearing</p> <p>'0' = has no effect (power-on default)</p> <p>'1' = clears (releases) the active $\overline{\text{EVENT}}$ pin in interrupt mode. This bit is ignored when in comparator mode</p>
4	EVTSTS	<p>$\overline{\text{EVENT}}$ Status. This is a Read only bit</p> <p>This bit indicates if the $\overline{\text{EVENT}}$ Output is asserted by the device</p> <p>'0' = The $\overline{\text{EVENT}}$ pin is not asserted. (Power-on default)</p> <p>'1' = The device is asserting (drives low) the $\overline{\text{EVENT}}$ output due to Alarm trip condition</p>
3	EVTOUT	<p>$\overline{\text{EVENT}}$ Output Control</p> <p>This bit, when set, prevents the $\overline{\text{EVENT}}$ pin from generating an interrupt</p> <p>0 = The $\overline{\text{EVENT}}$ output is disabled and will not generate interrupts (Power-on default)</p> <p>1 = The $\overline{\text{EVENT}}$ output is enabled</p> <p>When either of the Crit_Alarm Trip or Alarm Window lock bits is set, this bit cannot be altered until unlocked</p>
2	CRITEVT	<p>Critical Temperature only</p> <p>0 = The $\overline{\text{EVENT}}$ output is asserted for the Upper, Lower and Critical Alarms (Power-on default).</p> <p>1 = The $\overline{\text{EVENT}}$ output is asserted for only Critical Alarm when ambient temperature > Crit_Alarm trip boundary</p> <p>When the Alarm Window lock bit is set, this bit cannot be altered until unlocked</p>
1	EVTPOL	<p>$\overline{\text{EVENT}}$ Polarity</p> <p>0 = Active LOW. (Power-on default)</p> <p>A pull-up resistor is required on this pin to set inactive state</p> <p>1 = Active HIGH</p> <p>When either of the Crit_Alarm Trip or Alarm Window lock bits is set, this bit cannot be altered until unlocked</p>
0	EVTMOD	<p>$\overline{\text{EVENT}}$ Mode</p> <p>0 = The $\overline{\text{EVENT}}$ pin will operate in Comparator mode. (Power-on default)</p> <p>1 = The $\overline{\text{EVENT}}$ pin will operate in Interrupt mode</p> <p>When either of the Crit_Alarm Trip or Alarm Window lock bits is set, this bit cannot be altered until unlocked</p>

Two-wire Digital Temperature Sensor

Figure 6-1. $\overline{\text{EVENT}}$ Pin Mode Functionality

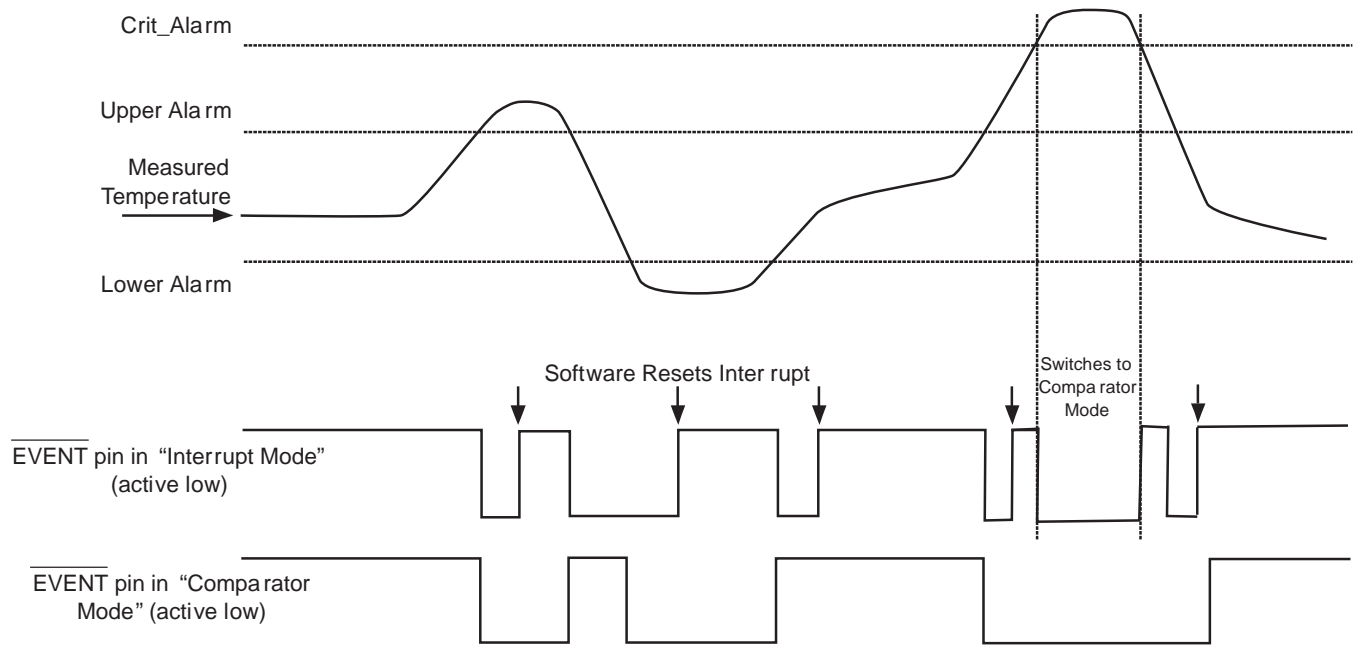

6.4. Upper Alarm Trip Register (16-bit Read/Write, Address = 02h)

The Upper Alarm Trip Register holds the user programmed upper temperature boundary trip point in 11-bit two's complement format (0.25°C resolution) that can be used to monitor ambient temperature in an operating window (See Table 6-7 and Table 6-8). When the temperature increases above this trip point, or drops below or is equal to the trip point (minus any hysteresis set), then the $\overline{\text{EVENT}}$ pin is asserted (if enabled). This register becomes read only if the Alarm Window Lock bit (WINLOCK) bit 6 in the configuration register is set to a '1'.

Table 6-7. Upper Alarm Trip Register Bit Distribution

Bit	15	14	13	12	11	10	9	8
Symbol	RFU			SIGN	ALMWINH			
Default Value	0	0	0	0	0	0	0	0
R / W access	R	R	R	R/W	R/W	R/W	R/W	R/W
Bit	7	6	5	4	3	2	1	0
Symbol	ALMWINH						RFU	
Default Value	0	0	0	0	0	0	0	0
R / W access	R/W	R/W	R/W	R/W	R/W	R/W	R	R

Table 6-8. Upper Alarm Trip Register Bit Description

Bit	Symbol	Description
15:13	RFU	Reserved for future use. Read as '0'
12	SIGN	Sign bit 0 = Ambient temperature is greater than or equal to 0°C 1 = Ambient temperature is less than 0°C
11:2	ALMWINH	Upper Alarm Trip temperature bits Represented in two's complement format
1:0	RFU	Reserved for future use. Read as '0'

6.5. Lower Alarm Trip Register (16-bit Read/Write, Address = 03h)

The Lower Alarm Trip Register holds the user programmed lower temperature boundary trip point in 11-bit two's complement format (0.25°C resolution) that can be used to monitor ambient temperature in an operating window (See Table 6-9 and Table 6-10). When temperature decreases below this trip point minus any hysteresis set or increases to meet or exceed this trip point, then the $\overline{\text{EVENT}}$ pin is asserted (if enabled).

This register becomes read only if the Alarm Window Lock bit (WINLOCK) bit six in the configuration register is set to a '1'.

Table 6-9. Lower Alarm Trip Register Bit Distribution

Bit	15	14	13	12	11	10	9	8
Symbol	RFU			SIGN	ALMWINL			
Default Value	0	0	0	0	0	0	0	0
R / W access	R	R	R	R/W	R/W	R/W	R/W	R/W
Bit	7	6	5	4	3	2	1	0
Symbol	ALMWINL						RFU	
Default Value	0	0	0	0	0	0	0	0
R / W access	R/W	R/W	R/W	R/W	R/W	R/W	R	R

Table 6-10. Lower Alarm Trip Register Bit Description

Bit	Symbol	Description
15:13	RFU	Reserved for future use. Read as '0'
12	SIGN	Sign bit 0 = Ambient temperature is greater than or equal to 0°C 1 = Ambient temperature is less than 0°C
11:2	ALMWINL	Lower Alarm Trip temperature bits Represented in two's complement format
1:0	RFU	Reserved for future use. Read as '0'

6.6. Critical Alarm Trip Register (16-bit Read/Write, Address = 04h)

The Critical Alarm Trip Register holds the user programmed Critical Alarm temperature boundary trip point in 11-bit two's complement format (0.25°C resolution) that can be used to monitor ambient temperature (See Table 6-11 and Table 6-12). When the temperature increases above this trip point, the $\overline{\text{EVENT}}$ pin will be asserted (if enabled). It will remain asserted until temperature decreases below or equal to the trip point minus any hysteresis set. This register becomes read only if the Critical Alarm Trip Lock Bit (CRTALML) bit seven in the configuration register is set to a '1'.

Table 6-11. Critical Alarm Trip Register Bit Distribution

Bit	15	14	13	12	11	10	9	8
Symbol	RFU			SIGN	CRITEVT			
Default Value	0	0	0	0	0	0	0	0
R / W access	R	R	R	R/W	R/W	R/W	R/W	R/W
Bit	7	6	5	4	3	2	1	0
Symbol	CRITEVT						RFU	
Default Value	0	0	0	0	0	0	0	0
R / W access	R/W	R/W	R/W	R/W	R/W	R/W	R	R

Table 6-12. Critical Alarm Trip Register Bit Description

Bit	Symbol	Description
15:13	RFU	Reserved for future use. Read as '0'
12	SIGN	Sign bit 0 = Ambient temperature is greater than or equal to 0°C 1 = Ambient temperature is less than 0°C
11:2	CRITEVT	Critical Alarm Trip temperature bits Represented in two's complement format
1:0	RFU	Reserved for future use. Read as '0'

Two-wire Digital Temperature Sensor

6.7. Temperature Register (16-bit Read only, Address = 05h)

The temperature register holds the internal temperature measurement data represented in 11-bit 2's complement word format allowing for resolution equal to 0.125°C (least significant bit). The upper three bits (15, 14, 13) of the temperature register indicates the trip status of the current temperature and most important, are not affected by the status of the output of the $\overline{\text{EVENT}}$ pin (see Table 6-13 and Table 6-14).

Table 6-13. Temperature Register Bit Distribution

Bit	15	14	13	12	11	10	9	8
Symbol	CRITHIGH	ALMHIGH	ALMLOW	SIGN	128°C	64°C	32°C	16°C
Default Value	0	0	0	0	0	0	0	0
R / W access	R	R	R	R	R	R	R	R

Bit	7	6	5	4	3	2	1	0
Symbol	8°C	4°C	2°C	1°C	0.5°C	0.25°C	0.125°C	RFU
Default Value	0	0	0	0	0	0	0	0
R / W access	R	R	R	R	R	R	R	R

Table 6-14. Temperature Register Bit Description

Bit	Symbol	Description
15	CRITHIGH	0 = Ambient temperature is less than the Critical Alarm Trip Register setting 1 = Ambient temperature is greater than or equal to Critical Alarm Trip Register setting When this bit is set '1', it will automatically clear once the measured temperature decreases below or is equal to the trip point minus any hysteresis set
14	ALMHIGH	0 = Ambient temperature is below the Upper Alarm Trip register setting 1 = Ambient temperature is above the Upper Alarm Trip register setting When the bit is set '1', it will automatically clear once the measured temperature decreases below or is equal to the trip point minus any hysteresis set
13	ALMLOW	0 = Ambient temperature is above the Lower Alarm Trip register setting 1 = Ambient temperature is below the Lower Alarm Trip register setting When the bit is set '1', it will automatically clear once the measured temperature increases above or is to equal to the trip point
12	SIGN	Sign Bit 0 = Ambient temperature is greater than or equal to 0°C 1 = Ambient temperature is less than 0°C
11:1	TEMP	Ambient Temperature Bits Represented in two's complement format The encoding of bits B11 through B2 is the same as in the Alarm Trip registers.
0	RFU	Reserved for future use. Read as '0'.

6.7.2. Temperature Register Format

This section will clarify the temperature register format and temperature bit value assignments used for temperature for the following registers: Upper Alarm Trip, Lower Alarm Trip, Critical Alarm Trip and Temperature Data. The temperatures expressed in the Upper Alarm Trip, Lower Alarm Trip, Critical Alarm Trip and temperature registers are indicated in two's complement format. In each of the trip registers, bits 12 through bit two are used for temperature settings, or in the case of the temperature register, holds the internal temperature measurement with bits 12 through bit one allowing 0.125°C resolution.

Table 6-15 indicates the temperature register's assigned bit values used for temperature. Table 6-16 below shows examples for temperature register bit values for various temperature readings.

Table 6-15. Temperature Register Format

Bit Position	12	11	10	9	8	7	6	5	4	3	2	1	0
Bit Value	SIGN	128°C	64°C	32°C	16°C	8°C	4°C	2°C	1°C	0.5°C	0.25°C	0.125°C	X

Table 6-16. Temperature Register Examples

Temperature Register Value Examples	
Temperature	Binary (Bit15 – Bit0)
+125°C	xxx0 0111 1101 00xx
+99.75°C	xxx0 0110 0011 11xx
+85°C	xxx0 0101 0101 00xx
+39°C	xxx0 0010 0111 00xx
+15.75°C	xxx0 0000 1111 11xx
+0.25°C	xxx0 0000 0000 01xx
0°C	xxx0 0000 0000 00xx
-0.25°C	xxx1 1111 1111 11xx
-1°C	xxx1 1111 1110 00xx
-20°C	xxx1 1110 1100 00xx

6.8. Manufacturer ID Register (16-bit Read only, Address = 06h)

This register is used to identify the manufacturer of the product. The manufacturer ID for the Atmel AT30TS00 is 001Fh (See Table 6-17).

Table 6-17. Manufacturer ID Register Bit Distribution

Bit	15	14	13	12	11	10	9	8
Symbol	Manufacturer ID							
Default Value	0	0	0	0	0	0	0	0
R / W access	R	R	R	R	R	R	R	R
Bit	7	6	5	4	3	2	1	0
Symbol	Manufacturer ID							
Default Value	0	0	0	1	1	1	1	1
R / W access	R	R	R	R	R	R	R	R

6.9. Device ID Register (16-bit Read only, Address = 07h)

The high order byte is used to specify the device identification and the low byte is used to specify device revision. The device ID for the AT30TS00 is 8201h (See Table 6-18).

Table 6-18. Device ID Register Bit Distribution

Bit	15	14	13	12	11	10	9	8
Symbol	Device ID							
Default Value	1	0	0	0	0	0	1	0
R / W access	R	R	R	R	R	R	R	R
Bit	7	6	5	4	3	2	1	0
Symbol	Device Revision							
Default Value	0	0	0	0	0	0	0	1
R / W access	R	R	R	R	R	R	R	R

6.10. SMBus Register (16-bit Write / Read only, Address = 22h)

The SMBus Register allows the user to enable or disable the SMBus time out feature (See Table 19 and Table 20).

Table 6-19. SMBus Register Bit Distribution

Bit	15	14	13	12	11	10	9	8
Symbol	RFU							
Default Value	0	0	0	0	0	0	0	0
R / W access	R	R	R	R	R	R	R	R
Bit	7	6	5	4	3	2	1	0
Symbol	SMBOUT				RFU			
Default Value	0	0	0	0	0	0	0	0
R / W access	R/W	R	R	R	R	R	R	R

Table 6-20. SMBus Register Bit Distribution

Bit	Symbol	Description
15:8	RFU	Reserved for future use. Read as '0'
7	SMBOUT	SMBus Timeout 0 = SMBus timeout is enabled 1 = SMBus timeout is disabled
6:0	RFU	Reserved for future use. Read as '0'

7. TS Write Operations

Writing to the Atmel® AT30TS00 Temperature register set is accomplished through a modified write operation for two data bytes. To maintain two-wire compatibility, the 16-bit register is accessed through a pointer register, requiring the write sequence to include an address pointer in addition to the device address. This indicates the storage location for the next two bytes received. Figure 7-1 shows an entire write transaction on the bus.

Figure 7-1. TS Register Write Operation

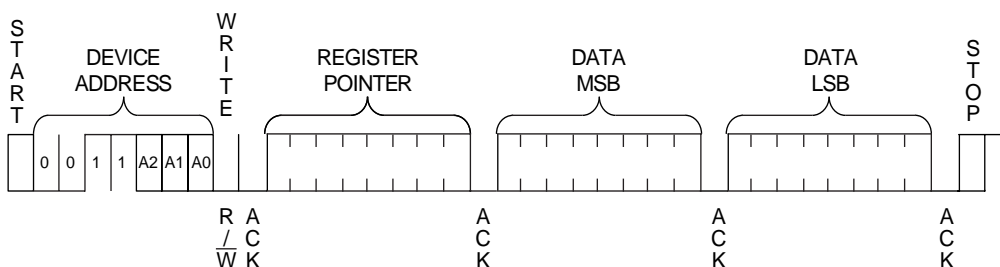

7.2. TS Read Operations

Reading data from the TS may be accomplished in one of two ways:

- If the location latched in the pointer register is correct (for normal operation it is expected the same address will be read repeatedly for temperature), the read sequence may consist of a device address from the bus master followed by two bytes of data from the device; or
- The pointer register is loaded with the correct register address, and the data is read. The sequence to preset the pointer register is shown in Figure 7-2 and the preset pointer read is shown in Figure 7-3. If it is desired to read random address each cycle, the complete Pointer Write, Word Read sequence is shown in Figure 7-4.

The data byte has the most significant bit first. At the end of a read, this device can accept either Acknowledge (Ack) or No Acknowledge (No Ack) from the Master (No Acknowledge is typically used as a signal for the slave that the Master has read its last byte).

Figure 7-2. Write to Pointer Register

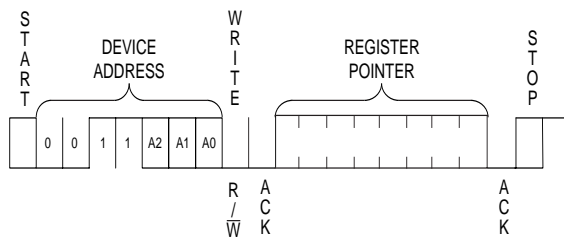

Figure 7-3. Preset Pointer Register Word Read

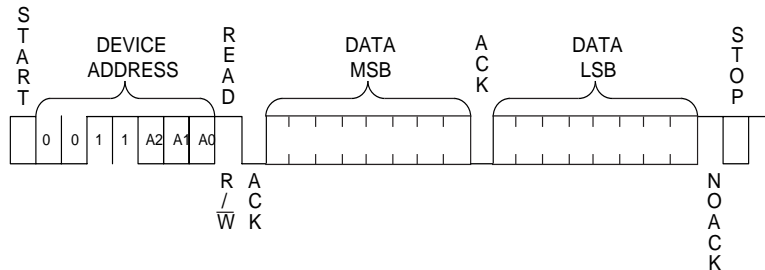
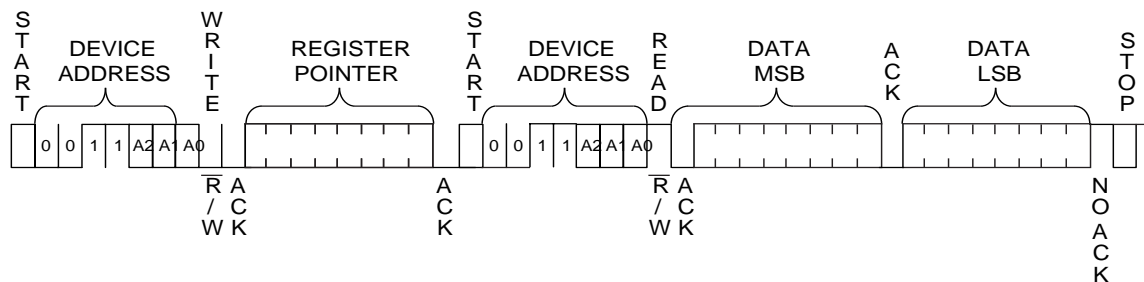

Figure 7-4. Two-Wire Pointer Write Register Word Read





8. Atmel AT30TS00 Ordering Information

Table 8-1. Green Package Options (Pb/Halide-free/RoHS Compliant)

Ordering Code	Package	Lead Finish	Operating Voltage	Max. Freq. (KHz)	Operational range
AT30TS00-MAH-T	8M2	NiPdAu	2.7V to 3.6V	400	-20°C to 125°C

Note: 1. The shipping carrier option code is not marked on the devices

Package Type	
8M2	8-pad, 2 x 3 x 0.8mm, Thermally Enhanced Plastic Very Very Thin Dual Flat No Lead Package (WDFN)



WDFN Marking

TOP MARK

```
|---|---|---|
  T  0
|---|---|---|
  H  2
|---|---|---|
  Y  X  X
|---|---|---|
  *
  |
```

Pin 1 Indicator (Dot)

Y = YEAR OF ASSEMBLY

XX = ATMEL LOT NUMBER TO COORESPOND WITH
TRACE CODE LOG BOOK.

(e.g. XX = AA, AB, AC, ...AX, AY, AZ)

Y = SEAL YEAR

8: 2008	2: 2012
9: 2009	3: 2013
0: 2010	4: 2014
1: 2011	5: 2015

9. Package Drawing

8M2 – WDFN

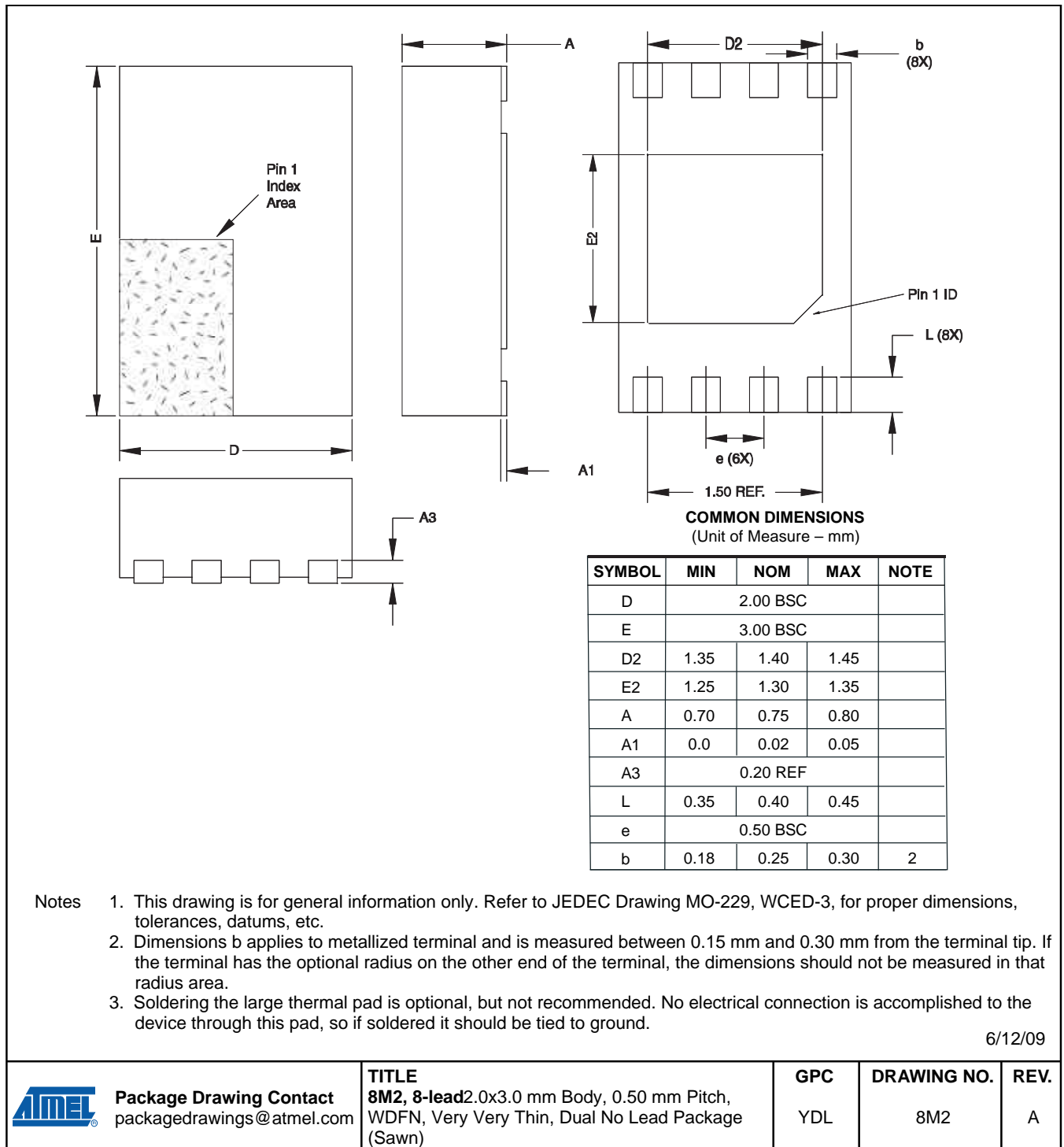

10. Revision History

Doc. Rev.	Date	Comments
8585B	08/2010	Memory Module to Two-wire Add I_{CC} , Timeout active, $V_{CC} = 3.6V$ in DC Parameters Remove t_{AA} , Clock Low to Data Out Valid in AC Parameters Add $T_{HD,DI}$, Data In Hold Time in AC Parameters Change 0 to 1 for 8-bit default value in Device ID Register Bit Distribution Replace Bus Timing figure Change 8200h to 8201h Change AT30TS00-MA-T to AT30TS00-MAH-T
8585A	12/2009	Initial document release



Headquarters

Atmel Corporation

2325 Orchard Parkway
San Jose, CA 95131
USA
Tel: (+1) (408) 441-0311
Fax: (+1) (408) 487-2600
www.atmel.com

International

Atmel Asia Limited

Unit 01-5 & 16, 19F
BEA Tower, Millennium City 5
418 Kwun Tong Road
Kwun Tong, Kowloon
HONG KONG
Tel: (+852) 2245-6100
Fax: (+852) 2722-1369

Atmel Munich GmbH

Business Campus
Parking 4
D-85748 Garching b. Munich
GERMANY
Tel: (+49) 89-31970-0
Fax: (+49) 89-3194621

Atmel Japan

9F, Tonetsu Shinkawa Bldg.
1-24-8 Shinkawa
Chuo-ku, Tokyo 104-0033
JAPAN
Tel: (+81) (3) 3523-3551
Fax: (+81) (3) 3523-7581

Product Contact

Technical Support

s_eeeprom@atmel.com

Sales Contact

www.atmel.com/contacts

Literature Requests

www.atmel.com/literature

Disclaimer: The information in this document is provided in connection with Atmel products. No license, express or implied, by estoppel or otherwise, to any intellectual property right is granted by this document or in connection with the sale of Atmel products. **EXCEPT AS SET FORTH IN ATMEL'S TERMS AND CONDITIONS OF SALE LOCATED ON ATMEL'S WEB SITE, ATMEL ASSUMES NO LIABILITY WHATSOEVER AND DISCLAIMS ANY EXPRESS, IMPLIED OR STATUTORY WARRANTY RELATING TO ITS PRODUCTS INCLUDING, BUT NOT LIMITED TO, THE IMPLIED WARRANTY OF MERCHANTABILITY, FITNESS FOR A PARTICULAR PURPOSE, OR NON-INFRINGEMENT. IN NO EVENT SHALL ATMEL BE LIABLE FOR ANY DIRECT, INDIRECT, CONSEQUENTIAL, PUNITIVE, SPECIAL OR INCIDENTAL DAMAGES (INCLUDING, WITHOUT LIMITATION, DAMAGES FOR LOSS OF PROFITS, BUSINESS INTERRUPTION, OR LOSS OF INFORMATION) ARISING OUT OF THE USE OR INABILITY TO USE THIS DOCUMENT, EVEN IF ATMEL HAS BEEN ADVISED OF THE POSSIBILITY OF SUCH DAMAGES.** Atmel makes no representations or warranties with respect to the accuracy or completeness of the contents of this document and reserves the right to make changes to specifications and product descriptions at any time without notice. Atmel does not make any commitment to update the information contained herein. Unless specifically provided otherwise, Atmel products are not suitable for, and shall not be used in, automotive applications. Atmel's products are not intended, authorized, or warranted for use as components in applications intended to support or sustain life.

© 2010 Atmel Corporation. All rights reserved.

Atmel®, Atmel logo and combinations thereof, and others are registered trademarks, CryptoAuthentication™ and others, are trademarks of Atmel Corporation or its subsidiaries. Other terms and product names may be trademarks of others.