

**Features**

- Optimal for 2 phase excitation drive for 2-phase stepping motors / shutter for DSC
- Built-in 3 operating mode:  
Saturation Output  
Constant Voltage Output  
Constant Current Output
- Low saturation voltage.  $V_{o(sat)} = 0.26\text{ V}$  typical at  $I_o = 210\text{ mA}$  for saturation output mode
- Stand-by current:  $<1\mu\text{A}$
- Independently controlled for CH1 and CH2
- TSSOP20 Package

**Applications**

- Camera
- Printer
- Other portable equipment

**General Description**

The AT5549 is 2-channel low-voltage/low saturation voltage type bidirectional motor driver IC that are optimal for use as 2-phase stepping motor drivers in cameras, printers, and other portable equipment. The output circuits are of the H-bridge bipolar type, and they achieve low saturation output and low power characteristics despite being provided in a miniature package. Operation for each independent CH1(OUT1,2) and CH2(OUT3,4) is selectable from saturation output drive, constant voltage drive and constant current drive according to the circuit conditions.

The AT5549 is optimal for 2-phase excitation drive for 2-phase stepping motors using 4-input logic (ENA1,ENA2, IN1,IN2).

**Block Diagram**

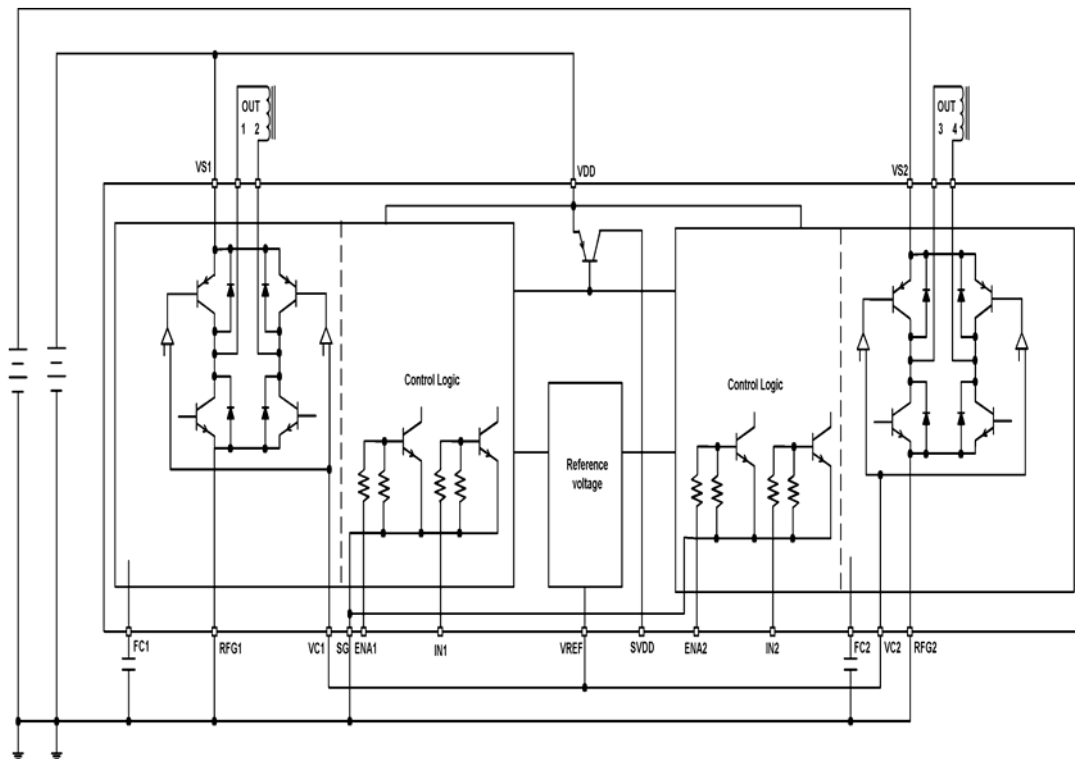

**Aimtron reserves the right without notice to change this circuitry and specifications.**

**Pin Configuration**

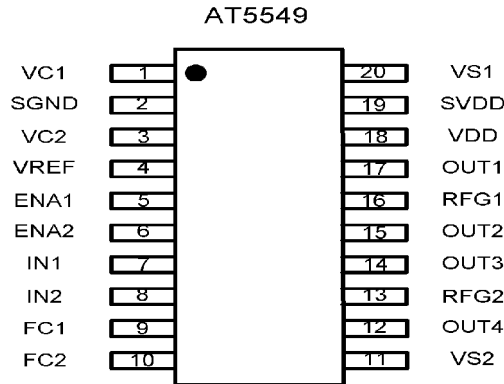

**Ordering Information**

Part number	Package	Marking
AT5549P	TSSOP20	AT5549P
AT5549P GRE	TSSOP20,Green	AT5549P, date code with one bottom line

**Pin Description**

Symbol	Pin No.	Descript	Symbol	Pin No.	Descript
VC1	1	Reference voltage input terminals for CH1 output	VS2	11	Power supply input for CH2 output
SGND	2	- input for drive voltage	OUT4	12	Shutter coil drive terminal
VC2	3	Reference voltage input terminals for CH2 output	RFG2	13	Current Control pin for CH2
VREF	4	0.9V Reference voltage output	OUT3	14	Shutter coil drive terminal
ENA1	5	CH1 Enable input	OUT2	15	Shutter coil drive terminal
ENA2	6	CH2 Enable input	RFG1	16	Current Control pin for CH1
IN1	7	Control terminal for CH1	OUT1	17	Shutter coil drive terminal
IN2	8	Control terminal for CH2	VDD	18	+ input for drive voltage
FC1	9	Connect capacitor between FC1 and SGND to prevent oscillation at constant current mode	SVDD	19	VDD voltage output
FC2	10	Connect capacitor between FC1 and SGND to prevent oscillation at constant current mode	VS1	20	Power supply input for CH1 output

**Absolute Maximum Rating**
 $T_a = +25^\circ\text{C}$ 

Parameter	Symbol	Condition	Ratings	Units
Maximum Supply Voltage	VCC		-0.3 to +8.0	V
OUT1,2,3,4 Voltage	VOUT		-0.3 to +8.0	V
OUT1,2,3,4 output current	IOUT		300	mA
Input Voltage	VIN		-0.3 to VDD +0.4	V
Power Dissipation	PD	Mounted PCB*Note	850	mW
Operating Temperature	Ta		-20 to +75	°C
Storage Temperature	Tstg		-40 to +150	°C

Note: On the 114.3x76.1x1.6-mm glass-epoxy printed circuit board

**Electrical Characteristics**
 $(T_a = +25^\circ\text{C})$ 

Parameter	Symbol	Conditions	Ratings			Unit
			Min.	Typ.	Max.	
Stand-by current	I <sub>STB</sub>	V <sub>E</sub> =6.5V	-	-	1.0	μA
Vref output voltage	V <sub>refOL</sub>	V <sub>DD</sub> =5V, IOL=0	0.85	0.90	0.95	V
S <sub>VDD</sub> output voltage	V <sub>SVDD</sub>	V <sub>DD</sub> =5V, IOL=10mA	4.7	4.8	4.9	V
<b>H Bridge</b>						
Function assurance voltage range 1	V <sub>OPR1</sub>	V <sub>DD</sub> system, V <sub>S1,2</sub> =2.0V	1.9	-	6.5	V
Function assurance voltage range 2	V <sub>OPR2</sub>	V <sub>S</sub> system, V <sub>D</sub> =5.0V	1.6	-	6.5	V
Output saturation voltage 1 (OUT) ( Saturation control)	V <sub>OUT1</sub>	V <sub>DD</sub> =2.9 to 5V, V <sub>C</sub> =SVDD, V <sub>S</sub> =2V I <sub>OL</sub> =210mA (PNP side) , Standard circuit 1	0.07	0.2	0.3	V
Output saturation voltage 2 (OUT) ( Saturation control)	V <sub>OUT2</sub>	V <sub>DD</sub> =2.9 to 5V, V <sub>C</sub> =SVDD, V <sub>S</sub> =2V I <sub>OL</sub> =210mA (NPN side) , Standard circuit 1	0.09	0.13	0.16	V
Output voltage 1 (OUT) ( CV control)	V <sub>OUT3</sub>	V <sub>DD</sub> =2.9 to 6V, V <sub>C</sub> =1.54V, V <sub>S</sub> =3.5V I <sub>OL</sub> =210mA (PNP side) , Standard circuit 2	2.8	3.0	3.2	V
Output voltage 2 (OUT) ( CV control)	V <sub>OUT4</sub>	V <sub>DD</sub> =2.9 to 5V, V <sub>C</sub> =Vref, V <sub>S</sub> =2V I <sub>OL</sub> =210mA (PNP side) , Standard circuit 2	1.66	1.76	1.86	V
Output voltage 1 (OUT) ( CC control)	V <sub>OUT5</sub>	V <sub>DD</sub> =2.9 to 5V, V <sub>C</sub> =1.8V, V <sub>S</sub> =3.5V, R <sub>L</sub> =5Ω (across OUTs) , R <sub>FB</sub> =2Ω , Standard circuit 3	190	212	234	mA
Output voltage 2 (OUT) ( CC control)	V <sub>OUT6</sub>	V <sub>DD</sub> =2.9 to 5V, V <sub>C</sub> = Vref, V <sub>S</sub> =1.95V, R <sub>L</sub> =5Ω (across OUTs) , R <sub>FB</sub> =2Ω , Standard circuit 3	95	112	124	mA

Operating current consumption S1	$I_{OPS1}$	$V_S$ system, $V_{DD}=5V$ , $V_S=3V$ , $V_C=SVDD$	-	20	30	mA
Operating current consumption S2	$I_{OPS2}$	$V_S$ system, $V_{DD}=5V$ , $V_S=3V$ , $V_C=V_{ref}$	-	1	2	mA
Operating current consumption D1	$I_{OPD1}$	$V_{DD}$ system, $V_{DD}=5V$ , $V_S=3V$ , $V_C=SVDD$	-	3.5	6	mA
Operating current consumption D2	$I_{OPD2}$	$V_{DD}$ system, $V_{DD}=5V$ , $V_S=3V$ , $V_C=V_{ref}$	-	3.5	6	mA
Pass through current	$I_{TC}$	$V_{DD}=5V$ , $V_S=3.5V$	-	10	20	mA
Pass through current generating time	$T_{TC}$	$V_{DD}=5V$ , $V_S=3.5V$	-	-	2	$\mu S$
Switching delay time	$T_{TSWI}$		-	-	0.1	$\mu S$
VC input current	$I_{IN}$	$V_{DD}=2.9$ to $6V$ , $V_S=2.0V$ , $V_{C1}=V_{C2}=5.5V$ , $V_{IN}=5.0V$	0	120	150	$\mu A$
<b>Control input</b>						
Maximum input current of control terminals	$I_{IH}$	$V_{DD}=5V$ , $V_S=3.5V$ , $V_{IH}=5.5V$	-	-	100	$\mu A$
	$I_{IL}$	$V_{IL}=GND$	-1	-	0	$\mu A$
Input "L" level	$V_{IL}$	ENA, IN	-0.3	-	1.0	V
Input "H" level	$V_{IH}$	ENA, IN	2.0	-	6.0	V

**Truth Tables**

ENA		IN		SVDD	OUT1	OUT2	OUT3	OUT4	Notes
1	2	1	2						
L	L	×	×	OFF	OFF	OFF	OFF	OFF	Standby mode
H	L	H	×	ON	L	H	OFF	OFF	CH1 reverse rotation
		L	×	ON	H	L	OFF	OFF	CH1 forward rotation
L	H	×	H	ON	OFF	OFF	L	H	CH2 reverse rotation
		×	L	ON	OFF	OFF	H	L	CH2 forward rotation
H	H	H	H	ON	L	H	L	H	CH1,2 reverse rotation
		L	L	ON	H	L	H	L	CH1,2 forward rotation
H	H	H	L	ON	L	H	H	L	CH1 reverse & CH2 forward rotation
		L	H	ON	H	L	L	H	CH1 forward & CH2 reverse rotation

× indicates "don't care"

Constant voltage output VO is controlled as  $VO=1.95 \cdot VC$ .

Input range of VC is 0.2 to 6V and the output is saturation when  $VC \geq VO$

Constant current output IO is controlled as  $IO=(VC/4.5)/RFG$

CH1 (between OUT1 and OUT2\* and CH2 (between OUT3 and OUT4) are controlled independently

**Typical Application**

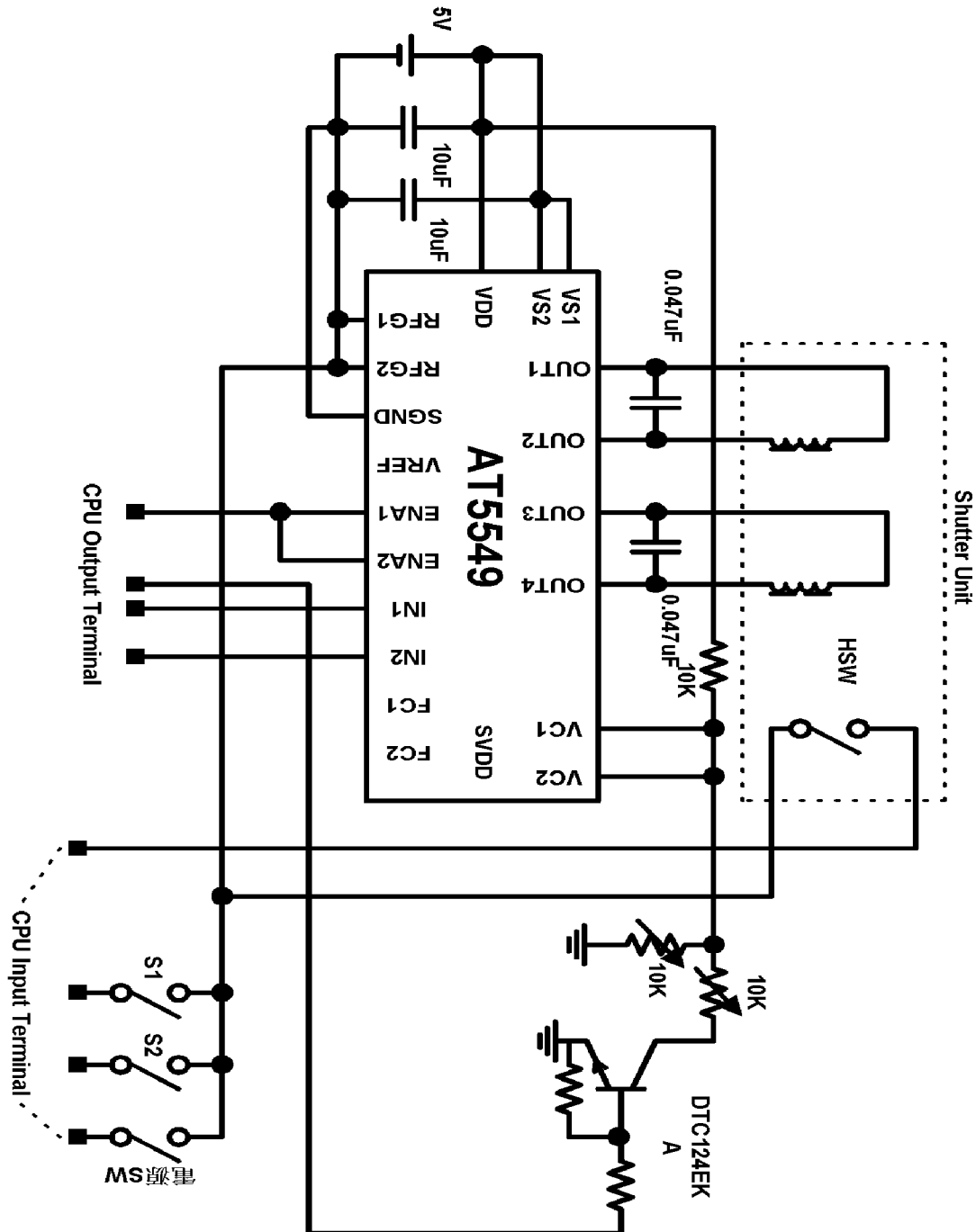

**Application Information**

**(1) Saturation drive control**

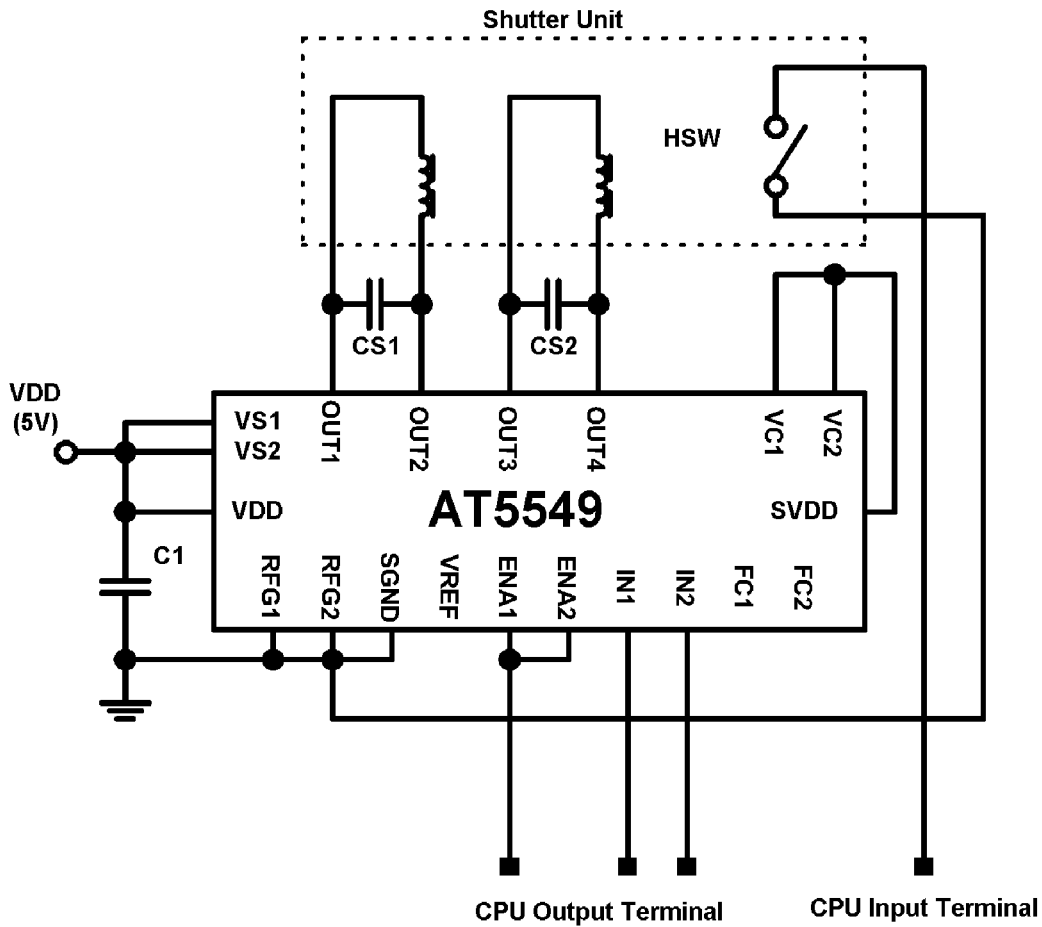

Operational conditions for saturation drive control

- Shorting RFG with SGND
- Connecting a capacitor of 4700pF~0.22uF between OUTs
- Inputting the voltage that is  $VC > VS/1.95V$  ( $VS \geq 1.6V$ )
- Output voltage  $V_{OUT}$

$$V_{OUT} = VS - VSAT(\text{PNP}) - VSAT(\text{NPN}) \quad *VSAT = \text{saturation voltage}$$

(2) Constant voltage drive control

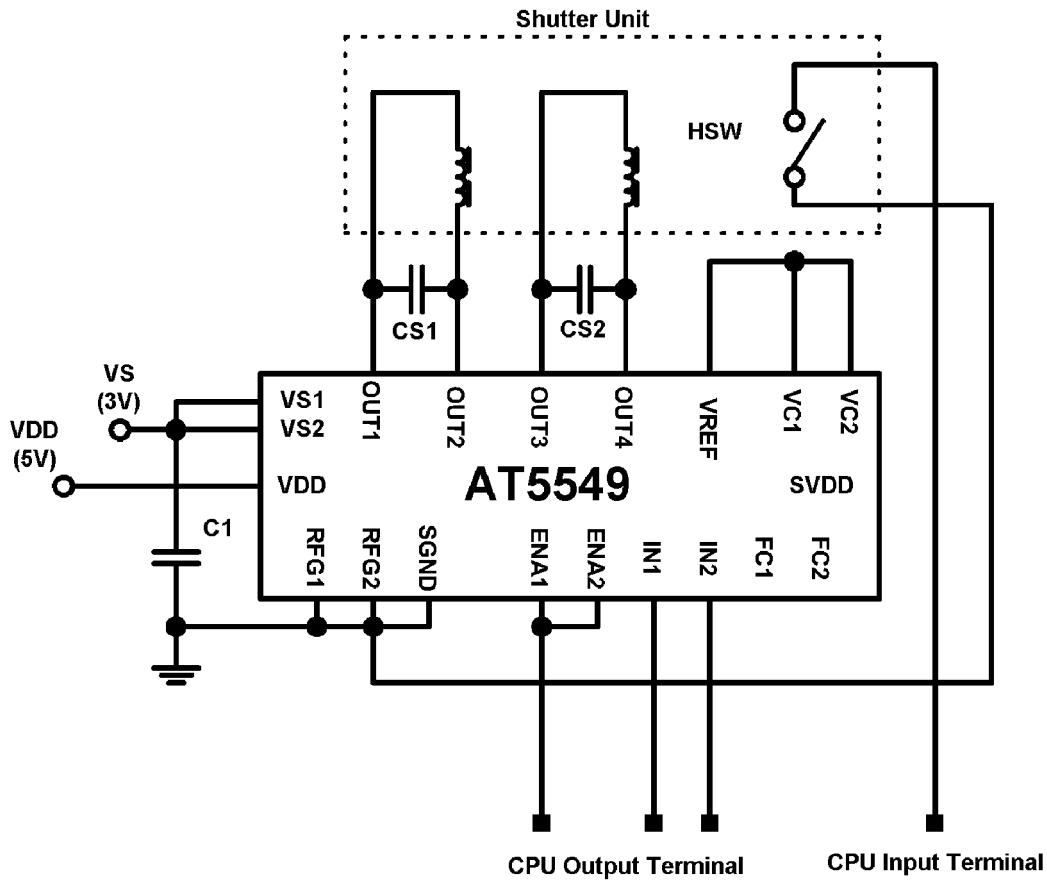

Operational conditions for constant voltage drive control

- Shorting RFG with SGND
- Connecting a capacitor of 4700pF~0.22uF between OUTs
- Inputting the voltage that is  $VS \geq VC \times 1.95V$  ( $VS \geq 1.6V$ )
- Output voltage VOUT

**$V_{OUT} = 1.95 \times V_C - V_{SAT(NPN)}$  \* $V_{SAT}$ =saturation voltage**

(3) Constant current drive control

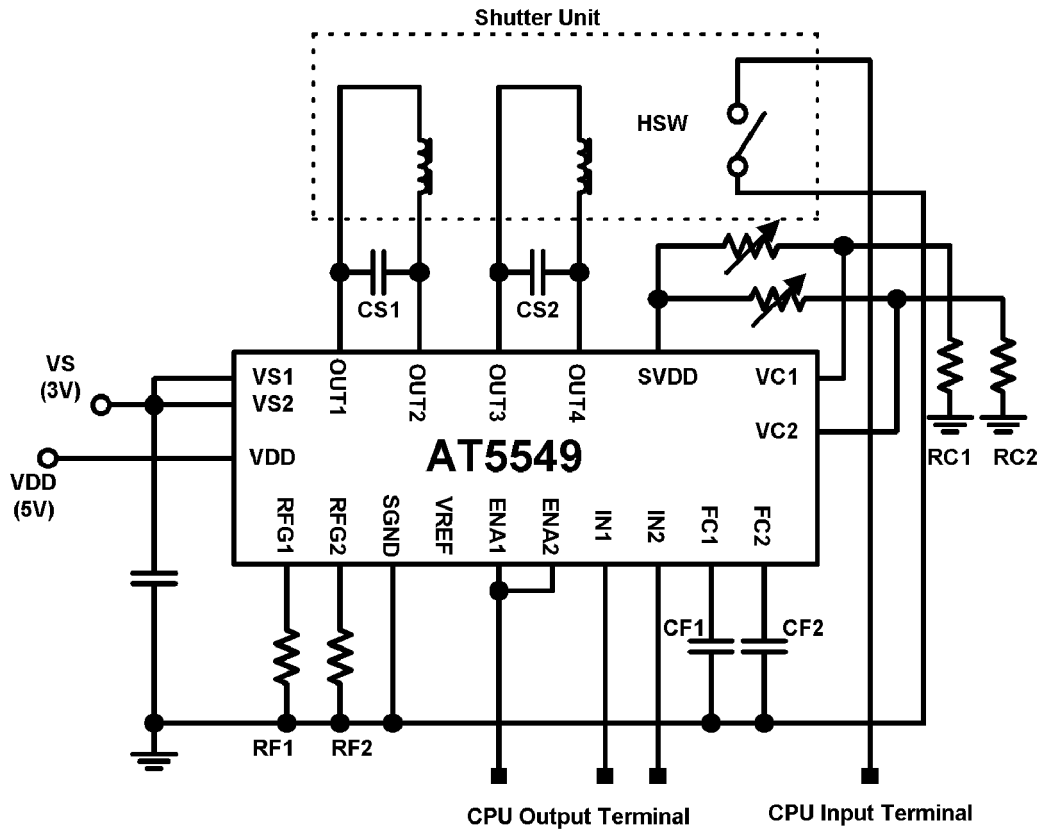

Operational conditions for constant current drive control

- Connecting RF between RFG and SGND
- Connecting a capacitor of 680pF between FC and SGND to prevent oscillation
- Connecting a capacitor of 4700pF~0.22uF between OUTs
- Can be shorting VS with VDD(Single power)
- Output current  $I_{OUT}$

$$I_{OUT} = \frac{V_C}{R_F \times 4.5} (A)$$

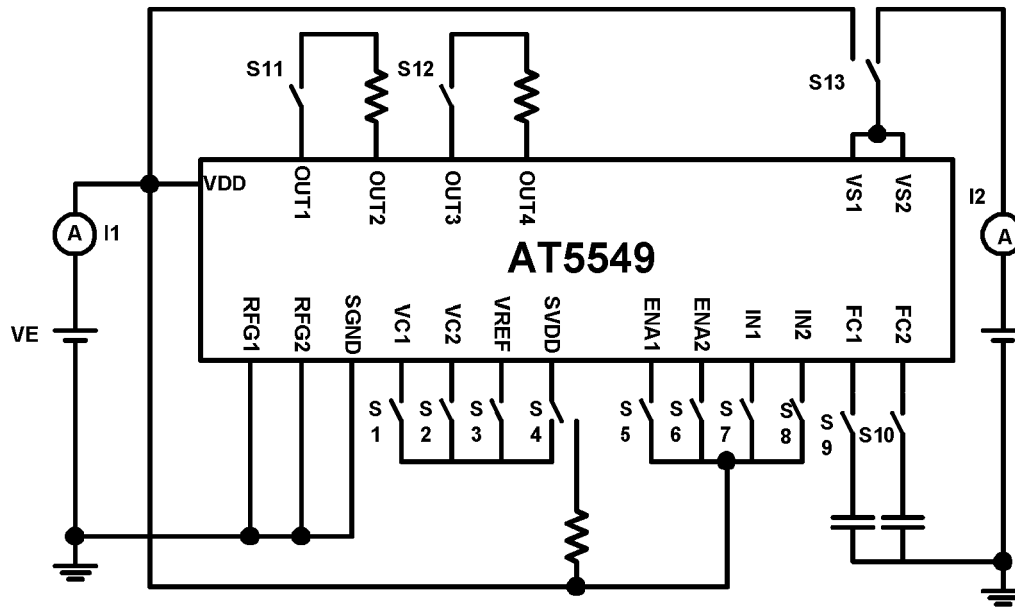

**Test Circuit**

**Switch conditions table**

Circuit Part	VC1	VC2	VREF	SVDD	ENA1	ENA2	IN1	IN2	OUT	VS	Current to be measure
SW	1	2	3	4	5	6	7	8	11~12	13	
Standby	ON	ON	ON	GND	OFF	OFF	OFF	OFF	ON	VDD	I1
Stepping motor	ON	ON	ON	VC	ON	OFF	×	×	OFF	VS	I1
	ON	ON	OFF	OFF	ON	OFF	×	×	OFF	VS	I1
	ON	ON	VC	VC	ON	OFF	×	×	OFF	VS	I2
	ON	ON	OFF	OFF	ON	OFF	×	×	OFF	VS	I2

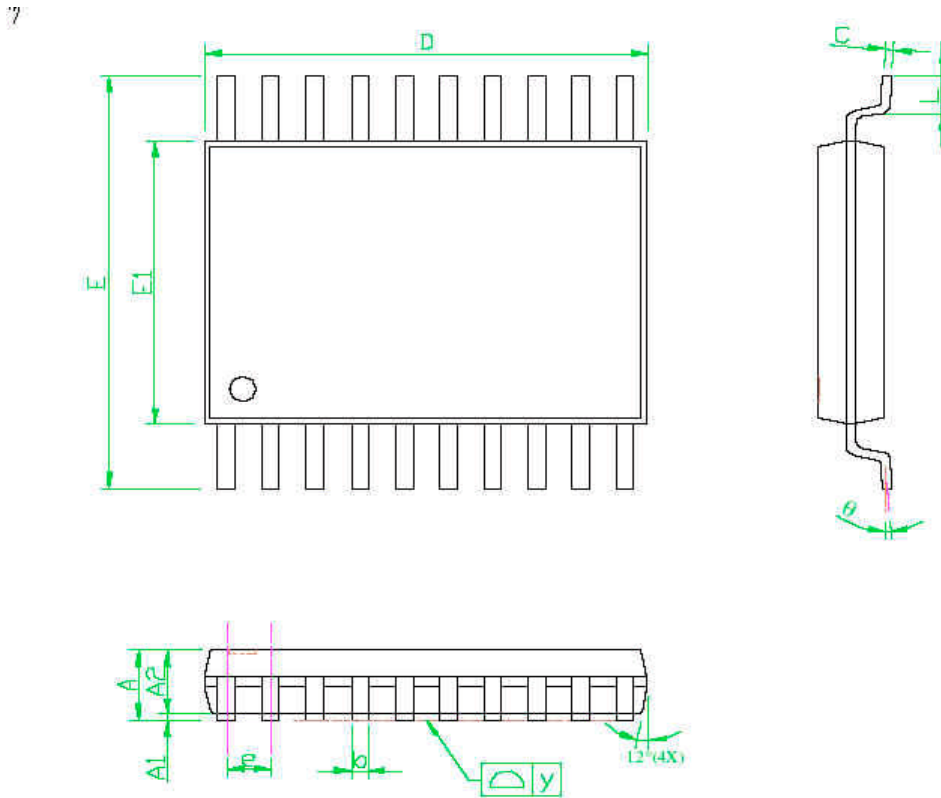
**Package Outline: TSSOP20**



SYMBOLS	DIMENSIONS IN MILLIMETERS			DIMENSIONS IN INCHES		
	MIN	NOM	MAX	MIN	NOM	MAX
A	—	—	1.20	—	—	0.048
A1	0.05	—	0.15	0.002	—	0.006
A2	0.80	1.00	1.05	0.031	0.039	0.041
b	0.19	—	0.30	0.007	—	0.012
C	0.09	—	0.20	0.004	—	0.008
D	6.40	6.50	6.60	0.252	0.256	0.260
E	6.20	6.40	6.60	0.244	0.252	0.260
E1	4.30	4.40	4.50	0.169	0.173	0.177
e	—	0.65	—	—	0.026	—
L	0.45	0.60	0.75	0.018	0.024	0.030
y	—	—	0.10	—	—	0.004
θ	0°	—	8°	0°	—	8°