



圓創科技股份有限公司

AT5669

**5-Channel Motor Driver for DVD/VCD
with 2 Linear Regulator and 1 OPAMP**

Features

- 4 channels of DC motor BTL driver
- 1 channels forward/reverse control DC motor driver
- Built-in suspension function.
- Built-in 2 Linear Regulator
- Built-in 1-Channel operational amplifier.
- Built-in thermal shutdown circuit.
- Operating voltage: 4.5V~13.2V

Description

The AT5669 is a 5-channel BTL driver IC. Two of them can drive DC motors and two can drive coils, such as the focus and tracking actuators of a CD-ROM/DVD-ROM/DVD-Player system. It also built-in one channel bi-direction DC motor driver for Tray. Using the built-in linear regulator, it can save the PCB space. It also includes 1 operational amplifier.

Applications

CD-ROM/DVD-ROM/CD-RW drives
DVD player.

Block Diagram

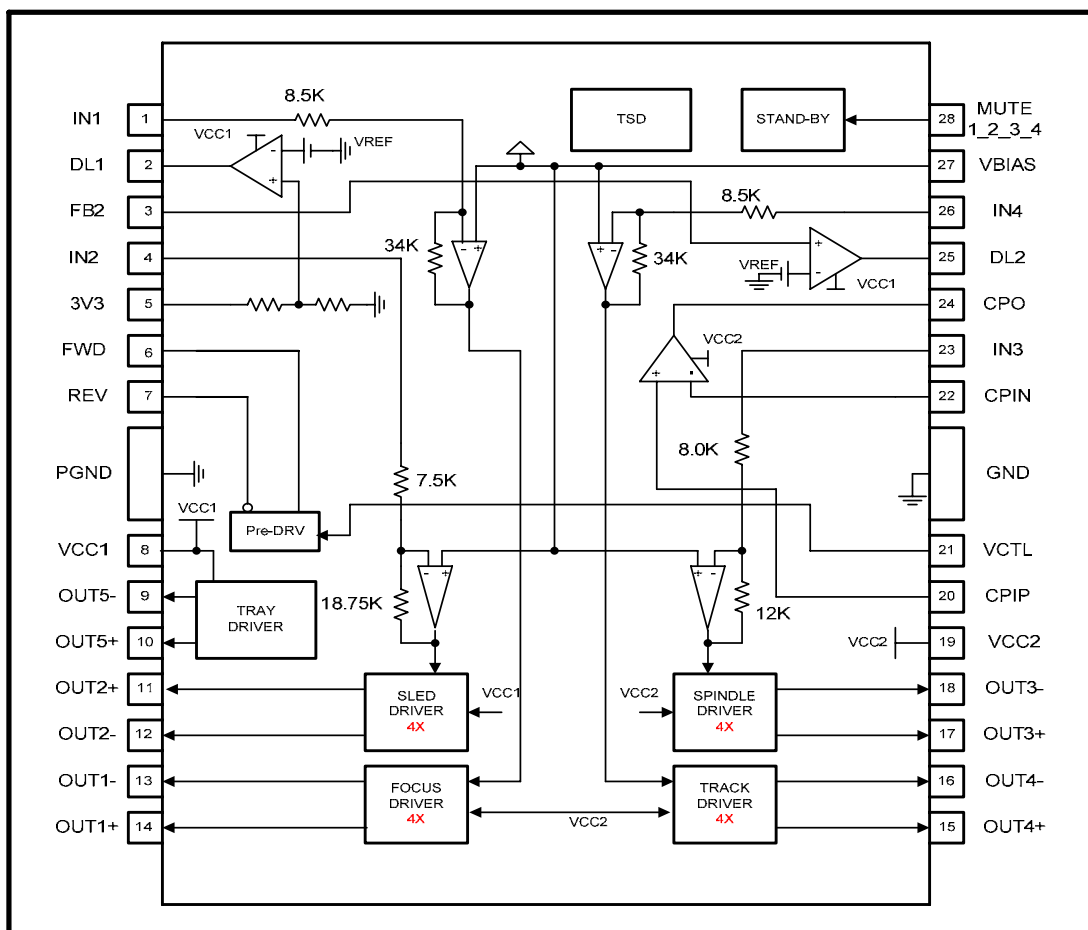

Aimtron reserves the right without notice to change this circuitry and specifications.

Pin Descriptions

Pin No.	Pin name	Function
1	IN1	CH1(Focus coil) input
2	DL1	Linear Regulator 3V3 driver output
3	FB2	Linear Regulator 2 feedback input
4	IN2	CH2(Sled driver) input
5	3V3	Linear Regulator 3V3 input
6	FWD	CH5 forward input
7	REV	CH5 reverse input
8	VCC1	Power Supply 1
9	OUT5-	CH5(Tray driver) output(-)
10	OUT5+	CH5(Tray driver) output(+)
11	OUT2+	CH2(Sled driver) output (+)
12	OUT2-	CH2(Sled driver) output (-)
13	OUT1-	CH1(Focus coil) output (-)
14	OUT1+	CH1(Focus coil) output (+)
15	OUT4+	CH4(Tracking coil) output (+)
16	OUT4-	CH4(Tracking coil) output (-)
17	OUT3+	CH3(Spindle) output (+)
18	OUT3-	CH3(Spindle) output (-)
19	VCC2	Power Supply 2
20	CPIP	OP positive input
21	VCTL	CH5 Speed control input
22	CPIN	OP negative input
23	IN3	CH3(Spindle) input
24	CPO	OP Output
25	DL2	Adjustable Linear Regulator driver output
26	IN4	CH4 (Tracking driver) input
27	VBIAS	VREF input pin
28	MUTE_1_2_3_4	Mute control for CH1,CH2,CH3,CH4

Notes: The indicated polarities for the output pins are under the condition that all inputs are (+).
The power supplies for the driver output are Vcc1 for the loader, Vcc2 for focus and tracking drivers, and Vcc for pre-block and sled driver. Therefore, make sure $V_{cc1} \geq V_{cc2}$.

Pin Out

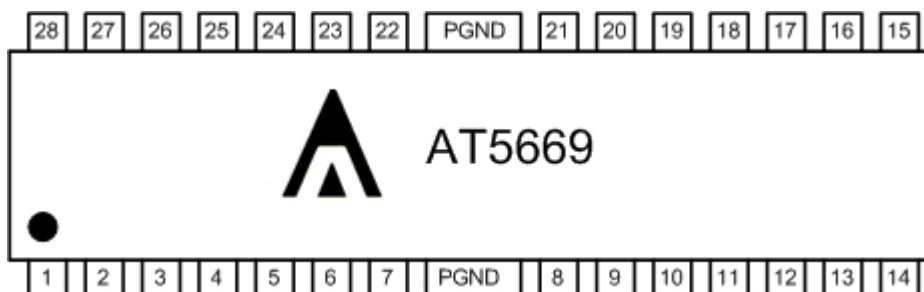

Ordering Information

Part number	Package	Marking
AT5669H	28-pin HSOP	AT5669H
AT5669H_PBF	28-pin HSOP, PB-Free	AT5669H, Date Code with one bottom line

Power Dissipation (Ta = 25°C)

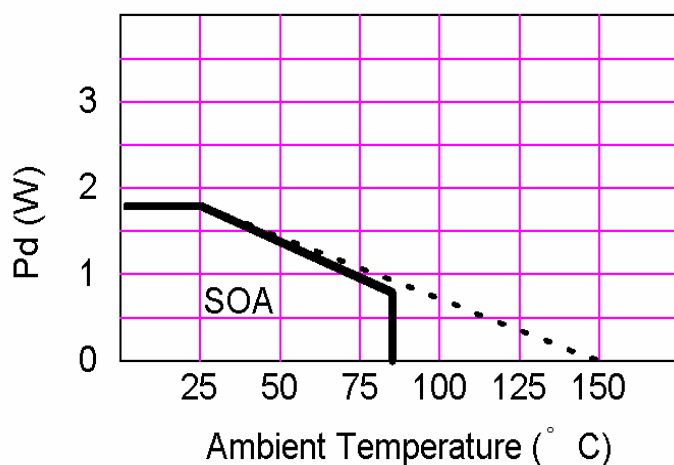

Condition: mount on 50x50 mm² t=1.0mm paper phenol PCB

Absolute maximum ratings (Ta = 25°C)

Parameter	Symbol	Limits	unit
Power supply voltage	VCC1,2	13.5	V
Power dissipation	P _d	1.7	W
Operating temperature	T _{opr}	-30~+80	°C
Storage temperature	T _{stg}	-55~+150	°C

NOTE:*

1. Power dissipation reduces 13.6mW / °C for using above Ta=25°C
2. Do not exceed Pd and SOA.

Recommended operating conditions (Ta = 25°C)

Parameter	Symbol	Limits	unit
Power supply voltage	VCC1	4.0~13.2	V
	VCC2	4.0~Vcc1	V

Electrical characteristics

(unless otherwise noted, $T_a = 25^\circ\text{C}$, $V_{CC1} = 5\text{V}$, $V_{CC2} = 5\text{V}$, $V_{BIAS} = 2.5\text{V}$, $R_{L1} = R_{L4} = 10\Omega$, $R_{L2} = 10\Omega$, $R_{L3} = 10\Omega$)

Parameter	Symbol	Min.	Typ.	Max.	Unit	Conditions
Quiescent current	I_{QC}	-	20	35	mA	No Load, FWD=REV=Low
Mute quiescent current	I_{QSB}	-	-	8	mA	CH5 ,COMP. Active LD1,LD2 floating
Bias input current	I_{Bias}	-	-	1	μA	
Mute ON voltage	V_{SBON}	0	-	0.5	V	
Mute OFF voltage	V_{SBOFF}	1.2	-	-	V	
<Track driver>						
Output voltage offset	V_{OFFSL}	-100	0	100	mV	
Maximum output voltage	V_{O4MAX}	3.6	4.0	-	V	$V_{IN} = V_{BIAS} \pm 1.5\text{V}$
Closed loop gain	G_{VSL}	-	24.0	-	dB	$V_{IN} = V_{BIAS} \pm 0.2\text{V}$
<Focus driver>						
Output voltage offset	V_{OFFSL}	-100	0	100	mV	
Maximum output voltage	V_{O1MAX}	3.6	4.0	-	V	$V_{IN} = V_{BIAS} \pm 1.5\text{V}$
Closed loop gain	G_{VSL}	-	24.0	-	dB	$V_{IN} = V_{BIAS} \pm 0.2\text{V}$
<Sled motor driver>						
Output voltage offset	V_{OFFSL}	-100	0	100	mV	
Maximum output voltage	V_{O2max2}	3.6	4.0	-	V	$V_{IN} = V_{BIAS} \pm 1.5\text{V}$
Closed loop gain	G_{VSL}	18.0	20.0	22.0	dB	$V_{IN} = V_{BIAS} \pm 0.2\text{V}$
<Spindle motor driver>						
Output voltage offset	V_{OFFLD}	-100	0	100	mV	
Maximum output voltage	V_{O3max2}	3.6	4.0	-	V	$V_{IN} = V_{BIAS} \pm 1.5\text{V}$
Closed loop gain	G_{VLD}	13.5	15.5	17.5	dB	$V_{IN} = V_{BIAS} \pm 0.2\text{V}$
Gain error	ΔG_{VLD}	0	1	2	dB	$V_{IN} = V_{BIAS} \pm 0.2\text{V}$
<Tray motor driver>						
Maximum output voltage	V_{O5max1}	-	3.95	-	V	$R_{L5} = 30\Omega$, $R_{VCTL} = 0\Omega$,
		-	4.05	-	V	$R_{L5} = 45\Omega$, $R_{VCTL} = 0\Omega$,
Output voltage offset	V_{OFFTR}	-100	0	100	mV	
Input high level voltage	V_{IH}	1.2	-	-	V	
Input low level voltage	V_{IL}	-	-	0.5	V	
High level input current	I_{IH}	-	25	50	μA	FWD=REV=2.5V
<Comparator>						
Input Offset	V_{Offset}	-	-	± 15	mV	
Input Dynamic Range		0	-	$V_{CC1} - 1.5\text{V}$	V	
Output Dynamic Range	V_{OH}	-	-	$V_{CC1} - 1.0\text{V}$	V	$I_O = -1\text{mA}$

	V _{OL}	0.25	-	0.40	V	I _O =4mA
Voltage Gain	A _v	-	80	-	dB	DC
<Linear Regulator 1>						
3V3 Threshold Voltage	V _{T1}	3.234	3.300	3.366	V	
3V3 Input Bias Current	I _{T1}	1.0	-	3.0	mA	3V3=3.3V
Output sink current of DL1	I _{DL1}	10	-	30	mA	
<Linear Regulator 2>						
FB2 Threshold Voltage	V _{T2}	1.225	1.25	1.275	V	
FB2 Input Bias Current	I _{T2}	-	-	1	μA	FB2=1.8V
Output sink current of DL2	I _{DL2}	10	-	30	mA	

Tray Motor Driver

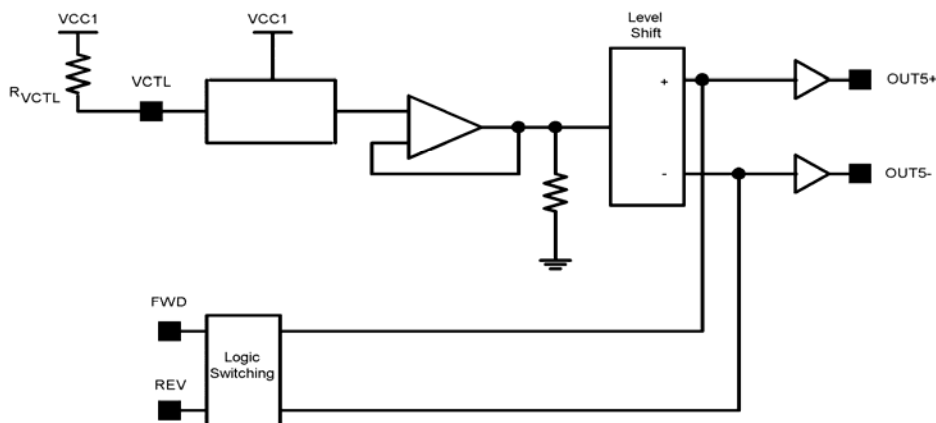

Fig1.

Input		Output		
FWD	REV	OUT5+	OUT5-	Status
High	High	Low	Low	Break
High	Low	High	Low	Forward
Low	High	Low	High	Reverse
Low	Low	Open	Open	Standby

Tray Motor Speed Control

The amplitude of the output voltage is controlled by VCTL(pin21). If you want to control differential output voltage of the tray, insert external resistor R_{VCTL} as shown in figure 1.

Test Circuit

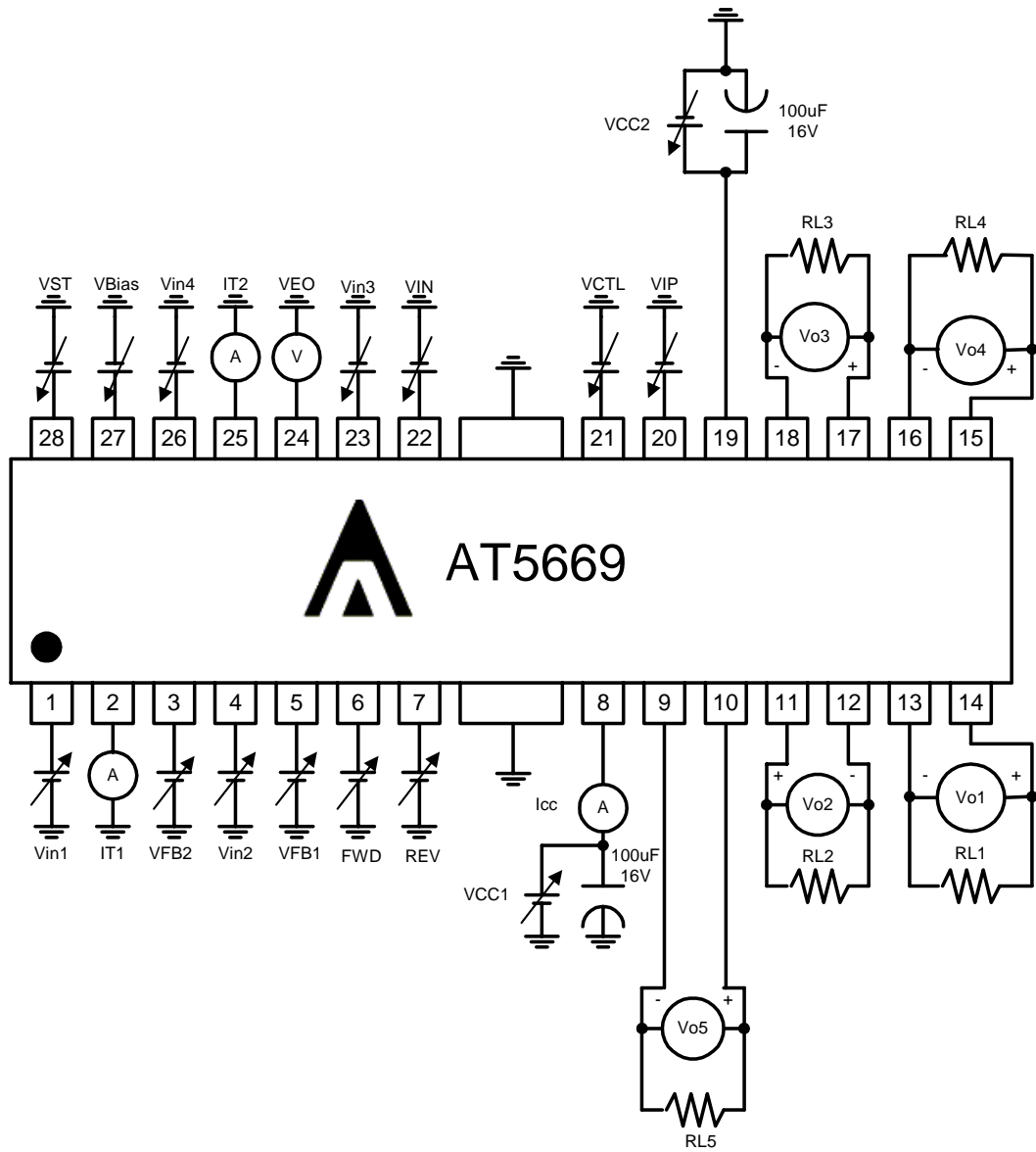

Typical Curve

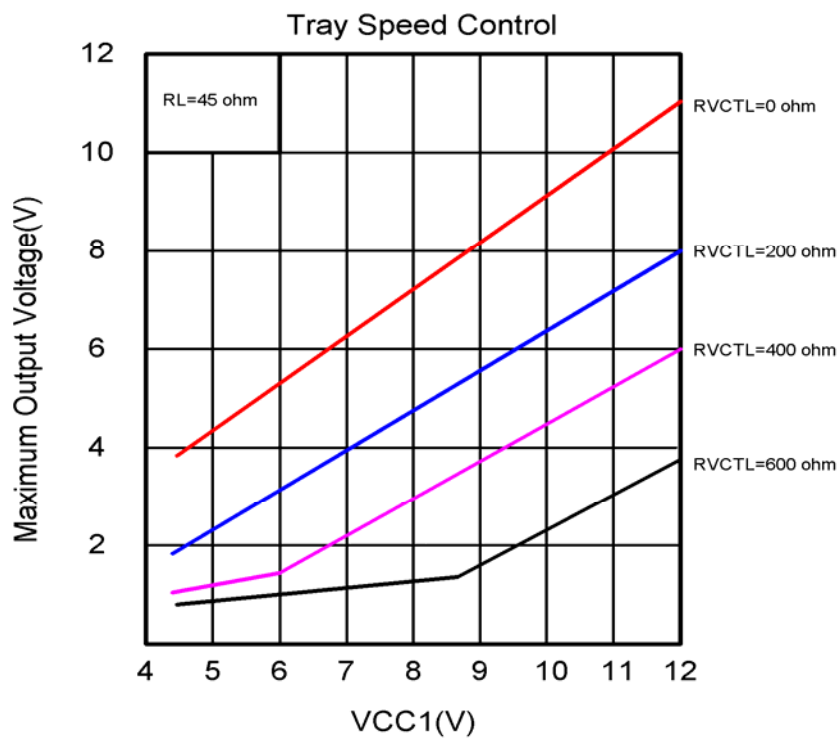
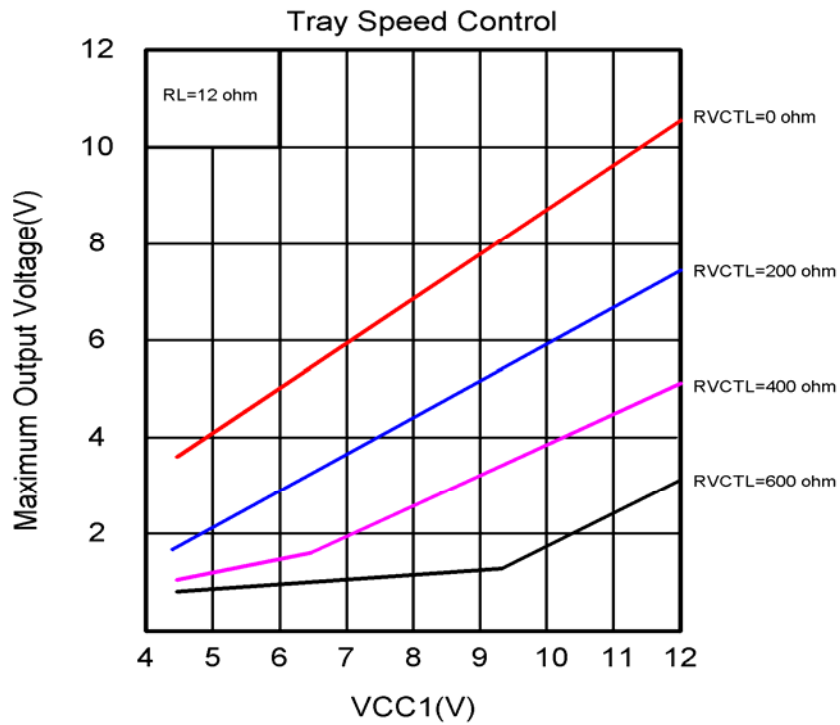

Application circuit

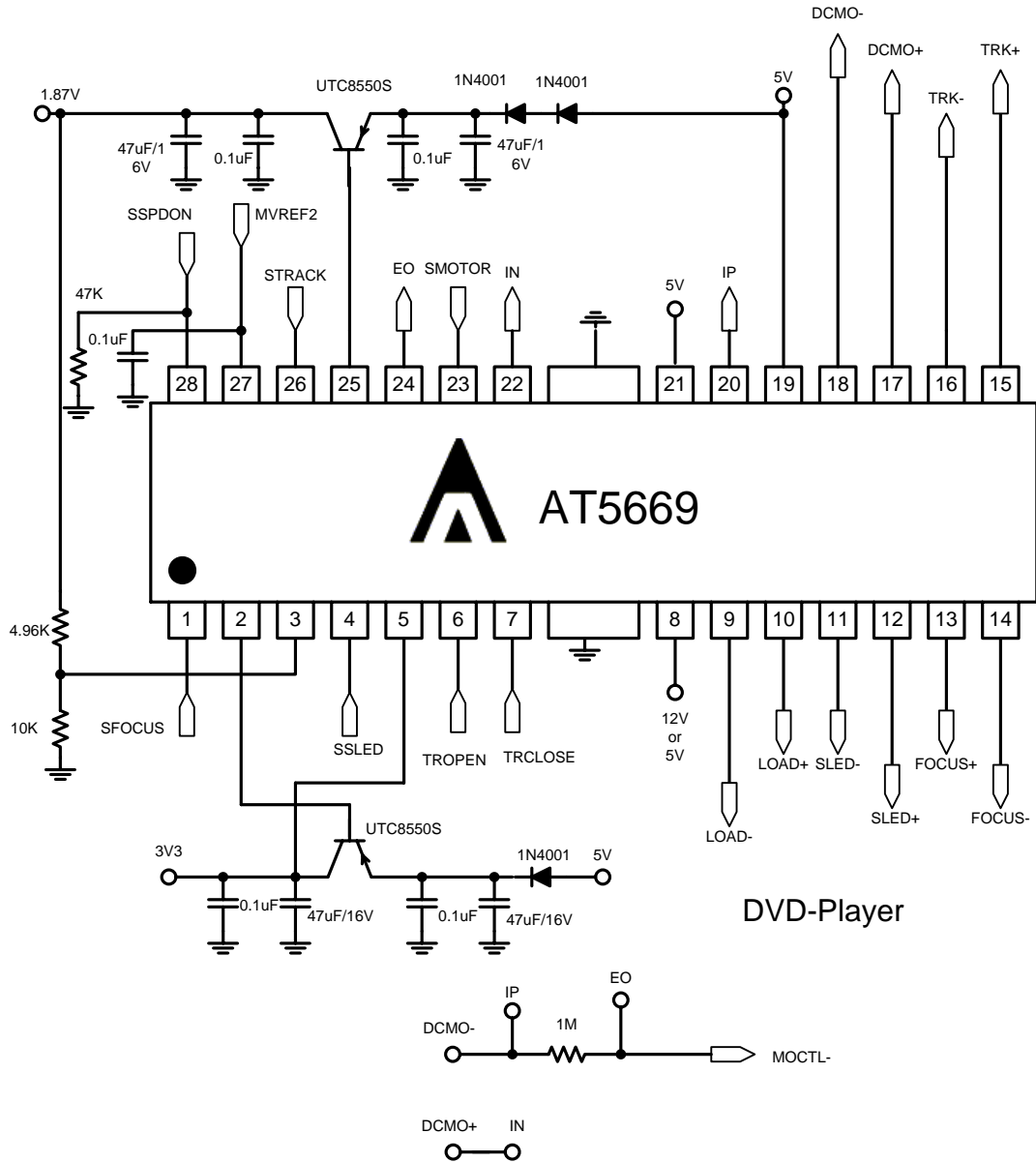

Package Outlines (units:mm): HSOP-28

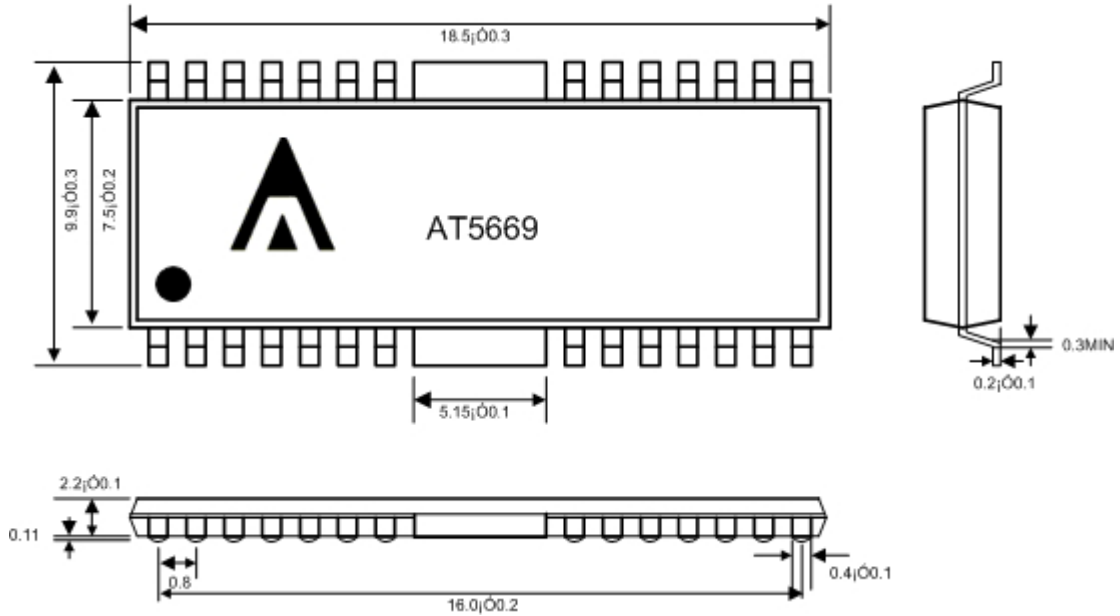

Reflow Profiles

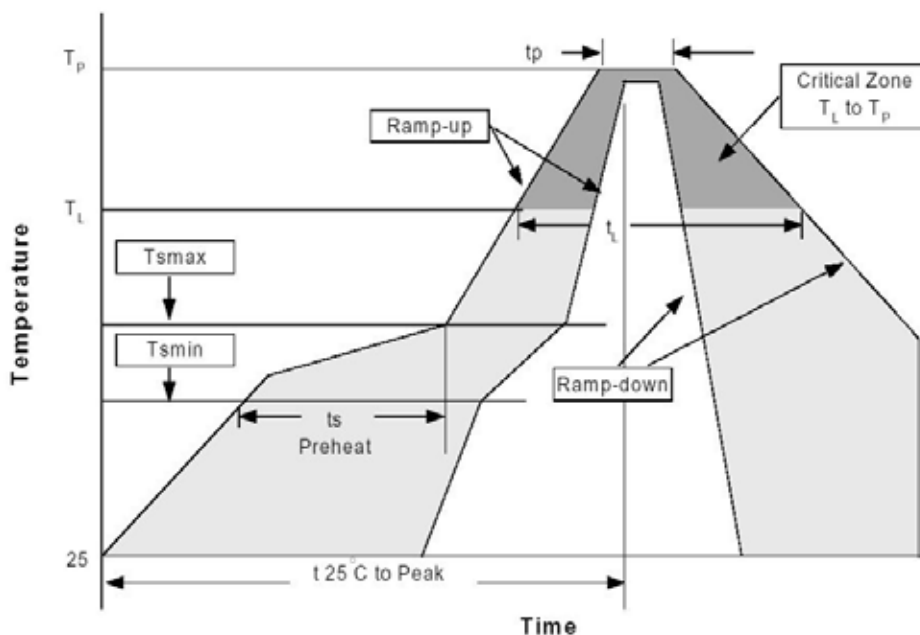

Profile Feature	Sn-Pb Eutectic Assembly		Pb-Free Assembly	
	Large Body Pkg. thickness ≥2.5mm or Pkg. volume ≥350mm ³	Small Body Pkg. thickness <2.5mm or Pkg. volume <350mm ³	Large Body Pkg. thickness ≥2.5mm or Pkg. volume ≥350mm ³	Small Body Pkg. thickness ≥2.5mm or Pkg. volume ≥350mm ³
Average ramp-up rate (T _L to T _P)	3°C/second max.		3°C/second max.	
Preheat -Temperature Min(T _{min}) -Temperature Max (T _{max}) -Time (min to max)(t _s)	100°C 150°C 60-120 seconds		150°C 200°C 60-180 seconds	
T _{max} to T _L -Ramp-up Rate			3°C/second max.	
Time maintained above: -Temperature (T _L) -Time (t _L)	183°C 60-150 seconds		217°C 60-150 seconds	
Peak Temperature(T _P)	225+0/-5°C	240+0/-5°C	245+0/-5°C	250+0/-5°C
Time within 5°C of actual Peak Temperature (t _p)	10-30 seconds	10-30 seconds	10-30 seconds	20-40 seconds
Ramp-down Rate	6°C/second max.		3°C/second max.	
Time 25°C to Peak Temperature	6 minutes max.		8 minutes max.	

*All temperatures refer to topside of the package, measured on the package body surface.