

Features

- 4 channels of H-bridge drivers.
- Built-in DC/DC converter control circuit.
- Built-in reset circuit.
- Built-in reduced voltage detection circuit.
- Built-in battery charging circuit.
- Built-in general purpose operation amplifier.
- Built-in thermal shutdown circuit.
- Low power consumption.
- QFP44 package.

Description

The AT5801 is a 4-channel driver and power controller that includes the reset, battery charge and reduced voltage detection circuits required for portable CD players on a single chip. The driver block power supply uses the on-chip switching regulator, making this component an ideal choice for low-power sets.

Applications

- Portable compact disk players (CDP)
- Portable Mini disk player (MD)
- Disk-man
- Other portable compact disk media

Block Diagram

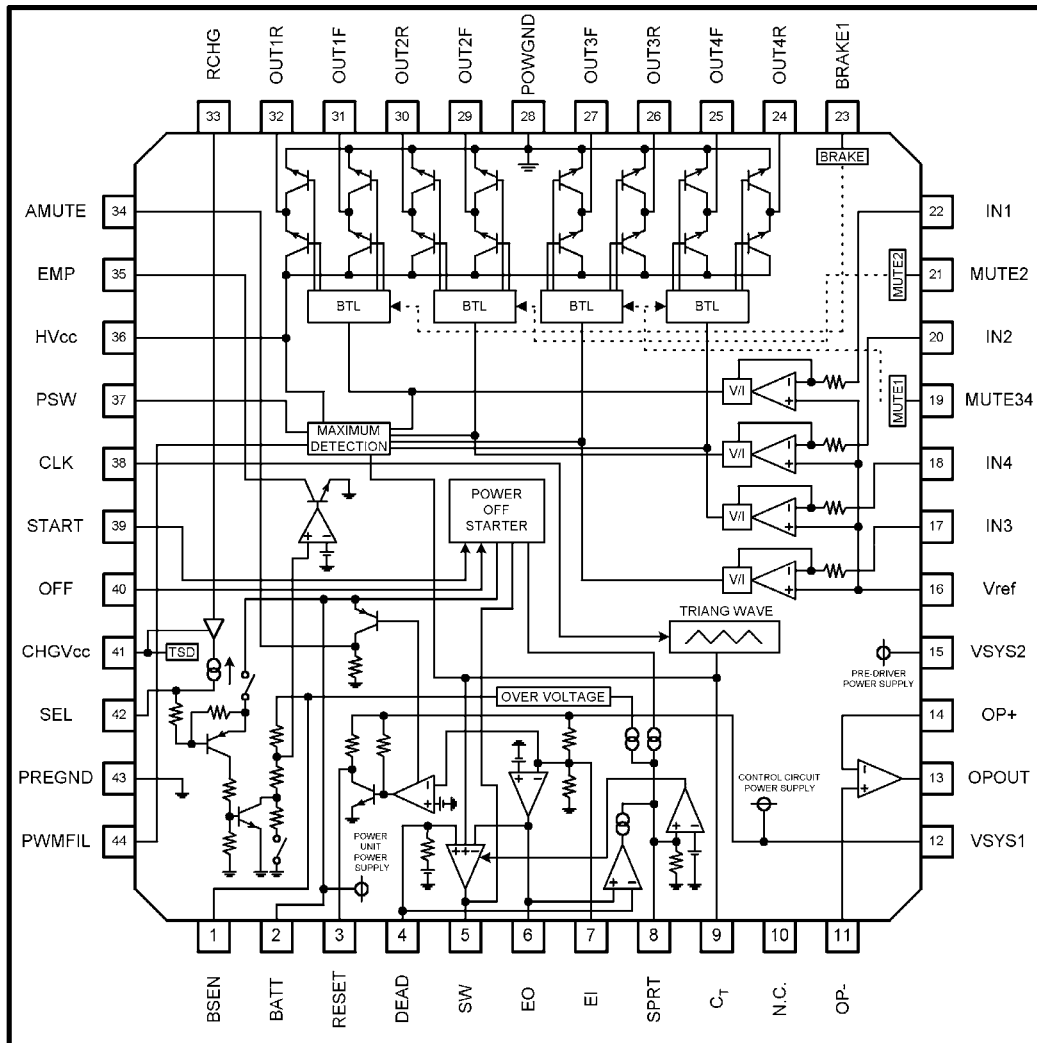

Pin Descriptions

Pin No.	Pin name	Function
1	BSEN	Battery voltage monitor
2	BATTY	Battery power supply input
3	RESET	Reset detection output
4	DEAD	Dead-time setting
5	SW	Booster transistor drive
6	EO	Error amplifier output
7	EI	Error amplifier input
8	SPRT	Short-circuit protection setting
9	CT	Triangular wave output
10	N.C.	
11	Op-	Operational amplifier negative input
12	VSYS1	Control circuit power supply input
13	OPOUT	Operational amplifier output
14	Op+	Operational amplifier positive input
15	VSYS2	Pre-driver power supply input
16	VREF	Reference power supply input
17	IN3	CH3 control signal input
18	IN4	CH4 control signal input
19	MUTE34	CH3/CH4 mute
20	IN2	CH2 control signal input
21	MUTE2	CH2 mute
22	IN1	CH1 control signal input
23	BRAKE1	CH1 brake
24	OUT4R	CH4 negative output
25	OUT4F	CH4 positive output
26	OUT3R	CH3 negative output
27	OUT3F	CH3 positive output
28	POWGND	Power block power supply ground
29	OUT2F	CH2 positive output
30	OUT2R	CH2 negative output
31	OUT1F	CH1 positive output
32	OUT1R	CH1 negative output
33	RCHG	Charging current setting
34	AMUTE	Reset inversion output
35	EMP	“Empty” detection output
36	HVCC	H-bridge power supply input
37	PSW	PWM transistor drive
38	CLK	External clock synchronization input
39	START	Boost DC/DC converter starting
40	OFF	Boost DC/DC converter OFF
41	CHGVCC	Charging circuit power supply input
42	SEL	“Empty” detection level switching
43	PREGND	Pre section power supply ground
44	PWMFIL	PWM phase compensation

Pin Assignments

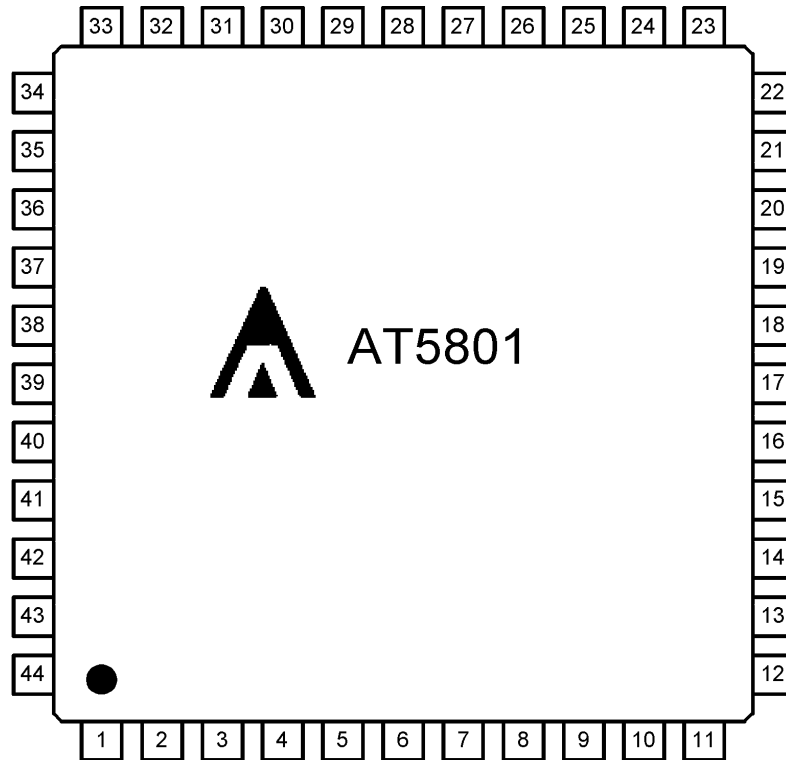

Absolute maximum ratings (Ta = 25°C)

Parameter	Symbol	Limits	unit
Supply voltage	V _{CC}	13.5	V
Driver output current	I _o	500	mA
Power dissipation	P _d	625*	mW
Operating temperature range	T _{opr}	0~+80	°C
Storage temperature range	T _{stg}	-55~+150	°C

* Derating is done 5mW/°C for operation above Ta=25°C.

Recommended operating conditions (Ta = 25°C)

Parameter	Symbol	Min.	Typ.	Max.	unit
Control circuit power supply voltage	VSYS1	2.7	3.2	5.5	V
Pre-driver power supply voltage	VSYS2	2.7	3.2	5.5	V
H-bridge power supply voltage	HVCC	-	PWM	BATT	V
Power unit power supply voltage	BATT	1.5	2.4	8.0	V
Charging circuit power supply voltage	CHGVCC	3.0	4.5	8.0	V
Ambient temperature	Ta	0	25	70	°C

Electrical characteristics

(Unless specified particular, Ta = 25°C, BATT=2.4V, VSYS1= VSYS2=3.2V, VREF=1.6V, CHGVCC=0V, CLK=88.2KHz)

Parameter	Symbol	Min.	Typ.	Max.	Unit	Conditions
Total circuit						
BATT stand-by current	I _{ST}	—	0	3	μA	BATT=9V VSYS1=VSYS2=Vref=0V
BATT supply current at no-load	I _{BAT}	—	2.5	4.0	mA	HVcc=0.45V, MUTE34=3.2V
VSYS1 supply current at no-load	I _{SY1}	—	4.7	6.4	mA	HVcc=0.45 MUTE34=3.2V, EI=0V
VSYS2 supply current at no-load	I _{SY2}	—	4.1	5.5	mA	HVcc=0.45V, MUTE34=3.2V
CHGVCC supply current at no-load	I _{CGVCC}	—	0.65	2.0	mA	CHGVcc=4.5V, ROUT=OPEN
H-bridge driver section						
Voltage gain (CH1、3、4) (CH2)	G _{VCI34}	12	14	16	dB	
	G _{Vc2}	21.5	23.5	24.5	dB	
Gain error by polarity	ΔG _{Vc}	-2	0	2	dB	
IN pin (CH1、3、4)	R _{IN134}	9	11	13	kΩ	IN=1.7 and 1.8V
Input resistance (CH2)	R _{IN2}	6	7.5	9	kΩ	
Maximum output voltage	V _{OUT}	1.9	2.1	—	V	RL=8Ω、HVCC=BATT=4V、 IN=0—3.2V
Lower transistor saturated voltage	V _{SATL}	—	240	400	mV	I _o =-300mA、IN=0 and 3.2V
Upper transistor saturated voltage	V _{SATU}	—	240	400	mV	I _o =300mA、IN=0 and 3.2V

Input offset voltage	V_{OI}	-8	0	8	mV	
Output (CH1、3、4) offset voltage (CH2)	V_{OO134}	-50	0	50	mV	$V_{ref}=IN=1.6V$
	V_{OO2}	-130	0	130	mV	
Dead zone	V_{DB}	-10	0	10	mV	
BRAKE1 ON threshold voltage	V_{BRON}	2.0	-	-	V	$IN1=1.8V$
BRAKE1 OFF threshold voltage	V_{BROFF}	-	-	0.8	V	$IN1=1.8V$
MUTE2 ON threshold voltage	V_{M2ON}	2.0	-	-	V	$IN2=1.8V$
MUTE2 OFF threshold voltage	V_{M2OFF}	-	-	0.8	V	$IN2=1.8V$
MUTE34 ON threshold voltage	V_{M34ON}	-	-	0.8	V	$IN3=IN4=1.8V$
MUTE2 OFF threshold voltage	V_{M34OFF}	2.0	-	-	V	$IN3=IN4=1.8V$
VREF ON threshold voltage	V_{refON}	1.2	-	-	V	$IN1=IN2=IN3=IN4=1.8V$
VREF OFF threshold voltage	V_{refOFF}	-	-	0.8	V	$IN1=IN2=IN3=IN4=1.8V$
BRAKE1 brake current	I_{BRAKE1}	4	7	10	mA	BRAKE1 pin The current Difference between "H" and "L"
PWM power supply driving section						
PSW sink current	I_{PSW}	10	13	17	mA	$IN1=2.1V$
HVCC level shift voltage	V_{SHIF}	0.35	0.45	0.55	V	$IN1=1.8V, HVCC=OUT1F$
HVCC leak current	I_{HLK}	-	0	5	μA	$HVCC=9V$ $VSYS1=VSYS2=BATT=0V$
PWM amplifier transfer gain	G_{PWM}	1/60	1/50	1/40	1/k Ω	$IN1=1.8V, HVCC=1.2\sim 1.4V$
DC/DC converter section						
(Error amplifier section)						
VSYS1 pin threshold voltage	V_{SITH}	3.05	3.20	3.35	V	
EO pin output voltage H	V_{EOH}	1.4	1.6	-	V	$EI=0.7V, I_O=-100\mu A$
EO pin output voltage L	V_{EOL}	-	-	0.3	V	$EI=1.3V, I_O=100\mu A$
(Short-circuit protection)						
SPRT pin voltage(normal)	V_{SPR}	-	0	0.1	V	$EI=1.3V$
SPRT pin current 1 EO=H	I_{SPR1}	6	10	16	μA	$EI=0.7V$
SPRT pin current 2 EO=L	I_{SPR2}	12	20	32	μA	$EI=1.3V, OFF=0V$
SPRT pin current 3 (over-voltage)	I_{SPR3}	12	20	32	μA	$EI=1.3V, BATT=9.5V$
SPRT pin impedance	R_{SPR}	175	220	265	k Ω	
SPRT pin threshold voltage	V_{SPTH}	1.10	1.20	1.30	V	$EI=0.7V, CT=0V$
Over-voltage protection detect	V_{HVPR}	8.0	8.4	9.0	V	BSEN pin voltage
(Transistor driving section)						
SW pin output voltage 1H	V_{SW1H}	0.78	0.98	1.13	V	$BATT=C_T=1.5V, I_O=-2mA,$ $VSYS1=VSYS2=0V, at start$

SW pin output voltage 2H	V_{SW2H}	1.0	1.50	—	V	$C_T=0V, I_O=-10mA,$ $EI=0.7V, SPRT=0V$
SW pin output voltage 2L	V_{SW2L}	—	0.3	0.45	V	$C_T=2V, I_O=10mA,$
SW pin oscillating frequency 1	f_{SW1}	80	100	150	KHz	$C_T=470pF,$ $VSYS1=VSYS2=0V, \text{at start}$
SW pin oscillating frequency 2	f_{SW2}	60	70	82	KHz	$C_T=470pF, CLK=0V$
SW pin oscillating frequency 3	f_{SW3}	—	88.2	—	KHz	$C_T=470pF$
SW pin minimum pulse width	T_{SWMIN}	0.01	—	0.6	μsec	$C_T=470pF, EO=0.5\sim 0.7V$ sweep
Pulse duty at start	D_{SW1}	40	50	60	%	$C_T=470pF, VSYS1=VSYS2=0V$
Max. pulse duty at self-running	D_{SW2}	70	80	90	%	$EI=0.7V, C_T=470pF, CLK=0V$
Max. pulse duty at CLK synchronization	D_{SW3}	65	75	85	%	$EI=0.7V, C_T=470pF$
(Dead time section)						
DEAD pin impedance	R_{DEAD}	52	65	78	$k\Omega$	
DEAD pin output voltage	V_{DEAD}	0.78	0.88	0.98	V	
(Interface section)						
OFF pin threshold voltage	V_{OFFTH}	—	—	$VSYS1-2.0$	V	$EI=1.3V$
OFF pin bias current	I_{OFF}	75	95	115	MA	$OFF=0V$
START pin ON threshold voltage	V_{STATH1}	—	—	$BATT-1.0$	V	$VSYS1=VSYS2=0V, C_T=2V$
START pin OFF threshold voltage	V_{STATH2}	$BATT-0.3$	—	—	V	$VSYS1=VSYS2=0V, C_T=2V$
START pin bias current	I_{START}	13	16	19	μA	$START=0V$
CLK pin threshold voltage H	V_{CLKTHH}	2.0	—	—	V	
CLK pin threshold voltage L	V_{CLKTHL}	—	—	0.8	V	
CLK pin bias current	I_{CLK}	—	—	10	μA	$CLK=3.2V$
(Starter circuit section)						
Starter switching voltage	V_{STMM}	2.3	2.5	2.7	V	$VSYS1=VSYS2=0V\sim 3.2V,$ $START=0V$
Starter switching hysteresis width	V_{SNHS}	130	200	300	mV	$START=0V$
Discharge release voltage	V_{DIS}	1.63	1.83	2.03	V	
(Empty detection section)						
Empty detection voltage 1	V_{EMPT1}	2.1	2.2	2.3	V	$VSEL=0V$
Empty detection voltage 2	V_{EMPT2}	1.7	1.8	1.9	V	$ISEL=-2\mu A$
Empty detection hysteresis width 1	V_{EMHS1}	25	50	100	mV	$VSEL=0V$
Empty detection hysteresis width 2	V_{EMHS2}	25	50	100	mV	$ISEL=-2\mu A$
EMP pin output voltage	V_{EMP}	—	—	0.5	V	$I_O=1mA, BSEN=1V$
EMP pin output leak current	I_{EMPL}	—	—	1.0	μA	$BSEN=2.4V$

BSEN pin input resistance	R_{BSEN}	17	23	27	$k\Omega$	$V_{SEL}=0V$
BSEN pin leak current	I_{BSNL}	—	—	1.0	μA	$V_{SYS1}=V_{SYS2}=0V$, $BSEN=4.5V$
SEL pin detection voltage	V_{SELTH}	1.5	—	—	V	$V_{SELTH}=BATT-SEL$, $BSEN=2V$
SEL pin detection current	I_{SELT}	—2	—	—	μA	
(Reset circuit)						
VSYS1 reset threshold voltage ratio	H_{SRT}	85	90	95	%	Ratio of VSYS1 voltage and error-amp threshold voltage
Reset detection hysteresis width	V_{RSTHS}	25	50	100	mV	
RESET pin output voltage	V_{RST}	—	—	0.5	V	$I_o=1mA$, $V_{SYS1}=V_{SYS2}=2.8V$
RESET pin pull up resistance	R_{RST}	72	90	108	$k\Omega$	
AMUTE pin output voltage 1	V_{AMT1}	BATT —0.4	—	BATT	V	$I_o=-1mA$, $V_{SYS1}=V_{SYS2}=2.8V$
AMUTE pin output voltage 2	V_{AMT2}	BATT —0.4	—	BATT	V	$I_o=-1mA$, $START=0V$ $V_{SYS1}=V_{SYS2}=2.8V$
AMUTE pin pull down resistance	R_{AMT}	77	95	113	$k\Omega$	
(Operational amplifier section)						
Input bias current	I_{BIAS}	—	—	300	nA	$OP+=1.6V$
Input offset voltage	V_{OIOF}	—5.5	0	5.5	mV	
High level output voltage	V_{OHOP}	2.8	—	—	V	$RL=OPEN$
Low level output voltage	V_{OLOP}	—	—	0.2	V	$RL=OPEN$
Output drive current (source)	I_{SOU}	—	—6.5	—3.0	mA	Output short to GND by 50Ω
Output drive current (sink)	I_{SIN}	0.4	0.7	—	mA	Output short to VSYS by 50Ω
Open loop voltage gain	GVO	—	70	—	dB	$V_{IN}=-75dBV$, $f=1kHz$
Slew rate	SR	—	0.5	—	$V/\mu s$	
(Charging circuit section)						
RCHG pin bias voltage	V_{RCHG}	0.71	0.81	0.91	V	$CHGV_{CC}=4.5V$, $RCHG=1.8k\Omega$
RCHG pin output resistance	R_{RCHG}	0.75	0.95	1.20	$k\Omega$	$CHGV_{CC}=4.5V$, $RCHG=0.5$ and $0.6V$
SEL pin leak current 1	I_{SELLK}	—	—	1.0	μA	$CHGV_{CC}=4.5V$, $RCHG=OPEN$
SEL pin leak current 2	I_{SELLK}	—	—	1.0	μA	$CHGV_{CC}=0.6V$, $RCHG=1.8k\Omega$
SEL saturation voltage	V_{SELCG}	—	0.45	1.0	V	$CHGV_{CC}=4.5V$, $I_o=200mA$, $RCHG=0\Omega$

*This product is not designed for protection against radioactive rays.

Application

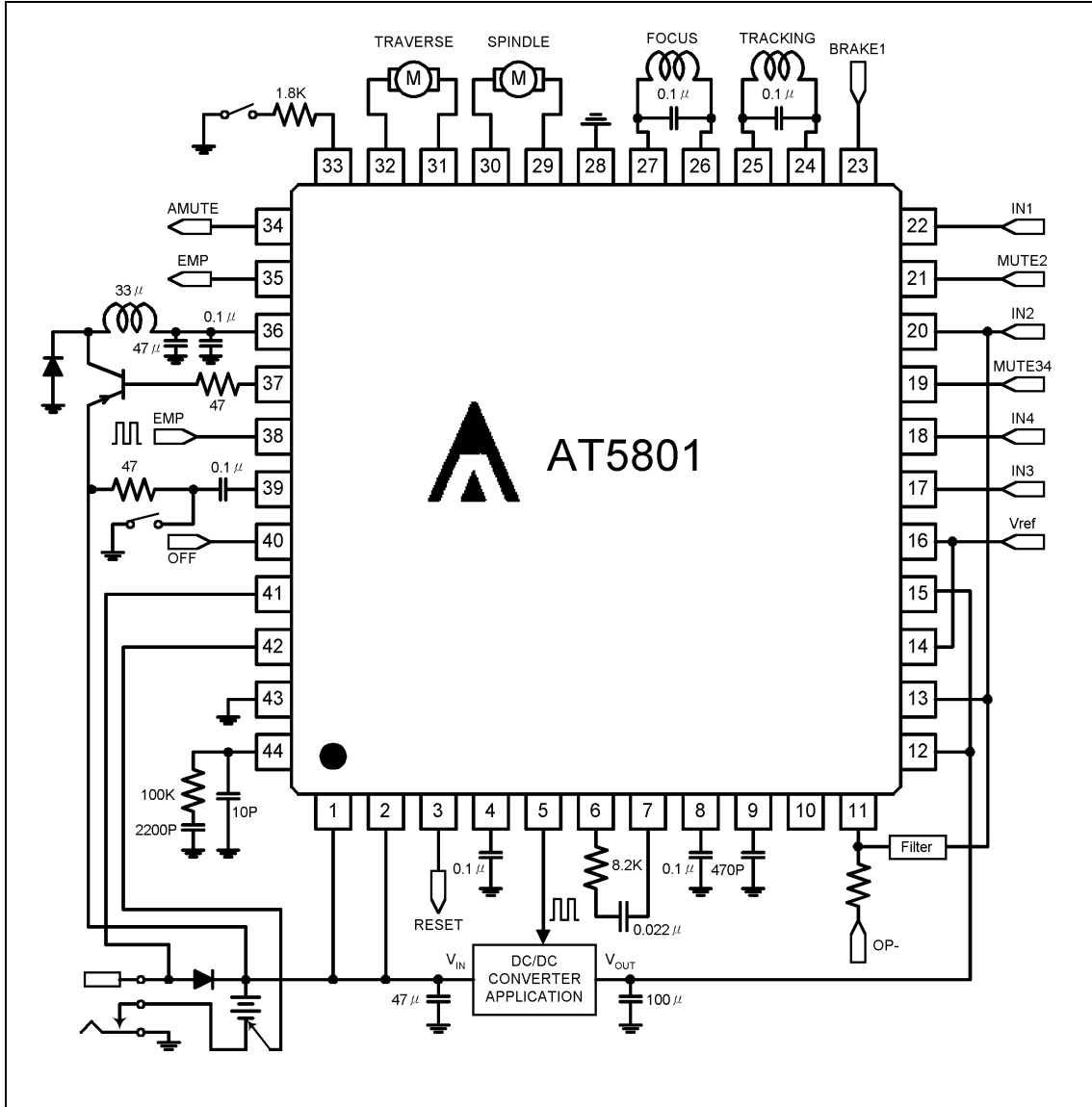

Application explanation

〈H-bridge driver〉

1.Mute function

Brake function and mute function are assigned to CH1 and other channels of the four channels respectively.

- When the BRAKE pin is low is normal operation (high is CH1 mute on),and enters a brake mode.
- When the MUTE2 pin is low is normal operation (high is CH2 mute on).
- When the MUTE34 pin is high is normal operation (low is CH3,4 mute on).

2.VREF drop mute

When the voltage impressed to VREF terminal is 1.0V (typ.) or less, impedance of driver output becomes “high”.

3.Thermal shutdown

If the chip temperature rises above 150 °C,then the thermal shutdown (TSD) circuit is activated and the output current is cut. When the chip temperature has dropped to 120 °C,then output current begins to flow.

4.Driver gain

Driver input resistance is 10k Ω of CH1, CH3,CH4 and input resistance of CH2 is 7.5k Ω .Driver gain can obtain under-mentioned expression and set it.

$$\begin{aligned} \text{CH1,3,4} \quad G_v &= 20 \log \left| \frac{55k}{11k+R} \right| \\ \text{CH2} \quad G_v &= 20 \log \left| \frac{110k}{7.5k+R} \right| \\ R &\text{ is External resistance} \end{aligned}$$

The power supply of drive output stage is HVcc terminal and that of pre-drive circuit is VSYS2 terminal. Attach by-pass capacitor (approximately 0.1 μ F) to the leg of this IC between the power supplies.

〈DC/DC converter control circuit〉

1.Output voltage

Booster circuit of voltage (VSYS1) can be configured with external component. The voltage is defined as follows.

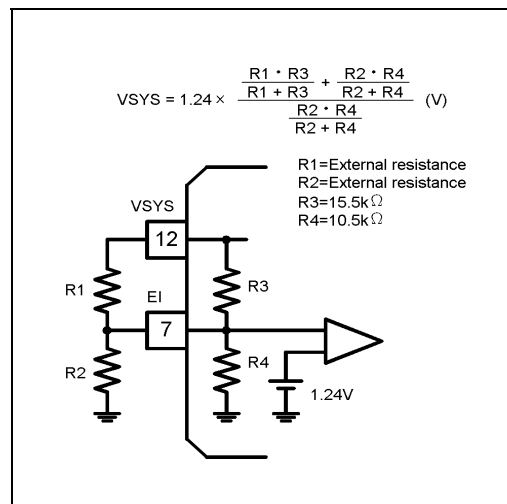

2.Short-circuit protection function

When the output of error amplifier is “H”, if the voltage of SPRT terminal has reached 1.2V(typ.) upon charging the terminal, switching of SW terminal is disabled. Time to disable switching depends on a capacitor of the SPRT terminal and it can be calculated by the under-mentioned expression:

$$t = CSPRT \times \frac{VTH}{ISPRT} \text{ (sec)}$$

($VTH = 1.20V$, $ISPRT = 10\mu A$)

3.Soft-start function

The soft-start is functioned by putting a capacitor between DEAD terminal and GND. Max duty can be changed by attaching resistance to 4-pin.

$$t = CDEAD \times R \text{ (sec)}$$

($R = 65K\Omega$)

4.Power-off operation

SPRT terminal is charged by setting OFF terminal to “L”. Then, switching of SW terminal is terminated when the voltage of the SPRT terminal has reached 1.2V(typ.). Time to disable switching depends on a capacitor of the SPRT terminal and it can be calculated by the under-mentioned expression:

$$t = CSPRT \times \frac{VTH}{IOFF} \text{ (sec)}$$

($VTH = 1.20V$, $IOFF = 20\mu A$)

5.Over-voltage protection operation

When the voltage impressed to BSEN terminal

has been 8.4V(typ.), SPRT terminal is charged. Then, switching of SW terminal is terminated when the voltage of the SPRT terminal has reached 1.2V(typ.). Time to disable switching depends on a capacitor of the SPRT terminal and it can be calculated by the under-mentioned expression:

$$t = CSPRT \times \frac{VTH}{IHW} \text{ (sec)}$$

($VTH = 1.20V$, $IHW = 20\mu A$)

〈 PWM power supply drive circuit 〉

This circuit detects a maximum output level of drivers of four channels and performs the PWM supply of load drive power supply. This circuit uses PNP transistor, Schottky Diode and Capacitor as external component.

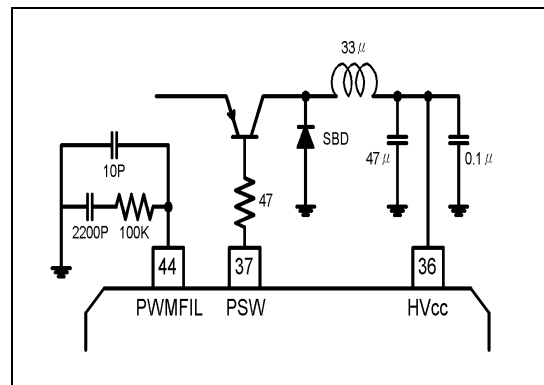

〈 “Empty” detector unit 〉

When the voltage impressed to BSEN terminal has been the detecting voltage or less, EMP terminal varies from “H” to “L”(open collector output). Hysteresis of 50mV(typ.) set to the detecting voltage to prevent the output chattering. The detecting voltage varies depending on SEL terminal as follows:

SEL pin	Detect voltage	Return voltage
L	2.2V(typ.)	2.25V(typ.)
High-Z	1.8V(typ.)	1.85V(typ.)

〈 Reset circuit 〉

Upon 90% of DC/DC converter output voltage, RESET terminal varies from “L” to “H” and AMUTE terminal changes from “H” to “L”. Hysteresis of 50mV(typ.) set to the reset voltage to prevent the output chattering.

〈 Charging circuit 〉

The power supply of the charging unit is CHGVCC terminal and it is independent of any other circuits. Charging current is set by the resistance between RCHG terminal and GND. The charging current takes constant current through SEL terminal.

This circuit has a private thermal shutdown circuit. When the chip temperature has been 150°C, the charging current is cut. When the chip temperature has dropped to 120°C, the charging current begins to flow.

Package Outlines (units:mm): QFP-44

