

AT731

White LED Step-Up Converter



Immense Advance Tech.

FEATURES

- Inherently Matched LED Current
- High Efficiency: 84% Typical
- Drives Up to Four LEDs from a 3.2V Supply
- Drives Up to Eight LEDs from a 5V Supply
- 36V Rugged Bipolar Switch
- Fast 1.2MHz Switching Frequency
- Uses Tiny 1mm Tall Inductors
- Requires Only 0.22μF Output Capacitor

APPLICATION

- Cellular Phones
- PDAs, Handheld Computers
- Digital Cameras
- Mp3 Players
- GPS Receivers

DESCRIPTION

The AT731 is a step-up DC/DC converter specifically designed to drive white LEDs with a constant current. The device can drive two, three or four LEDs in series from a Li-Ion cell. Series connection of the LEDs provides identical LED currents resulting in uniform brightness and eliminating the need for ballast resistors. The output capacitor can be as small as 0.22μF, saving space versus alternative solutions. A low 95mV feedback voltage minimizes power loss for better efficiency.

The AT731 are available in SOT-25 and SOT-353 packages.

ORDER INFORMATION

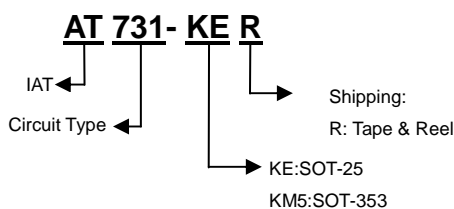

PIN CONFIGURATIONS (TOP VIEW)

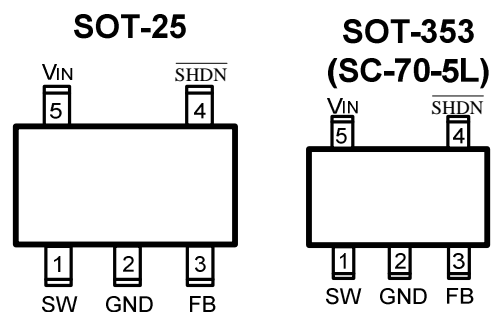

AT731

White LED Step-Up Converter



Immense Advance Tech.

PIN DESCRIPTIONS

Pin Name	Pin Description
SW	Switch Pin (Minimize trace area at this pin to reduce EMI)
GND	Ground Pin. Connect directly to local ground plane.
FB	Feedback Pin. Reference voltage is 95 mV. (Calculate resistor value according to the formula $R_{FB}=95 \text{ mV} / I_{LED}$.)
$\overline{\text{SHDN}}$	Feedback Pin. Reference voltage is 95 mV. (Calculate resistor value according to the formula $R_{FB}=95 \text{ mV} / I_{LED}$.)
V_{IN}	Input Supply Pin. (Must be locally bypassed.)

TYPICAL APPLICATION CIRCUITS

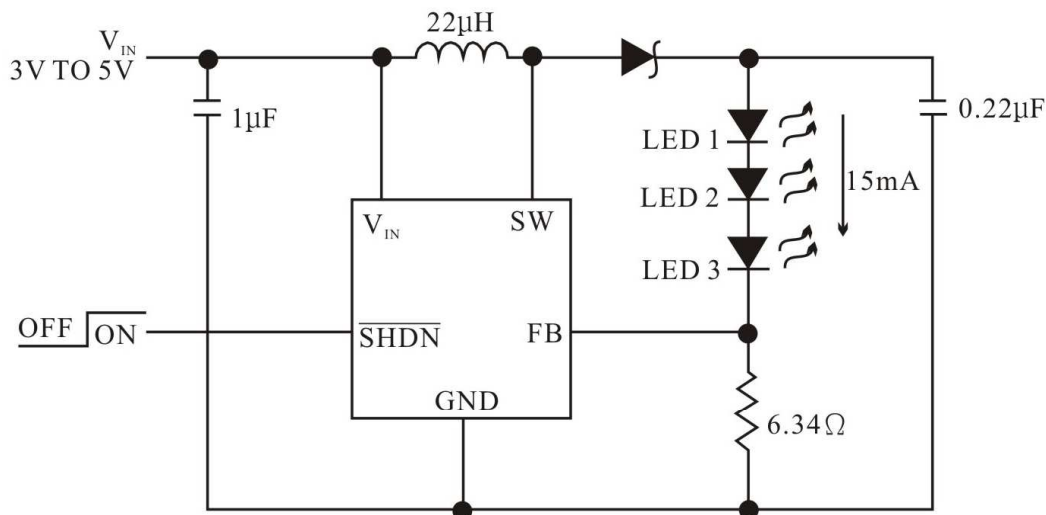
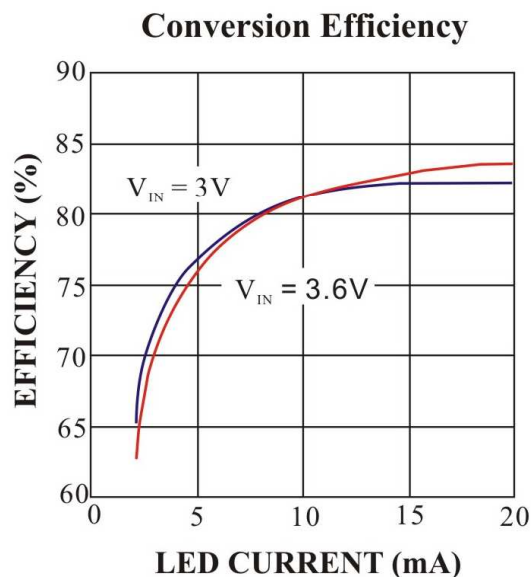

Figure 1. Li-Ion Powered Driver for Three White LEDs



AT731

White LED Step-Up Converter



Immense Advance Tech.

BLOCK DIAGRAM

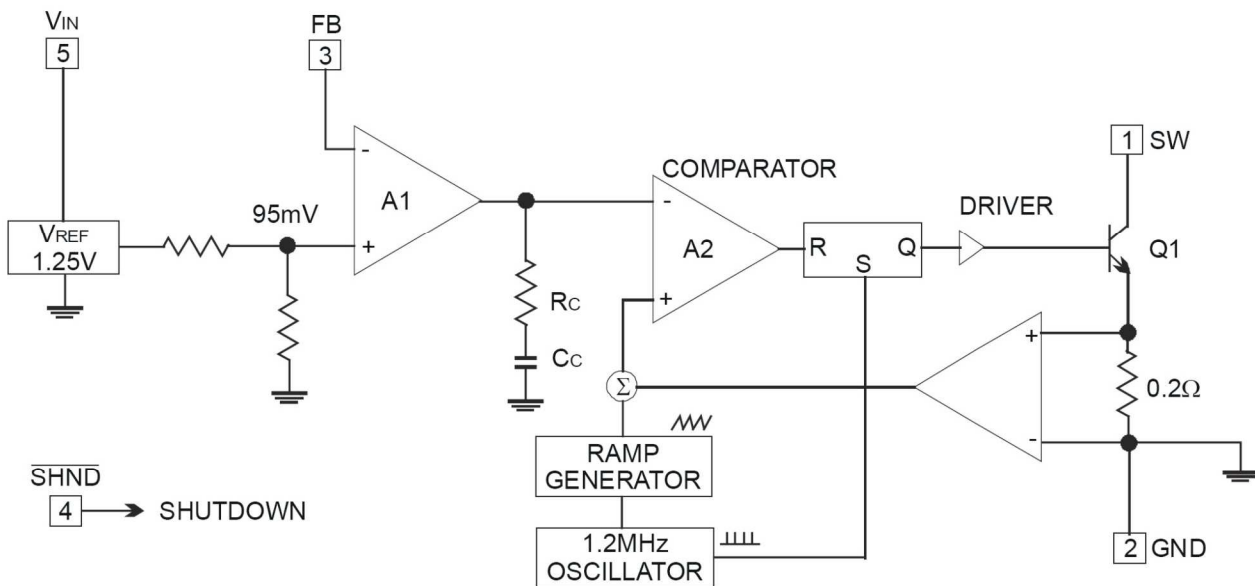

Figure 2. Block Diagram AT731

ABSOLUTE MAXIMUM RATINGS (Note 1)

Parameter	Symbol	Max Value	Unit
Input Voltage	V_{IN}	10	V
SW Voltage	V_{SW}	36	V
FB Voltage	V_{FB}	10	V
\overline{SHDN} Voltage	$V_{\overline{SHDN}}$	10	V
Power Dissipation in Free Air	P_d	300	mW
Operating Temperature Range (Note 2)	T_A	-40 to 85	°C
Maximum Junction Temperature	T_J	125	°C
Storage Temperature Range	T_{STG}	-65 to 150	°C
Lead Temperature(Soldering, 10sec)	T_{LEAD}	260	°C

Note 1: Stresses listed as the above “Absolute Maximum Ratings” may cause permanent damage to the device. These are for stress ratings. Functional operation of the device at these or any other conditions beyond those indicated in the operational sections of the specifications is not implied. Exposure to absolute maximum rating conditions for extended periods may remain possibility to affect device reliability.

Note 2: The AT731 is guaranteed to meet specifications from 0°C to 70°C. Specifications over the -40°C to 85°C operating temperature range and assured by design, characterization and correlation with statistical process controls

AT731

White LED Step-Up Converter



Immense Advance Tech.

ELECTRICAL CHARACTERISTICS

$T_A = 25^\circ\text{C}$, $V_{IN} = 3\text{V}$, $V_{\overline{\text{SHDN}}} = 3\text{V}$, unless otherwise noted.

Parameter	Conditions	Min	Typ	Max	Unit
Minimum Operating Voltage		2.5	—	—	V
Maximum Operating Voltage		—	—	10	V
Feedback Voltage	$I_{SW} = 100\text{mA}$, Duty Cycle = 66%	86	95	104	mV
FB Pin Bias Current		100	45	100	nA
Supply Current		—	1.9	2.5	mA
	$\overline{\text{SHDN}} = 0\text{V}$		0.1	1.0	μA
Switching Frequency		0.8	1.2	1.6	KHz
Maximum Duty Cycle		85	90	—	%
Switch Current Limit		—	320	—	mA
Switch V_{CESAT}	$I_{SW} = 250\text{mA}$	—	350	—	mV
Switch Leakage Current	$V_{SW} = 5\text{V}$	—	0.01	5	μA
$\overline{\text{SHDN}}$ Voltage High		1.5	—	—	V
$\overline{\text{SHDN}}$ Voltage Low		—	—	0.4	V
$\overline{\text{SHDN}}$ Pin Bias Current		—	65	—	μA

TYPICAL CHARACTERISTICS

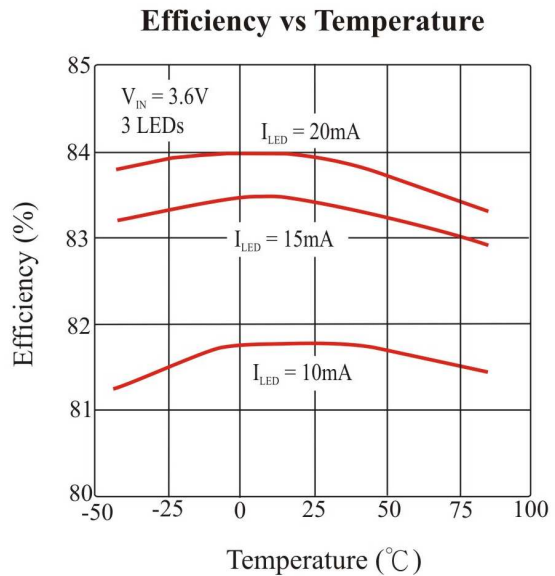
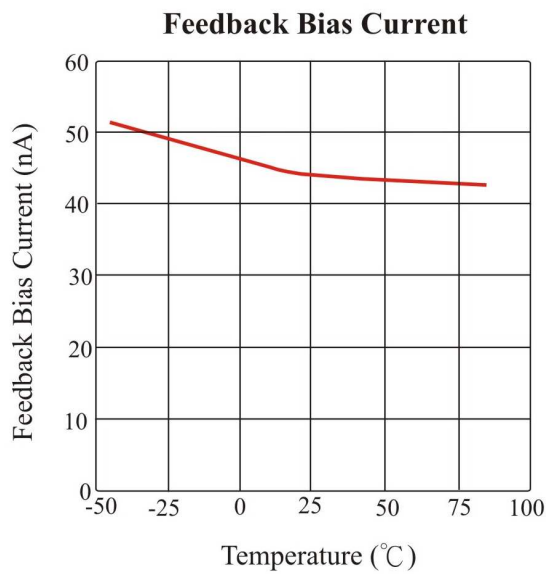
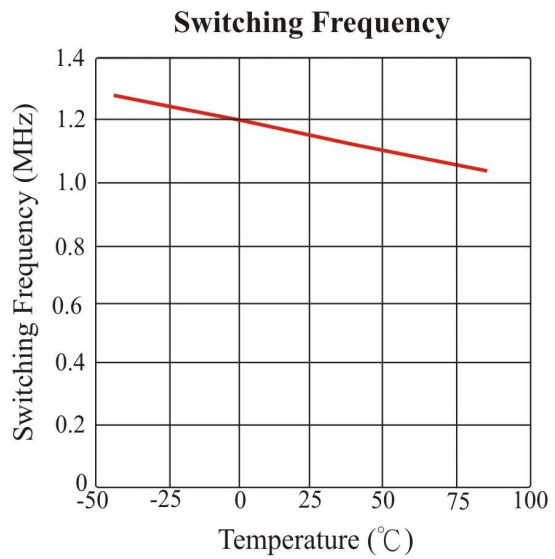
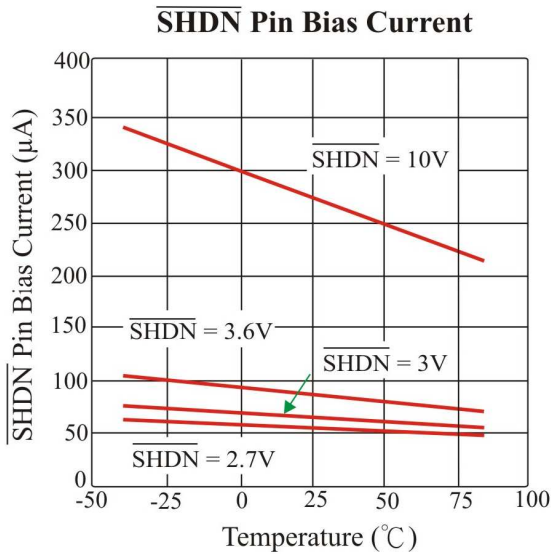

APPLICATION INFORMATION OPERATION

The AT731 uses a constant frequency, current mode control scheme to provide excellent line and load regulation. Operation can be best understood by referring to the block diagram in Figure 2. At the start of each oscillator cycle, the SR latch is set, which turns on the power switch Q1. A voltage proportional to the switch current is added to a stabilizing ramp and the resulting sum is fed into the positive terminal of the PWM comparator A2. When this voltage exceeds the level at the negative input of A2, the SR latch is reset turning off the power switch. The level at the negative input of A2 is set by the error amplifier A1, and is simply an amplified version of the difference between the feedback voltage and the reference voltage of 95mV. In this manner, the error amplifier sets the correct peak current level to keep the output in regulation. If the error amplifier's output increases, more current is delivered to the output; if it decreases, less current is delivered. The AT731 can drive up to 4 LEDs from a 3.2V supply, up to 8 LEDs (depends on forward voltage of LED) from a 5V supply.

Minimum Output Current

The AT731 can regulate three series LEDs connected at low output currents, down to approximately 4mA from a 4.2V supply, without pulse skipping using the same external components as specified for 15mA operation. As current is further reduced, the device will begin skipping pulses. This will result in some low frequency ripple, although the LED current remains regulated on an average basis down to zero.

Inductor Selection

A 22μH inductor is recommended for most AT731 applications. Although small size and high efficiency are major concerns, the inductor should have low core losses at 1.2MHz and low DCR (copper wire resistance). Some inductors in this category with small size are listed in Table 1.

Table 1. Recommended inductors

PART NUMBER	DCR (Ω)	CURRENT RATING (mA)	MANUFACTURER
LQH3C220	0.71	250	Murata
ELJPC220KF	4.00	160	Panasonic
CDRH3D16-220	0.53	350	Sumida
LB2012B220M	1.70	75	Taiyo Yuden
LEM2520-220	5.50	125	Taiyo Yuden

Capacitor Selection

The small size of ceramic capacitors makes them ideal for AT731 applications. X5R and X7R types are recommended because they retain their capacitance over wider voltage and temperature ranges than other types such as Y5V or Z5U. A 1μF, input capacitor and a 0.222μF, output capacitor are sufficient for most AT731 applications. Recommended Ceramic Capacitor Manufacturers: Taiyo Yuden, AVX, Murata, Kemet.

Diode Selection

Schottky diodes, with their low forward voltage drop and fast reverse recovery, are the ideal choices for AT731 applications. The forward voltage drop of a Schottky diode represents the conduction losses in the diode, while the diode capacitance (CT or CD) represents the switching losses. For diode selection, both forward voltage drop and diode capacitance need to be considered.

AT731

White LED Step-Up Converter



Schottky diodes with higher current ratings usually have lower forward voltage drop and larger diode capacitance, which can cause significant switching losses at the 1.2MHz switching frequency of the AT731. A Schottky diode rated at 100mA to 200mA is sufficient for most AT731 applications. Some recommended Schottky diodes are listed in Table 2.

Table 2. Recommended Schottky Diodes

PART NUMBER	FORWARD CURRENT (mA)	VOLTAGE DROP (V)	DIODE CAPACITANCE (pF)	MANUFACTURER
CMDSH-3	100	0.58 at 100mA	7.0 at 10V	Central
CMDSH2-3	200	0.49 at 200mA	15 at 10V	Central
BAT54	200	0.53 at 100mA	10 at 10V	Zetex

LED Current Control

The LED current is controlled by the feedback resistor (R1 in Figure 1). The feedback reference is 95mV. The LED current is $95\text{mV}/R1$. In order to have accurate LED current, precision resistors are preferred (1% is recommended). The formula and table 3 for R1 selection are shown below. $R1 = 95\text{mV}/I_{LED}$

Table 3. R1 Resistor Value Selection

I_{LED} (mA)	R1 (Ω)
5	19.1
10	9.53
12	7.87
15	6.34
20	4.75

Open-Circuit Protection

In the cases of output open circuit, when the LEDs are disconnected from the circuit or the LEDs fail, the feedback voltage will be zero. The AT731 will the switch at a high duty cycle resulting in a high output voltage, which may cause the SW pin voltage to exceed its maximum 36V rating. A zener

Immense Advance Tech.

diode can be used at the output to limit the voltage on the SW pin (Figure 3). The zener voltage should be larger than the maximum forward voltage of the LED string. The current rating of the zener should be larger than 0.1mA.

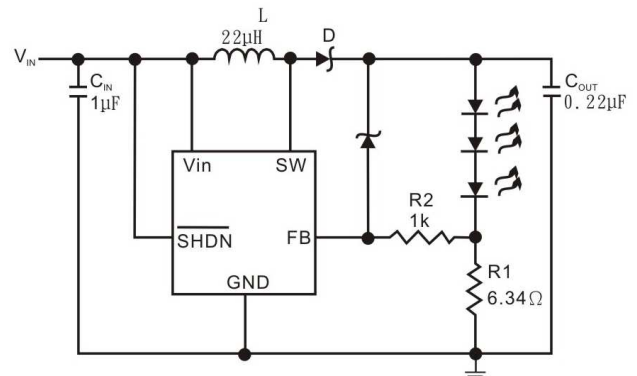

Figure 3. LED Driver with Open-Circuit Protection

Dimming Control

There are some different types of dimming control circuits:

1. Using a PWM Signal to SHDN Pin

With the PWM signal applied to the SHDN pin, the AT731 is turned on or off by the PWM signal. The LEDs operate at either zero or full current. The average LED current increases proportionally with the duty cycle of the PWM signal. A 0% duty cycle will turn off the AT731 and corresponds to zero LED current. A 100% duty cycle corresponds to full current. The typical frequency range of the PWM signal is 1kHz to 10kHz. The magnitude of the PWM signal should be higher than the minimum SHDN voltage high.

2. Using a DC Voltage

For some applications, the preferred method of brightness control is a variable DC voltage to adjust the LED current. The dimming control using a DC voltage is shown in Figure 4. As the DC

Board Layout Consideration

As with all switching regulators, careful attention must be paid to the PCB board layout and component placement. To maximize efficiency, switch rise and fall times are made as short as short as possible. To prevent electromagnetic interference (EMI) problems, proper layout of the high frequency switching path is essential. The voltage signal of the SW pin has sharp rise and fall edges. Minimize the length and area of all traces connected to the SW pin and always use a ground plane under the switching regulator to minimize interplane coupling. In addition, the ground connection for the feedback resistor R1 should be tied directly to the GND pin and not shared with any other component.

voltage increases, the voltage drop on R2 increases and the voltage drop on R1 decreases. Thus, the LED current decreases. The selection of R2 and R3 will make the current from the variable DC source much smaller than the LED current and much larger than the FB pin bias current. For VDC range from 0V to 2V, the selection of resistors in Figure 4 gives dimming control of LED current from 0mA to 15mA.

3. Using a Filtered PWM signal

The filtered PWM signal can be considered as an adjustable DC voltage. It can be used to replace the variable DC voltage source in dimming control. The circuit is shown in Figure 5.

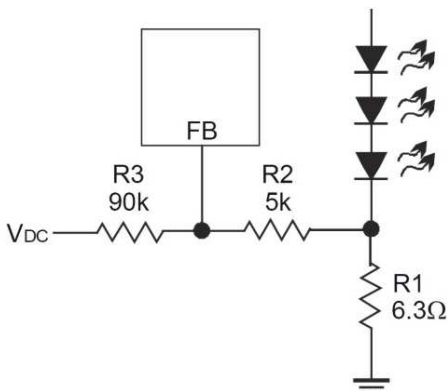

Figure 4. Dimming Control Using a DC Voltage

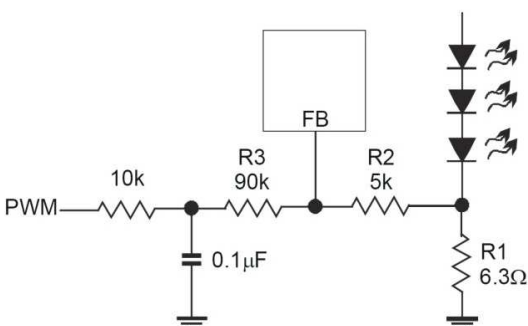

Figure 5. Dimming Control Using a Filtered PWM Signal

AT731

White LED Step-Up Converter



Immense Advance Tech.

PACKAGE OUTLINE DIMENSIONS SOT-25 PACKAGE OUTLINE DIMENSIONS

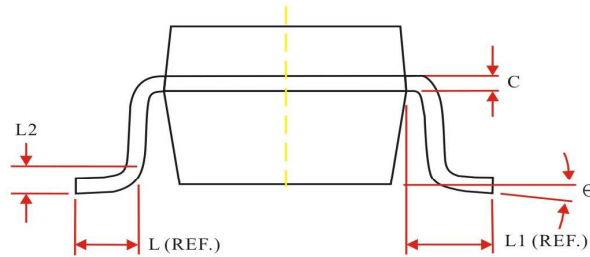
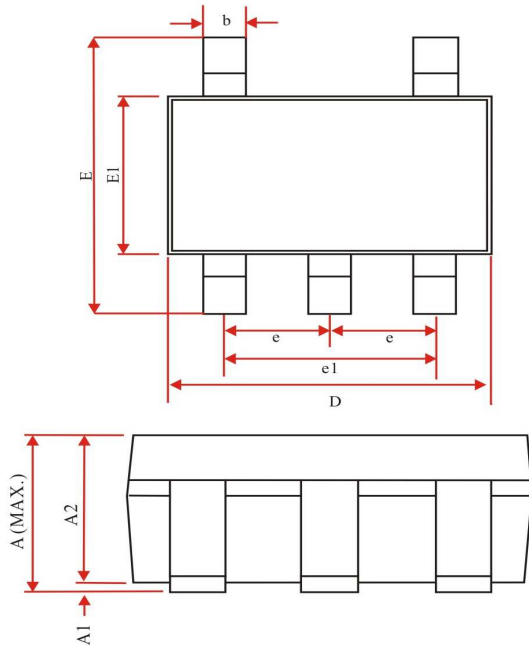

Symbol	Dimensions In Millimeters	
	Min	Max
A	1.45 MAX.	
A1	0	0.15
A2	0.90	1.30
C	0.08	0.22
D	2.90 BSC.	
E	2.80 BSC.	
E1	1.60 BSC.	
L	0.30	0.60
L1	0.60BSC.	
L2	0.25BSC.	
θ	0°	10°
b	0.30	0.50
e	0.95BSC.	
e1	1.90BSC.	

SOT-353 PACKAGE OUTLINE DIMENSIONS

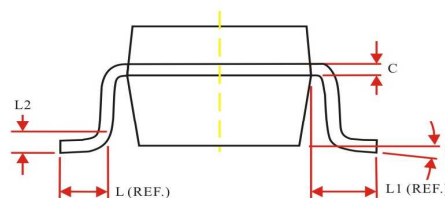
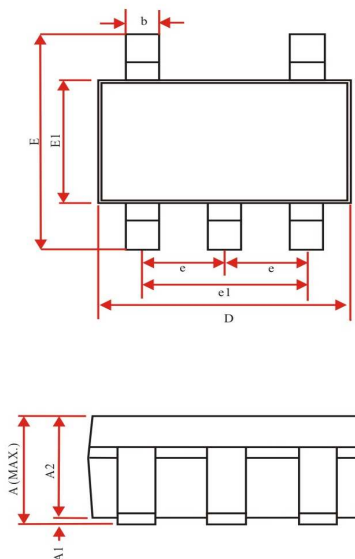

Symbol	Dimensions In Millimeters	
	Min	Max
A	1.10 MAX.	
A1	0	0.10
A2	0.70	1.00
C	0.08	0.22
D	2.00 BSC.	
E	2.10 BSC.	
E1	1.25 BSC.	
L	0.26	0.46
L1	0.525REF.	
L2	0.15BSC.	
θ	0°	8°
b	0.15	0.35
e	0.65BSC.	
e1	1.30BSC.	

Note :

Information provided by IAT is believed to be accurate and reliable. However, we cannot assume responsibility for use of any circuitry other than circuitry entirely embodied in an IAT product; nor for any infringement of patents or other rights of third parties that may result from its use. We reserve the right to change the circuitry and specifications without notice.

Life Support Policy: IAT does not authorize any IAT product for use in life support devices and/or systems. Life support devices or systems are devices or systems which, (I) are intended for surgical implant into the body or (II) support or sustain life, and whose failure to perform, when properly used in accordance with instructions for use provided in the labeling, can be reasonably expected to result in a significant injury to the user. Typical numbers are at 25°C and represent the most likely norm.