

Features

- High Performance, Low-power AVR[®] 8-bit Microcontroller
 - Advanced RISC Architecture, Fully Static Operation
 - 133 Powerful Instructions – Most Single Clock Cycle
 - 32 x 8 General Purpose Working Registers
 - On-chip Two-cycle Multiplier
- 32 KBytes Extended Life Flash
 - Program and Data Storage
 - Endurance: 100,000 Write/Erase Cycles
 - In-system, Self-programming Capability
 - Code Security Options via Fuse Bits
- 8 KBytes of Internal SRAM
- 8 KBytes of Mask-Programmable ROM
 - Includes Boot-load Mode for Flash Programming
- JTAG Interface (IEEE 1149.1 Compliant)
 - Extensive On-chip Debug Support
 - Programming of Flash through JTAG Interface
- 128-bit Advanced Encryption Standard (AES) Engine
- NIST-certified Random Number Generator
- Cyclic Redundancy Check (CRC) Generator
- Low-power, 4-channel, 10-bit ADC
 - Optional Band-gap or External Voltage References
 - Power-down Mode
- Buffered Serial TX and RX Ports
- Dual Master/Slave SPI Serial Interfaces
- Programmable UART with Numerous Supported Baud Rates
- 32 General Purpose I/O with Programmable Pull-ups
- Programmable Watchdog Timer
- Four 16-bit Timer/Counters with Pre-scalar, PWM Capability
- Modulo 20 Counter
- Low-power, On-chip Oscillators (3–20 MHz and 32 kHz)
- External Clock Output (for driving transceiver clock)
- Power-on Reset
- High Precision, Programmable Brown-out Detection
- Operating Voltage: 2.7 to 3.6V
- Packages: 64-lead TQFP and 64-ball LFBGA

Applications

- Wireless System Control (including IEEE 802.15.4/ZigBee)
- Security Protocol Processing
- Building/Home Automation (e.g., Lighting, HVAC, Security)
- Industrial Controls and Sensors
- Wireless PC Peripherals (e.g., Mouse, Keyboard, Joystick)
- Consumer Electronics, Remote Controls, and Toys
- Inventory Management
- Health Monitoring

Description

The Atmel AT86ZL3201 Z-Link[™] Controller is a low-power CMOS 8-bit microcontroller based on the AVR-enhanced RISC architecture. Similar in function to Atmel's popular ATmega128 and other AVR standard microcontrollers, the Z-Link Controller is customized for systems supporting the new IEEE 802.15.4 standard for Low Rate, Wireless, Personal Area Networks (LR-WPANs) and the emerging ZigBee wireless network protocol based on that standard. The ZigBee Alliance, an association of over 50 companies, is developing ZigBee to ensure interoperability of devices from different manufacturers, to enhance security and supported network topologies, and to establish testing and certification of compliant products.



AT86ZL3201 Z-Link[™] Controller

8-bit AVR[®]
Microcontroller
Customized for
IEEE 802.15.4 and
ZigBee[™]
Wireless Systems

Preliminary Summary

5056CS-WIRE-6/04



Note: This is a summary document. A complete document is not available at this time. For more information, please contact your local Atmel sales office.



In addition to many powerful features commonly found on Atmel's AVR microcontrollers, the Z-Link Controller includes a 128-bit Advanced Encryption Standard (AES) engine and a NIST-certified random number generator to provide low-cost, low-power network security that conserves program space. With buffered TX and RX ports, two SPI serial interface blocks, 32 general purpose I/O with programmable pull-ups, numerous clocking options, and a high-speed clock output, the Z-Link Controller is designed with a flexible interface to support both low-band (868/915 MHz) and high-band (2.4 GHz) radio solutions.

For power conservation, the Z-Link Controller includes two sleep modes, a power-down mode for the ADC, and a programmable brown-out detector. In sleep mode, one 16-bit timer can be running with the extremely low-power 32-kHz oscillator (max. 1uW), and all analog blocks have low-power, standby modes.

The Z-Link Controller includes many features to aide in software development, including a JTAG-compliant interface for on-chip debug and flash programming, and four 16-bit timers.

The 32 KB Flash can be programmed in the system via the built-in bootloader using data directly from either SPI interface or via ROM-code using data from some other source such as RF data (for over-the-air programming). Code security options include the ability to establish a variable-sized, protected section of Flash memory and the ability to lock out JTAG access.

The Z-Link Controller will include a proven IEEE 802.15.4 software stack including both the PHY and the MAC protocol layers. In addition, the Z-Link Controller will be supported with a full suite of program and system development tools including C compiler, macro assembler, program debugger/simulator, in-circuit emulator, and an evaluation kit.

Figure 1. Block Diagram

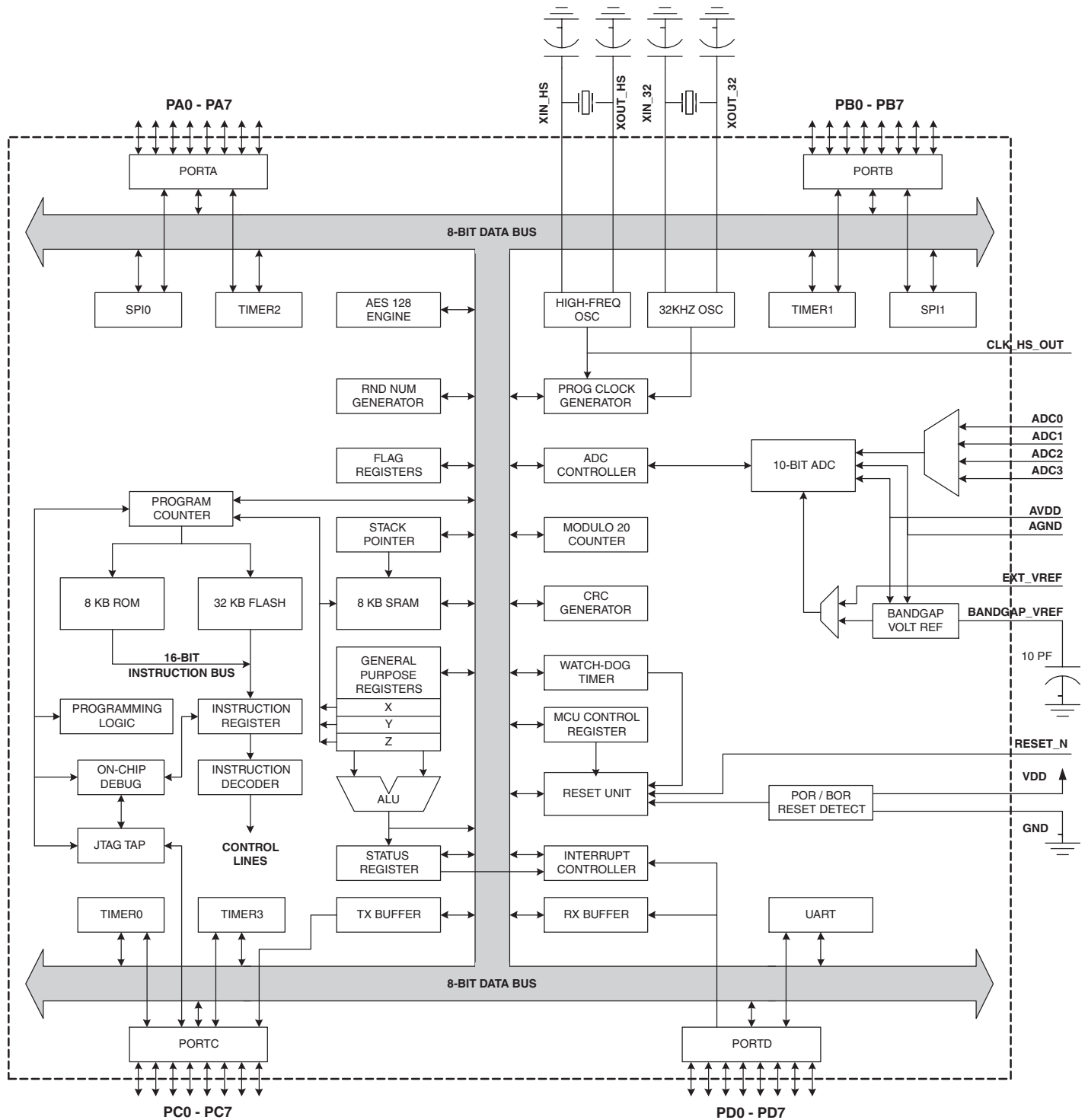



Atmel Corporation

2325 Orchard Parkway
San Jose, CA 95131, USA
Tel: 1(408) 441-0311
Fax: 1(408) 487-2600

Regional Headquarters

Europe

Atmel Sarl
Route des Arsenalux 41
Case Postale 80
CH-1705 Fribourg
Switzerland
Tel: (41) 26-426-5555
Fax: (41) 26-426-5500

Asia

Room 1219
Chinachem Golden Plaza
77 Mody Road Tsimshatsui
East Kowloon
Hong Kong
Tel: (852) 2721-9778
Fax: (852) 2722-1369

Japan

9F, Tonetsu Shinkawa Bldg.
1-24-8 Shinkawa
Chuo-ku, Tokyo 104-0033
Japan
Tel: (81) 3-3523-3551
Fax: (81) 3-3523-7581

Atmel Operations

Memory

2325 Orchard Parkway
San Jose, CA 95131, USA
Tel: 1(408) 441-0311
Fax: 1(408) 436-4314

Microcontrollers

2325 Orchard Parkway
San Jose, CA 95131, USA
Tel: 1(408) 441-0311
Fax: 1(408) 436-4314

La Chantrerie
BP 70602
44306 Nantes Cedex 3, France
Tel: (33) 2-40-18-18-18
Fax: (33) 2-40-18-19-60

ASIC/ASSP/Smart Cards

Zone Industrielle
13106 Rousset Cedex, France
Tel: (33) 4-42-53-60-00
Fax: (33) 4-42-53-60-01

1150 East Cheyenne Mtn. Blvd.
Colorado Springs, CO 80906, USA
Tel: 1(719) 576-3300
Fax: 1(719) 540-1759

Scottish Enterprise Technology Park
Maxwell Building
East Kilbride G75 0QR, Scotland
Tel: (44) 1355-803-000
Fax: (44) 1355-242-743

RF/Automotive

Theresienstrasse 2
Postfach 3535
74025 Heilbronn, Germany
Tel: (49) 71-31-67-0
Fax: (49) 71-31-67-2340

1150 East Cheyenne Mtn. Blvd.
Colorado Springs, CO 80906, USA
Tel: 1(719) 576-3300
Fax: 1(719) 540-1759

Biometrics/Imaging/Hi-Rel MPU/ High Speed Converters/RF Datacom

Avenue de Rochepleine
BP 123
38521 Saint-Egreve Cedex, France
Tel: (33) 4-76-58-30-00
Fax: (33) 4-76-58-34-80

Literature Requests

www.atmel.com/literature

Disclaimer: Atmel Corporation makes no warranty for the use of its products, other than those expressly contained in the Company's standard warranty which is detailed in Atmel's Terms and Conditions located on the Company's web site. The Company assumes no responsibility for any errors which may appear in this document, reserves the right to change devices or specifications detailed herein at any time without notice, and does not make any commitment to update the information contained herein. No licenses to patents or other intellectual property of Atmel are granted by the Company in connection with the sale of Atmel products, expressly or by implication. Atmel's products are not authorized for use as critical components in life support devices or systems.

© Atmel Corporation 2004. All rights reserved. Atmel® and combinations thereof and AVR® are registered trademarks and Z-Link™ is a trademark of Atmel Corporation or its subsidiaries. ZigBee™ is a trademark of the ZigBee Alliance. Other terms and product names may be the trademarks of others.



Printed on recycled paper.

5056CS-WIRE-6/04