

# ATCA-7368

## AdvancedTCA Processor Blade

■ Embedded Computing for  
Business-Critical Continuity™

**The ATCA-7368 processor blade is an ideal solution for communications equipment requiring powerful processing performance, flexible I/O functionality plus mass storage and network options**

- High performance Intel® Architecture processor blade designed for cost-sensitive applications
- One 6-core Intel® Xeon® processor L5638 (2.0 GHz)
- Up to 48GB main memory
- One mid-size AMC site supporting offload, storage & I/O
- Cost-effective on-board SATA drive option
- Hot-swappable hard disk with flexible choice of storage options via RTM
- RAID 0/1 support
- Multiple storage and I/O connectivity
- PICMG 3.1 Option 1, 9 (1/10GbE) ATCA fabric interface
- Designed for NEBS and ETSI compliance
- Multiple software packages including operating systems

The Emerson Network Power ATCA-7368 is an Intel® Architecture general-purpose blade that delivers a combination of performance and flexibility to help drive the successful implementation of next-generation telecom networks and communication infrastructures. It builds on the AdvancedTCA® (ATCA®) standard to provide the right product at the right time to meet the needs of communication industries.

With one 6-core Intel® Xeon® processor L5638 and one AdvancedMC™ (AMC) site, the ATCA-7368 processor blade enables highest compute performance and I/O functionality in an ATCA form factor. The AMC site features mid-size, single wide AMCs and provides flexible connectivity for storage and I/O. The PICMG® 3.1 compliant fabric interface provides 10 Gigabit Ethernet (10Gbps) capabilities for applications requiring higher network throughput in the backplane.

Multiple network and storage I/O interfaces, supported by the RTM-ATCA-7368, allow the integration into different network infrastructures such as telecommunication central offices and network data centers. Main memory configuration and mass storage options can be flexibly configured providing a perfect fit to the application's needs. Hardware RAID 0 and 1 is supported for locally and externally connected disk drives in conjunction with an appropriate RTM.



**AdvancedTCA®**

  
**EMERSON™**  
Network Power

### ATCA-7368 Block Diagram

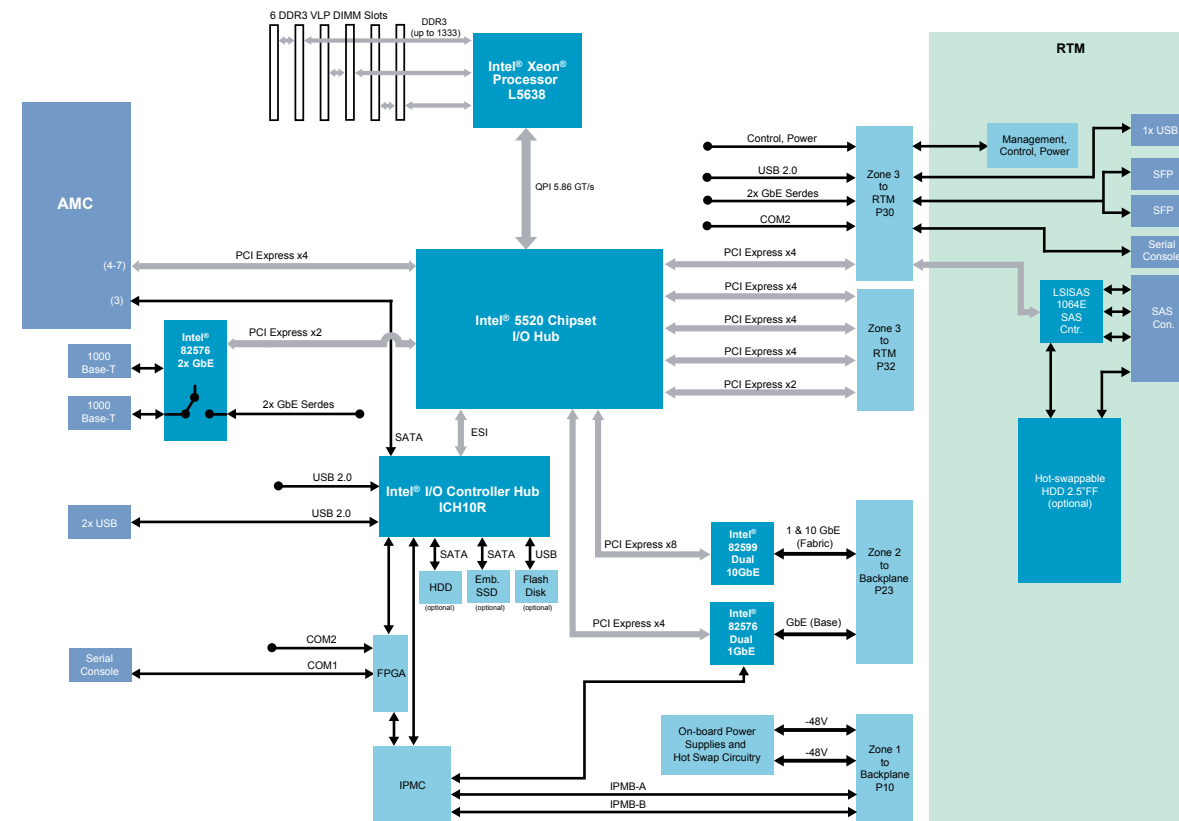

### Standard Networking Support

The ATCA-7368 processor blade provides PICMG 3.0 redundant base interface connectivity in a dual star configuration using standard Gigabit Ethernet (GbE) technology. The PICMG 3.1 fabric interface features both dual 10Gbps (Option 9) and dual 1Gbps (Option 1) Ethernet capability. External network connectivity includes two 10/100/1000Base-T Ethernet via RJ-45 connectors on the blade faceplate.

### Processor Complex

The Intel® Xeon® processors L5638 can access the entire I/O subsystem via the Intel® 5520 chipset I/O hub. The I/O subsystem consists of:

- Intel® I/O Controller Hub ICH10R
- Intel® 82576 dual Gigabit Ethernet controllers
- Intel® 82599 dual 10 Gigabit Ethernet controller
- LSI Logic LSISAS1064E SAS controller (on optional RTM)

### Software Support

The ATCA-7368 blade can be configured with a variety of software offerings, from firmware-only to fully integrated and verified software operating environments.

#### FIRMWARE

Firmware-only blade-level support is offered for customers taking on the integration and verification responsibilities. It provides all the boot and IPMC firmware required for an ATCA blade. The BIOS firmware includes support for:

- Unified Extensible Firmware Interface (UEFI)
- Power management support, ACPI 3.0b
- Multiple boot options including:
  - Local and external hard disks
  - On-board flash disk
  - External USB boot media
  - PXE boot via ATCA base interface and front panel Ethernet interface
  - iSCSI boot via ATCA base interface and external networks with operating systems supporting UEFI

- RAID 0/1 support via LSI SAS BIOS extension
- Serial redirection of the BIOS console
- Serial over LAN of the BIOS console via ATCA base interface
- BIOS upgrade via local host

#### INTELLIGENT PLATFORM MANAGEMENT CONTROL

The ATCA-7368 features an intelligent platform management controller (IPMC). The IPMC is a management subsystem providing monitoring, event logging, and recovery control. The IPMC serves as the gateway for management applications to access the platform hardware. Features include:

- Compliance with PICMG 3.0 and IPMI 1.5
- Rollback capability if IPMC image upgrade failed
- Firmware (BIOS, IPMC, FPGA) upgradeable from IPMI interface (IPMB) and/or locally, PICMG HPM.1 support or via Basic Blade Services (BBS) firmware upgrade utility
- Support for serial port redirection over LAN interface (IPMI 2.0 compliant)

#### SUPPORTED OPERATING SYSTEMS

- Red Hat RHEL 6.1 certified
- Wind River PNE LE 4.0
- Prepared for Microsoft® Windows® Server 2008
- Prepared for VMware ESX/ESXi (requires VGA on AMC module)

To better exploit the CPU and I/O resources of the blade, RHEL 6.1 supports CPU and I/O virtualization using KVM. In addition RHEL 6.1 provides code for enabling the processor power management to help enhance the energy efficiency of the blade. Emerson ATCA blades can be configured with optional software that includes Basic Blade Services. The ATCA-7368 is verified with Wind River PNE 4.0. This distribution comes with all Linux Support Packages (LSPs) to support Emerson ATCA blades as well as user applications. Basic Blades Services (BBS) software is provided to enable a set of ATCA hardware and software components into a fully integrated and verified telecom platform.

Basic Blade Services include:

- Hardware Platform Management including local IPMC, LED, E-Keying and blade extraction software
- Firmware upgrade utility
- Local management access (CLI)
- Blade device drivers
- HPI client library

#### RELEVANT STANDARDS

- Linux Foundation
- Service Availability Forum™ (SA Forum)
  - Hardware Platform Interface (HPI) – HPI-B.02

Please check with your local sales contact for availability of supported Centellis™ platforms.

### Rear Transition Modules

RTM-ATCA-7368 includes:

- One (1) USB 2.0 interface
- Two (2) Ethernet interfaces with SFP
- Four (4) SAS interfaces (three from controller, one from HDD), SFF-8470 connector
- Disk bay for one (1) hot-swappable hard disk, 2.5"

### Hardware

#### PROCESSOR

- One 6-core Intel® Xeon® processor L5638 (2.0 GHz)
- QuickPath Interface (QPI) – 5.86 GT/s
- 12MB L3 cache (per processor)
- 64-bit mode extension (EM64T)
- SMP support

#### MEMORY

- DDR3-800/1066/1333 memory controllers integrated into processor
- Total of three independent memory channels
- From 2 to 48GB memory configurations supported
- 4MB primary firmware flash, 4MB redundant flash for failsafe operation
- Reset persistent memory, 16MB SRAM, 64MB flash (optional) Note 1

#### MASS STORAGE

- Embedded USB flash disk, 4GB (optional)
- On-board 80GB SATA disk with extended temperature range for variants without AMC site (optional)

- On-board solid state disk at SATA, 32GB, 64GB, or 120GB (optional) Note 1
- Hot-swappable hard disk on RTM (optional)
- RTM hard disk drive options including
  - ▲ Enterprise class disks (various capacity options)

**BASE AND FABRIC INTERFACES**

- Dual star configuration
- PICMG 3.0 base interface compliant, Gigabit Ethernet (1.0Gbps)
- PICMG 3.1 fabric interface compliant
  - ▲ PICMG 3.1, Option 1 – Single, redundant Gigabit Ethernet pair (1.0Gbps)
  - ▲ PICMG 3.1, Option 9 – Single, redundant 10 Gigabit Ethernet pair (10Gbps)

**COUNTERS /TIMERS**

- Real-time clock
- Programmable watchdog timer

**AMC SITES**

- One (1) mid-size AMC slot (PICMG AMC.0, AMC.1 and AMC.3 compliant)
- Connectivity
  - ▲ PCI Express (x4) interface
  - ▲ One (1) SATA interface
- PCI Express hot-plug support

**EXTERNAL INTERFACES**

- Front panel
  - ▲ 10/100/1000Base-T Ethernet (2), RJ-45
  - ▲ Serial console (1), RJ-45
  - ▲ USB 2.0 (2)
- Rear transition module
  - ▲ 1Gb Ethernet (2), SFP
  - ▲ Serial console (1), RJ-45
  - ▲ USB 2.0 (1)
  - ▲ SAS interfaces (4), SFF-8470

**POWER REQUIREMENTS**

- Dual-redundant -48 to -60 VDC (TNV-2) rail
- Input range: -39 to -72 VDC
- Power consumption without AMC - Maximum: 145 W

**THERMAL CHARACTERISTICS**

- Operating range: -5 °C to 55 °C
- Airflow requirements according to CP-TA B.3/4, depending on blade configuration and maximum processor clock

**RELEVANT BLADE SIZE**

- 8U form factor, 280 mm X 322.5 mm, single slot

**RELEVANT STANDARDS**

- PICMG 3.0 (form factor, IPMI, base interface, hot swap, RTM)
- PICMG 3.1, Option 1, 9
- PICMG AMC.0, AMC.1 and AMC.3

**Ordering Information**

Part Number	Description
ATCA-7368-0GB	ATCA processor blade, L5638 6-core (2.0 GHz), 0GB, 10G support, AMC site, no flash. See Note 1 & 2
ATCA-7368-0GB-LS	ATCA processor blade, L5638 6-core (2.0 GHz), 0GB, 10G support, SATA drive site, no flash. See Note 2
ATCA7367-HDD1-SATA	80GB SATA HDD (ext. temp.) kit for on-board use with ATCA-7367-0GB-LS or ATCA-7368 variants with SATA drive site
ATCA-7360-MEM-2G	2GB DDR3 VLP memory module for ATCA-736X product series
ATCA-7360-MEM-4G	4GB DDR3 VLP memory module for ATCA-736X product series
ATCA-7360-MEM-8G	8GB DDR3 VLP memory module for ATCA-736X product series
RTM-ATCA-7368	RTM for the ATCA-7368 product series, 2X GbE (SFP), 4X SAS, 1X slot for optional HDD
ATCA7368-HDD1-SAS	300GB SAS HDD for the RTM-ATCA-7368
ATCA7368-HDD2-SAS	600GB SAS HDD for the RTM-ATCA-7368
ATCA-736X-USB1	4GB eUSB device for ATCA-736X product series
ATCA7360-MMOD-SATA1	32GB on-board solid state disk at SATA for ATCA-736X product series. See Note 3
ATCA7360-MMOD-SATA2	64GB on-board solid state disk at SATA for ATCA-736X product series. See Note 3
ATCA7360-MMOD-SATA3	120GB on-board solid state disk at SATA for ATCA-736X product series. See Note 3
ATCA7360-SFMMOD	Reset persistent memory, 16MB SRAM, 64MB flash for the ATCA-736X product series. See Note 3
AMC-FILLER-MS	AMC filler panel mid-size
RJ45-DSUB-ATCA	RJ-45 DSUB cable for the ATCA-7140, 7X50, 736X, 737X, 747X blades
SA-BBS-WR40-7368	CD - BBS SW and WR PNE 4.0 for ATCA-7368. See Note 4

Note 1: AMC filler panel not included

Note 2: No memory installed

Note 3: Persistent memory and solid state disk mutually exclusive

Note 4: License for a single blade

Note 1: Persistent memory and solid state disk mutually exclusive

Regulatory Compliance	
Item	Description
Designed to comply with NEBS, Level 3	Telcordia GR-63-CORE, NEBS Physical Protection
	Telcordia GR-1089-CORE, Electromagnetic Compatibility and Electrical Safety – Generic Criteria for Network Telecommunications Equipment. Equipment Type 2
Designed to comply with ETSI	ETSI Storage, EN 300 019-1-1, Class 1.2 equipment, Not Temperature Controlled Storage Locations
	ETSI Transportation, EN 300 019-1-2, Class 2.3 equipment, Public Transportation
	ETSI Operation, EN 300 019-1-3, Class 3.1 (E) equipment, Temperature Controlled Locations
	ETSI EN 300 132-2 Environmental Engineering (EE); Power supply interface at the input to telecommunications equipment; Part 2: Operated by direct current (dc)
	ETSI ETS 300 753, Equipment Engineering (EE); Acoustic noise emitted by telecommunications equipment
CE Conformity	Directive 2004/108/EC, Directive 2006/95/EC
EMC	ETSI EN 300 386 Electromagnetic compatibility and Radio spectrum Matters (ERM); telecommunication network equipment; ElectroMagnetic Compatibility (EMC) requirements, Telecommunication equipment room (attended)
	CFR 47 FCC Part 15 Subpart B, Class A (US); FCC Part 15 - Radio Frequency Devices; Subpart B: Unintentional Radiators
	AS/NZS CISPR 22 (Australia/New Zealand), Limits and Methods of Measurement of Radio Disturbance Characteristics of Information Technology Equipment
	VCCI Class A (Japan), Voluntary Control Council for Interference by Information Technology Equipment
	CISPR 22 Information technology equipment – Radio disturbance characteristics – Limits and methods of measurement
	CISPR 24 Information technology equipment – Immunity characteristics – Limits and methods of measurement
Safety	Certified to UL/CSA 60950-1, EN 60950-1 and IEC 60950-1 CB Scheme
	Safety of information technology equipment, including electrical business equipment
RoHS/WEEE compliance	DIRECTIVE 2002/95/EC OF THE EUROPEAN PARLIAMENT AND OF THE COUNCIL on the restriction of the use of certain hazardous substances in electrical and electronic equipment (RoHS)
	DIRECTIVE 2002/96/EC OF THE EUROPEAN PARLIAMENT AND OF THE COUNCIL on waste electrical and electronic equipment (WEEE)
Interoperability	Designed to operate within a CP-TA B.3/4 system environment depending on board configuration and maximum processor clock frequency

**SOLUTION SERVICES**

Emerson Network Power provides a portfolio of solution services optimized to meet your needs throughout the product lifecycle. Design services help speed time-to-market. Deployment services include global 24x7 technical support. Renewal services enable product longevity and technology refresh.

PICMG, AdvancedTCA, ATCA, AdvancedMC and the AdvancedTCA logo are trademarks of PICMG. Service Availability is a proprietary trademark used under license. Intel and Xeon are trademarks of Intel Corporation or its subsidiaries in the United States and other countries. Microsoft and Windows are registered trademarks of Microsoft Corporation. All other product or service names are the property of their respective owners.

This document identifies products, their specifications, and their characteristics, which may be suitable for certain applications. It does not constitute an offer to sell or a commitment of present or future availability, and should not be relied upon to state the terms and conditions, including warranties and disclaimers thereof, on which Emerson Network Power may sell products. A prospective buyer should exercise its own independent judgment to confirm the suitability of the products for particular applications. Emerson Network Power reserves the right to make changes, without notice, to any products or information herein which will, in its sole discretion, improve reliability, function, or design. Emerson Network Power does not assume any liability arising out of the application or use of any product or circuit described herein; neither does it convey any license under its patent or other intellectual property rights or under others. This disclaimer extends to any prospective buyer, and it includes Emerson Network Power's licensee, licensee's transferees, and licensee's customers and users. Availability of some of the products and services described herein may be restricted in some locations.

**Emerson Network Power.**  
The global leader in enabling  
*Business-Critical Continuity™*.

-  AC Power
-  Embedded Power
-  Precision Cooling
-  Connectivity
-  Infrastructure Management & Monitoring
-  Racks & Integrated Cabinets
-  DC Power
-  Outside Plant
-  Services
-  Embedded Computing
-  Power Switching & Controls
-  Surge Protection

**Emerson Network Power**

**Offices:** Tempe, AZ U.S.A. 1 800 759 1107 or +1 602 438 5720  
 Paris, France +33 1 60 92 31 20 • Munich, Germany +44 1509 236490 • Tel Aviv, Israel +972 99560361  
 Hong Kong +852 2176 3540 • Shanghai, China +86 21 3395 0289 • Tokyo, Japan +81 3 5403 2730 • Seoul, Korea +82 2 3483 1500

**EmersonNetworkPower.com/EmbeddedComputing**

Emerson, Business-Critical Continuity and Emerson Network Power are trademarks of Emerson Electric Co. or one of its affiliated companies. ©2011 Emerson Electric Co.