

Features

- Current-controlled Output Current Source with 4 Input Channels
- LVDS Compatible Inputs at Channels 2, 3 and 4 with On-chip 100Ω Termination
- Separate Read-channel Enable
- Two Selectable Outputs for Grounded Laser Diodes
- Output Current per Channel up to 350 mA
- Total Output Current up to 600 mA
- On-chip RF Oscillator
- Control of 2 Different Swings and Frequencies by use of 4 External Resistors
- Oscillator Frequency Range from 200 MHz to 500 MHz
- Maximum Oscillator Current Amplitude 100 mApp
- Single 5V Power Supply
- Small Pb-free QFN24, 4 mm × 4 mm Package



Applications

- DVD+/-RW Dual Layer with CD-RW Capability
- Recordable Optical Drives

1. Description

The ATR0849 is a laser diode driver designed to operate two different grounded laser diodes for DVD-RW/DVD+RW (650 nm) and CD-RW (780 nm). The device includes four channels for four different optical power levels. The write channels (channels 2 to 4) can be controlled by fast LVDS (Low Voltage Differential Signaling).

The read channel generates a continuous output current, whereas channels 2 to 4 are designed as write channels with very fast switching speed. All channels are summed together and routed to one of the two outputs, IOUTA or IOUTB, controlled by the select input, SELA. Each write channel (channel 2 to 4) can contribute up to 350 mA to the total output current of up to 600 mA. The read channel can contribute up to 150 mA. Total gains of 100 (read channel) and 250 (channels 2, 3 and 4), are provided between each reference current input and the selected output. Although the reference inputs are current inputs, voltage control is possible by using external resistors. An on-chip RF oscillator is available to reduce laser-mode hopping noise during read mode. The oscillator current amplitude can be set independently for the two selectable outputs with two different resistors. Oscillation is enabled by a high signal at the ENOSC pin. Complete shutdown of the output currents is achieved by a low signal at the ENABLE input.

In read mode, the reference currents (I2, I3, I4) should be switched off to reduce power consumption.

In case of uncertain (balanced) enable signals, a built-in fail-safe circuit will reduce the laser diode output current to a safe value.



4-Channel LVDS Laser Driver for Dual-layer Application

ATR0849

Summary

Rev. 4851BS-DVD-06/05

Figure 1-1. Block Diagram

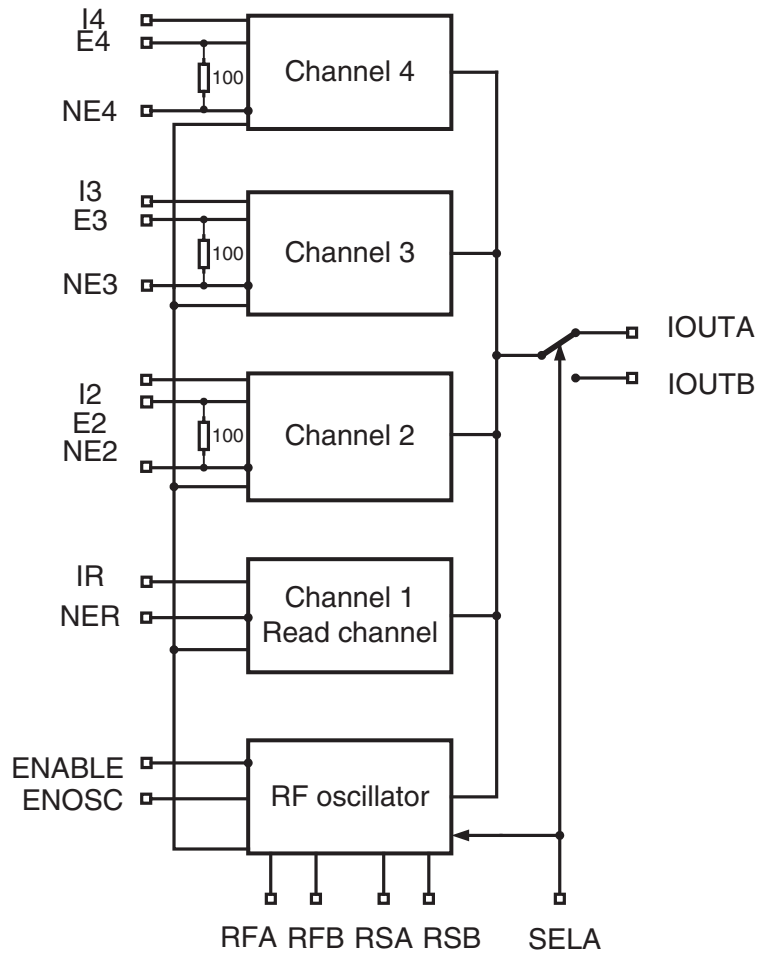

2. Pin Configuration

Figure 2-1. Pinning QFN24

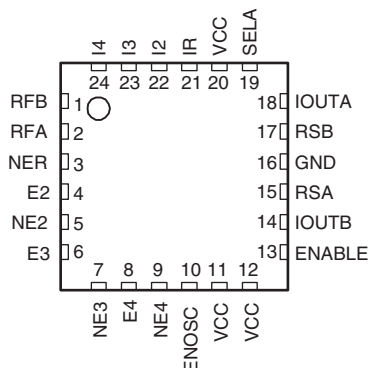

Table 2-1. Pin Description

Pin	Symbol	Type	Function
1	RFB	Analog	External resistor to GND sets frequency of oscillator B
2	RFA	Analog	External resistor to GND sets frequency of oscillator A
3	NER	Digital	Digital control of read channel (channel 1), active low
4	E2	Digital	Digital control of channel 2
5	NE2	Digital	Digital control of channel 2
6	E3	Digital	Digital control of channel 3
7	NE3	Digital	Digital control of channel 3
8	E4	Digital	Digital control of channel 4
9	NE4	Digital	Digital control of channel 4
10	ENOSC	Digital	Digital control of RF oscillator
11	VCC	Supply	+5V power supply
12	VCC	Supply	+5V power supply
13	ENABLE	Digital	Enables output current, active high
14	IOUTB	Analog	Output current source B for laser diode
15	RSA	Analog	External resistor to GND sets swing of oscillator A
16	GND	Supply	Ground, power supply
17	RSB	Analog	External resistor to GND sets swing of oscillator B
18	IOUTA	Analog	Output current source A for laser diode
19	SELA	Digital	High: selects IOUTA, RSA, RFA Low: selects IOUTB, RSB, RFB
20	VCC	Supply	+5V power supply
21	IR	Analog	Input current, bias voltage approximately GND
22	I2	Analog	Input current, bias voltage approximately GND
23	I3	Analog	Input current, bias voltage approximately GND
24	I4	Analog	Input current, bias voltage approximately GND
Paddle	GND	Supply	Ground, negative power supply

3. Absolute Maximum Ratings

Stresses beyond those listed under “Absolute Maximum Ratings” may cause permanent damage to the device. This is a stress rating only and functional operation of the device at these or any other conditions beyond those indicated in the operational sections of this specification is not implied. Exposure to absolute maximum rating conditions for extended periods may affect device reliability.

Parameters	Symbol	Value	Unit
Supply voltage	V_{CC}	-0.5 to +6.0	V
Input voltage at any input	V_{in}	-0.5 to $V_{CC} + 0.5$	V
Voltage between LVDS inputs (E2/NE2, E3/NE3, E4/NE4)	V_{dmax}	1.7	V
Power dissipation	P_{max}	0.7 ⁽¹⁾ to 1 ⁽²⁾	W
Output voltage	V_{out}	-0.5 to $V_{CC} - 1$	V
Junction temperature	T_j	150	°C
Storage temperature	T_{stg}	-65 to +125	°C

- Notes: 1. $R_{thJA} \leq 115 \text{ K/W}$ at $T_{amb} = 70^\circ \text{C}$
 2. $R_{thJA} \leq 15 \text{ K/W}$ at $T_{amb} = 25^\circ \text{C}$

4. Thermal Resistance

Parameters	Symbol	Value	Unit
Junction ambient	R_{thJA}	125	K/W

Note: Measured with multi-layer test board (JDEC standard)

5. Recommended Operating Range

Parameters	Symbol	Value	Unit
Supply voltage	V_{CC}	4.5 to 5.5	V
Input current	$I_{I1}, I_{I2}, I_{I3}, I_{I4}$	< 1.5	mA
Voltage between LVDS inputs (E2/NE2, E3/NE3, E4/NE4)	V_d	0.5	V
External resistor to GND to set oscillator frequency	RFA, RFB	> 3	k Ω
External resistor to GND to set oscillator swing	RSA, RSB	> 100	Ω
Operating temperature range	T_{amb}	0 to +70	°C

6. Ordering Information

Extended Type Number	Package	Remarks
ATR0849-PFQG	Pb-free QFN24 (4 mm × 4 mm)	Taped and reeled

7. Package Information

Package: QFN 24 - 4x4
 Exposed pad 2.1x2.1
 (acc. JEDEC OUTLINE No. MO-220)
 Dimensions in mm

Not indicated tolerances ±0.05

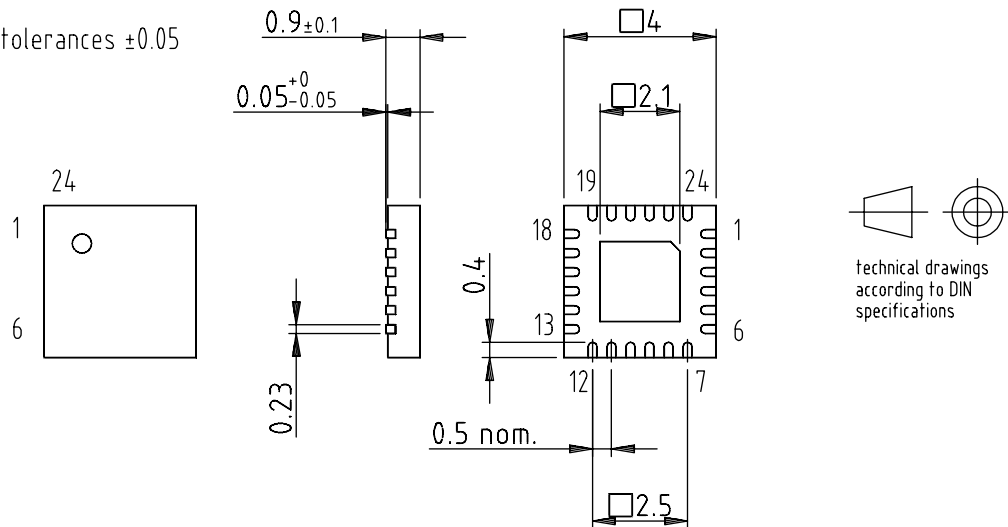

Drawing-No.: 6.543-5101.01-4

Issue: 2; 16.06.03



Atmel Corporation

2325 Orchard Parkway
San Jose, CA 95131, USA
Tel: 1(408) 441-0311
Fax: 1(408) 487-2600

Regional Headquarters

Europe

Atmel Sarl
Route des Arsenaux 41
Case Postale 80
CH-1705 Fribourg
Switzerland
Tel: (41) 26-426-5555
Fax: (41) 26-426-5500

Asia

Room 1219
Chinachem Golden Plaza
77 Mody Road Tsimshatsui
East Kowloon
Hong Kong
Tel: (852) 2721-9778
Fax: (852) 2722-1369

Japan

9F, Tonetsu Shinkawa Bldg.
1-24-8 Shinkawa
Chuo-ku, Tokyo 104-0033
Japan
Tel: (81) 3-3523-3551
Fax: (81) 3-3523-7581

Atmel Operations

Memory

2325 Orchard Parkway
San Jose, CA 95131, USA
Tel: 1(408) 441-0311
Fax: 1(408) 436-4314

Microcontrollers

2325 Orchard Parkway
San Jose, CA 95131, USA
Tel: 1(408) 441-0311
Fax: 1(408) 436-4314

La Chantrerie
BP 70602
44306 Nantes Cedex 3, France
Tel: (33) 2-40-18-18-18
Fax: (33) 2-40-18-19-60

ASIC/ASSP/Smart Cards

Zone Industrielle
13106 Rousset Cedex, France
Tel: (33) 4-42-53-60-00
Fax: (33) 4-42-53-60-01

1150 East Cheyenne Mtn. Blvd.
Colorado Springs, CO 80906, USA
Tel: 1(719) 576-3300
Fax: 1(719) 540-1759

Scottish Enterprise Technology Park
Maxwell Building
East Kilbride G75 0QR, Scotland
Tel: (44) 1355-803-000
Fax: (44) 1355-242-743

RF/Automotive

Theresienstrasse 2
Postfach 3535
74025 Heilbronn, Germany
Tel: (49) 71-31-67-0
Fax: (49) 71-31-67-2340

1150 East Cheyenne Mtn. Blvd.
Colorado Springs, CO 80906, USA
Tel: 1(719) 576-3300
Fax: 1(719) 540-1759

Biometrics/Imaging/Hi-Rel MPU/ High Speed Converters/RF Datacom

Avenue de Rochepleine
BP 123
38521 Saint-Egreve Cedex, France
Tel: (33) 4-76-58-30-00
Fax: (33) 4-76-58-34-80

Literature Requests

www.atmel.com/literature

Disclaimer: The information in this document is provided in connection with Atmel products. No license, express or implied, by estoppel or otherwise, to any intellectual property right is granted by this document or in connection with the sale of Atmel products. **EXCEPT AS SET FORTH IN ATMEL'S TERMS AND CONDITIONS OF SALE LOCATED ON ATMEL'S WEB SITE, ATMEL ASSUMES NO LIABILITY WHATSOEVER AND DISCLAIMS ANY EXPRESS, IMPLIED OR STATUTORY WARRANTY RELATING TO ITS PRODUCTS INCLUDING, BUT NOT LIMITED TO, THE IMPLIED WARRANTY OF MERCHANTABILITY, FITNESS FOR A PARTICULAR PURPOSE, OR NON-INFRINGEMENT. IN NO EVENT SHALL ATMEL BE LIABLE FOR ANY DIRECT, INDIRECT, CONSEQUENTIAL, PUNITIVE, SPECIAL OR INCIDENTAL DAMAGES (INCLUDING, WITHOUT LIMITATION, DAMAGES FOR LOSS OF PROFITS, BUSINESS INTERRUPTION, OR LOSS OF INFORMATION) ARISING OUT OF THE USE OR INABILITY TO USE THIS DOCUMENT, EVEN IF ATMEL HAS BEEN ADVISED OF THE POSSIBILITY OF SUCH DAMAGES.** Atmel makes no representations or warranties with respect to the accuracy or completeness of the contents of this document and reserves the right to make changes to specifications and product descriptions at any time without notice. Atmel does not make any commitment to update the information contained herein. Atmel's products are not intended, authorized, or warranted for use as components in applications intended to support or sustain life.

© Atmel Corporation 2005. All rights reserved. Atmel®, logo and combinations thereof, Everywhere You Are® and others, are registered trademarks or trademarks of Atmel Corporation or its subsidiaries. Other terms and product names may be trademarks of others.



Printed on recycled paper.