

Features

- ATR2740M1 is a Special Version of ATR2740 Recommended for Automotive Applications
- Highly Integrated Digital Device for DAB Receivers (Eureka 147)
- Utilizes the ARM7TDMI® Core
 - High-performance 32-bit RISC Architecture
 - High-density 16-bit Instruction Set
 - Embedded ICE (In-Circuit Emulation)
- Utilizes TeakDSPCore™
 - 16-bit Fixed-point Digital Signal Processing Core
- DAB OFDM Channel Demodulator and Decoder
 - Fully Integrated, Supports all DAB Functions and Modes
 - Full Data Rate of 1.8 Mbit Can Be Decoded
 - Automatic Mode Detection (AMD)
 - Digital AFC (Frequency Tolerance < 0.5 Hz for Mode I)
 - Digital AGC with a Wide Gain Control Range
 - Demodulation and Decoding of up to 64 UEP/EEP Sub-channels
- Audio Source Decoder (ASD) and Data Decoder (DD)
 - On-chip De-interleaver Memory for Full 1.8 Mbit/s Decoding Data Rate
 - PAD Extraction
 - Two Independent Data Packet Mode Decoder
- Integrated High-density SRAM Supporting Time and Frequency De-interleaving
- 10 Msps High-speed Low-power Pipelined ADC
 - Supports Wide IF Range of 2.048 MHz to 50 MHz
 - Complex Bandpass Filtering
 - Optional SAW Filter Equalization
- ARM7TDMI Core User Software Extension
 - Audio Player MP3 Support
- Large Variety of Interfaces
 - I²S/SPDIF, SFCO, SSO, RDI, RS-232, USART
 - Two USARTs
- Master/Slave SPI Interface
 - Two Dedicated Peripheral Data Controller (PDC) Channels
 - 8- to 16-bit Programmable Data Length
 - Four External Slave Chip Selects
- Programmable Watchdog Timer
- Power Management Controller (PMC)
 - CPU and Peripherals Can Be De-activated Individually
 - Simple But Comfortable Gearing and Clocking Unit
- 32 User Programmable I/O Lines (PIO)
- Low-power Consumption for Portable Applications (3.3V and 1.8V)
- Robust LQFP128 Package
- Very Low External Component Count



DAB Digital Processing Device

ATR2740M1

Summary

NOTE: This is a summary document. The complete document is available. For more information, please contact your local Atmel sales office.

4977CS–DAB–10/08



1. Description

www.DataSheet4U.com

The ATR2740M1 is a fully integrated processing unit which covers all DAB- (Eureka 147, ETS 300 401) related digital tasks like DAB OFDM demodulation and decoding, audio source decoding, data decoding, as well as time and frequency synchronization.

The device consists of a high-performance 32-bit RISC ARM7TDMI core, an additional TeakDSPCore, embedded memories, an analog-to-digital converter (ADC), as well as a DAB channel demodulator and decoder IP, and two independent audio source decoder engines. A large variety of interfaces, including SPI, USART and RDI, are provided.

The ATR2740M1 baseband processor is controlled by a standard ARM7TDMI core, which is a very well-known controller. This allows the designers to work with standard tools, which results in reduced development costs and very fast time to market.

The ARM7TDMI core is designed to perform the DAB receiver tasks, MMI and further user software extensions such as MP3 decoding or data decoding.

The ATR2740M1 is manufactured using Atmel's high-density CMOS technology. By combining all functions on one SoC (System-on-Chip), including a wide range of peripheral functions on a monolithic chip, the ATR2740M1 provides a highly flexible and cost-effective solution for DAB applications.

The advanced Atmel technology and the architecture of the ATR2740M1 enable maximum performance at a very low current consumption.

The wide flexibility offered by the ATR2740M1 is due to the large variety of interfaces supported. For control functions, UART and SPI are available. As data interfaces, an SSO, SFCO and RDI, as well as two audio outputs (either I²S or SPDIF), are available.

Due to the high integration of the device, the external component count is as low as only two external parts; a simple crystal and a 16-MB flash memory are required to run the full DAB function. All RAM, such as interleaving or program memory, as well as the ADC are incorporated into the device. The part works perfectly together with Atmel's DAB front-end parts.

The processing power available with the ATR2740M1 is sufficient to enable the part to decode the full DAB data rate of 1.8 Mbits. In addition, there is still unused processing power available on the ARM7TDMI controller for customer software. It is easy to run a complete MP3 player without the need to add extra hardware to the device.

A complete set of tools for hardware and software, including documentation that allows easy design-in and a fast time to market, is available on request.

Figure 1-1. Block Diagram

www.DataSheet4U.com

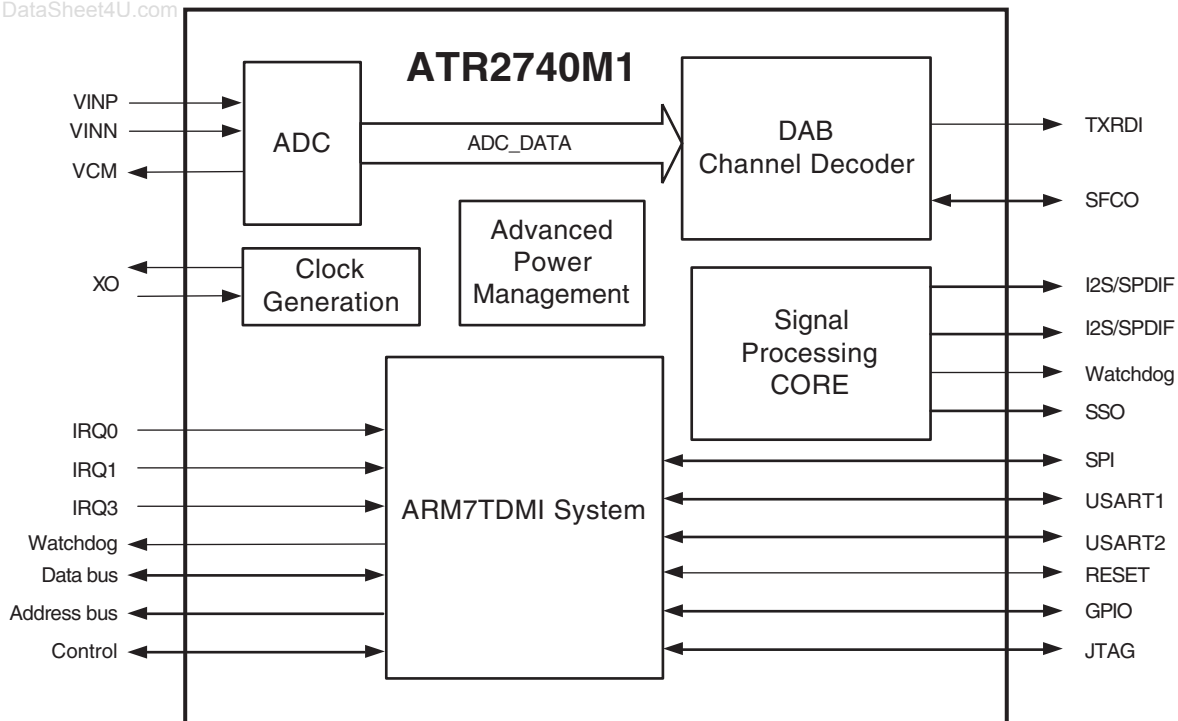

2. Absolute Maximum Ratings

Stresses beyond those listed under “Absolute Maximum Ratings” may cause permanent damage to the device. This is a stress rating only and functional operation of the device at these or any other conditions beyond those indicated in the operational sections of this specification is not implied. Exposure to absolute maximum rating conditions for extended periods may affect device reliability.

Parameters	Symbol	Min.	Max.	Unit
Operating free air temperature range for LQFP128		-40	+85	°C
Storage temperature	T_{Stg}	-60	+150	°C
DC supply voltage	VDD18	-0.3	+1.95	V
	VDD33	-0.3	+3.6	V
	AVDD	-0.3	+3.6	V
DC input voltage		-0.3	+1.95	V

Notes: 1. The part may not survive if all maximums are applied simultaneously.

Electrostatic sensitive device.
Observe precautions for handling.



3. DC Electrical Characteristics

Test conditions (if not otherwise specified): $V_{CC} = +1.8V$, $T_{amb} = +25^{\circ}C$

No.	Parameters	Test Conditions	Pin	Symbol	Min.	Typ.	Max.	Unit	Type*
1.1	DC supply voltage			VDD18	1.65	1.8	1.95	V	D
1.2	Low-level input voltage	VDD18 = 1.65 to 1.95V		V_{IL}	-0.3		$+0.3 \times VDD18$	V	D
1.3	High-level input voltage	VDD18 = 1.65 to 1.95V		V_{IH}	$+0.7 \times VDD18$		VDD18 + 0.3	V	D
1.4	Low-level output voltage	$I_{OL} = 1.5 \text{ mA}$ VDD18 = 1.65V		V_{OL}			0.4	V	A
1.5	High-level output voltage	$I_{OH} = -1.5 \text{ mA}$ VDD18 = 1.65V		V_{OH}	1.2			V	A
1.11	Crystal oscillator frequency					24.576		MHz	D
1.12	Clock duty cycle				40		60	%	D
1.14	JTAG TCK frequency			FTCK	0.02		33	MHz	D

*) Type means: A = 100% tested, B = 100% correlation tested, C = Characterized on samples, D = Design parameter

www.DataSheet4U.com
4. Electrical Characteristics on ADC/IF Input

Test conditions (if not otherwise specified): $V_{CC} = +3.3V$, $T_{amb} = +25^{\circ}C$

No.	Parameters	Test Conditions	Pin	Symbol	Min.	Typ.	Max.	Unit	Type*
2.1	ADC DC supply voltage			AVDD	3	3.3	3.6	V	D
2.2	IF frequency range			FIF	2.048		50	MHz	D

*) Type means: A = 100% tested, B = 100% correlation tested, C = Characterized on samples, D = Design parameter

5. DC Power Consumption

Test conditions (if not otherwise specified): $V_{CC} = +1.8V$, $T_{amb} = +25^{\circ}C$

Mode	Conditions	Typ.	Max.	Unit
Core Power Consumption				
DAB full	Decode of all MSC's and 1 audio sub-channel	80		mA

6. Ordering Information

Extended Type Number	Package	Remarks
ATR2740M1-RQHH	LQFP128	16 mm × 16 mm, 0.40 mm pitch, Pb-free, for automotive applications

7. Package Information LQFP128

Package: LQFP 128

(acc. JEDEC OUTLINE No. MS-026)

Dimensions in mm

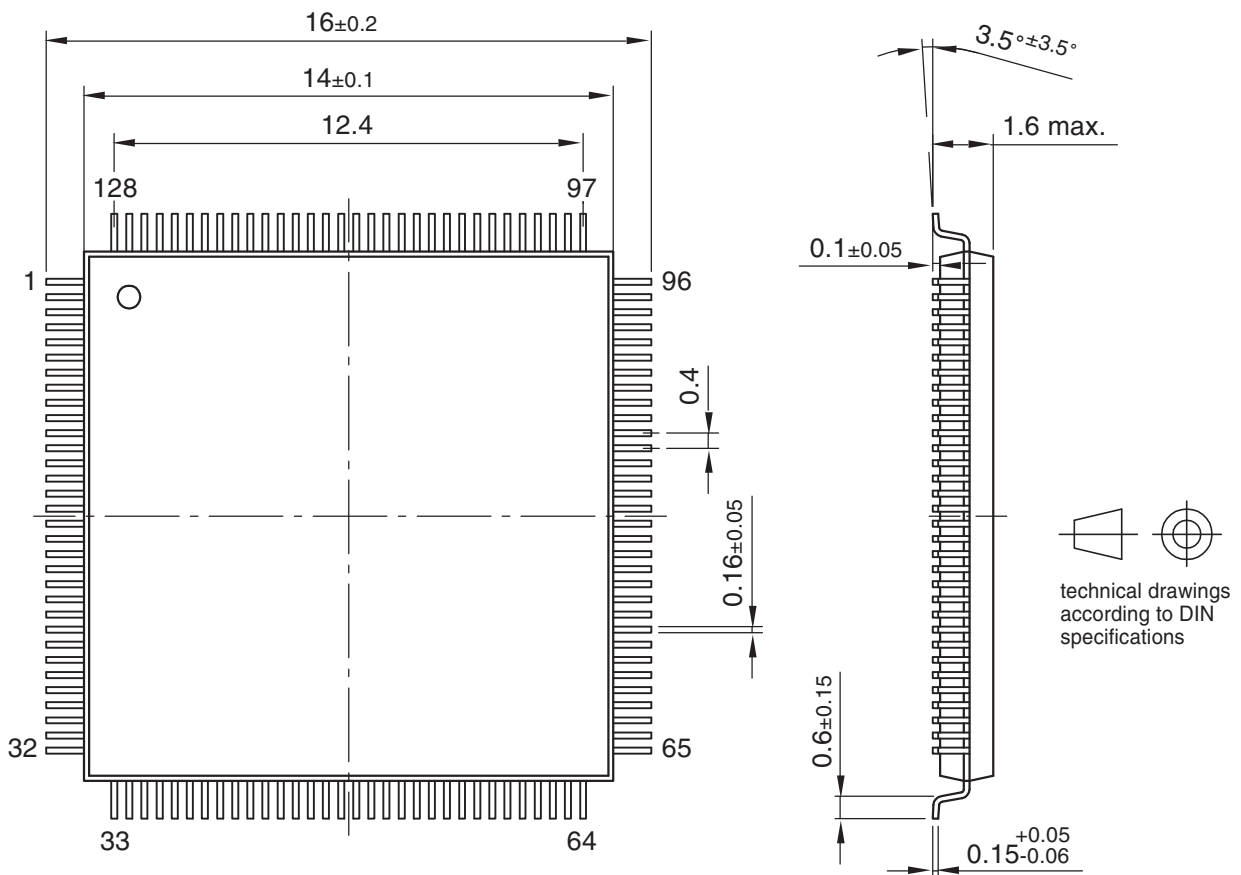

Drawing-No.: 6.543-5103.01-4

Issue: 1; 15.09.03

8. Revision History

www.DataSheet4U.com

Please note that the following page numbers referred to in this section refer to the specific revision mentioned, not to this document.

Revision No.	History
4977CS-DAB-10/08	<ul style="list-style-type: none">• USB and CAN parts deleted
4977BS-DAB-06/08	<ul style="list-style-type: none">• Put datasheet in a new template• All pages and page 1: Preliminary deleted• Page 4-5: DC El. Char. Table: some changes• Page 5: El. Char. on ADC/IF Input Table: some changes



www.DataSheet4U.com

Headquarters

Atmel Corporation
2325 Orchard Parkway
San Jose, CA 95131
USA
Tel: 1(408) 441-0311
Fax: 1(408) 487-2600

International

Atmel Asia
Room 1219
Chinachem Golden Plaza
77 Mody Road Tsimshatsui
East Kowloon
Hong Kong
Tel: (852) 2721-9778
Fax: (852) 2722-1369

Atmel Europe
Le Krebs
8, Rue Jean-Pierre Timbaud
BP 309
78054
Saint-Quentin-en-Yvelines Cedex
France
Tel: (33) 1-30-60-70-00
Fax: (33) 1-30-60-71-11

Atmel Japan
9F, Tonetsu Shinkawa Bldg.
1-24-8 Shinkawa
Chuo-ku, Tokyo 104-0033
Japan
Tel: (81) 3-3523-3551
Fax: (81) 3-3523-7581

Product Contact

Web Site
www.atmel.com

Technical Support
broadcast@atmel.com

Sales Contact
www.atmel.com/contacts

Literature Requests
www.atmel.com/literature

Disclaimer: The information in this document is provided in connection with Atmel products. No license, express or implied, by estoppel or otherwise, to any intellectual property right is granted by this document or in connection with the sale of Atmel products. **EXCEPT AS SET FORTH IN ATMEL'S TERMS AND CONDITIONS OF SALE LOCATED ON ATMEL'S WEB SITE, ATMEL ASSUMES NO LIABILITY WHATSOEVER AND DISCLAIMS ANY EXPRESS, IMPLIED OR STATUTORY WARRANTY RELATING TO ITS PRODUCTS INCLUDING, BUT NOT LIMITED TO, THE IMPLIED WARRANTY OF MERCHANTABILITY, FITNESS FOR A PARTICULAR PURPOSE, OR NON-INFRINGEMENT. IN NO EVENT SHALL ATMEL BE LIABLE FOR ANY DIRECT, INDIRECT, CONSEQUENTIAL, PUNITIVE, SPECIAL OR INCIDENTAL DAMAGES (INCLUDING, WITHOUT LIMITATION, DAMAGES FOR LOSS OF PROFITS, BUSINESS INTERRUPTION, OR LOSS OF INFORMATION) ARISING OUT OF THE USE OR INABILITY TO USE THIS DOCUMENT, EVEN IF ATMEL HAS BEEN ADVISED OF THE POSSIBILITY OF SUCH DAMAGES.** Atmel makes no representations or warranties with respect to the accuracy or completeness of the contents of this document and reserves the right to make changes to specifications and product descriptions at any time without notice. Atmel does not make any commitment to update the information contained herein. Unless specifically provided otherwise, Atmel products are not suitable for, and shall not be used in, automotive applications. Atmel's products are not intended, authorized, or warranted for use as components in applications intended to support or sustain life.

© 2008 Atmel Corporation. All rights reserved. Atmel®, Atmel logo and combinations thereof, and others, are registered trademarks or trademarks of Atmel Corporation or its subsidiaries. ARM7TDMI® is a registered trademark of ARM Ltd. TeakDSPCore™ is a trademark of DSP Group Inc. Other terms and product names may be trademarks of others.