



AU6350

USB2.0 Hub-Reader Controller

Technical Reference Manual



AU6350

USB2.0 Hub-Reader Controller



Copyright

Copyright © 1997 – 2008. Alcor Micro, Corp. All Rights Reserved. No part of this data sheet may be reproduced, transmitted, transcribed, stored in a retrieval system or translated into any language or computer language, in any form or by any means, electronic, mechanical, magnetic, optical, chemical, manual or otherwise, without prior written permission from Alcor Micro, Corp.

Trademark Acknowledgements

The company and product names mentioned in this document may be the trademarks or registered trademarks of their manufacturers.

Disclaimer

Alcor Micro, Corp. reserves the right to change this product without prior notice. Alcor Micro, Corp. makes no warranty for the use of its products and bears no responsibility for any error that appear in this document. Specifications are subject to change without prior notice.

Revision History

Date	Revision	Description
Sep 2007	0.9	Preliminary Release.
Oct 2007	0.91	Modify 3.0 Pin Assignment
Jan 2008	0.92	Modify "1.2 Features " and "4.0 Block Diagram"
Feb 2008	0.93	Update pin assignment
Apr 2008	1.00	Official release
Apr 2008	1.01	Modify "3.0 Pin Assignment – Pin14 & Pin17 information.

Contact Information:

Web site: <http://www.alcormicro.com/>

Taiwan

Alcor Micro, Corp.
4F, No 200 Kang Chien Rd., Nei Hu,
Taipei, Taiwan, R.O.C.
Phone: 886-2-8751-1984
Fax: 886-2-2659-7723

China ShenZhen Office

Rm.2407-08, Industrial Bank Building
No.4013, Shennan Road,
ShenZhen,China. 518026
Phone: (0755) 8366-9039
Fax: (0755) 8366-9101

San Jose Office

2025 Gateway Place, Suite 335
San Jose, CA 95110
USA
Phone: (408) 453-9530
Fax: (408) 453-9523

Los Angeles Office

9070 Rancho Park Court
Rancho Cucamonga, CA 91730
USA
Phone: (909) 483-8821
Fax: (909) 944-0464



<Memo>



Table of Contents

1. Introduction	1
1.1 Description.....	1
1.2 Features.....	1
2. Application Block Diagram	2
3. Pin Assignment	3
4. System Architecture and Reference Design	7
4.1 AU6350 Block Diagram	7
5. Electrical Characteristics	8
5.1 Absolute Maximum Ratings.....	8
5.2 Recommended Operating Conditions	8
5.3 General DC Characteristics	8
5.4 DC Electrical Characteristics of 3.3V I/O Cells.....	9
5.5 USB Transceiver Characteristics	9
5.6 Crystal Oscillator Circuit Setup for Characterization	12
5.7 Bus Timing/Electrical Characteristics	13
6. Mechanical Information	17
7. Abbreviations	18



List of Figures

Figure 2.1 Block Diagram.....	2
Figure 3.1 Pin Assignment Diagram	3
Figure 4.1 AU6350 Block Diagram	7
Figure 5.1 Crystal Oscillator Circuit Setup for Characterization ...	12
Figure 6.1 Mechanical Information Diagram	17

List of Tables

Table 3.1 Pin Descriptions	4
Table 5.1 Absolute Maximum Ratings	8
Table 5.2 Recommended Operating Conditions	8
Table 5.3 General DC Characteristics	8
Table 5.4 DC Electrical Characteristics of 3.3V I/O Cells	9
Table 5.5 Electrical characteristics	9
Table 5.6 Static characteristic : Digital pin	10
Table 5.7 Static characteristic : Analog I/O pins (DP/DM)	10
Table 5.8 Dynamic characteristic : Analog I/O pins (DP/DM)	11
Table 5.9 DC Electrical Characteristics	13
Table 5.10 High-speed Source Electrical Characteristics	14
Table 5.11 Full-speed Source Electrical Characteristics.....	14
Table 5.12 Low-speed Source Electrical Characteristics.....	15



1. Introduction

1.1 Description

AU6350 is a single chip integrated USB2.0 hub and multimedia card reader controller.

1.2 Features

- HUB
 - Fully compliant with USB Hub Specification version 2.0 and is also backward compatible with USB Hub specification 1.1.
 - Supports three bus-powered/self-powered downstream ports.
 - Supports automatic switching between bus-power and self-power modes.
 - Cost effective design using one transaction translator for all downstream ports.
 - Extra low power consumption.
 - On chip internal pull-up and meets USB bus power regain emend pull down resistors for all data line.
 - Built-in USB 2.0 transceiver.
 - Supports individual and gang modes of power management.
 - Built-in power switch control for over current sensing control.
 - Built-in 1.8V regulator for core logic.
 - Built-in 3.3V regulator
 - Embedded in PLL circuit for 12MHz operation precision.
 - Supports external EEPROM interface for customized PID and VID.
- Card Reader
 - USB Device Class Definition for Mass Storage, Bulk-Transport V1.0
 - Support SD spec up to ver. 2.0 (SDHC).
 - Support MMC spec up to ver. 4.2.
 - Support CF spec up to 4.1 with PIO mode 6.
 - Support xD spec up to ver. 1.2.
 - Support SMC spec up to ver. 1.4.
 - Support MS spec up to ver. 1.43.
 - Support MSPRO spec up to ver. 1.03.
 - Compatible to MSPRO-HG spec up to ver. 1.01 with 4-bit data bus.
 - Hardware DMA engine integrated for performance enhancement.
 - Work with default driver from Windows ME/2000/XP and Mac OS X; Windows 98/2000(SP1/SP2) and Mac OS 9 are supported by vendor driver from Alcor.
 - Ping-pong FIFO implementation for concurrent bus operation
 - Support multiple sectors transfer optimize performance
 - Support slot-to-slot read/write operation
 - Support Dynamic Icon Utility
 - Support LED for bus operating indication
 - Power switch integrated to reduce production BOM cost

2. Application Block Diagram

AU6350 is a single chip 3-port USB Hub-Reader controller. Its upstream port is connected to a USB Host system. The downstream ports can be used for a mouse, joystick, scanner, printer or other devices.

Figure 2.1 Block Diagram

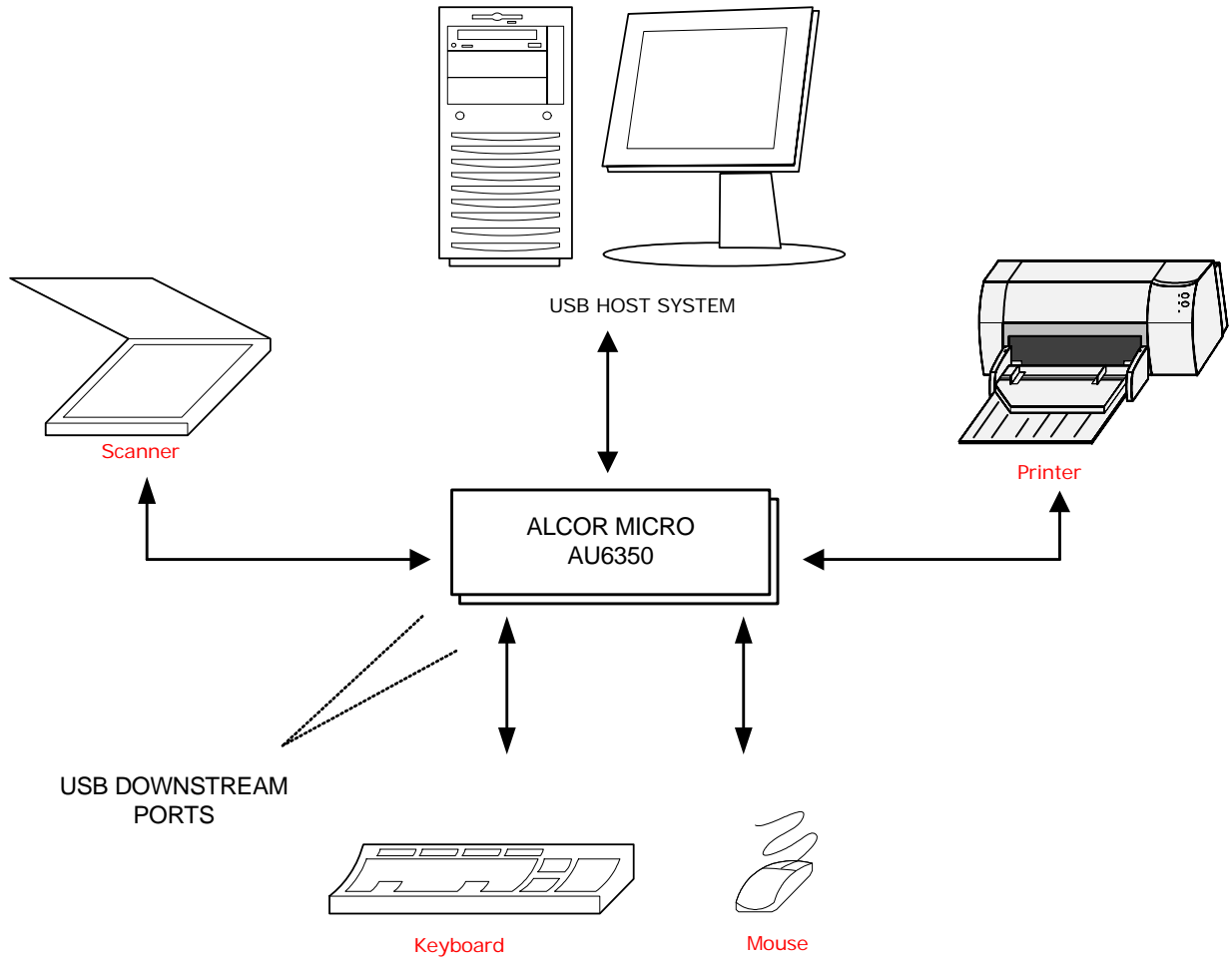

3. Pin Assignment

AU6350 is available in 80-pin LQFP package. Below diagram shows signal name of each pin and table in the following page describes each pin in detail.

Figure 3.1 Pin Assignment Diagram

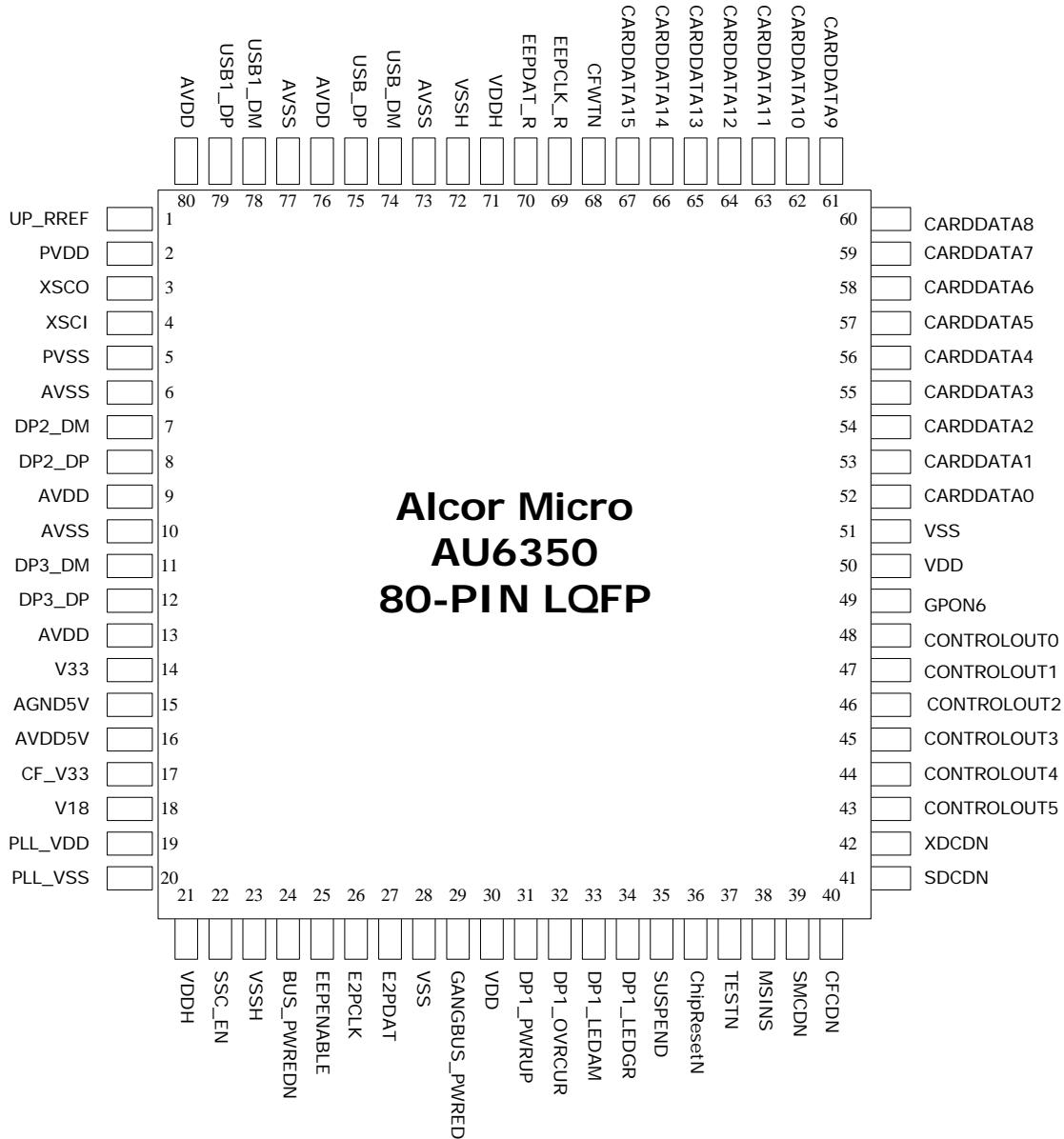



Table 3.1 Pin Descriptions

Pin #	Pin Name	I/O	Description
1	UP_RREF	UTMI	1K 1% current reference resistor
2	PVDD	Power	3.3V power input
3	XSCO	O	12MHz crystal output
4	XSCI	I	12MHz crystal input
5	PVSS	Power	Ground
6	AVSS	Power	Ground
7	DP2_DM	I/O	Port2 USB bus
8	DP2_DP	I/O	Port2 USB bus
9	AVDD	Power	3.3V power input
10	AVSS	Power	Ground
11	DP3_DM	I/O	Port3 USB bus
12	DP3_DP	I/O	Port3 USB bus
13	AVDD	Power	3.3V power input
14	V33	Power	Voltage regulator output 3.3V
15	AGND5V	Power	Ground
16	AVDD5V	Power	5V power input
17	CF_V33	Power	Card power 3.3V output
18	V18	Power	1.8V power output
19	PLL_VDD	Power	1.8V power input
20	PLL_VSS	Power	Ground
21	VDDH	Power	3.3V power input
22	SSC_EN	I	SSC enable
23	VSSH	Power	Ground
24	BUS_PWREDN	I	'1' = Self Powered '0' = Bus Powered
25	EEPENABLE	I	'1' = Use EEP contents '0' = Use internal ROM
26	E2PCLK	I/O	E2P Clock; with internal pull up resistor; open drain output
27	E2PDAT	I/O	E2P Data; with internal pull up resistor; open drain output

www.DataSheet4U.com



Pin #	Pin Name	I/O	Description			
28	VSS	Power	Ground			
29	GANGBUS_PWRED	I	'1' = Individual Power '0' = GangBus Power open collector output			
30	VDD	Power	1.8V power input			
31	DP1_PWRUP	O	Gang PowerEnable '0' = power on '1' = power off			
32	DP1_OVRCUR	I	Gang Overcurrent '0' = overcurrent '1' = not overcurrent			
33	DP1_LEDAM	O	Port1 Amber LED indicator '0' = LED on (Error condition) '1' = LED off			
34	DP1_LEDGR	O	Port1 Green LED indicator '0' = LED on (Fully operational) '1' = LED off			
35	SUSPEND	O	0' = Not Suspended '1' = Suspended			
36	ChipResetN	I	0' = Reset '1' = Run			
37	TESTN	I	1' = Normal mode '0' = Test mode			
38	MSINS	I	MS card detect, pull down when suspend otherwise pull up			
39	SMCDN	I	SMC card detect, pull down when suspend otherwise pull up			
40	CFCDN	I	CF card detect, pull down when suspend otherwise pull up			
41	SDCDN	I	SD card detect, pull down when suspend otherwise pull up			
42	XDCDN	I	XD card detect, pull down when suspend otherwise pull up			
43	CONTROLOUT5	O		CFRESETN	XDWRN	
44	CONTROLOUT4	O		CFWRN	XDRDN	
45	CONTROLOUT3	O			XDCEN	
46	CONTROLOUT2	O		CFADR2	XDALE	
47	CONTROLOUT1	O		CFADR1	XDCLE	MSCLK
48	CONTROLOUT0	O	SDCLK	CFAD0		MSBS
49	GPON6	O	Reader Card access LED			
50	VDD	Power	1.8V power input			
51	VSS	Power	Ground			

www.DataSheet4U.com



Pin #	Pin Name	I/O	Description			
52	CARDDATA0	IO	SDCMD	CFDAT0		MSDAT0
53	CARDDATA1	IO		CFDAT1	XDWPN	MSDAT1
54	CARDDATA2	IO	SDWP	CFDAT2		MSDAT2
55	CARDDATA3	IO		CFDAT3		MSDAT3
56	CARDDATA4	IO	SDDAT0	CFDAT4		MSDAT4
57	CARDDATA5	IO	SDDAT1	CFDAT5		MSDAT5
58	CARDDATA6	IO	SDDAT2	CFDAT6		MSDAT6
59	CARDDATA7	IO	SDDAT3	CFDAT7		MSDAT7
60	CARDDATA8	IO	SDDAT4	CFDAT8	XDDAT0	
61	CARDDATA9	IO	SDDAT5	CFDAT9	XDDAT1	
62	CARDDATA10	IO	SDDAT6	CFDAT10	XDDAT2	
63	CARDDATA11	IO	SDDAT7	CFDAT11	XDDAT3	
64	CARDDATA12	IO		CFDAT12	XDDAT4	
65	CARDDATA13	IO		CFDAT13	XDDAT5	
66	CARDDATA14	IO		CFDAT14	XDDAT6	
67	CARDDATA15	IO		CFDAT15	XDDAT7	
68	CFWTN	I		CFWTN		
69	EEPCLK_R	O	EEP Clock			
70	EEPDAT_R	IO	EEP Data			
71	VDDH	Power	3.3V power input			
72	VSSH	Power	Ground			
73	AVSS	Power	Ground			
74	USB_DM	I/O	Upstream port USB bus			
75	USB_DP	I/O	Upstream port USB bus			
76	AVDD	Power	3.3V power input			
77	AVSS	Power	Ground			
78	USB1_DM	I/O	Port1 USB bus			
79	USB1_DP	I/O	Port1 USB bus			
80	AVDD	Power	3.3V power input			

www.DataSheet4U.com

4. System Architecture and Reference Design

4.1 AU6350 Block Diagram

Figure 4.1 AU6350 Block Diagram

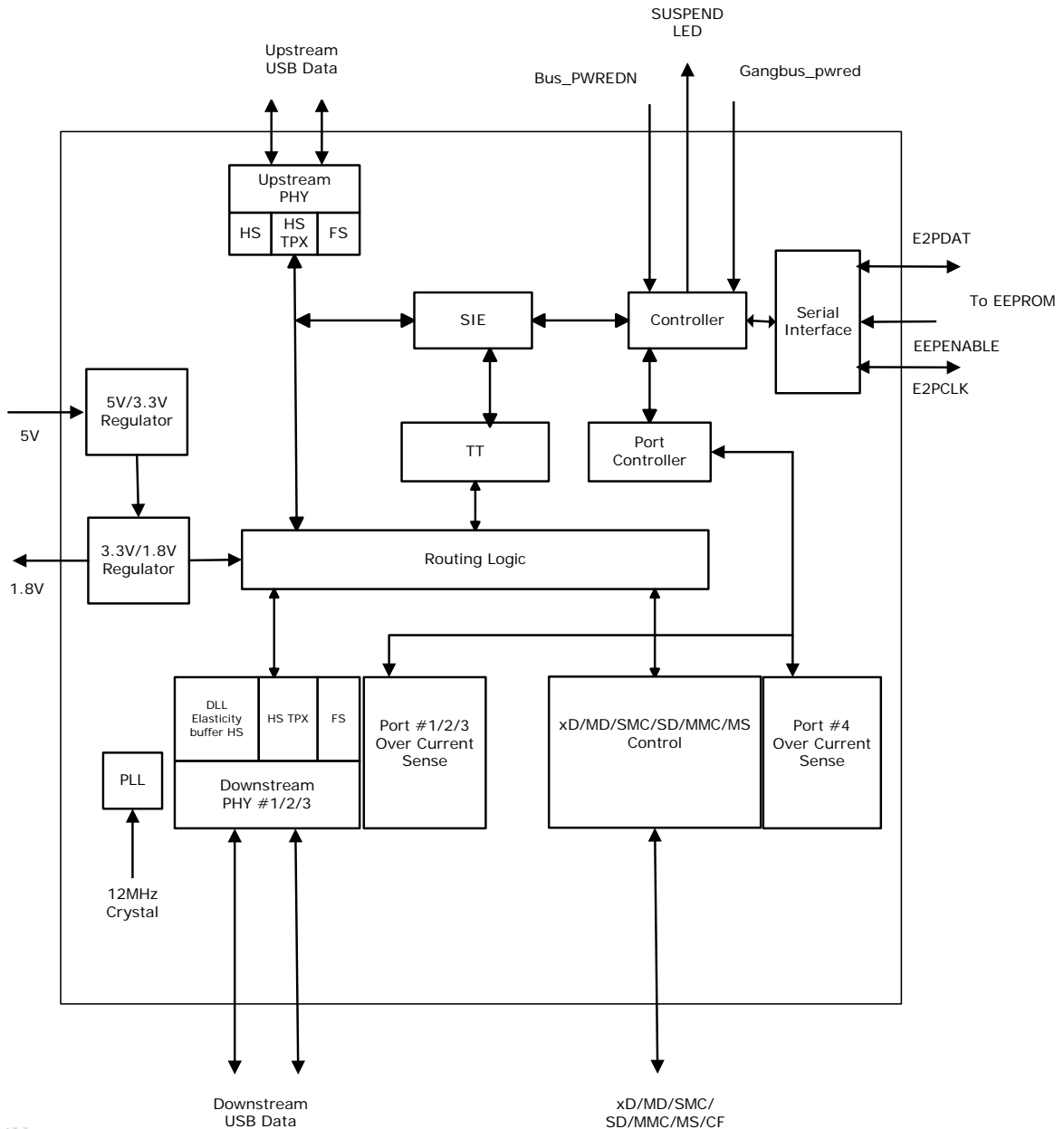

5. Electrical Characteristics

5.1 Absolute Maximum Ratings

Table 5.1 Absolute Maximum Ratings

SYMBOL	PARAMETER	RATING	UNITS
V _{DDH}	Power Supply	-0.3 to V _{DDH} +0.3	V
V _{IN}	Input Signal Voltage	-0.3 to 3.6	V
V _{OUT}	Output Signal Voltage	-0.3 to V _{DDH} +0.3	V
T _{STG}	Storage Temperature	-40 to 150	°C

5.2 Recommended Operating Conditions

Table 5.2 Recommended Operating Conditions

SYMBOL	PARAMETER	MIN	TYP	MAX	UNITS
V _{DDH}	Power Supply	3.0	3.3	3.6	V
V _{DD}	Digital Supply	1.62	1.8	1.98	V
V _{IN}	Input Signal Voltage	0	3.3	3.6	V
T _{OPR}	Operating Temperature	0		85	°C

5.3 General DC Characteristics

Table 5.3 General DC Characteristics

SYMBOL	PARAMETER	CONDITIONS	MIN	TYP	MAX	UNITS
I _{IN}	Input current	No pull-up or pull-down	-10	±1	10	μA
I _{OZ}	Tri-state leakage current		-10	±1	10	μA
C _{IN}	Input capacitance	Pad Limit		2.8		ρF
C _{OUT}	Output capacitance	Pad Limit		2.8		ρF
C _{BID}	Bi-directional buffer capacitance	Pad Limit		2.8		ρF

5.4 DC Electrical Characteristics of 3.3V I/O Cells

Table 5.4 DC Electrical Characteristics of 3.3V I/O Cells

SYMBOL	PARAMETER	CONDITIONS	Limits			UNIT
			MIN	TYP	MAX	
V _{DDH}	Power supply	3.3V I/O	3.0	3.3	3.6	V
V _{il}	Input low voltage	LVTTTL			0.8	V
V _{ih}	Input high voltage		2.0			V
V _{ol}	Output low voltage	I _{ol} =2~16mA			0.4	V
V _{oh}	Output high voltage	I _{oh} =2~16mA	2.4			V
R _{pu}	Input pull-up resistance	PU=high, PD=low	55	75	110	KΩ
R _{pd}	Input pull-down resistance	PU=low, PD=high	40	75	150	KΩ
I _{in}	Input leakage current	V _{in} = V _{DDH} or 0	-10	±1	10	μA
I _{oz}	Tri-state output leakage current		-10	±1	10	μA

5.5 USB Transceiver Characteristics

Table 5.5 Electrical characteristics

Symbol	Parameter	Conditions	Min.	Typ.	Max.	Unit
VD33	Analog supply Voltage		3.0	3.3	3.6	V
VDDU VDDA	Digital supply Voltage		1.62	1.8	1.98	V
I _{cc}	Operating supply current	High speed operating at 480 MHz			55	mA

Table 5.6 Static characteristic : Digital pin

Symbol	Parameter	Conditions	Min.	Typ.	Max.	Unit
Input levels						
V_{IL}	Low-level input voltage				0.8	V
V_{IH}	High-level input voltage		2.0			V
Output levels						
V_{OL}	Low-level output voltage				0.2	V
V_{OH}	High-level output voltage		VDDH-0.2			V

Table 5.7 Static characteristic : Analog I/O pins (DP/DM)

Symbol	Parameter	Conditions	Min.	Typ.	Max.	Unit
USB2.0 Transceiver (HS)						
Input Levels (differential receiver)						
V_{HSDIFF}	High speed differential input sensitivity	$ V_{I(DP)} - V_{I(DM)} $ measured at the connection as application circuit	300			mV
V_{HSCM}	High speed data signaling common mode voltage range		-50		500	mV
V_{HSSQ}	High speed squelch detection threshold	Squelch detected			100	mV
		No squelch detected	150			mV
V_{HSDSC}	High speed disconnection detection threshold	Disconnection detected	625			mV
		Disconnection not detected			525	mV
Output Levels						
V_{HSOI}	High speed idle level output voltage(differential)		-10		10	mV
V_{HSOL}	High speed low level output voltage(differential)		-10		10	mV
V_{HSOH}	High speed high level output voltage(differential)		-360		400	mV
V_{CHIRPJ}	Chirp-J output voltage (differential)		700		1100	mV
V_{CHIRPK}	Chirp-K output voltage (differential)		-900		-500	mV
Resistance						
R_{DRV}	Driver output impedance	Equivalent resistance used as internal chip only	3	6	9	Ω



		Overall resistance including external resistor	40.5	45	49.5	
Termination						
V_{TERM}	Termination voltage for pull-up resistor on pin RPU		3.0		3.6	V
USB1.1 Transceiver (FS/LS)						
Input Levels (differential receiver)						
V_{DI}	Differential input sensitivity	$ V_{I(DP)} - V_{I(DM)} $	0.2			V
V_{CM}	Differential common mode voltage		0.8		2.5	V
Input Levels (single-ended receivers)						
V_{SE}	Single ended receiver threshold		0.8		2.0	V
Output levels						
V_{OL}	Low-level output voltage		0		0.3	V
V_{OH}	High-level output voltage		2.8		3.6	V

Table 5.8 Dynamic characteristic : Analog I/O pins (DP/DM)

Symbol	Parameter	Conditions	Min.	Typ.	Max.	Unit
Driver Characteristics						
High-Speed Mode						
t_{HSR}	High-speed differential rise time		500			ps
t_{HSF}	High-speed differential fall time		500			ps
Full-Speed Mode						
t_{FR}	Rise time	CL=50pF ; 10 to 90% of $ V_{OH}-V_{OL} $;	4		20	ns
t_{FF}	Fall time	CL=50pF ; 90 to 10% of $ V_{OH}-V_{OL} $;	4		20	ns
t_{FRMA}	Differential rise/fall time matching (t_{FR} / t_{FF})	Excluding the first transition from idle mode	90		110	%
V_{CRS}	Output signal crossover voltage	Excluding the first transition from idle mode	1.3		2.0	V
Low-Speed Mode						
t_{LR}	Rise time	CL=200pF-600pF ; 10 to 90% of $ V_{OH}-V_{OL} $;	75		300	ns

www.DataSheet4U.com

t_{LF}	Fall time	$CL=200pF-600pF$; 90 to 10% of $ V_{OH}-V_{OL} $;	75		300	ns
t_{LRMA}	Differential rise/fall time matching (t_{LR} / t_{LF})	Excluding the first transition from idle mode	80		125	%
V_{CRS}	Output signal crossover voltage	Excluding the first transition from idle mode	1.3		2.0	V
V_{OH}	High-level output voltage		2.8		3.6	V

5.6 Crystal Oscillator Circuit Setup for Characterization

The following setup was used to measure the open loop voltage gain for crystal oscillator circuits. The feedback resistor serves to bias the circuit at its quiescent operating point and the AC coupling capacitor, C_s , is much larger than C_1 and C_2 .

Figure 5.1 Crystal Oscillator Circuit Setup for Characterization

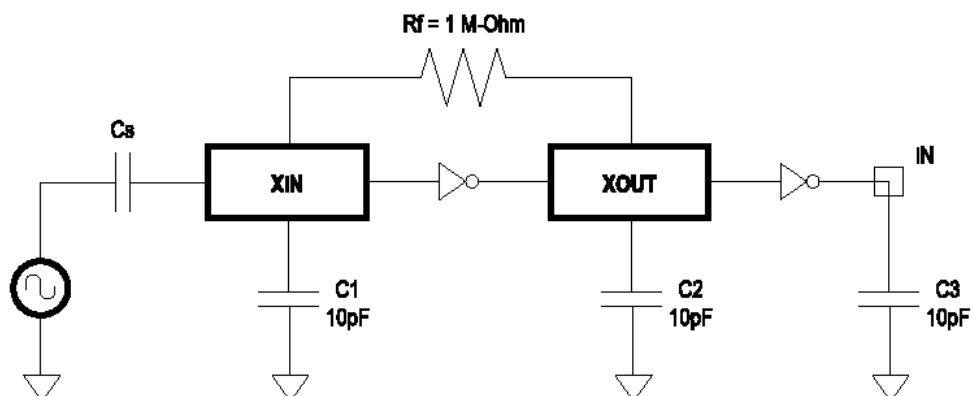



5.7 Bus Timing/Electrical Characteristics

Table 5.9 DC Electrical Characteristics

Input Levels for Low-/Full –speed:

SYMBOL	PARAMETER	LIMITS		UNIT
		MIN	MAX	
V _{IH}	High (Driven)	2.0		V
V _{IHZ}	High (floating)	2.7	3.6	V
V _{IL}	Low		0.8	V
V _{DI}	Differential Input Sensitivity	0.2		V
V _{CM}	Differential Common Mode Range	0.8	2.5	V

Input Levels for High –speed:

SYMBOL	PARAMETER	LIMITS		UNIT
		MIN	MAX	
V _{HHSSQ}	High-speed squelch detection threshold (differential signal amplitude)	100	150	mV
V _{HSDSC}	High speed disconnect detection threshold (differential signal amplitude)	525	625	mV

Output Levels for Low-/Full-speed:

SYMBOL	PARAMETER	LIMITS		UNIT
		MIN	MAX	
V _{OL}	Low	0.0	0.3	V
V _{OH}	High (driven)	2.8	3.6	V
V _{OSE1}	SE1	0.8		V
V _{CRS}	Output Signal Crossover Voltage	1.3	2.0	V

Output Levels for High –speed:

SYMBOL	PARAMETER	LIMITS		UNIT
		MIN	MAX	
V _{HSOI}	High-speed idle level	-10	10	mV
V _{HSOH}	High-speed data signaling high	360	440	mV
V _{HSOL}	High-speed data signaling low	-10	10	mV
V _{CHIRPJ}	Chirp J level (differential voltage)	700	1100	mV
V _{CHIRPK}	Chirp K level (differential voltage)	-900	-500	mV

www.DataSheet4U.com

Terminations:

SYMBOL	PARAMETER	LIMITS		UNIT
		MIN	MAX	
R_{PU}	Bus Pull-up Resistor on Upstream Facing Port	1.425	1.575	$k\Omega$
R_{PD}	Bus Pull-down Resistor on Upstream Facing Port	14.25	15.75	$k\Omega$
Z_{INP}	Input impedance exclusive of pull-up/pull-down (for low-/full-speed)	300		$k\Omega$
V_{TERM}	Termination voltage for upstream facing port pull-up (R_{PU})	3.0	3.6	V

Terminations in High-speed:

SYMBOL	PARAMETER	LIMITS		UNIT
		MIN	MAX	
V_{HSTERM}	Termination voltage in high-speed	-10	10	mV

Table 5.10 High-speed Source Electrical Characteristics

Driver Characteristics:

SYMBOL	PARAMETER	LIMITS		UNIT
		MIN	MAX	
T_{HSR}	Rise Time (10%-90%)	500		ps
T_{HSF}	Fall Time (10%-90%)	500		ps
Z_{HSDRV}	Driver Output Resistance (which also serves as high-speed termination)	40.5	49.5	Ω

Clock Timings:

SYMBOL	PARAMETER	LIMITS		UNIT
		MIN	MAX	
T_{HSDRAT}	High-speed Data Rate	479.76	480.24	Mb/s
T_{HSFRAM}	Micorframe Interval	124.9375	125.0625	μs
T_{HSRFI}	Consecutive Microframe Interval Difference		4 high-speed bit times	

Table 5.11 Full-speed Source Electrical Characteristics

Driver Characteristics:

SYMBOL	PARAMETER	LIMITS		UNIT
		MIN	MAX	
T_{FR}	Rise Time	4	20	ns
T_{FF}	Fall Time	4	20	ns
T_{FRFM}	Differential Rise and Fall Time Matching	90	111.11	%
Z_{ZRV}	Driver Output Resistance for driver which is not high-speed capable	28	44	Ω



Clock Timings:

SYMBOL	PARAMETER	LIMITS		UNIT
		MIN	MAX	
$T_{FDRATHS}$	Full-speed Data Rate for hubs and devices which are high-speed capable	11.994	12.006	Mb/s
T_{FDRATE}	Full-speed Data Rate for devices which are not high-speed capable	11.970	12.030	Mb/s
T_{FRAME}	Frame interval	0.9995	1.0005	Ms
T_{RFI}	Consecutive Frame Interval Jitter		42	ns

Full-speed Data Timings:

SYMBOL	PARAMETER	LIMITS		UNIT
		MIN	MAX	
T_{DJ1}	Source Jitter Total(including frequency tolerance): To Next Transition For Paired Transitions	-3.5	-3.5	ns
T_{DJ2}		-4	-4	ns
T_{FDEOP}	Source Jitter for Differential Transition to SE0 Transition	-2	5	ns
T_{JR1}	Receiver Jitter: To Next Transition For Paired Transitions	-18.5	-18.5	ns
T_{JR2}		-9	-9	ns
T_{FEPPT}	Source SE0 interval of EOP	160	175	ns
T_{FEOPR}	Receiver SE0 interval of EOP	82		ns
T_{FST}	Width of SE0 interval during differential transition		14	ns

Table 5.12 Low-speed Source Electrical Characteristics

Driver Characteristics:

SYMBOL	PARAMETER	LIMITS		UNIT
		MIN	MAX	
T_{LR}	Rise Time	75	300	ns
T_{LF}	Fall Time	75	300	ns
T_{LRFM}	Differential Rise and Fall Time Matching	80	125	%
C_{LINUA}	Upstream Facing Port (w/cable, low-speed only)	200	450	pF

Clock Timings:

SYMBOL	PARAMETER	LIMITS		UNIT
		MIN	MAX	
$T_{LDRATHS}$	Low-speed Data Rate for hubs and devices which are high-speed capable	1.49925	1.50075	Mb/s
T_{LDRATE}	Low-speed Data Rate for devices which are not high-speed capable	1.4775	1.5225	Mb/s

www.DataSheet4U.com



Low-speed Data Timings:

SYMBOL	PARAMETER	LIMITS		UNIT
		MIN	MAX	
T _{UDJ1} T _{UDJ2}	Upstream facing port source Jitter Total(including frequency tolerance): To Next Transition For Paired Transitions	-95 -150	95 150	ns ns
T _{LDEOP}	Upstream facing port source Jitter for Differential Transition to SE0 Transition	-40	100	ns
T _{DJR1} T _{DJR2}	Upstream facing port differential Receiver Jitter: To Next Transition For Paired Transitions	-75 -45	75 45	ns ns
T _{DDJ1} T _{DDJ2}	Upstream facing port differential Receiver Jitter: To Next Transition For Paired Transitions	-25 -14	25 14	ns ns
T _{UJR1} T _{UJR2}	Downstream facing port Differential Receiver Jitter: To Next Transition For Paired Transitions	-152 -200	152 200	ns ns
T _{LEOPT}	Source SE0 interval of EOP	1.25	1.50	μs
T _{LEOPR}	Receiver SE0 interval of EOP	670		ns
T _{LST}	Width of SE0 interval during differential transition		210	ns

6. Mechanical Information

Figure 6.1 Mechanical Information Diagram

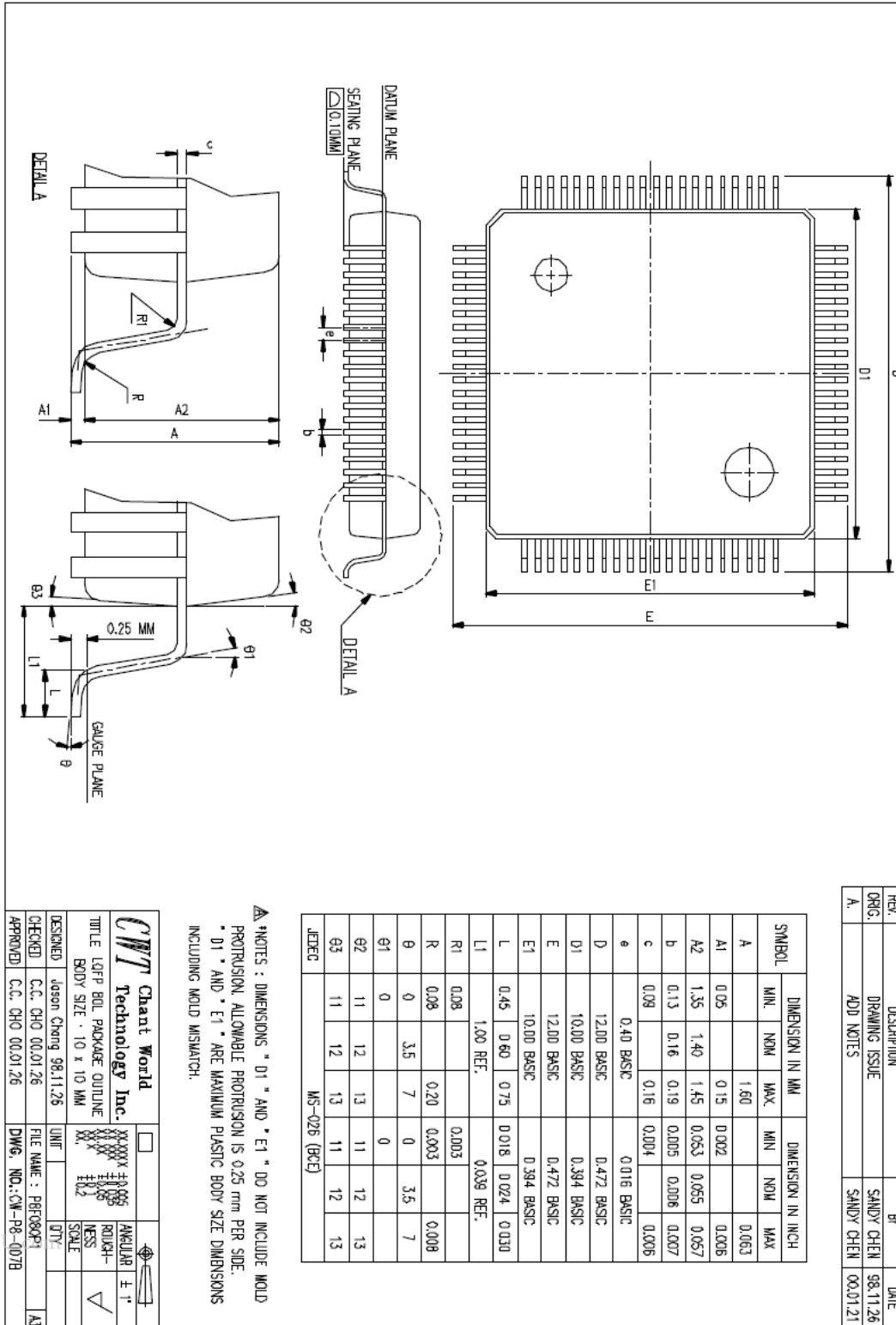



7. Abbreviations

In this chapter some of the terms and abbreviations used throughout the technical reference manual are listed as follows.

SIE	Serial Interface Engine
UTMI	USB Transceiver Macrocell Interface
CF	Compact Flash
MD	Micro Drive
SMC	SmartMedia Card
MS	Memory Stick
SD	Secure Digital
MMC	Multimedia Card

About Alcor Micro, Corp.

Alcor Micro, Corp. designs, develops and markets highly integrated and advanced peripheral semiconductor, and software driver solutions for the personal computer and consumer electronics markets worldwide. We specialize in USB solutions and focus on emerging technology such as USB and IEEE 1394. The company offers a range of semiconductors including controllers for USB hub, integrated keyboard/USB hub and USB Flash memory card reader...etc. Alcor Micro, Corp. is based in Taipei, Taiwan, with sales offices in Taipei, Japan, Korea and California. Alcor Micro is distinguished by its ability to provide innovative solutions for spec-driven products. Innovations like single chip solutions for traditional multiple chip products and on-board voltage regulators enable the company to provide cost-efficiency solutions for the computer peripheral device OEM customers worldwide.