



AU6475

**USB2.0 Multi-LUN Flash Card Reader
Controller**

Technical Reference Manual



AU6475

**USB2.0 Multi-LUN Flash Card Reader
Controller**



Copyright

Copyright © 1997 - 2007. Alcor Micro, Corp. All Rights Reserved. No part of this data sheet may be reproduced, transmitted, transcribed, stored in a retrieval system or translated into any language or computer language, in any form or by any means, electronic, mechanical, magnetic, optical, chemical, manual or otherwise, without prior written permission from Alcor Micro, Corp.

Trademark Acknowledgements

The company and product names mentioned in this document may be the trademarks or registered trademarks of their manufacturers.

Disclaimer

Alcor Micro, Corp. reserves the right to change this product without prior notice. Alcor Micro, Corp. makes no warranty for the use of its products and bears no responsibility for any error that appear in this document. Specifications are subject to change without prior notice.

Revision History

Date	Revision	Description
Oct 2007	1.00W	Official Release.
Dec 2007	1.01W	Modify "1.2 Features" and "Figure 4.1 AU6475 Block Diagram"

Contact Information:

Web site: <http://www.alcormicro.com/>

Taiwan

Alcor Micro, Corp.
4F, No 200 Kang Chien Rd., Nei Hu,
Taipei, Taiwan, R.O.C.
Phone: 886-2-8751-1984
Fax: 886-2-2659-7723

China ShenZhen Office

Rm.2407-08, Industrial Bank Building
No.4013, Shennan Road,
ShenZhen,China. 518026
Phone: (0755) 8366-9039
Fax: (0755) 8366-9101

Santa Clara Office

2901 Tasman Drive, Suite 206
Santa Clara, CA 95054
USA
Phone: (408) 845-9300
Fax: (408) 845-9086

Los Angeles Office

9070 Rancho Park Court
Rancho Cucamonga, CA 91730
USA
Phone: (909) 483-8821
Fax: (909) 944-0464



<Memo>



Table of Contents

1. Introduction	1
1.1 Description.....	1
1.2 Features.....	1
2. Application Block Diagram	2
3. Pin Assignment	3
4. System Architecture and Reference Design	7
4.1 AU6475 Block Diagram	7
5. Electrical Characteristics	8
5.1 Absolute Maximum Ratings.....	8
5.2 Recommended Operating Conditions	8
5.3 General DC Characteristics	8
5.4 DC Electrical Characteristics of 3.3V I/O Cells.....	9
5.5 USB Transceiver Characteristics	9
5.6 Power Switch Feature	12
6. Mechanical Information	13
7. Abbreviations	14



List of Figures

Figure 2.1 Block Diagram.....	2
Figure 3.1 AU6475 Pin Assignment Diagram	3
Figure 4.1 AU6475 Block Diagram	7
Figure 5.1 Built-in card power switch I-V curve	12
Figure 5.2 Card Detect Power-in Timing.....	12
Figure 6.1 Mechanical Information Diagram	13

List of Tables

Table 3.1 AU6475 Pin Descriptions.....	4
Table 5.1 Absolute Maximum Ratings	8
Table 5.2 Recommended Operating Conditions	8
Table 5.3 General DC Characteristics	8
Table 5.4 DC Electrical Characteristics of 3.3V I/O Cells	9
Table 5.5 Electrical characteristics	9
Table 5.6 Static characteristic : Digital pin	10
Table 5.7 Static characteristic : Analog I/O pins (DP/DM)	10
Table 5.8 Dynamic characteristic : Analog I/O pins (DP/DM)	11



1. Introduction

1.1 Description

The AU6475 is a single chip integrated USB 2.0 multimedia card reader controller that enables PC/DVD/Printer to read/write various type of flash media cards. Flash media cards such as CF, SMC, XD, SD, MMC, Memory Stick are widely used in digital camera, cell phone, PDA and MP3 player to store digital photos and compressed music.

Performance of AU6475 is maximized by implementing the latest and fastest card specification available from the industry.

Especially, AU6475 is designed with the high performance characteristic in flash card I/O speed. Users can easy and fast transfer the digital content among the different flash card.

1.2 Features

- Support USB V2.0 specification and USB Device Class Definition for Mass Storage, Bulk-Transport V1.0
- Support CF/MD/SD/MMC/MS/MS_Pro/MS_Duo/xD/SMC compatible flash card
- Support SD1.1/SD2.0
- Support MMC4.1. MMC4.2. with 4-bit data bus.
- Support CF4.1 with True IDE mode 6.
- Compliant to xD 1.2 spec.
- Support MS 1.43, MSPRO 1.02, MSPRO-HG 1.01 with 4-bit data bus.
- Hardware DMA engine integrated for performance enhancement.
- Work with default driver from Windows ME/2000/XP/Vista and Mac OS X; Windows 98/2000(SP1/SP2) and Mac OS 9 are supported by vendor driver from Alcor.
- Ping-pong FIFO implementation for concurrent bus operation
- Support multiple sectors transfer optimize performance
- Support slot-to-slot read/write operation
- Support Dynamic Icon Utility
- Support LED for bus operating indication
- Power switch integrated to reduce production BOM cost
- 30MHz 8051 CPU
- 5→3.3 and 3.3→1.8V regulators built in
- Runs at 12MHz crystal
- Available in 80-pin LQFP package

2. Application Block Diagram

Following application diagram demonstrates a typical card reader using the AU6475 chip. By connecting the card reader to a desktop or notebook PC through USB bus, the AU6475 becomes a bus-powered, high speed USB card reader, which can be used as a bridge for data transfer between Desktop PC and Notebook PC.

Figure 2.1 Block Diagram

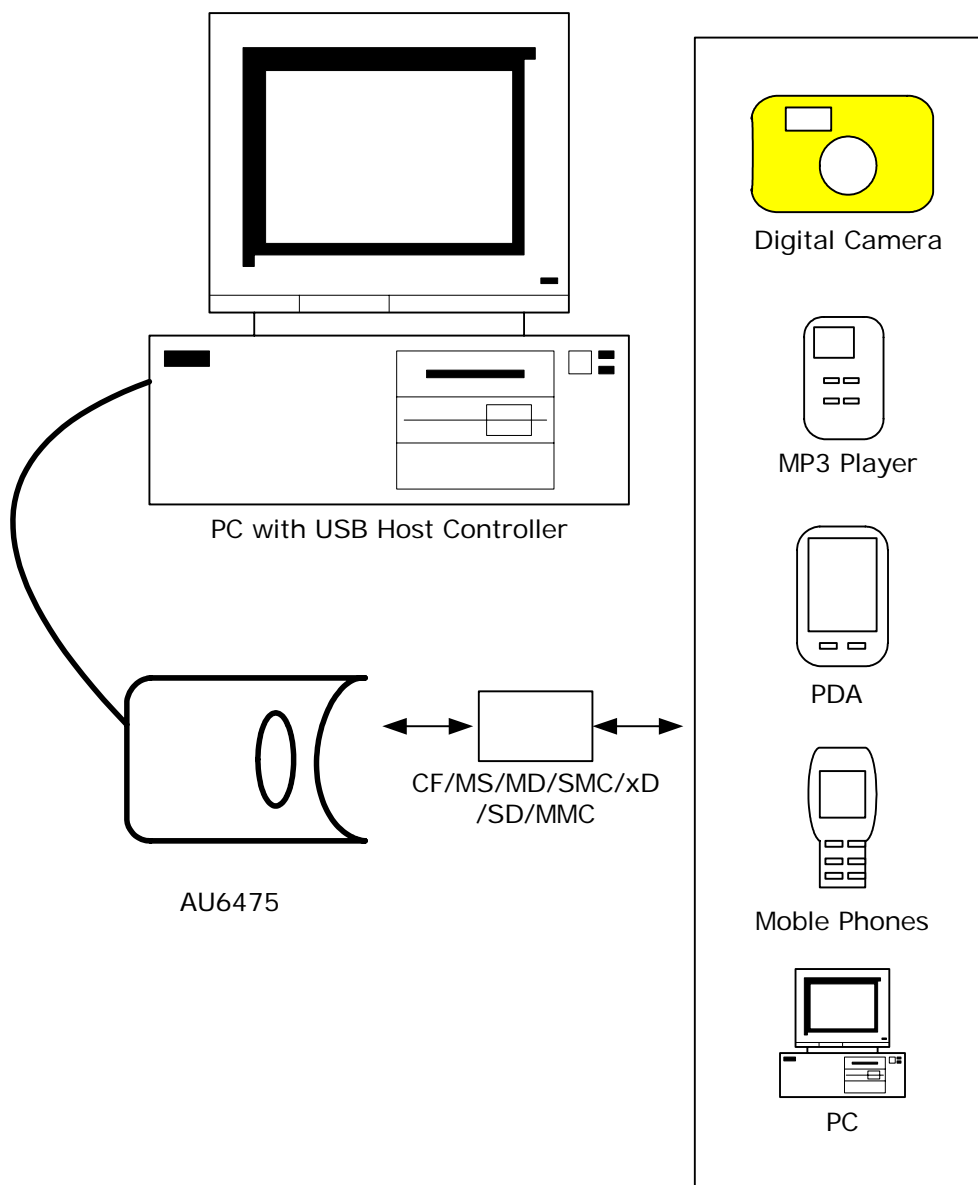

3. Pin Assignment

AU6475 is available in 80-pin LQFP package. Below diagram shows signal name of each pin and table in the following page describes each pin in detail.

Figure 3.1 AU6475 Pin Assignment Diagram

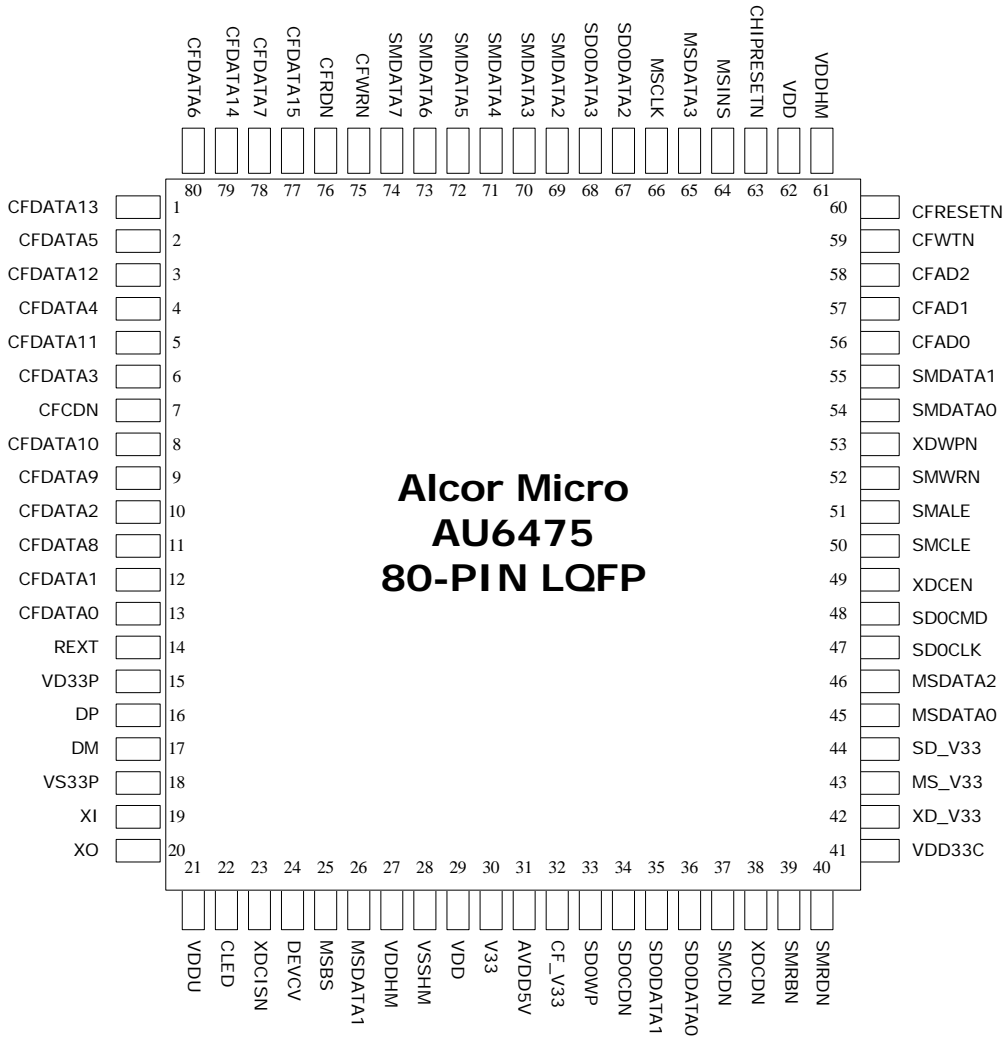



Table 3.1 AU6475 Pin Descriptions

Pin #	Pin Name	I/O	Description
1	CFDATA13	I/O	CF Data13
2	CFDATA5	I/O	CF Data5
3	CFDATA12	I/O	CF Data12
4	CFDATA4	I/O	CF Data4
5	CFDATA11	I/O	CF Data11
6	CFDATA3	I/O	CF Data3
7	CFCDN	I	CF Card Detect
8	CFDATA10	I/O	CF Data10
9	CFDATA9	I/O	CF Data9
10	CFDATA2	I/O	CF Data2
11	CFDATA8	I/O	CF Data8
12	CFDATA1	I/O	CF Data1
13	CFDATA0	I/O	CF Data0
14	REXT	I/O	External Resistor 330 to Ground
15	VD33P	PWR	3.3V Power Source for UTMI
16	DP	I/O	DP
17	DM	I/O	DM
18	VS33P	GND	Power Ground
19	XI	I	12MHz Crystal Input
20	XO	O	12MHz Crystal Output
21	VDDU	PWR	1.8V Power Source for UTMI
22	CLED	O	Card access LED. No card : '1' Any card inserted : '0' Any card access : toggle between '1' & '0'
23	XDCISN	I	Disable xD CIS checking '0' for enable xD CIS checking. '1' for disable xD CIS checking. [Default] '0'
24	DEVCV	I	USB current value. ("1":high power to pass USB-IF; "0":low power for bus-power hub compatibility)
25	MSBS	O	MS BS
26	MSDATA1	I/O	MS Data1
27	VDDHM	PWR	IO Power 3.3V In
28	VSSHM	GND	3.3V ground for IO pad
29	VDD	PWR	Core Power for 1.8V In
30	V33	PWR	Band-gap 3.3V out
31	AVDD5V	PWR	5V power from Vbus
32	CF_V33	PWR	CF power 3.3V out
33	SD0WP	I	SD0 Write Protect



Pin #	Pin Name	I/O	Description
34	SD0CDN	I	SD0 Card Detect
35	SD0DATA1	I/O	SD Data1
36	SD0DATA0	I/O	SD Data0
37	SMCDN	I	SMC Card Detect
38	XDCDN	I	xD Card Detect
39	SMRBN	I	xD/SMC RBN
40	SMRDN	O	xD/SMC RDN
41	VDD33C	PWR	Card power 3.3V input
42	XD_V33	PWR	XD power 3.3V output
43	MS_V33	PWR	MS power 3.3V output
44	SD_V33	PWR	SD power 3.3V output
45	MSDATA0	I/O	MS Data0
46	MSDATA2	I/O	MS Data2
47	SD0CLK	O	SD CLK
48	SD0CMD	I/O	SD CMD
49	XDCEN	O	xD CEN
50	SMCLE	O	xD/SMC CLE
51	SMALE	O	xD/SMC ALE
52	SMWRN	O	xD/SMC WRN
53	XDWPN	I/O	xD/SMC WPN
54	SMDATA0	I/O	xD/SMC Data0
55	SMDATA1	I/O	xD/SMC Data1
56	CFAD0	O	CF Adress0
57	CFAD1	O	CF Adress1
58	CFAD2	O	CF Adress2
59	CFWTN	I	CF WTN
60	CFRESETN	O	CF Reset
61	VDDHM		IO Power 3.3V In
62	VDD	PWR	Core Power 1.8V In
63	CHIPRESETN	I	Chip Exteranl Reset:Low active
64	MSINS	I	MS Card Detect '0': Detected '1': Undetected
65	MSDATA3	I/O	MS Data3
66	MSCLK	O	MS CLK
67	SD0DATA2	I/O	SD Data2
68	SD0DATA3	I/O	SD Data3
69	SMDATA2	I/O	xD/SMC Data2
70	SMDATA3	I/O	xD/SMC Data3
71	SMDATA4	I/O	xD/SMC Data4



	Pin Name	I/O	Description
72	SMDATA5	I/O	xD/SMC Data5
73	SMDATA6	I/O	xD/SMC Data6
74	SMDATA7	I/O	xD/SMC Data7
75	CFWRN	O	CF WRN
76	CFRDN	O	CF RDN
77	CFDATA15	I/O	CF Data15
78	CFDATA7	I/O	CF Data7
79	CFDATA14	I/O	CF Data14
80	CFDATA6	I/O	CF Data6

4. System Architecture and Reference Design

4.1 AU6475 Block Diagram

Figure 4.1 AU6475 Block Diagram

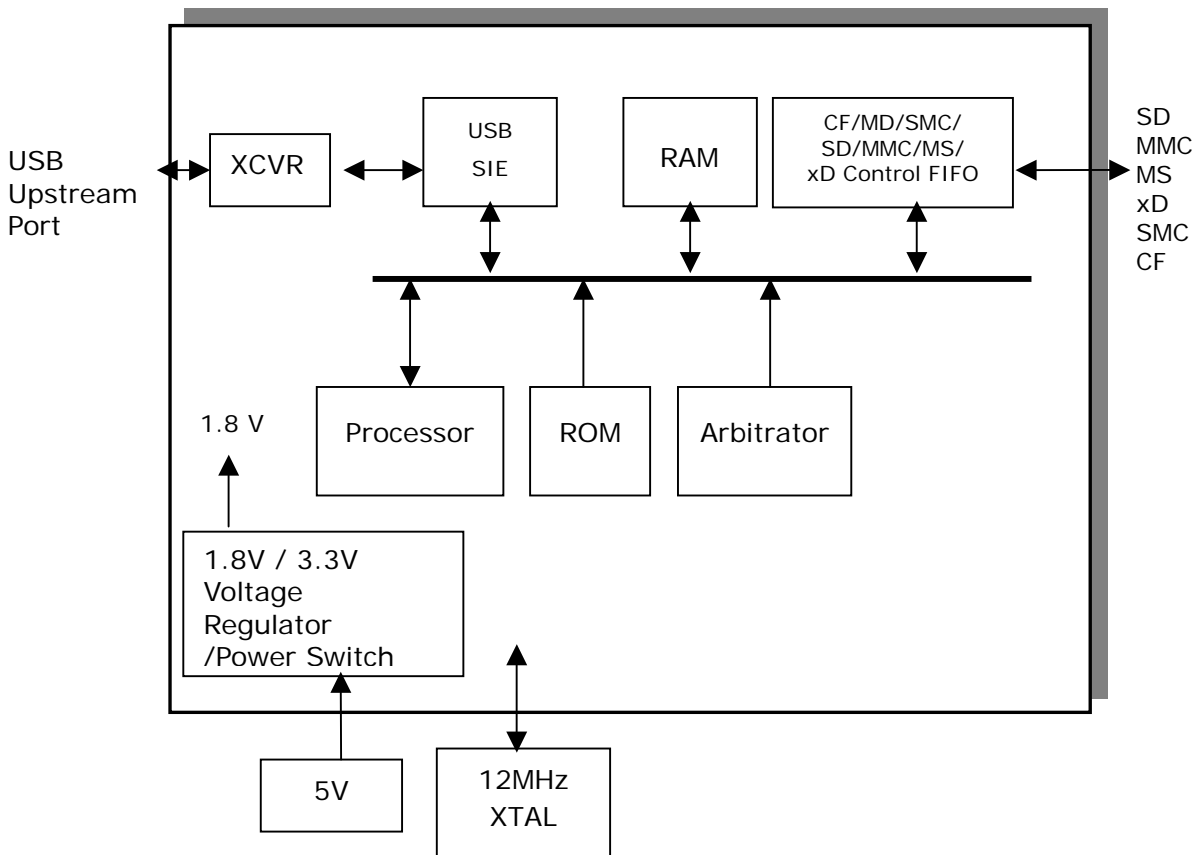

5. Electrical Characteristics

5.1 Absolute Maximum Ratings

Table 5.1 Absolute Maximum Ratings

SYMBOL	PARAMETER	RATING	UNITS
V _{5IN}	Power Supply	-0.3 to 5.25	V
V _{DDH}	Power Supply	-0.3 to 3.6	V
V _{IN}	Input Signal Voltage	-0.3 to V _{DDH} +0.3	V
T _{STG}	Storage Temperature	-40 to 150	°C

5.2 Recommended Operating Conditions

Table 5.2 Recommended Operating Conditions

SYMBOL	PARAMETER	MIN	TYP	MAX	UNITS
V _{5IN}	Power Supply	4.75	5.0	5.25	V
V _{DDH}	Power Supply	3.0	3.3	3.6	V
V _{DD} V ₁₈	Digital Supply	1.62	1.8	1.98	V
V _{IN}	Input Signal Voltage	0	3.3	3.6	V
T _{OPR}	Operating Temperature	0		85	°C

5.3 General DC Characteristics

Table 5.3 General DC Characteristics

SYMBOL	PARAMETER	CONDITIONS	MIN	TYP	MAX	UNITS
I _{IN}	Input current	No pull-up or pull-down	-10	±1	10	μA
I _{OZ}	Tri-state leakage current		-10	±1	10	μA
C _{IN}	Input capacitance	Pad Limit		2.8		ρF
C _{OUT}	Output capacitance	Pad Limit		2.8		ρF
C _{BID}	Bi-directional buffer capacitance	Pad Limit		2.8		ρF

5.4 DC Electrical Characteristics of 3.3V I/O Cells

Table 5.4 DC Electrical Characteristics of 3.3V I/O Cells

SYMBOL	PARAMETER	CONDITIONS	Limits			UNIT
			MIN	TYP	MAX	
V_{DDH}	Power supply	3.3V I/O	3.0	3.3	3.6	V
V_{il}	Input low voltage	LVTTTL			0.8	V
V_{ih}	Input high voltage		2.0			V
V_{ol}	Output low voltage	$ I_{ol} = 2\sim 16\text{mA}$			0.4	V
V_{oh}	Output high voltage	$ I_{oh} = 2\sim 16\text{mA}$	2.4			V
R_{pu}	Input pull-up resistance	PU=high, PD=low	55	75	110	$K\Omega$
R_{pd}	Input pull-down resistance	PU=low, PD=high	40	75	150	$K\Omega$
I_{in}	Input leakage current	$V_{in} = V_{DDH}$ or 0	-10	± 1	10	μA
I_{oz}	Tri-state output leakage current		-10	± 1	10	μA

5.5 USB Transceiver Characteristics

Table 5.5 Electrical characteristics

Symbol	Parameter	Conditions	Min.	Typ.	Max.	Unit
VD33P	Analog supply Voltage		3.0	3.3	3.6	V
VDD V18	Digital supply Voltage		1.62	1.8	1.98	V
I_{cc}	Operating supply current	High speed operating at 480 MHz			55	mA

Table 5.6 Static characteristic : Digital pin

Symbol	Parameter	Conditions	Min.	Typ.	Max.	Unit
Input levels						
V _{IL}	Low-level input voltage				0.8	V
V _{IH}	High-level input voltage		2.0			V
Output levels						
V _{OL}	Low-level output voltage				0.2	V
V _{OH}	High-level output voltage		VDDH-0.2			V

Table 5.7 Static characteristic : Analog I/O pins (DP/DM)

Symbol	Parameter	Conditions	Min.	Typ.	Max.	Unit
USB2.0 Transceiver (HS)						
Input Levels (differential receiver)						
V _{HSDIFF}	High speed differential input sensitivity	$ V_{I(DP)} - V_{I(DM)} $ measured at the connection as application circuit	300			mV
V _{HSCM}	High speed data signaling common mode voltage range		-50		500	mV
V _{HSSQ}	High speed squelch detection threshold	Squelch detected			100	mV
		No squelch detected	150			mV
V _{HSDSC}	High speed disconnection detection threshold	Disconnection detected	625			mV
		Disconnection not detected			525	mV
Output Levels						
V _{HSOI}	High speed idle level output voltage(differential)		-10		10	mV
V _{HSOL}	High speed low level output voltage(differential)		-10		10	mV
V _{HSOH}	High speed high level output voltage(differential)		-360		400	mV
V _{CHIRPJ}	Chirp-J output voltage (differential)		700		1100	mV
V _{CHIRPK}	Chirp-K output voltage (differential)		-900		-500	mV
Resistance						
R _{DRV}	Driver output impedance	Equivalent resistance used as internal chip only	3	6	9	Ω



		Overall resistance including external resistor	40.5	45	49.5	
Termination						
V_{TERM}	Termination voltage for pull-up resistor on pin RPU		3.0		3.6	V
USB1.1 Transceiver (FS)						
Input Levels (differential receiver)						
V_{DI}	Differential input sensitivity	$ V_{I(DP)} - V_{I(DM)} $	0.2			V
V_{CM}	Differential common mode voltage		0.8		2.5	V
Input Levels (single-ended receivers)						
V_{SE}	Single ended receiver threshold		0.8		2.0	V
Output levels						
V_{OL}	Low-level output voltage		0		0.3	V
V_{OH}	High-level output voltage		2.8		3.6	V

Table 5.8 Dynamic characteristic : Analog I/O pins (DP/DM)

Symbol	Parameter	Conditions	Min.	Typ.	Max.	Unit
Driver Characteristics						
High-Speed Mode						
t_{HSR}	High-speed differential rise time		500			ps
t_{HSF}	High-speed differential fall time		500			ps
Full-Speed Mode						
t_{FR}	Rise time	CL=50pF ; 10 to 90% of $ V_{OH}-V_{OL} $;	4		20	ns
t_{FF}	Fall time	CL=50pF ; 90 to 10% of $ V_{OH}-V_{OL} $;	4		20	ns
t_{FRMA}	Differential rise/fall time matching (t_{FR} / t_{FF})	Excluding the first transition from idle mode	90		110	%
V_{CRS}	Output signal crossover voltage	Excluding the first transition from idle mode	1.3		2.0	V

5.6 Power Switch Feature

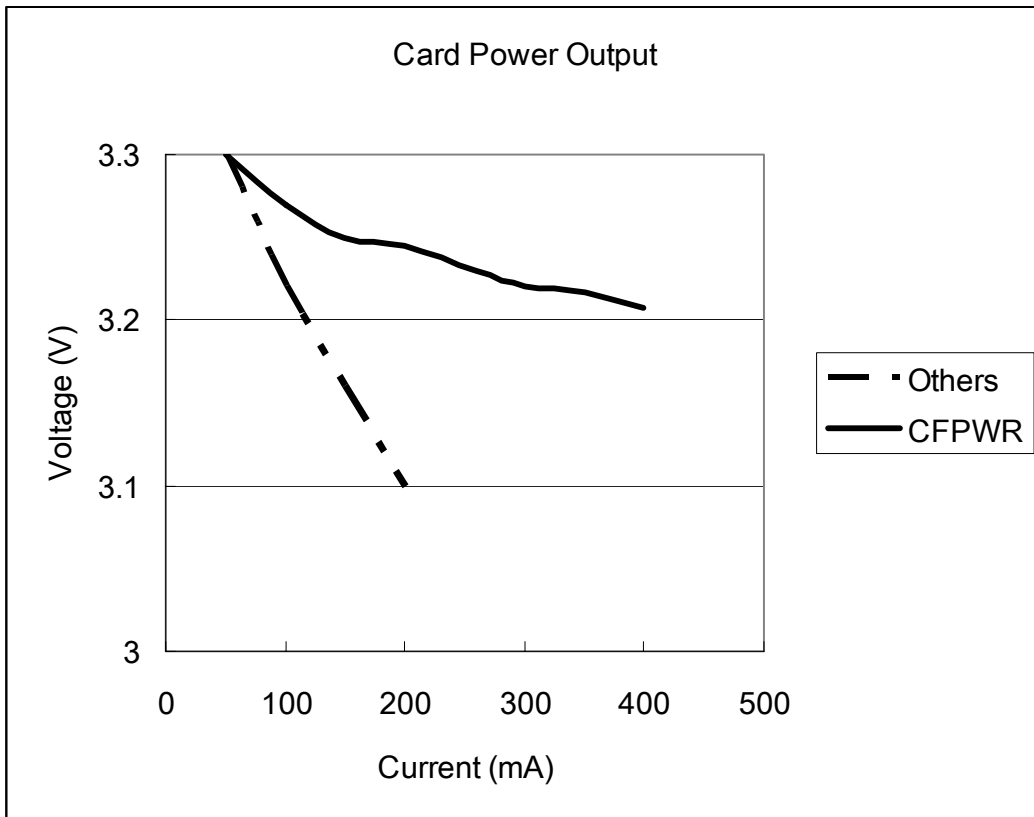

Figure 5.1 Built-in card power switch I-V curve

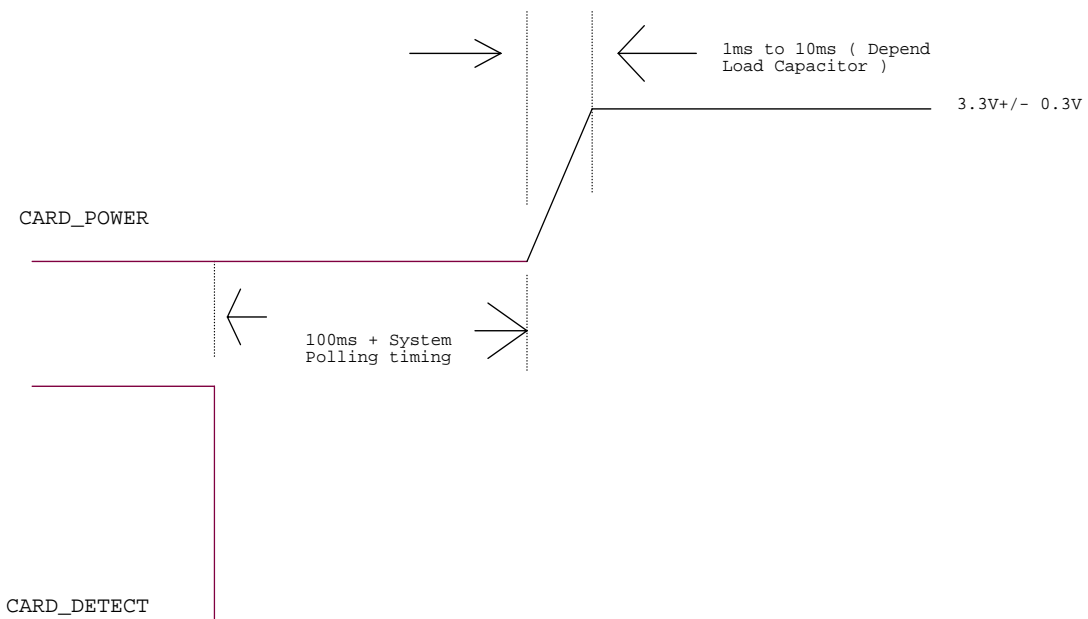
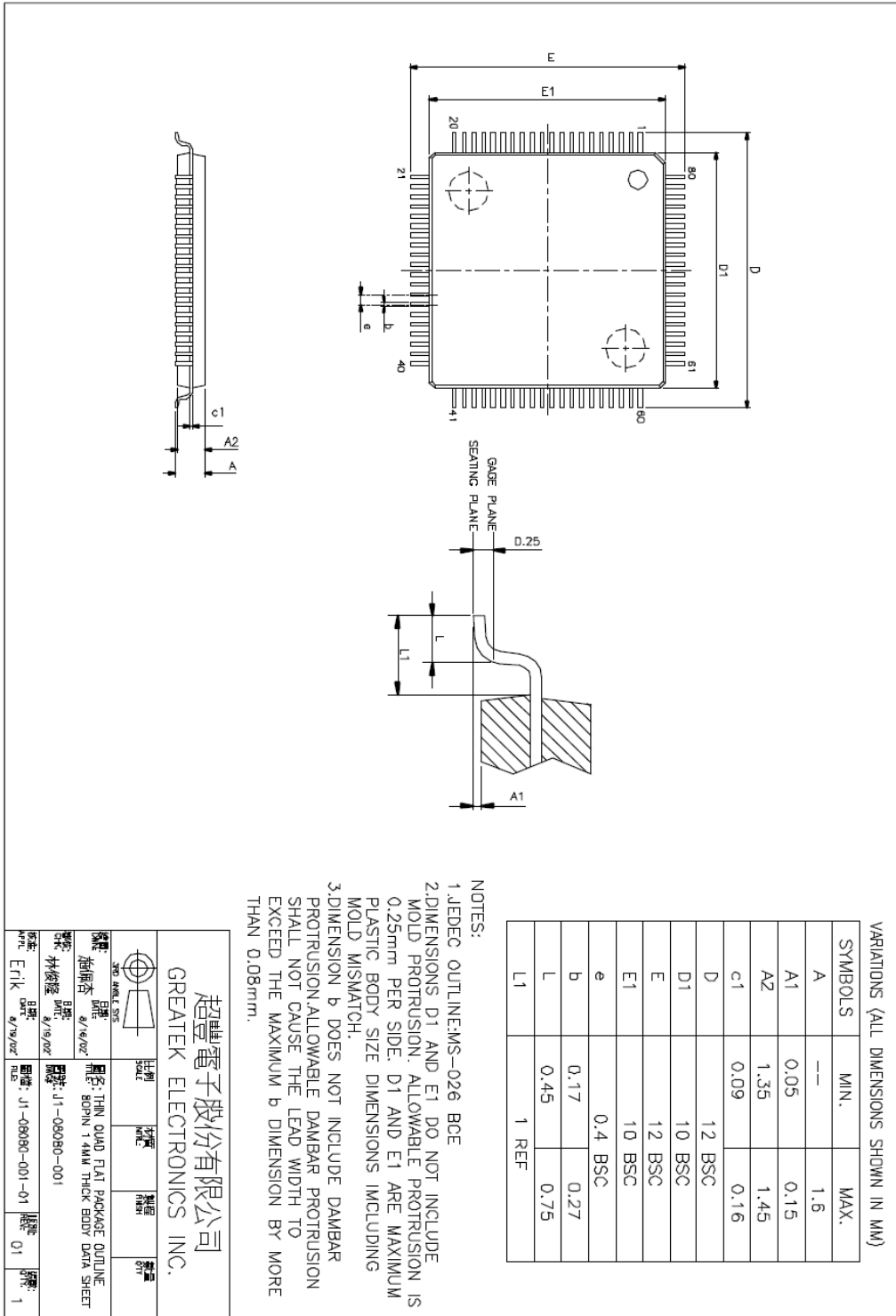

Figure 5.2 Card Detect Power-in Timing

6. Mechanical Information

Figure 6.1 Mechanical Information Diagram





7. Abbreviations

In this chapter some of the terms and abbreviations used throughout the technical reference manual are listed as follows.

SIE	Serial Interface Engine
CF	Compact Flash
MD	Micro Drive
SMC	SmartMedia Card
MS	Memory Stick
SD	Secure Digital
MMC	Multimedia Card
UTMI	USB Transceiver Macrocell Interface

About Alcor Micro, Corp.

Alcor Micro, Corp. designs, develops and markets highly integrated and advanced peripheral semiconductor, and software driver solutions for the personal computer and consumer electronics markets worldwide. We specialize in USB solutions and focus on emerging technology such as USB and IEEE 1394. The company offers a range of semiconductors including controllers for USB hub, integrated keyboard/USB hub and USB Flash memory card reader...etc. Alcor Micro, Corp. is based in Taipei, Taiwan, with sales offices in Taipei, Japan, Korea and California. Alcor Micro is distinguished by its ability to provide innovative solutions for spec-driven products. Innovations like single chip solutions for traditional multiple chip products and on-board voltage regulators enable the company to provide cost-efficiency solutions for the computer peripheral device OEM customers worldwide.