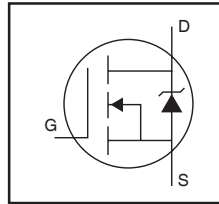


# AUIRFZ44Z AUIRFZ44ZS

HEXFET® Power MOSFET

## Features

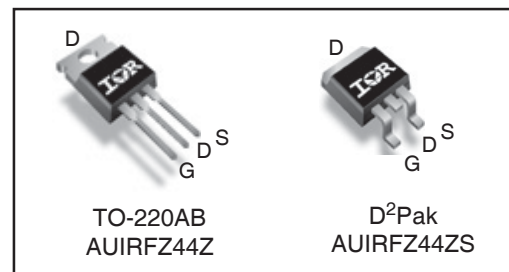
- Advanced Process Technology
- Ultra Low On-Resistance
- 175°C Operating Temperature
- Fast Switching
- Repetitive Avalanche Allowed up to  $T_{jmax}$
- Lead-Free, RoHS Compliant
- Automotive Qualified \*



|                   |               |
|-------------------|---------------|
| $V_{(BR)DSS}$     | <b>55V</b>    |
| $R_{DS(on)}$ max. | <b>13.9mΩ</b> |
| $I_D$             | <b>51A</b>    |

## Description

Specifically designed for Automotive applications, this HEXFET® Power MOSFET utilizes the latest processing techniques to achieve extremely low on-resistance per silicon area. Additional features of this design are a 175°C junction operating temperature, fast switching speed and improved repetitive avalanche rating. These features combine to make this design an extremely efficient and reliable device for use in Automotive applications and a wide variety of other applications.



|          |          |          |
|----------|----------|----------|
| <b>G</b> | <b>D</b> | <b>S</b> |
| Gate     | Drain    | Source   |

## Absolute Maximum Ratings

Stresses beyond those listed under "Absolute Maximum Ratings" may cause permanent damage to the device. These are stress ratings only; and functional operation of the device at these or any other condition beyond those indicated in the specifications is not implied. Exposure to absolute-maximum-rated conditions for extended periods may affect device reliability. The thermal resistance and power dissipation ratings are measured under board mounted and still air conditions. Ambient temperature ( $T_A$ ) is 25°C, unless otherwise specified.

|                                 | Parameter  | Max.                  | Units |
|---------------------------------|--|-----------------------|-------|
| $I_D @ T_C = 25^\circ\text{C}$  | Continuous Drain Current, $V_{GS} @ 10V$                 | 51                    | A     |
| $I_D @ T_C = 100^\circ\text{C}$ | Continuous Drain Current, $V_{GS} @ 10V$ (See Fig. 9)    | 36                    |       |
| $I_{DM}$                        | Pulsed Drain Current ①                                   | 200                   |       |
| $P_D @ T_C = 25^\circ\text{C}$  | Maximum Power Dissipation                                | 80                    | W     |
|                                 | Linear Derating Factor                                   | 0.53                  | W/°C  |
| $V_{GS}$                        | Gate-to-Source Voltage                                   | $\pm 20$              | V     |
| $E_{AS}$                        | Single Pulse Avalanche Energy (Thermally Limited) ②      | 86                    | mJ    |
| $E_{AS}$ (tested)               | Single Pulse Avalanche Energy Tested Value ③             | 105                   |       |
| $I_{AR}$                        | Avalanche Current ①                                      | See Fig.12a,12b,15,16 | A     |
| $E_{AR}$                        | Repetitive Avalanche Energy ④                            |                       | mJ    |
| $T_J$                           | Operating Junction and                                   | -55 to + 175          | °C    |
| $T_{STG}$                       | Storage Temperature Range                                |                       |       |
|                                 | Soldering Temperature, for 10 seconds (1.6mm from case ) |                       |       |
|                                 | Mounting torque, 6-32 or M3 screw                        | 10 lbf•in (1.1N•m)    |       |

## Thermal Resistance

|                 | Parameter                                      | Typ. | Max. | Units |
|-----------------|--|------|------|-------|
| $R_{\theta JC}$ | Junction-to-Case ⑤                             | —    | 1.87 | °C/W  |
| $R_{\theta CS}$ | Case-to-Sink, Flat, Greased Surface            | 0.50 | —    |       |
| $R_{\theta JA}$ | Junction-to-Ambient                            | —    | 62   |       |
| $R_{\theta JA}$ | Junction-to-Ambient (PCB Mount, steady state)⑥ | —    | 40   |       |

HEXFET® is a registered trademark of International Rectifier.

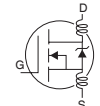
\*Qualification standards can be found at <http://www.irf.com/>

## Static Electrical Characteristics @ $T_J = 25^\circ\text{C}$ (unless otherwise specified)

|                              | Parameter                            | Min. | Typ.  | Max. | Units               | Conditions   |
|------------------------------|--------------------------------------|------|-------|------|---------------------|--|
| $V_{(BR)DSS}$                | Drain-to-Source Breakdown Voltage    | 55   | —     | —    | V                   | $V_{GS} = 0V, I_D = 250\mu A$                        |
| $\Delta BV_{DSS}/\Delta T_J$ | Breakdown Voltage Temp. Coefficient  | —    | 0.054 | —    | V/ $^\circ\text{C}$ | Reference to $25^\circ\text{C}, I_D = 1\text{mA}$    |
| $R_{DS(on)}$                 | Static Drain-to-Source On-Resistance | —    | 11.1  | 13.9 | $m\Omega$           | $V_{GS} = 10V, I_D = 31A$ ④                          |
| $V_{GS(th)}$                 | Gate Threshold Voltage               | 2.0  | —     | 4.0  | V                   | $V_{DS} = V_{GS}, I_D = 250\mu A$                    |
| $g_{fs}$                     | Forward Transconductance             | 22   | —     | —    | S                   | $V_{DS} = 25V, I_D = 31A$                            |
| $I_{DSS}$                    | Drain-to-Source Leakage Current      | —    | —     | 20   | $\mu A$             | $V_{DS} = 55V, V_{GS} = 0V$                          |
|                              |                                      | —    | —     | 250  |                     | $V_{DS} = 55V, V_{GS} = 0V, T_J = 125^\circ\text{C}$ |
| $I_{GSS}$                    | Gate-to-Source Forward Leakage       | —    | —     | 200  | nA                  | $V_{GS} = 20V$                                       |
|                              | Gate-to-Source Reverse Leakage       | —    | —     | -200 |                     | $V_{GS} = -20V$                                      |

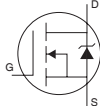
## Dynamic Electrical Characteristics @ $T_J = 25^\circ\text{C}$ (unless otherwise specified)

|                 | Parameter                       | Min. | Typ. | Max. | Units | Conditions  |
|-----------------|---------------------------------|------|------|------|-------|---|
| $Q_g$           | Total Gate Charge               | —    | 29   | 43   | nC    | $I_D = 31A$<br>$V_{DS} = 44V$<br>$V_{GS} = 10V$ ④                           |
| $Q_{gs}$        | Gate-to-Source Charge           | —    | 7.2  | 11   |       |   |
| $Q_{gd}$        | Gate-to-Drain ("Miller") Charge | —    | 12   | 18   |       |   |
| $t_{d(on)}$     | Turn-On Delay Time              | —    | 14   | —    | ns    | $V_{DD} = 28V$<br>$I_D = 31A$<br>$R_G = 15\Omega$<br>$V_{GS} = 10V$ ④       |
| $t_r$           | Rise Time                       | —    | 68   | —    |       |   |
| $t_{d(off)}$    | Turn-Off Delay Time             | —    | 33   | —    |       |   |
| $t_f$           | Fall Time                       | —    | 41   | —    |       |   |
| $L_D$           | Internal Drain Inductance       | —    | 4.5  | —    | nH    | Between lead,<br>6mm (0.25in.)<br>from package<br>and center of die contact |
| $L_S$           | Internal Source Inductance      | —    | 7.5  | —    |       |   |
| $C_{iss}$       | Input Capacitance               | —    | 1420 | —    | pF    | $V_{GS} = 0V$<br>$V_{DS} = 25V$<br>$f = 1.0\text{MHz}$ , See Fig. 5         |
| $C_{oss}$       | Output Capacitance              | —    | 240  | —    |       |   |
| $C_{rss}$       | Reverse Transfer Capacitance    | —    | 130  | —    |       |   |
| $C_{oss}$       | Output Capacitance              | —    | 830  | —    |       |   |
| $C_{oss}$       | Output Capacitance              | —    | 190  | —    |       |   |
| $C_{oss\ eff.}$ | Effective Output Capacitance    | —    | 300  | —    |       |   |



## Diode Characteristics

|          | Parameter                                 | Min.  | Typ. | Max. | Units | Conditions  |
|----------|---|---|------|------|-------|---|
| $I_S$    | Continuous Source Current<br>(Body Diode) | —   | —    | 51   | A     | MOSFET symbol<br>showing the<br>integral reverse<br>p-n junction diode. |
| $I_{SM}$ | Pulsed Source Current<br>(Body Diode) ①   | —   | —    | 200  |       |   |
| $V_{SD}$ | Diode Forward Voltage                     | —   | —    | 1.2  | V     | $T_J = 25^\circ\text{C}, I_S = 31A, V_{GS} = 0V$ ④                      |
| $t_{rr}$ | Reverse Recovery Time                     | —   | 23   | 35   | ns    | $T_J = 25^\circ\text{C}, I_F = 31A, V_{DD} = 28V$                       |
| $Q_{rr}$ | Reverse Recovery Charge                   | —   | 17   | 26   | nC    | $di/dt = 100A/\mu s$ ④  |
| $t_{on}$ | Forward Turn-On Time                      | Intrinsic turn-on time is negligible (turn-on is dominated by $L_S+L_D$ ) |      |      |       |   |



### Notes:

- ① Repetitive rating; pulse width limited by max. junction temperature. (See fig. 11).
- ② Limited by  $T_{Jmax}$ , starting  $T_J = 25^\circ\text{C}$ ,  $L = 0.18\text{mH}$ ,  $R_G = 25\Omega$ ,  $I_{AS} = 31A$ ,  $V_{GS} = 10V$ . Part not recommended for use above this value.
- ③  $I_{SD} \leq 31A$ ,  $di/dt \leq 840A/\mu s$ ,  $V_{DD} \leq V_{(BR)DSS}$ ,  $T_J \leq 175^\circ\text{C}$ .
- ④ Pulse width  $\leq 1.0\text{ms}$ ; duty cycle  $\leq 2\%$ .

- ⑤  $C_{oss\ eff.}$  is a fixed capacitance that gives the same charging time as  $C_{oss}$  while  $V_{DS}$  is rising from 0 to 80%  $V_{DSS}$ .
- ⑥ Limited by  $T_{Jmax}$ , see Fig.12a, 12b, 15, 16 for typical repetitive avalanche performance.
- ⑦ This value determined from sample failure population, starting  $T_J = 25^\circ\text{C}$ ,  $L = 0.18\text{mH}$ ,  $R_G = 25\Omega$ ,  $I_{AS} = 31A$ ,  $V_{GS} = 10V$ .
- ⑧ This is applied to D<sup>2</sup>Pak, when mounted on 1" square PCB (FR-4 or G-10 Material). For recommended footprint and soldering techniques refer to application note #AN-994.
- ⑨  $R_\theta$  is rated at  $T_J$  of approximately  $90^\circ\text{C}$ .

**Qualification Information<sup>†</sup>**

|                                   |                      |   |      |
|-----------------------------------|----------------------|---|------|
| <b>Qualification Level</b>        |                      | Automotive<br>(per AEC-Q101) <sup>††</sup>  |      |
|                                   |                      | Comments: This part number(s) passed Automotive qualification. IR's Industrial and Consumer qualification level is granted by extension of the higher Automotive level. |      |
| <b>Moisture Sensitivity Level</b> |                      | TO-220AB  | N/A  |
|                                   |                      | TO-262  | N/A  |
|                                   |                      | D <sup>2</sup> Pak  | MSL1 |
| <b>ESD</b>                        | Machine Model        | Class M2 (200V)<br>AEC-Q101-002   |      |
|                                   | Human Body Model     | Class H1A (500V)<br>AEC-Q101-001  |      |
|                                   | Charged Device Model | Class C5 (1125V)<br>AEC-Q101-005  |      |
| <b>RoHS Compliant</b>             |                      | Yes   |      |

† Qualification standards can be found at International Rectifier's web site: <http://www.irf.com/>

†† Exceptions to AEC-Q101 requirements are noted in the qualification report.

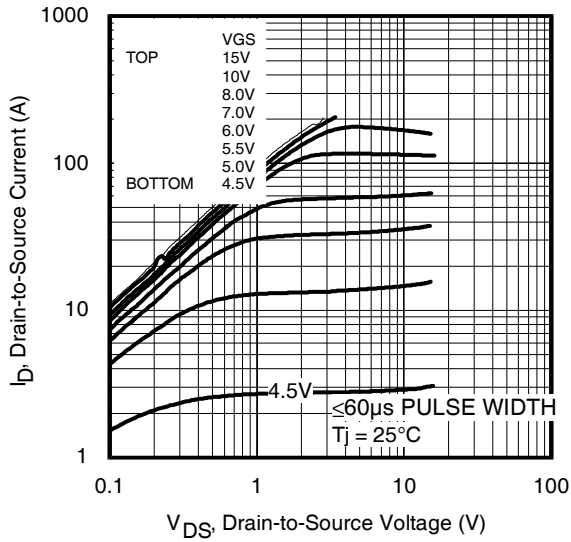


Fig 1. Typical Output Characteristics

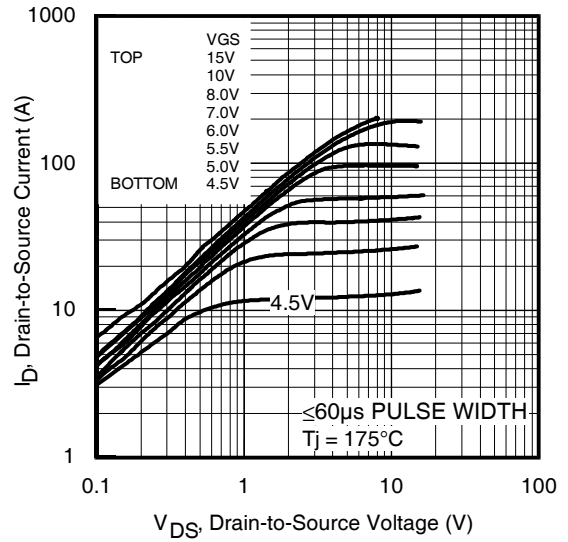


Fig 2. Typical Output Characteristics

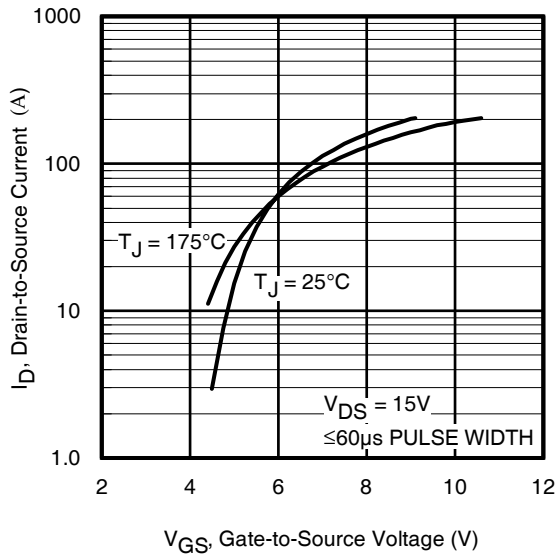


Fig 3. Typical Transfer Characteristics

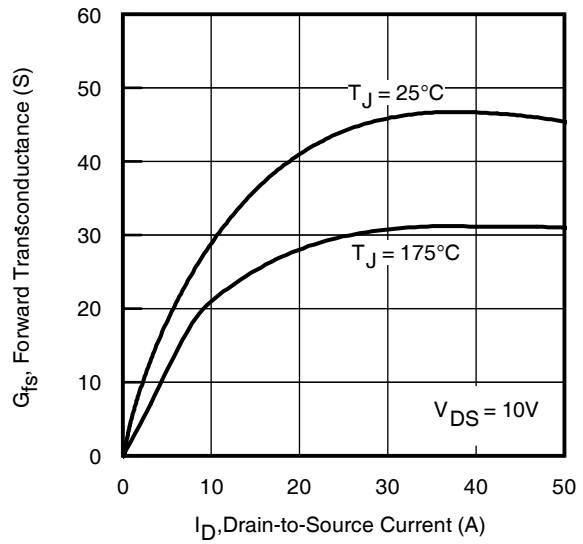
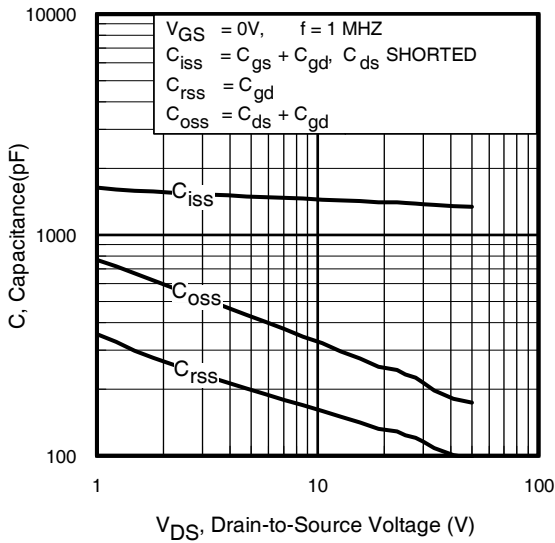
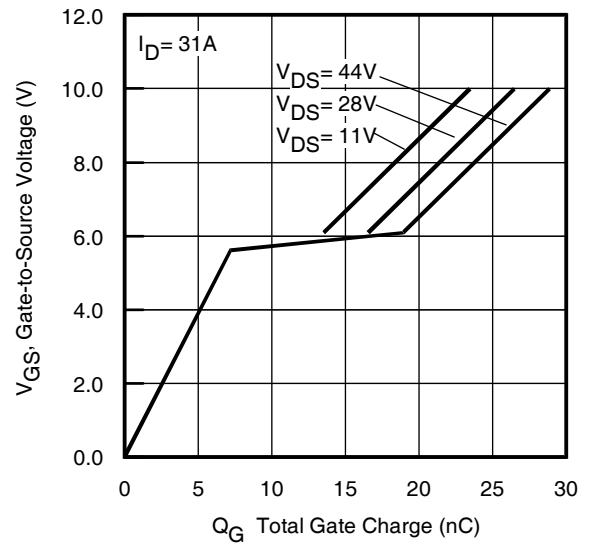


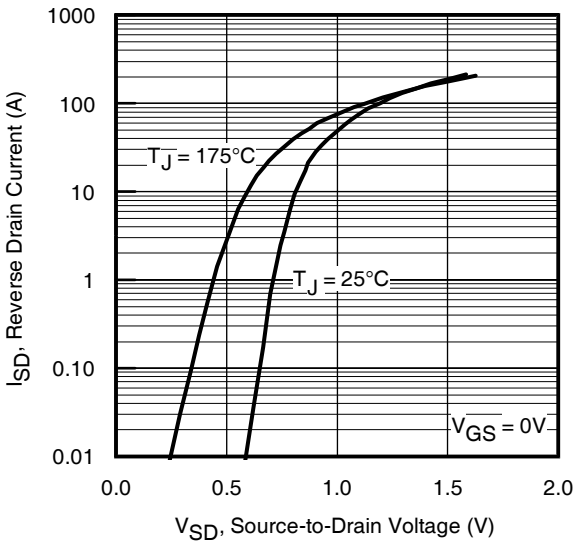
Fig 4. Typical Forward Transconductance vs. Drain Current



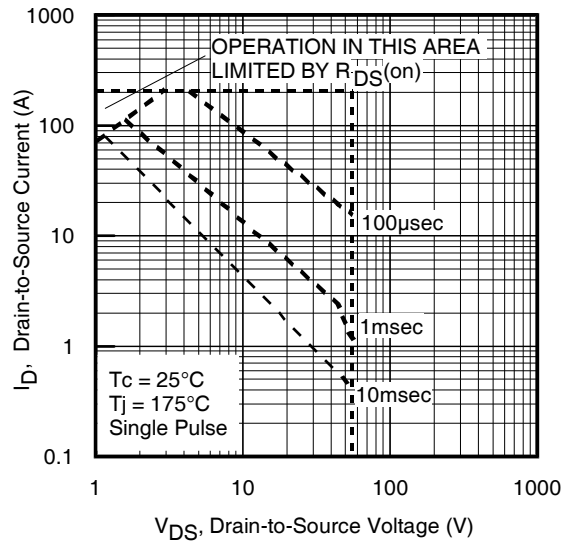
**Fig 5.** Typical Capacitance vs. Drain-to-Source Voltage



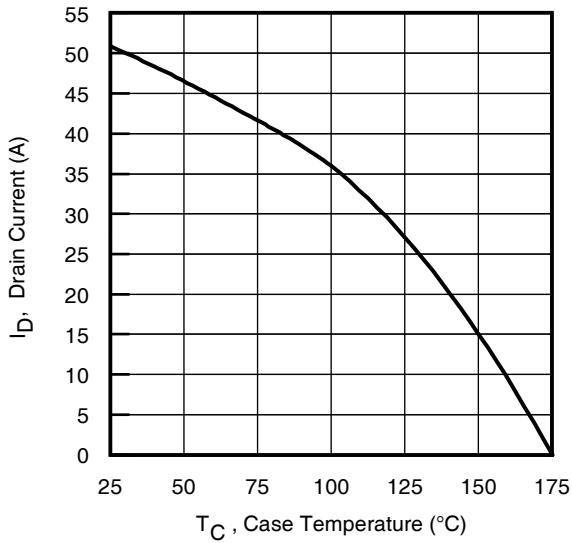
**Fig 6.** Typical Gate Charge vs. Gate-to-Source Voltage



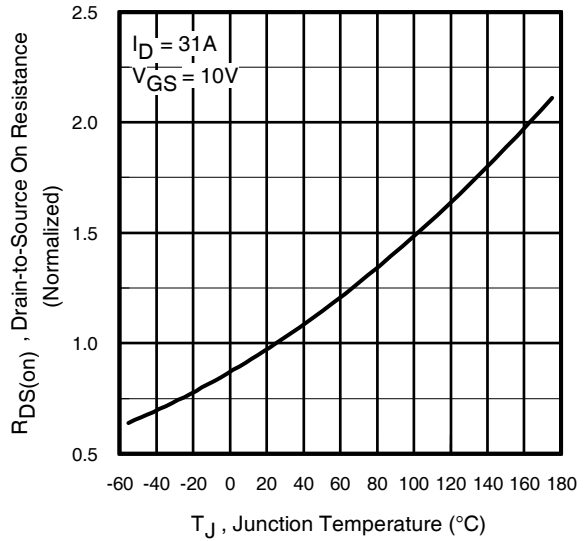
**Fig 7.** Typical Source-Drain Diode Forward Voltage



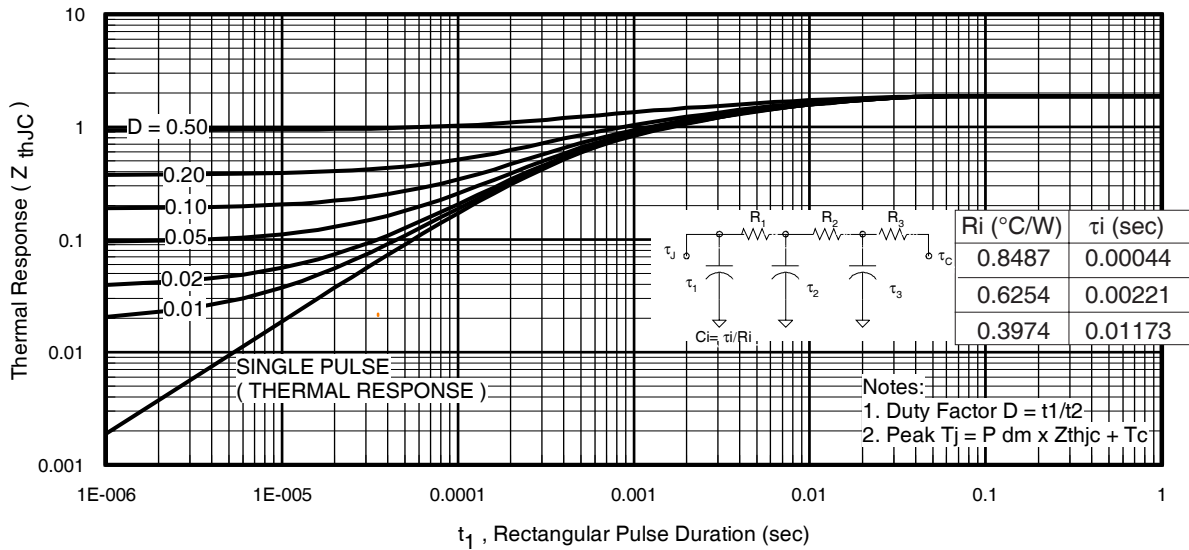
**Fig 8.** Maximum Safe Operating Area



**Fig 9.** Maximum Drain Current vs. Case Temperature



**Fig 10.** Normalized On-Resistance vs. Temperature



**Fig 11.** Maximum Effective Transient Thermal Impedance, Junction-to-Case

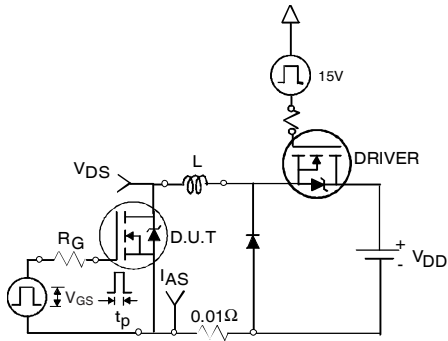


Fig 12a. Unclamped Inductive Test Circuit

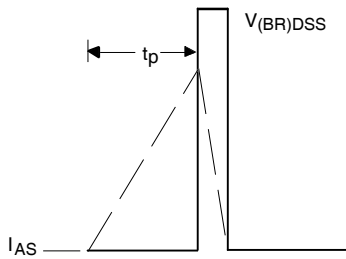


Fig 12b. Unclamped Inductive Waveforms

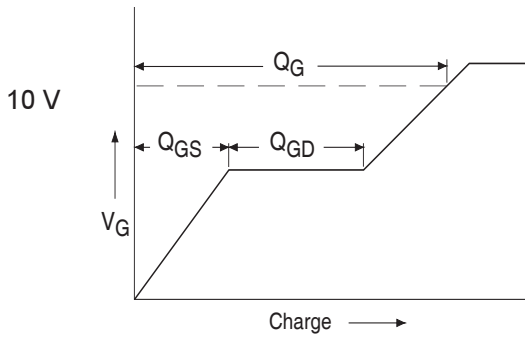


Fig 13a. Basic Gate Charge Waveform

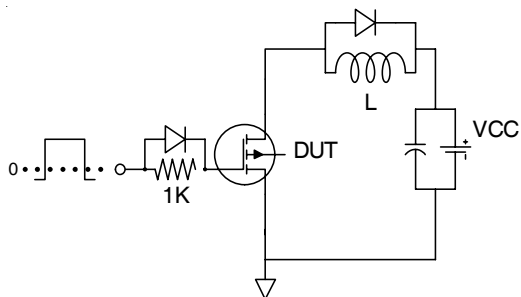


Fig 13b. Gate Charge Test Circuit

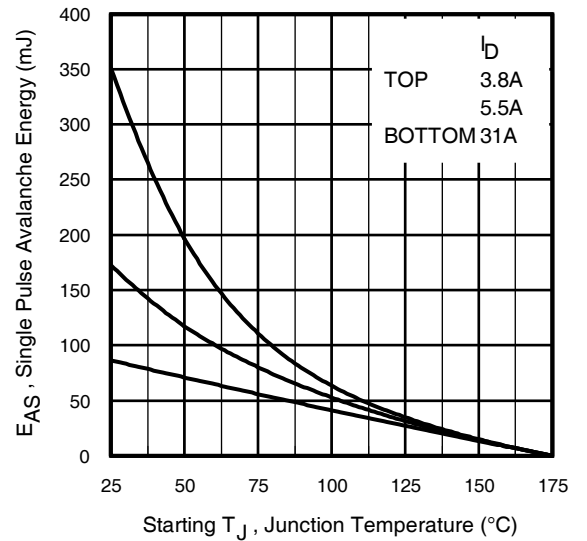


Fig 12c. Maximum Avalanche Energy vs. Drain Current

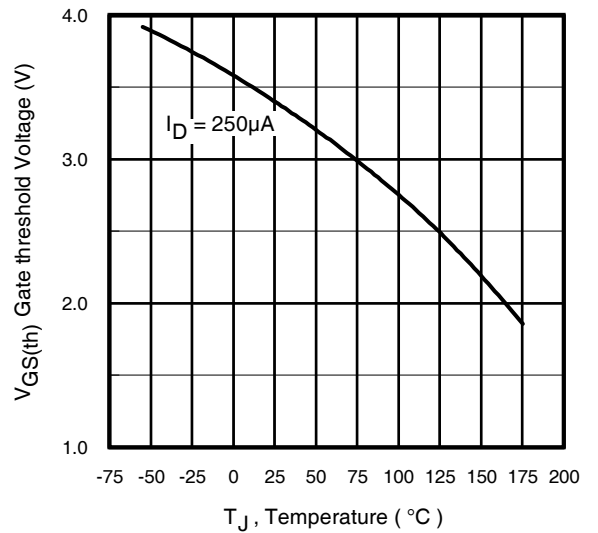


Fig 14. Threshold Voltage vs. Temperature

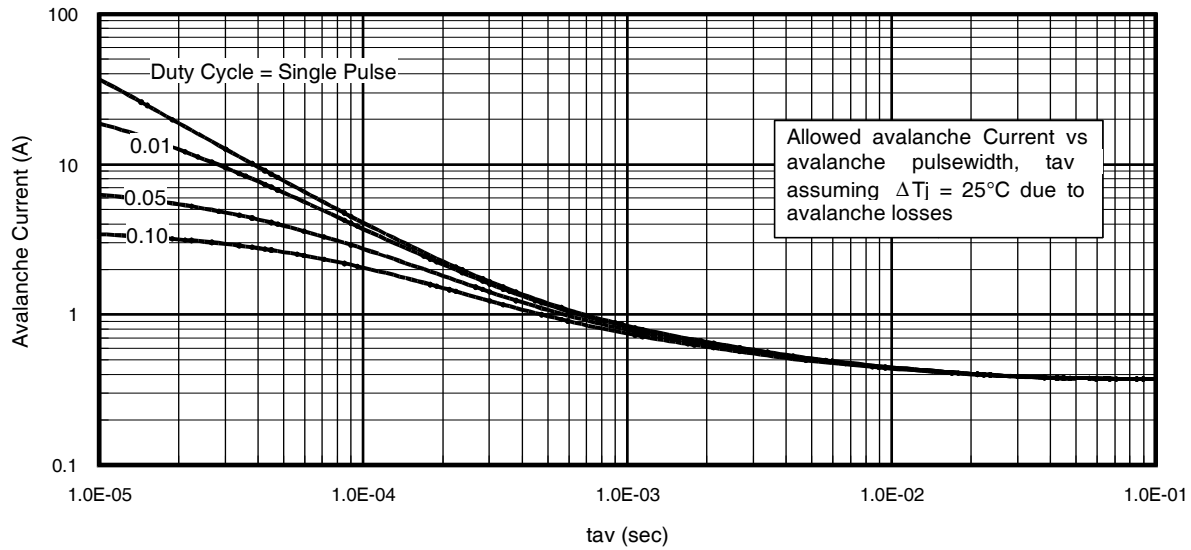


Fig 15. Typical Avalanche Current vs.Pulsewidth

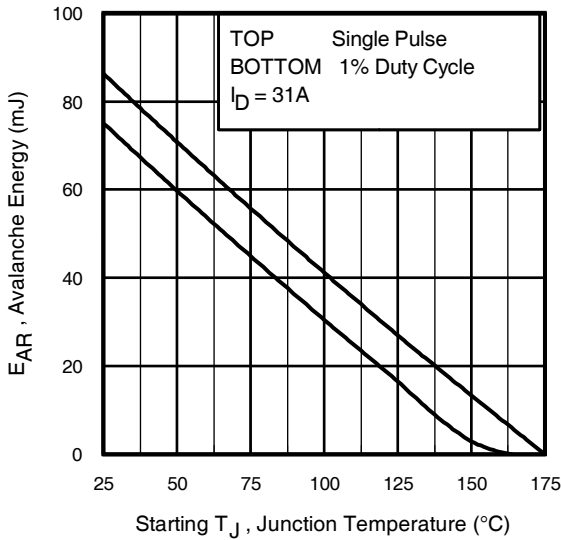


Fig 16. Maximum Avalanche Energy vs. Temperature

**Notes on Repetitive Avalanche Curves , Figures 15, 16:  
(For further info, see AN-1005 at www.irf.com)**

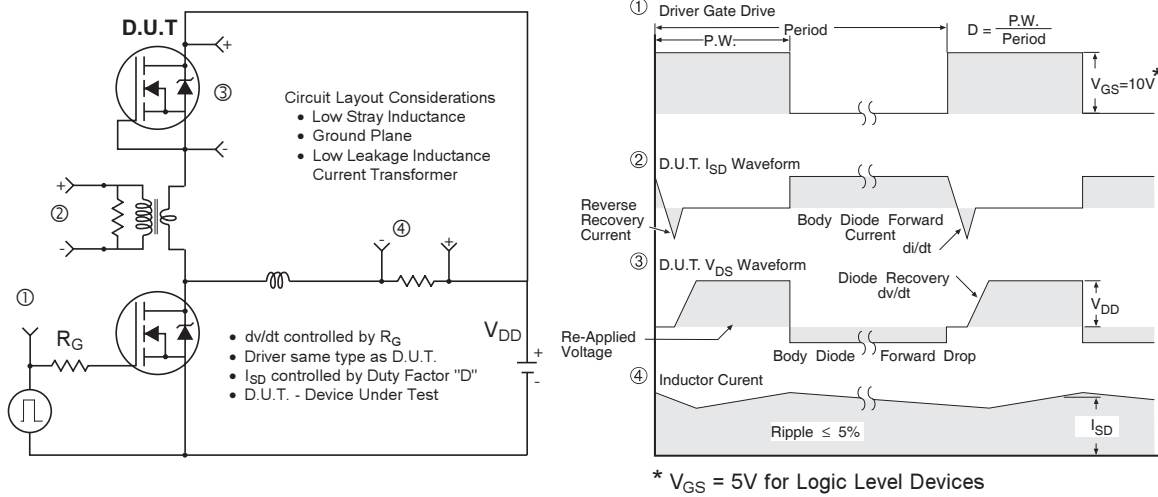
1. Avalanche failures assumption:  
Purely a thermal phenomenon and failure occurs at a temperature far in excess of  $T_{jmax}$ . This is validated for every part type.
2. Safe operation in Avalanche is allowed as long as  $T_{jmax}$  is not exceeded.
3. Equation below based on circuit and waveforms shown in Figures 12a, 12b.
4.  $P_{D(ave)}$  = Average power dissipation per single avalanche pulse.
5.  $BV$  = Rated breakdown voltage (1.3 factor accounts for voltage increase during avalanche).
6.  $I_{av}$  = Allowable avalanche current.
7.  $\Delta T$  = Allowable rise in junction temperature, not to exceed  $T_{jmax}$  (assumed as 25°C in Figure 15, 16).  
 $t_{av}$  = Average time in avalanche.  
 $D$  = Duty cycle in avalanche =  $t_{av} \cdot f$   
 $Z_{thJC}(D, t_{av})$  = Transient thermal resistance, see figure 11)

$$P_{D(ave)} = 1/2 ( 1.3 \cdot BV \cdot I_{av} ) = \Delta T / Z_{thJC}$$

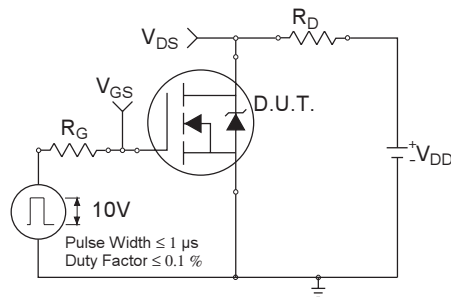
$$I_{av} = 2\Delta T / [1.3 \cdot BV \cdot Z_{th}]$$

$$E_{AS(AR)} = P_{D(ave)} \cdot t_{av}$$

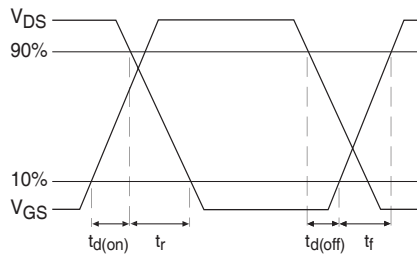




**Fig 17. Peak Diode Recovery dv/dt Test Circuit for N-Channel HEXFET® Power MOSFETs**



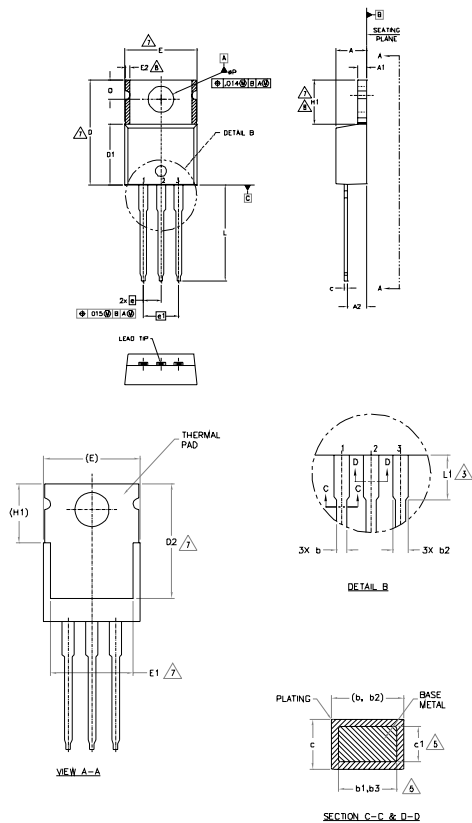
**Fig 18a. Switching Time Test Circuit**



**Fig 18b. Switching Time Waveforms**

## TO-220AB Package Outline

Dimensions are shown in millimeters (inches)



- NOTES:
- 1.- DIMENSIONING AND TOLERANCING AS PER ASME Y14.5 M- 1994.
  - 2.- DIMENSIONS ARE SHOWN IN INCHES (MILLIMETERS).
  - 3.- LEAD DIMENSION AND FINISH UNCONTROLLED IN L1.
  - 4.- DIMENSION D, D1 & E DO NOT INCLUDE MOLD FLASH. MOLD FLASH SHALL NOT EXCEED .005" (0.127) PER SIDE. THESE DIMENSIONS ARE MEASURED AT THE OUTERMOST EXTREMES OF THE PLASTIC BODY.
  - 5.- DIMENSION b1, b3 & c1 APPLY TO BASE METAL ONLY.
  - 6.- CONTROLLING DIMENSION - INCHES.
  - 7.- THERMAL PAD CONTOUR OPTIONAL WITHIN DIMENSIONS E,H1,D2 & E1
  - 8.- DIMENSION E2 X H1 DEFINE A ZONE WHERE STAMPING AND SINGULATION IRREGULARITIES ARE ALLOWED.
  - 9.- OUTLINE CONFORMS TO JEDEC TO-220, EXCEPT A2 (max.) AND D2 (min.) WHERE DIMENSIONS ARE DERIVED FROM THE ACTUAL PACKAGE OUTLINE.

| SYMBOL | DIMENSIONS  |       |          |      | NOTES |
|--------|-------------|-------|----------|------|-------|
|        | MILLIMETERS |       | INCHES   |      |       |
|        | MIN.        | MAX.  | MIN.     | MAX. |       |
| A      | 3.56        | 4.83  | .140     | .190 |       |
| A1     | 0.51        | 1.40  | .020     | .055 |       |
| A2     | 2.03        | 2.92  | .080     | .115 |       |
| b      | 0.38        | 1.01  | .015     | .040 |       |
| b1     | 0.38        | 0.97  | .015     | .038 | 5     |
| b2     | 1.14        | 1.78  | .045     | .070 |       |
| b3     | 1.14        | 1.73  | .045     | .068 | 5     |
| c      | 0.36        | 0.61  | .014     | .024 |       |
| c1     | 0.36        | 0.56  | .014     | .022 | 5     |
| d      | 14.22       | 16.51 | .560     | .650 | 4     |
| D1     | 8.38        | 9.02  | .330     | .355 |       |
| D2     | 11.68       | 12.88 | .460     | .507 | 7     |
| E      | 9.65        | 10.67 | .380     | .420 | 4,7   |
| E1     | 6.86        | 8.89  | .270     | .350 | 7     |
| E2     | -           | 0.76  | -        | .030 | 8     |
| e      | 2.54 BSC    |       | .100 BSC |      |       |
| e1     | 5.08 BSC    |       | .200 BSC |      |       |
| H1     | 5.84        | 6.86  | .230     | .270 | 7,8   |
| L      | 12.70       | 14.73 | .500     | .580 |       |
| L1     | 3.56        | 4.06  | .140     | .160 | 3     |
| ØP     | 3.54        | 4.08  | .139     | .161 |       |
| O      | 2.54        | 3.42  | .100     | .135 |       |

**LEAD ASSIGNMENTS**

ØE/E1

1- GATE

2- DRAIN

3- SOURCE

**ØP/ØA/ØB/ØC**

1- GATE

2- COLLECTOR

3- EMITTER

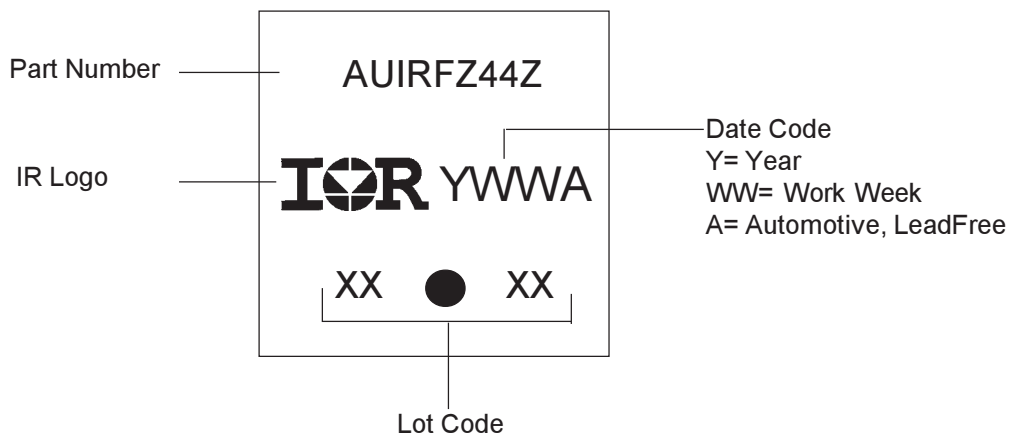
**ØD/ØE**

1- ANODE

2- CATHODE

3- ANODE

## TO-220AB Part Marking Information

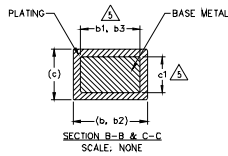
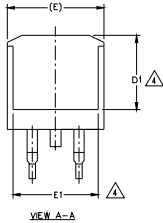
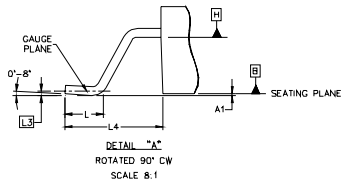
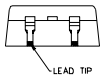
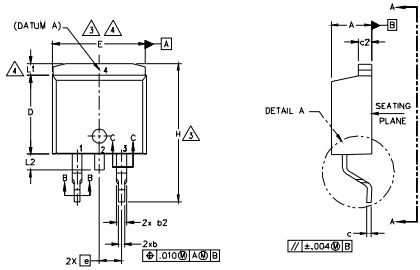


TO-220AB packages are not recommended for Surface Mount Application.

Note: For the most current drawing please refer to IR website at <http://www.irf.com/package/>

## D<sup>2</sup>Pak (TO-263AB) Package Outline

Dimensions are shown in millimeters (inches)



### LEAD ASSIGNMENTS

#### DIODES

- 1.- ANODE (TWO DIE) / OPEN (ONE DIE)
- 2, 4.- CATHODE
- 3.- ANODE

#### HEXFET

- 1.- GATE
- 2, 4.- DRAIN
- 3.- SOURCE

#### IGBTs, CrPACK

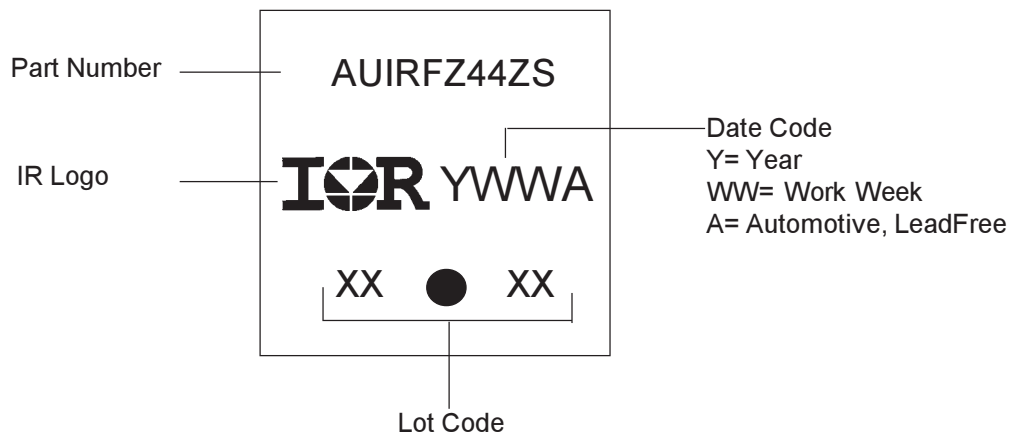
- 1.- GATE
- 2, 4.- COLLECTOR
- 3.- EMITTER

| SYMBOL | DIMENSIONS  |       |          |      | NOTES |
|--------|-------------|-------|----------|------|-------|
|        | MILLIMETERS |       | INCHES   |      |       |
|        | MIN.        | MAX.  | MIN.     | MAX. |       |
| A      | 4.06        | 4.83  | .160     | .190 |       |
| A1     | 0.00        | 0.254 | .000     | .010 |       |
| b      | 0.51        | 0.99  | .020     | .039 | 5     |
| b1     | 0.51        | 0.89  | .020     | .035 |       |
| b2     | 1.14        | 1.78  | .045     | .070 | 5     |
| b3     | 1.14        | 1.73  | .045     | .068 |       |
| c      | 0.38        | 0.74  | .015     | .029 |       |
| c1     | 0.38        | 0.58  | .015     | .023 | 5     |
| c2     | 1.14        | 1.65  | .045     | .065 |       |
| D      | 8.38        | 9.65  | .330     | .380 | 3     |
| D1     | 6.86        | -     | .270     | -    | 4     |
| E      | 9.65        | 10.67 | .380     | .420 | 3,4   |
| E1     | 6.22        | -     | .245     | -    | 4     |
| e      | 2.54 BSC    |       | .100 BSC |      |       |
| H      | 14.61       | 15.88 | .575     | .625 |       |
| L      | 1.78        | 2.79  | .070     | .110 |       |
| L1     | -           | 1.65  | -        | .066 | 4     |
| L2     | -           | 1.78  | -        | .070 |       |
| L3     | 0.25 BSC    |       | .010 BSC |      |       |
| L4     | 4.78        | 5.28  | .188     | .208 |       |

### NOTES:

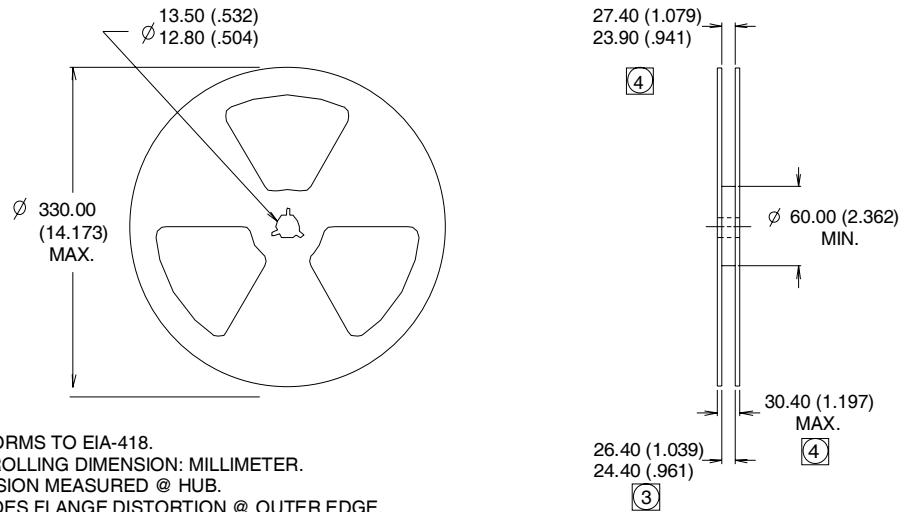
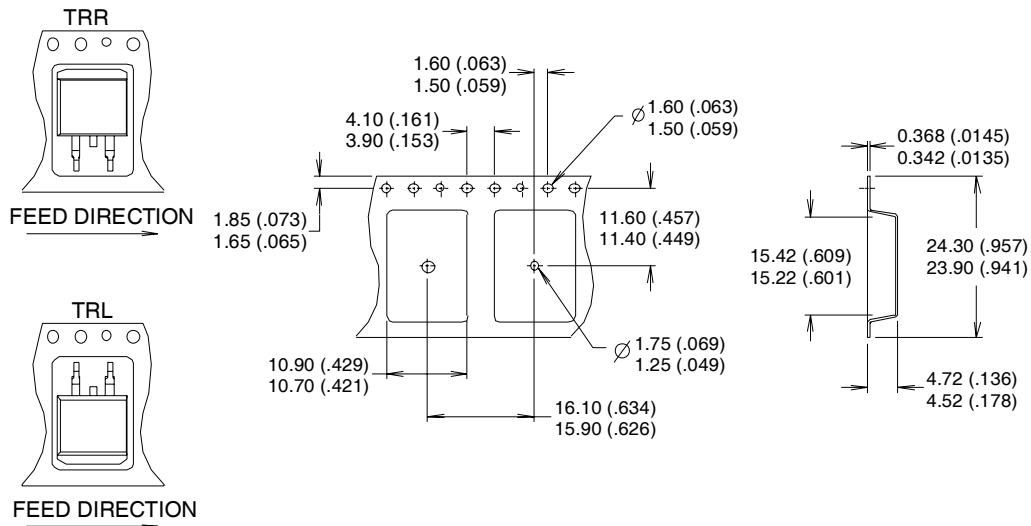
1. DIMENSIONING AND TOLERANCING PER ASME Y14.5M-1994
2. DIMENSIONS ARE SHOWN IN MILLIMETERS [INCHES].
3. DIMENSION D & E DO NOT INCLUDE MOLD FLASH. MOLD FLASH SHALL NOT EXCEED 0.127 [0.005"] PER SIDE. THESE DIMENSIONS ARE MEASURED AT THE OUTMOST EXTREMES OF THE PLASTIC BODY AT DATUM H.
4. THERMAL PAD CONTOUR OPTIONAL WITHIN DIMENSION E, L1, D1 & E1.
5. DIMENSION b1 AND c1 APPLY TO BASE METAL ONLY.
6. DATUM A & B TO BE DETERMINED AT DATUM PLANE H.
7. CONTROLLING DIMENSION: INCH.
8. OUTLINE CONFORMS TO JEDEC OUTLINE TO-263AB.

## D<sup>2</sup>Pak (TO-263AB) Part Marking Information



Note: For the most current drawing please refer to IR website at <http://www.irf.com/package/>

## D<sup>2</sup>Pak Tape & Reel Information



Note: For the most current drawing please refer to IR website at <http://www.irf.com/package/>

### Ordering Information

| Base part  | Package Type | Standard Pack       |          | Complete Part Number |
|------------|--------------|---------------------|----------|----------------------|
|            |              | Form                | Quantity |                      |
| AUIRFZ44Z  | TO-220       | Tube                | 50       | AUIRFZ44Z            |
| AUIRFZ44ZS | D2Pak        | Tube                | 50       | AUIRFZ44ZS           |
|            |              | Tape and Reel Left  | 800      | AUIRFZ44ZSTRL        |
|            |              | Tape and Reel Right | 800      | AUIRFZ44ZSTRR        |
|            |              |                     |          |                      |
|            |              |                     |          |                      |
|            |              |                     |          |                      |
|            |              |                     |          |                      |
|            |              |                     |          |                      |
|            |              |                     |          |                      |
|            |              |                     |          |                      |
|            |              |                     |          |                      |

**IMPORTANT NOTICE**

Unless specifically designated for the automotive market, International Rectifier Corporation and its subsidiaries (IR) reserve the right to make corrections, modifications, enhancements, improvements, and other changes to its products and services at any time and to discontinue any product or services without notice. Part numbers designated with the "AU" prefix follow automotive industry and / or customer specific requirements with regards to product discontinuance and process change notification. All products are sold subject to IR's terms and conditions of sale supplied at the time of order acknowledgment.

IR warrants performance of its hardware products to the specifications applicable at the time of sale in accordance with IR's standard warranty. Testing and other quality control techniques are used to the extent IR deems necessary to support this warranty. Except where mandated by government requirements, testing of all parameters of each product is not necessarily performed.

IR assumes no liability for applications assistance or customer product design. Customers are responsible for their products and applications using IR components. To minimize the risks with customer products and applications, customers should provide adequate design and operating safeguards.

Reproduction of IR information in IR data books or data sheets is permissible only if reproduction is without alteration and is accompanied by all associated warranties, conditions, limitations, and notices. Reproduction of this information with alterations is an unfair and deceptive business practice. IR is not responsible or liable for such altered documentation. Information of third parties may be subject to additional restrictions.

Resale of IR products or serviced with statements different from or beyond the parameters stated by IR for that product or service voids all express and any implied warranties for the associated IR product or service and is an unfair and deceptive business practice. IR is not responsible or liable for any such statements.

IR products are not designed, intended, or authorized for use as components in systems intended for surgical implant into the body, or in other applications intended to support or sustain life, or in any other application in which the failure of the IR product could create a situation where personal injury or death may occur. Should Buyer purchase or use IR products for any such unintended or unauthorized application, Buyer shall indemnify and hold International Rectifier and its officers, employees, subsidiaries, affiliates, and distributors harmless against all claims, costs, damages, and expenses, and reasonable attorney fees arising out of, directly or indirectly, any claim of personal injury or death associated with such unintended or unauthorized use, even if such claim alleges that IR was negligent regarding the design or manufacture of the product.

IR products are neither designed nor intended for use in military/aerospace applications or environments unless the IR products are specifically designated by IR as military-grade or "enhanced plastic." Only products designated by IR as military-grade meet military specifications. Buyers acknowledge and agree that any such use of IR products which IR has not designated as military-grade is solely at the Buyer's risk, and that they are solely responsible for compliance with all legal and regulatory requirements in connection with such use.

IR products are neither designed nor intended for use in automotive applications or environments unless the specific IR products are designated by IR as compliant with ISO/TS 16949 requirements and bear a part number including the designation "AU". Buyers acknowledge and agree that, if they use any non-designated products in automotive applications, IR will not be responsible for any failure to meet such requirements.

For technical support, please contact IR's Technical Assistance Center

<http://www.irf.com/technical-info/>

**WORLD HEADQUARTERS:**

233 Kansas St., El Segundo, California 90245

Tel: (310) 252-7105