



Analog Video To Digital Adaptor Board

Model: AVD-1000 P/N: 41601872X-3
HVD-1000 P/N: 41601883X-3

INSTRUCTIONS

CONTENTS

Page:	2. Introduction
	4. Diagram for connectors
	5. System Design
	6. Board Dimension
	7. Summary for Jumper settings
	8. Summary of Pin Outs
	11 Appendix I Mode Support Table
	12. Appendix II - RS-232 control protocols
	13. Appendix III – AVD-1000 connect with SVX-1920v3
	15. WARRANTY
	16. Contact Details
	17. Revision history

It is essential that these instructions are read and understood before connecting or powering up this controller.

Introduction

AVD-1000

AVD-1000 is designed to select one of analog video input sources (Composite, S-Video and SD component) and convert to digital format, HDMI and TTL (To be supported)

- AVD-1000 can be used independently without connecting with DV controller.
- It could be an add-on board for Digital View controllers (eg. connect with SVX1920v3) to provide composite , S-Video and SD component input

The video input sources can be selected through the on board tact switch and RS-232 interface. The active video source is indicated on the LED beside each video input connector.

Video Inputs Signal Format

- NTSC (M, J, 4.43)
- PAL (M, BDGHI, Nc, 60)

Video Output Signal Format:

- HDMI
- TTL (To be supported)

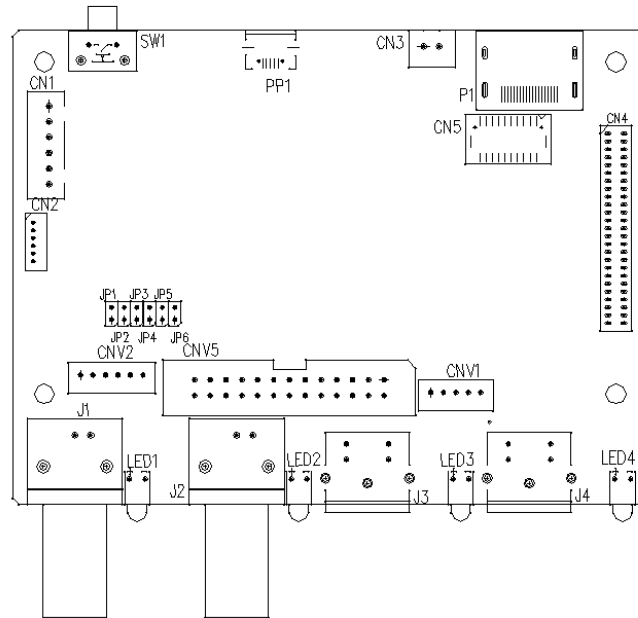

On board LED is located beside each video input connector. It turns on when the source is selected. If no video signal is present in the selected source, the LED blinks.

Video inputs can be selected by:

- On board tact switch to toggle from one input to another one sequentially.
- RS-232 commands

The last selected video input source will be memorized after power cycle.

HVD-1000

Harsh Environment version of the HVD-1000, provides full AVD-1000 feature set, plus wide range operating temperature; shock and vibration tolerance and conformal coating for protection against humidity and dusty. The operating temperature range of HVD-1000 is from -40oC to +80oC * .

** Overall suitability for usage in critical applications must be independently tested and verified by the user.*

Diagram for connectors

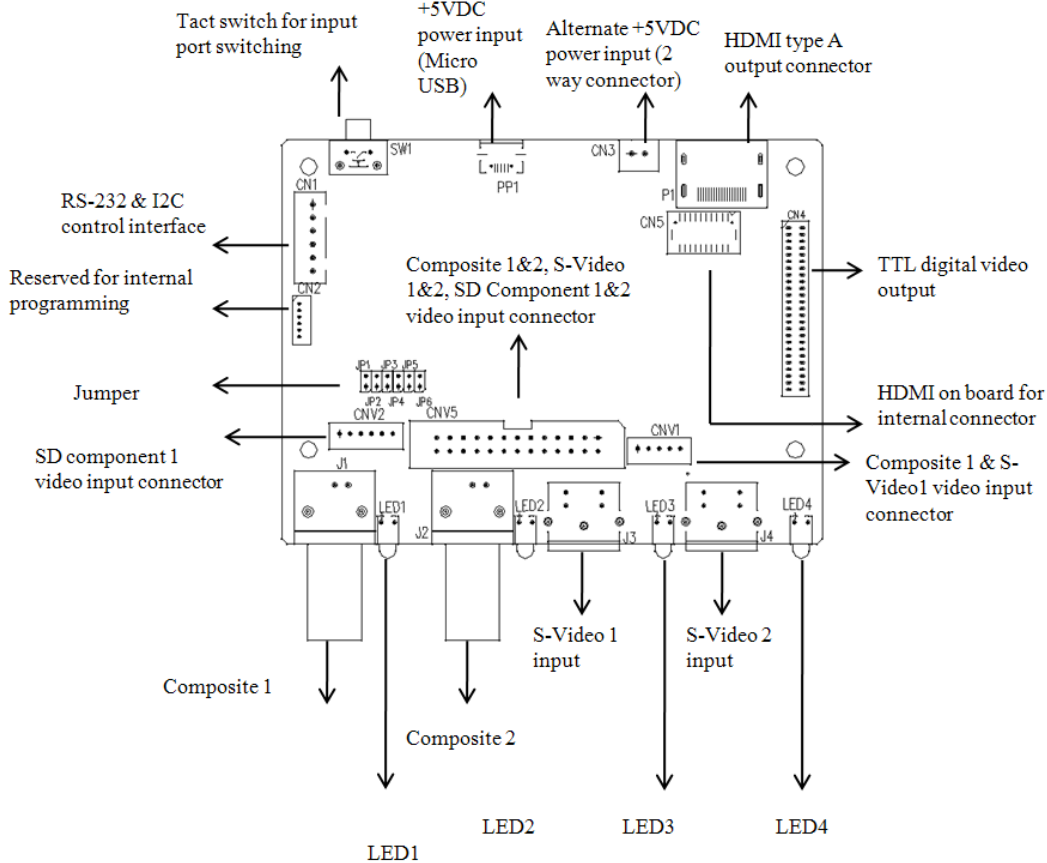

Connector	Purpose	Description
CN1	RS-232 & I2C control interface	JST 6-way, B6B-XH-A (Matching type : XHP-6)
CN2	Reserved for internal programming	Reserved
CN3	Alternate +5VDC power input (2 way connector)	JST 2-way, B2B-XH-A (Matching type : XHP-2)
CN4	TTL digital video output (To be supported)	2 x 25 ways, 2.54x1.27 header (Matching connector type : DF13-40DS-1.25C) (Matching ribbon cable : P/N 426171100-3)
CN5	HDMI on board for internal connector	JST BM20B-SRDS (Matching type : SHDR-20V-S-B)
CNV1	Composite 1 & S-Video1 video input connector	JST 5-way, B5B-PH-K (Matching type : PHR-5) (Matching video cable P/N 426000500-3)
CNV2	SD component 1 video input connector	JST 6-way, B6B-PH-K (Matching type : PHR-6) (Matching video cable P/N 426000600-3)
CNV5	Composite 1&2, S-Video 1&2, SD Component 1&2 video input connector	Header pin 13x2 (Matching video cable P/N 426000800-3)
P1	HDMI type A output connector	HDMI connector
J1	Composite 1 input	BNC connector
J2	Composite 2 input	BNC connector
J3	S-Video 1 input	Mini din 4-way
J4	S-Video 2 input	Mini din 4-way
PP1	+5VDC power input	Micro USB
SW1	For input port switching	Tact switch

System Design

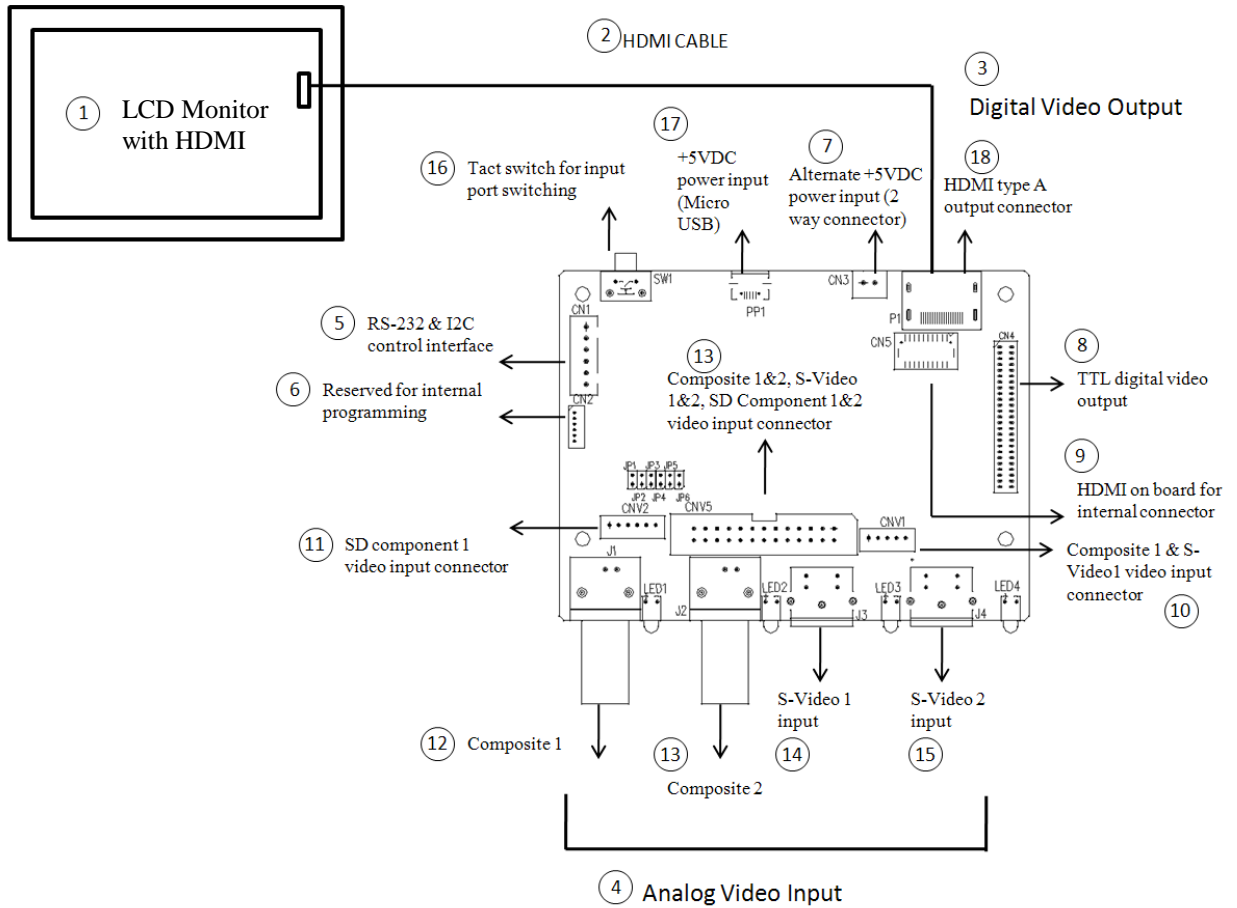

Summary

1. LCD Monitor with HDMI
2. HDMI CABLE
3. Digital Video Output
4. Analog Video Input
5. RS-232 & I2C control interface
6. Reserved for internal programming
7. Alternate +5VDC power input (2 way connector)
8. TTL digital video output (To be supported)
9. HDMI on board for internal connector
10. Composite 1 & S-Video1 video input connector
11. SD component 1 video input connector
12. Composite 1
13. Composite 2
14. S-Video 1 input
15. S-Video 2 input
16. Tact switch for input port switching
17. +5VDC power input (Micro USB)
18. HDMI type A output connector

BOARD DIMENSIONS

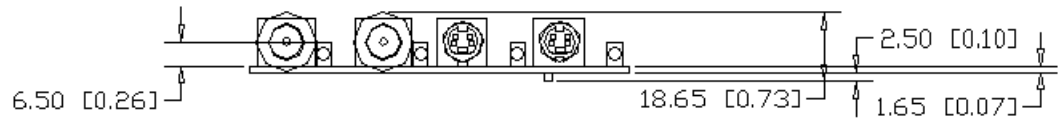
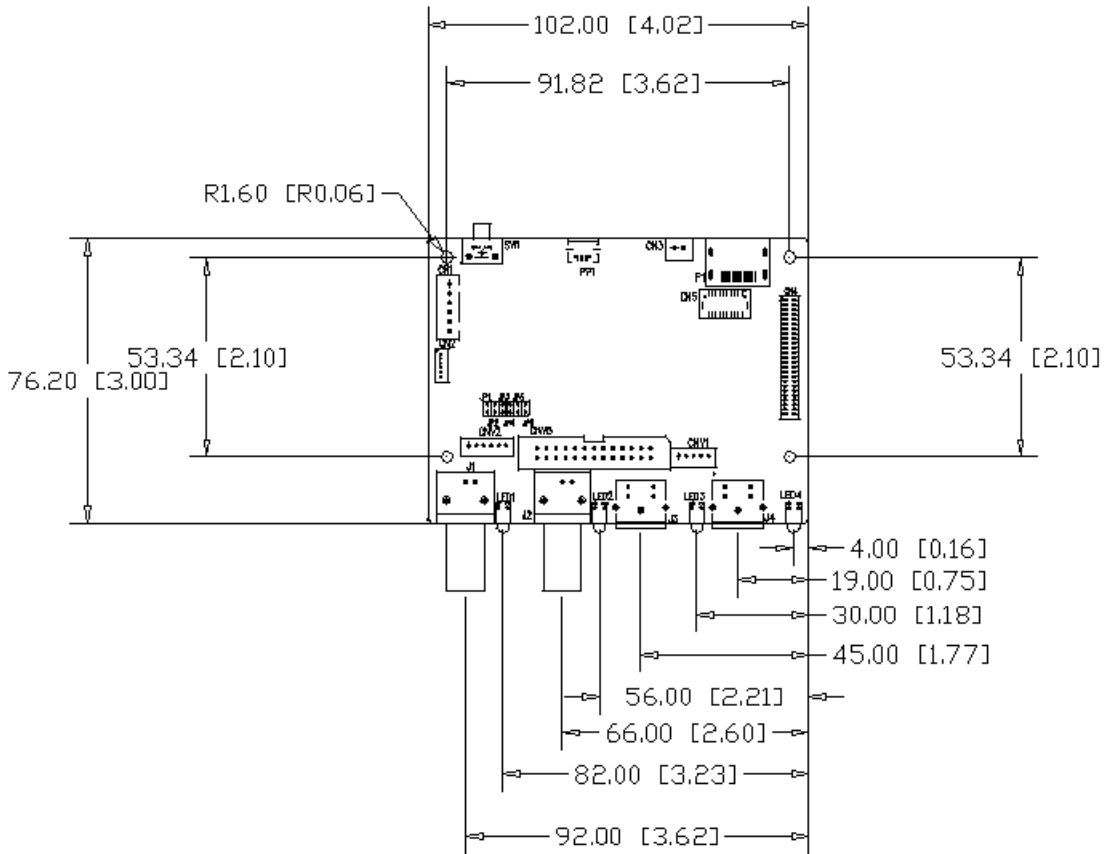

Summary for Jumper settings

Ref	Note
JP1	Reserved, keep open
JP2	Reserved, keep open
JP3	Open: enable HDMI output and disable digital video output port CN4 Close: enable digital video output port CN4 and disable HDMI output
JP4	Reserved, keep open
JP5	Reserved, keep open
JP6	Reserved, keep open

Summary of Pin Outs

CN1 – RS-232 Serial Control : JST 6-way, B6B-XH-A (Matching type : XHP-6)

Pin	Symbol	Description
1	MCU_SCL_IN	I2C slave clock in
2	MCU_SDA_IN	I2C slave data in
3	VCC	Board power supply +5V
4	TXD	RS-232 Tx data
5	GND	Ground
6	RXD	RS-232 Rx data

CN2 – Auxiliary Control : Reserved

Pin	Symbol	Description
1	PCLK	Reserved
2	PDATA	Reserved
3	Ext_SCLK	Reserved
4	Ext_SDATA	Reserved
5	GND	Ground
6	MCU_VCC	MCU power supply +3.3V

CN3 – Power Supply Socket 2 : JST 2-way, B2B-XH-A (Matching type : XHP-2)

Pin	Symbol	Description
1	VCC	Board power supply +5V
2	GND	Ground

CN4 – Digital Video Output Connector (To be supported) : 2 x 25 ways, 2.54x1.27 header
(Matching connector type : DF13-40DS-1.25C)

Pin	Symbol	Description
1	GND	Ground
2	GND	Ground
3	VD_D0	CrCb0
4	VD_D10	Y0
5	VD_D1	CrCb1
6	VD_D11	Y1
7	VD_D2	CrCb2
8	VD_D12	Y2
9	VD_D3	CrCb3
10	VD_D13	Y3
11	VD_D4	CrCb4
12	VD_D14	Y4
13	VD_D5	CrCb5
14	VD_D15	Y5
15	VD_D6	CrCb6
16	VD_D16	Y6
17	VD_D7	CrCb7
18	VD_D17	Y7
19	VD_D8	CrCb8
20	VD_D18	Y8
21	VD_D9	CrCb9
22	VD_D19	Y9
23	MCU_SDA_IN	I2C slave data in
24	MCU_SCL_IN	I2C slave clock in
25	VCC	Board power supply +5V
26	VCC	Board power supply +5V
27	VD_CLK	Video Clock

Specifications subject to change without notice

28	NC	No Connection
29	GND	Ground
30	NC	No Connection
31	VD_FIELD	Field Signal
32	NC	No Connection
33	VD_VS	Video V Sync
34	NC	No Connection
35	VD_HS	Video H Sync
36	GND	Ground
37	VD_DE	Video Data Enable
38	NC	No Connection
39	NC	No Connection
40	NC	No Connection
41	VD_LOCK	Video horizontal sync is locked
42	NC	No Connection
43	GND	Ground
44	GND	Ground
45	NC	No Connection
46	NC	No Connection
47	NC	No Connection
48	NC	No Connection
49	VIDEOMUX_CAB	Pull high to 3.3V
50	GND	Ground

CN5 – HDMI on board for internal connector: JST BM20B-SRDS (Matching type : SHDR-20V-S-B)

Pin	Symbol	Description
1	GND	Ground
2	GND	Ground
3	RXC+	TMDS Data C+
4	RXC-	TMDS Data C-
5	RX0+	TMDS Data 0+
6	RX0-	TMDS Data 0-
7	RX1+	TMDS Data 1+
8	RX1-	TMDS Data 1-
9	RX2+	TMDS Data 2+
10	RX2-	TMDS Data 2-
11	GND	Ground
12	GND	Ground
13	MSTR2_SCL	Reserved
14	MSTR2_SDA	Reserved
15	DDC_5V	+5V power supply for DDC (optional)
16	HPD	Hot plug detection
17	DDC_SCL	DDC serial clock
18	DDC_SDA	DDC Data
19	CEC	Consumer Electronics Control(CEC) pin
20	VCC2	VCC 5V output

CNV1 – Alternate Video Input : JST 5-way, B5B-PH-K (Matching type : PHR-5)

Pin	Symbol	Description
1	LUMA1	S-Video 1 chroma in
2	CHRO1	S-Video 1 luma in
3	GND	Ground
4	GND	Ground
5	CVBS1	Composite video 1 in

CNV2 – Component Video 1 Input : JST 6-way, B6B-PH-K (Matching type : PHR-6)

Pin	Symbol	Description
1	Y1	Component video 1 Y in
2	GND	Ground
3	CB1	Component video 1 Cb in
4	GND	Ground
5	CR1	Component video 1 Cr in
6	GND	Ground

CNV5 – Auxiliary Video Input Connector : Header pin 13x2

Pin	Symbol	Description
1	CHRO1	S-Video 1 chroma in
2	GND	Ground
3	LUMA1	S-Video 1 luma in
4	GND	Ground
5	CVBS1	Composite video 1 in
6	GND	Ground
7	Y1	Component video 1 Y in
8	GND	Ground
9	CB1	Component video 1 Cb in
10	GND	Ground
11	CR1	Component video 1 Cr in
12	GND	Ground
13	CHOR2	S-Video 2 chroma in
14	GND	Ground
15	LUMA2	S-Video 2 luma in
16	GND	Ground
17	CVBS2	Composite video 2 in
18	GND	Ground
19	CR2	Component video 2 Cr in
20	GND	Ground
21	Y2	Component video 2 Y in
22	GND	Ground
23	CB2	Component video 2 Cb in
24	GND	Ground
25	NC	No connection
26	GND	Ground

PP1 – Power Supply Socket 1 : Micro USB

Pin	Description
1	Micro USB Power Supply +5V
2	Reserved
3	Reserved
4	Reserved
5	Ground

Appendix I - Mode Support Table

Composite

Mode	Resolution
NTSC-M	720x480i30
NTSC-J	720x480i30
NTSC-4.43	720x480i30
PAL-BDGHI	720x576i25
PAL-M	720x480i30
PAL-Nc	720x576i25
PAL-60	720x480i30

S-Video

Mode	Resolution
NTSC-M	720x480i30
NTSC-J	720x480i30
NTSC-4.43	720x480i30
PAL-BDGHI	720x576i25
PAL-M	720x480i30
PAL-Nc	720x576i25
PAL-60	720x480i30

Component

Mode	Resolution
NTSC-M	720x480i30
NTSC-J	720x480i30
NTSC-4.43	720x480i30
PAL-M	720x480i30
PAL-60	720x480i30

Appendix II - RS-232 control protocols

RS-232 Serial control (Baud rate 2400, 8 bits, 1 stop bit and no parity)

Physical connection :

Controller side
Connector interface : CN8
Mating connector : JST XHP-6

Computer side
Connector interface : Serial port
Mating connector : DB9 Female

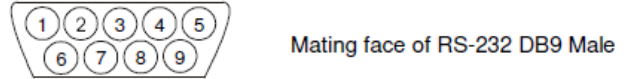

PIN#	Description
4	RS-232 Tx Data
5	Ground
6	RS-232 Rx Data

PIN#	Description
2	RS-232 Rx Data
3	RS-232 Tx Data
5	Ground

Remark :

(1) : RS-232 connection cable, 600mm P/N 426090200-3 can be ordered separately for connection.

Software connection :

The OSD function can be controlled through sending the RS-232 protocol.

The RS-232 program can be custom-made to fit for application or it can be used the serial control program, like Accessport, Telix or Serial Utility program developed by DigitalView. Please contact your local support for information.

Function	Command	Description	Acknowledge (if enabled)
Input main select	0x98, nn "+" "-" "r" "R" "?"	Select input main = PC or VIDEO or next available Reset Query	0x42,0x31 Composite 1 0x42,0x32 Composite 2 0x43,0x31 S-video1 (JP1 open) 0x43,0x32 S-video2 (JP1 open) 0x44,0x31 Component 1 0x44,0x32 Component 2

Appendix III – AVD-1000 connect with SVX-1920v3



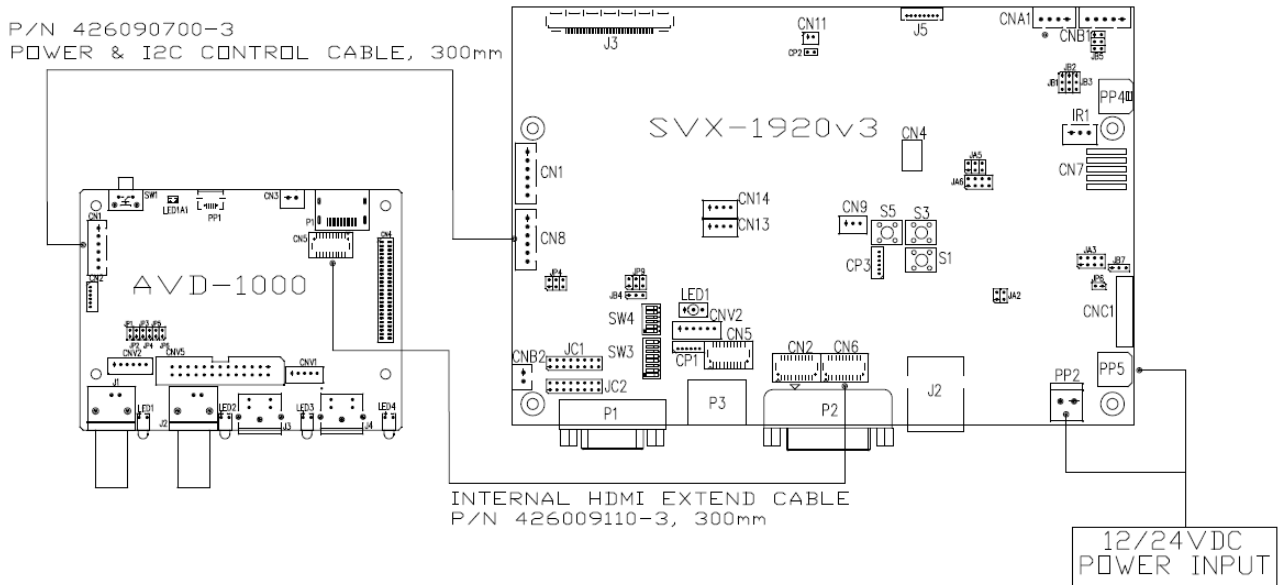



AVD-1000 & SVX-1920v3 connection* :



*Please ensure AVD-1000 should use E1.02.00 above & SVX-1920v3 should update to E.1.14.00 above.

After connected with SVX-1920v3, the menu could select the input video signal.

OSD functions

	<p>Source : Select the input video signal</p> <p>Main Port Change ▶ VGA DVI HDMI Composite 1** Composite 2** S-Video 1** S-Video 2** SD Component 1** SD Component 2** Component HD/SD SDI 1** HD/SD SDI 2**</p> <p>PIP Port change ▶ PIP Off / VGA / DVI / HDMI / Composite 1** / Composite 2** / S-Video 1** / S-Video 2** / SD Component 1** / SD Component 2** / Component / HD/SD SDI 1** / HD/SD SDI 2**</p> <p>PIP Size ▶ : Off / PIP Size 1~18 / Size by Size / Size by Size Tall The PIP capability on display input sources refer to Appendix VII – PIP mix table</p> <p>PIP Position :</p> <p> Move the PIP position upward</p> <p> Move the PIP position downward</p> <p> Move the PIP position to the left</p> <p> Move the PIP position to the right</p> <p>PIP Blend Level : 6.25% ~ 100% : PIP Transparency PIP Swap : Swap between the main window and PIP window</p> <p>PIP Auto Turn off :  : OFF / ON ON : When PIP is no signal input after 30 seconds, the PIP window will turn off automatically. OFF : PIP window keeps on ++ DISPLAY WHEN HD-1000/-2000/-3000S CONNECTED ** DISPLAY WHEN AVD-1000 CONNECTED</p>
---	--

WARRANTY

The products are warranted against defects in workmanship and material for a period of three (3) year from the date of purchase provided no modifications are made to it and it is operated under normal conditions and in compliance with the instruction manual.

The warranty does not apply to:

- Product that has been installed incorrectly, this specifically includes but is not limited to cases where electrical short circuit is caused.
- Product that has been altered or repaired except by the manufacturer (or with the manufacturer's consent).
- Product that has subjected to misuse, accidents, abuse, negligence or unusual stress whether physical or electrical.
- Ordinary wear and tear.

Except for the above express warranties, the manufacturer disclaims all warranties on products furnished hereunder, including all implied warranties of merchantability and fitness for a particular application or purpose. The stated express warranties are in lieu of all obligations or liabilities on the part of the manufacturer for damages, including but not limited to special, indirect consequential damages arising out of or in connection with the use of or performance of the products.

CAUTION

Whilst care has been taken to provide as much detail as possible for use of this product it cannot be relied upon as an exhaustive source of information. This product is for use by suitably qualified persons who understand the nature of the work they are doing and are able to take suitable precautions and design and produce a product that is safe and meets regulatory requirements.

LIMITATION OF LIABILITY

The manufacturer's liability for damages to customer or others resulting from the use of any product supplied hereunder shall in no event exceed the purchase price of said product.

TRADEMARKS

The following are trademarks of Digital View Ltd:

- Digital View
- AVD-1000/HVD-1000

CONTACT DETAILS

Digital View has offices in Asia, Europe and USA :

USA

Digital View Inc.
18440 Technology Drive
Building 130
Morgan Hill,
California, 95037
USA

Tel: (1) 408-782 7773 **Fax:** (1) 408-782 7883

Sales: ussales@digitalview.com

EUROPE

Digital View Ltd.
The Lake House
Knebworth Park
Herts, SG3 6PY
UK

Tel: +44-(0)20-7631-2150 **Fax:** +44-(0)20-7631-2156

Sales: uksales@digitalview.com

ASIA

Digital View Ltd
2nd Floor Bamboos Center
52 Hung To Road
Kwun Tong
Hong Kong

Tel: (852) 2861 3615 **Fax:** (852) 2520 2987

Sales: hksales@digitalview.com

WEBSITE

www.digitalview.com

Revision History

Date	Rev No.	Page	Summary
8 April 2015	1.00	All	First issued
20 May 2015	1.10	All	Add support mode