



145 Royal Crest Court Unit 42 Markham, ON, Canada L3R 9Z4  
Tel: 905-477-1166 Fax: 905-477-1782 <http://www.orientdisplay.com>

## SPECIFICATION FOR LCM MODULE

MODULE NO.: AVD-T320240C16B-A03  
DOC. REVISION00

Customer Approval:

--

	SIGNATURE	DATE
PREPARED BY (RD ENGINEER)		
PREPARED BY (QA ENGINEER)		
CHECKED BY		
APPROVED BY		

**DOCUMENT REVISION HISTORY**

Version	DATE	DESCRIPTION	CHANGED BY
00	2010-08-30	First issue	

## CONTENTS

1. Functions & Features	2
2. Mechanical specifications	2
3. Block diagram	2
4. Dimensional Outline	3
5. Pin description	4
6. Maximum absolute limit	4
7. Electrical characteristics	5
8. Electro-Optical characteristics	5
9. Timing Characteristics	6
10. Control and Display Instruction	7-9
11. Quality Specifications	10-18

## 1. Functions & Features

1.1. Format	: 320x240 Dots
1.2. LCD mode	: Transmissive
1.3. Viewing direction	: 6 O'clock
1.4. Display color	: 65536 colors
1.5. Operation temp	: -20~70 °C
1.6. Storage temp	: -30~80 °C
1.7. Power supply voltage (V <sub>DD</sub> )	: 3.3V
1.8. LED power voltage	: 3.3V
1.9. Backlight color	: White(LED)
1.10 LCM Contrast ratio	: 300:1
1.11 LCM Brightness	: 200 nit(tye)
1.12.RoHS standard	

## 2. MECHANICAL SPECIFICATIONS

2.1. Module size	: 92.0mm(L)*78.4mm(W)*10.5( Max) mm (H)
2.2. Viewing area	: 73.3mm(L)*55.8mm(W)
2.3. Pixel size	: 73.0um(W)*219.0um(H)
2.4. Weight	: Approx.

## 3. BLOCK DIAGRAM

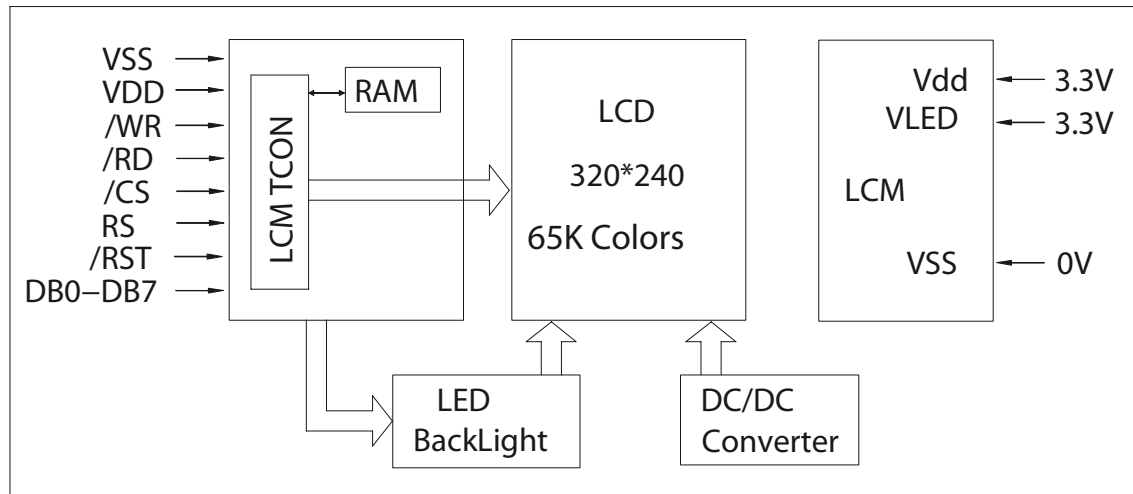

Figure 1. Block diagram

# 4. DIMENSIONAL OUTLINE

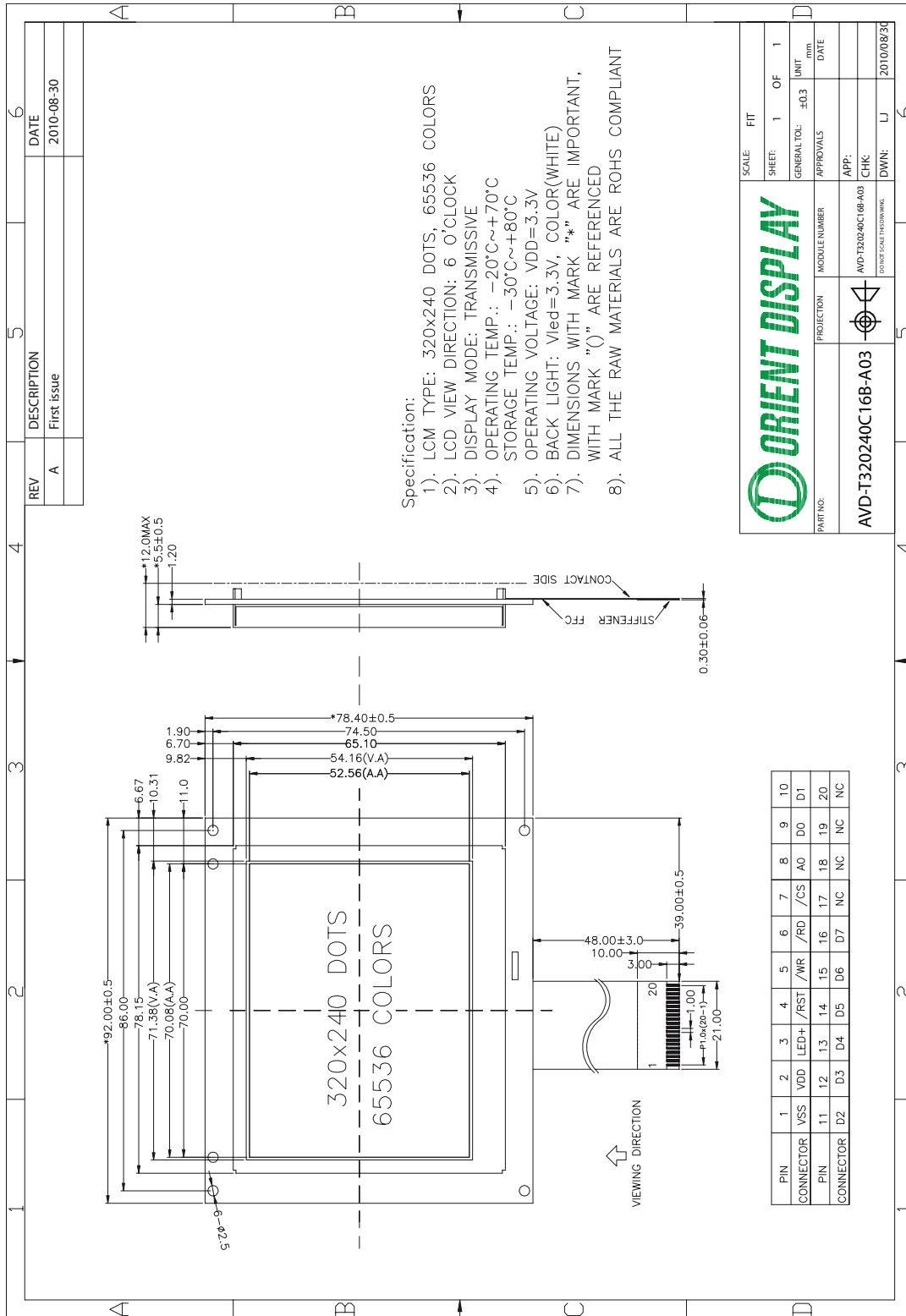

Figure 2 Dimensional outline

## 5. PIN DESCRIPTION

No.	Symbol	Function
1	VSS	GND
2	VDD	Logic supply voltage (3.3V)
3	LED+	Power supply for backlight(+3.3V)
4	/RST	Reset signal (L)
5	/WR	Write signal
6	/RD	Read signal
7	/CS	Chip enable signal
8	A0	Register selection (H:Data register, L:Instruction register)
9	D0	Data bus line
10	D1	Data bus line
11	D2	Data bus line
12	D3	Data bus line
13	D4	Data bus line
14	D5	Data bus line
15	D6	Data bus line
16	D7	Data bus line
17	NC	---
18	NC	---
19	NC	---
20	NC	---

## 6. MAXIMUM ABSOLUTE LIMIT

Item	Symbol	MIN	MAX	Unit
Supply Voltage for Logic	$V_{DD}$	-0.3	3.6	V
Input Voltage	$V_{in}$	-0.3	$V_{DD}+0.3$	V
Supply Current (With Led Backlight)	$I_{DD}(T_a = 25^{\circ}C)$	---	95	mA
Operating Temperature	Top	-20	70	°C
Storage Temperature	Tst	-30	80	°C

## 7. ELECTRICAL CHARACTERISTICS

Item	Symbol	Condition	Min	Typ	Max	Unit
Supply Voltage for Logic	$V_{DD}-V_{SS}$	$T_a = 25^\circ\text{C}$	3.0	3.3	3.6	V
Input High Voltage	$V_{IH}$	$T_a = 25^\circ\text{C}$	$0.8V_{DD}$	---	$V_{DD}$	V
Input Low Voltage	$V_{IL}$	$T_a = 25^\circ\text{C}$	0	---	$0.2V_{DD}$	V
Output High Voltage	$V_{OH}$	$T_a = 25^\circ\text{C}$	$0.8V_{DD}$	---	$V_{DD}$	V
Output Low Voltage	$V_{OL}$		0	---	$0.2V_{DD}$	V
Supply Current (Led Backlight off )	$I_{DD}$	$T_a = 25^\circ\text{C}$	---	65	--	mA
Supply Current (Led Backlight on )	$I_{dd}$	$T_a = 25^\circ\text{C}$	---	90	---	mA
Luminous Intensity (With LCD dots off)	$I_V$	$V_{led}=5.0$ V	150	200	---	$\text{Cd}/\text{m}^2$
LED Backlight Color	White					

Item	Symbol	Condition	Min	Typ	Max	Unit
LED Life time	---	$T_a = 25^\circ\text{C}$ Humidity: 70% below Forward Current: 20mA	---	50,000	---	Hr

## 8. ELECTRO-OPTICAL CHARACTERISTICS

( $V_{DD}=3.3\text{V}, V_{led}=5.0\text{V}, T_a = 25^\circ\text{C}$ )

Item	Symbol	Condition	Min	Typ	Max	Unit
Viewing angle ( $CR \geq 10$ )	$\theta_L$	$=180^\circ$ (9 o'clock)	45	60	---	degree
	$\theta_R$	$=0^\circ$ (3 o'clock)	45	60	---	
	$\theta_T$	$=90^\circ$ (12 o'clock)	35	50	---	
	$\theta_B$	$=270^\circ$ (6 o'clock)	40	55	---	
Response time	$T_{on}$	Normal $\theta = 0^\circ$	---	10	20	ms
	$T_{off}$		---	15	25	ms
Contrast ratio	$Cr$		150	300	---	---
Luminance	$L1$		150	200		$\text{Cd}/\text{m}^2$

$$Cr = \frac{\text{Brightness of non-selected segment}(B2)}{\text{Brightness of selected segment}(B1)}$$

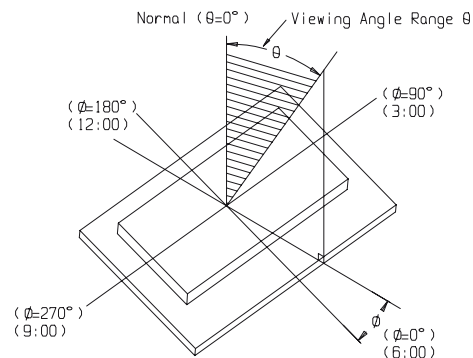
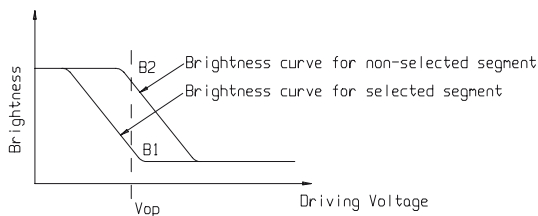

## 9. TIMING CHARACTERISTICS

### 9.1 Interface Timing

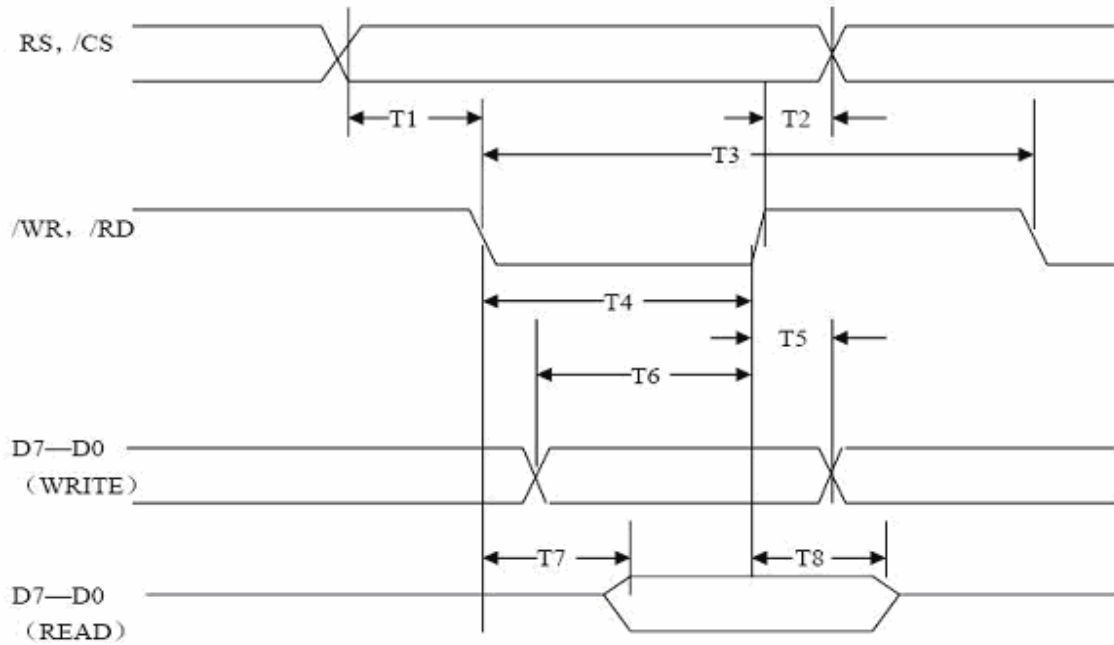

Figure 4. 8080 family Interface Timing

### 9.2 MCU Interface

Signal	Symbol	Parameter	VDD=33V		Unit	Condition
			Min	Max		
RS,/CS	T2	Address hold time	10	-	ns	CL=100p F
	T1	Address setup time	0	-	ns	
/WR,/RD	T3	System cycle time	320	-	ns	
	T4	Strobe pulsewidth	160	-	ns	
D0-D7	T5	Data hold time	80	-	ns	
	T6	Data setup time	120	-	ns	
	T7	/RD Access time	-	50	ns	
	T8	Output disable time	10	50	ns	



## 10. CONTROL AND DISPLAY INSTRUCTION

### 10.1 Instruction

Command (Hex)	Command Code										Function		
	/CS	RS	/WR	/RD	D7	D6	D5	D4	D3	D2		D1	D0
0x80	0	0	0	1	1	0	0	0	0	0	0	0	Display on glayer1 Read and Write on glayer1
0x81	0	0	0	1	1	0	0	0	0	0	0	1	Display and Read on glayer1 Write on glayer2
0x82	0	0	0	1	1	0	0	0	0	0	1	0	Display and Write on glayer1 Read on glayer2
0x83	0	0	0	1	1	0	0	0	0	0	1	1	Display on glayer1 Write and Read on glayer2
0x84	0	0	0	1	1	0	0	0	0	1	0	0	Display on glayer2 Read and Write on glayer1
0x85	0	0	0	1	1	0	0	0	0	1	0	1	Display and Write on glayer2 Read on glayer1
0x86	0	0	0	1	1	0	0	0	0	1	1	0	Display and Read on glayer2 Write on glayer1
0x87	0	0	0	1	1	0	0	0	0	1	1	1	Display on glayer2 Write and Read on glayer2
0x90	0	0	0	1	1	0	0	1	0	0	0	0	Black light off
0x91	0	0	0	1	1	0	0	1	0	0	0	1	Black light on
0xa0	0	0	0	1	1	0	1	0	0	0	0	0	Mix Mode off (Single layer display)
0xa1	0	0	0	1	1	0	1	0	0	0	0	1	Mix Mode 1 (Front: glay1, Rear: glay2) (Figure 5.)
0xa2	0	0	0	1	1	0	1	0	0	0	1	0	Mix Mode 2 (Front: glay2, Rear: glay1) (Figure 6.)
0xa3	0	0	0	1	1	0	1	0	0	0	1	1	Mix Mode 3 (Mix glay1 and glay2) (Figure 7.)
0xfc	0	0	0	1	1	1	1	1	1	1	0	0	display on
0xfd	0	0	0	1	1	1	1	1	1	1	0	1	display off
Address set X(0~319) Y(0~240)	0	0	0	1	0	0	0	0	0	0	0	---	Write X Addresss(H)
	0	0	0	1	---	---	---	---	---	---	---	---	Write X Addresss(L)
	0	0	0	1	---	---	---	---	---	---	---	---	Write Y Addresss
Write data	0	1	0	1	---	---	---	---	---	---	---	---	Write display data
Read data	0	1	1	0	---	---	---	---	---	---	---	---	Read display data

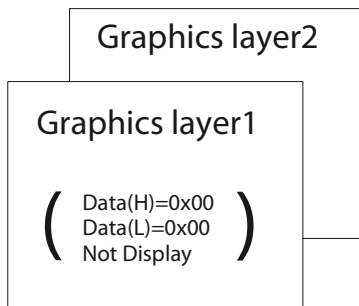

Figure 5.

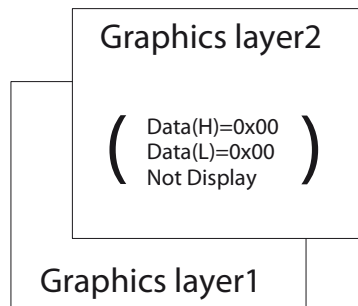

Figure 6.

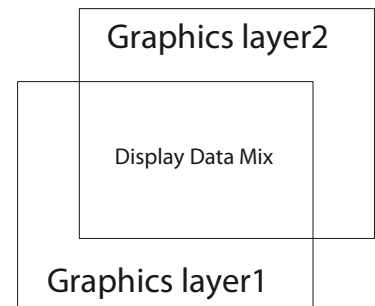

Figure 7.

## 10.2 Display Data format( RGB565 65K Colors)

Display data(H)										Display data(L)					
MSB					LSB					MSB			LSB		
D7	D6	D5	D4	D3	D2	D1	D0	D7	D6	D5	D4	D3	D2	D1	D0
R4	R3	R2	R1	R0	G5	G4	G3	G2	G1	G0	B4	B3	B2	B1	B0
MSB RED (00000~11111)					MSB GREEN (000000~111110)					MSB BLUE (00000~11111)					

Note: Continuum write display data, Address is increased by 1 automatically.

## 10.3 Program Example

```
// VDD=3.3V Vled=3.3V
#include <reg51.h>
#define uint unsigned int
#define uchar unsigned char

sbit CS   = P3^2;
sbit RS   = P3^3;
sbit WRR  = P3^4;
sbit RDD  = P3^5;
sbit RST  = P3^6;

void wcomd(uchar ch)
{
    RDD=1;RS=0; CS=0;
    P1=ch;
    WRR=0;
    WRR=1;
    CS=1;
}

void wdata(uchar ch)
{
    RDD=1;RS=1; CS=0;
    P1=ch;
    WRR=0;
    WRR=1;
    CS=1;
}

unsigned char rdata(void)
{
    uchar ch;
    WRR=1;RS=1; CS=0;
    P1=0xff;
    RDD=0;
    ch=P1;
    RDD=1;
    CS=1;
    return(ch);
}
```

```

}

void waddr(uint xdat,uint ydat)
{
  uint xxh,xxl;
  xxh=xdat/256;
  xxl=xdat%256;
  wcomd(xxh);
  wcomd(xxl);
  wcomd(ydat);
}

void initial_tft()
{
  wcomd(0x91);          //led light on
  wcomd(0xfc);         //display on
  wcomd(0xa0);         //mix mode off
}

void disp_all(uchar xsdath, uchar xsdatl)
{
  uint j,k;
  waddr(0x00,0x00);
  for(k=0;k<240;k++)
  {
    for(j=0;j<320;j++)
    {
      wdata(xsdath);
      wdata(xsdatl);
    }
  }
}

void main(void)
{
  RST=0;delay(50);RST=1;delay(20);
  initial_tft();
  while(1)
  {
    wcomd(0x80);          //display glayer1 (0x80~0x83)
    disp_all(0xff,0xff); delay(200); //white
    disp_all(0x00,0x00); delay(200); //black
    disp_all(0xf8,0x00); delay(200); //red
    disp_all(0x07,0xe0); delay(200); //green
    disp_all(0x00,0x1f); delay(200); //blue
    .....
  }
}

```

## 11.QUALITY SPECIFICATIONS

### 11.1 Standard of the product appearance test

Manner of appearance test: This inspection should be performed in using 20W x 2 fluorescent lamps. Distance between LCM and fluorescent lamps should be 100 cm or more. Distance between LCM and inspector eyes should be 30 cm or more.

Viewing direction for inspection is 45° from vertical against LCM.

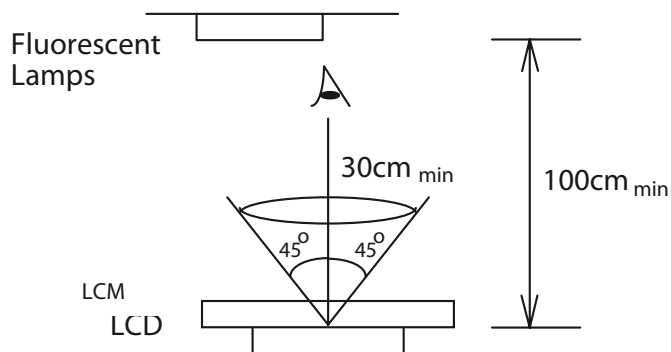

Definition of zone:

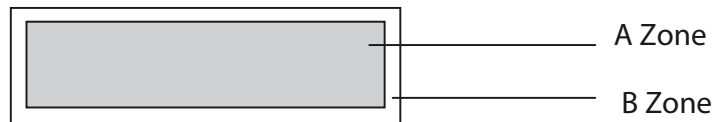

A Zone: Active display area (minimum viewing area).

B Zone: Non-active display area (outside viewing area).

### 11.2 Specification of quality assurance

AQL inspection standard

Sampling method: MIL-STD-105E, Level II, single sampling

Defect classification (Note: \* is not including)

Classify	Item		Note	AQL
Major	Display state	Short or open circuit	1	0.65
		LC leakage		
		Flickering		
		No display		
		Wrong viewing direction		
		Contrast defect (dim, ghost)	2	
		Back-light	1,8	
	Non-display	Flat cable or pin reverse	10	
Wrong or missing component		11		
Minor	Display state	Background color deviation	2	1.0
		Black spot and dust	3	
		Line defect, Scratch	4	
		Rainbow	5	
		Chip	6	
		Pin hole	7	
	Polarizer	Protruded	12	
		Bubble and foreign material	3	
	Soldering	Poor connection	9	
	Wire	Poor connection	10	
	TAB	Position, Bonding strength	13	

Note on defect classification

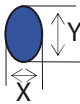
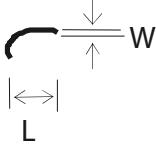
No.	Item	Criterion																				
1	Short or open circuit	Not allow																				
	LC leakage																					
	Flickering																					
	No display																					
	Wrong viewing direction																					
	Wrong Back-light																					
2	Contrast defect	Refer to approval sample																				
	Background color deviation																					
3	Point defect, Black spot, dust (including Polarizer)  $\varphi = (X+Y)/2$	 <table border="1" data-bbox="917 913 1343 1205"> <thead> <tr> <th>Point Size</th> <th>Acceptable Qty.</th> </tr> </thead> <tbody> <tr> <td><math>\varphi \leq 0.10</math></td> <td>Disregard</td> </tr> <tr> <td><math>0.10 &lt; \varphi \leq 0.20</math></td> <td>3</td> </tr> <tr> <td><math>0.20 &lt; \varphi \leq 0.25</math></td> <td>2</td> </tr> <tr> <td><math>0.25 &lt; \varphi \leq 0.30</math></td> <td>1</td> </tr> <tr> <td><math>\varphi &gt; 0.30</math></td> <td>0</td> </tr> </tbody> </table> <p style="text-align: right;">Unit: mm</p>	Point Size	Acceptable Qty.	$\varphi \leq 0.10$	Disregard	$0.10 < \varphi \leq 0.20$	3	$0.20 < \varphi \leq 0.25$	2	$0.25 < \varphi \leq 0.30$	1	$\varphi > 0.30$	0								
Point Size	Acceptable Qty.																					
$\varphi \leq 0.10$	Disregard																					
$0.10 < \varphi \leq 0.20$	3																					
$0.20 < \varphi \leq 0.25$	2																					
$0.25 < \varphi \leq 0.30$	1																					
$\varphi > 0.30$	0																					
4	Line defect, Scratch	 <table border="1" data-bbox="849 1370 1385 1630"> <thead> <tr> <th colspan="2">Line</th> <th>Acceptable Qty.</th> </tr> <tr> <th>L</th> <th>W</th> <th></th> </tr> </thead> <tbody> <tr> <td>---</td> <td><math>0.015 \geq W</math></td> <td>Disregard</td> </tr> <tr> <td><math>5.0 \geq L</math></td> <td><math>0.03 \geq W</math></td> <td rowspan="2">2</td> </tr> <tr> <td><math>5.0 \geq L</math></td> <td><math>0.05 \geq W</math></td> </tr> <tr> <td><math>5.0 \geq L</math></td> <td><math>0.1 &gt; W</math></td> <td>1</td> </tr> <tr> <td>---</td> <td><math>0.05 &lt; W</math></td> <td>Applied as point defect</td> </tr> </tbody> </table> <p style="text-align: right;">Unit: mm</p>	Line		Acceptable Qty.	L	W		---	$0.015 \geq W$	Disregard	$5.0 \geq L$	$0.03 \geq W$	2	$5.0 \geq L$	$0.05 \geq W$	$5.0 \geq L$	$0.1 > W$	1	---	$0.05 < W$	Applied as point defect
Line		Acceptable Qty.																				
L	W																					
---	$0.015 \geq W$	Disregard																				
$5.0 \geq L$	$0.03 \geq W$	2																				
$5.0 \geq L$	$0.05 \geq W$																					
$5.0 \geq L$	$0.1 > W$	1																				
---	$0.05 < W$	Applied as point defect																				
5	Rainbow	Not more than two color changes across the viewing area.																				

No	Item	Criterion																																	
6	<p data-bbox="284 369 347 405">Chip</p> <p data-bbox="284 472 392 508">Remark:</p> <p data-bbox="336 508 469 577">X: Length direction</p> <p data-bbox="336 595 469 665">Y: Short direction</p> <p data-bbox="336 683 497 752">Z: Thickness direction</p> <p data-bbox="336 770 497 840">t: Glass thickness</p> <p data-bbox="336 857 497 927">W: Terminal Width</p>	<div data-bbox="598 414 965 593"> </div> <p data-bbox="986 405 1252 441">Acceptable criterion</p> <table border="1" data-bbox="986 443 1369 524"> <thead> <tr> <th>X</th> <th>Y</th> <th>Z</th> </tr> </thead> <tbody> <tr> <td><math>\leq 2</math></td> <td>0.5mm</td> <td><math>\leq t/2</math></td> </tr> </tbody> </table> <div data-bbox="582 728 933 907"> </div> <p data-bbox="975 705 1241 741">Acceptable criterion</p> <table border="1" data-bbox="975 743 1369 824"> <thead> <tr> <th>X</th> <th>Y</th> <th>Z</th> </tr> </thead> <tbody> <tr> <td><math>\leq 3</math></td> <td>0.5mm</td> <td><math>\leq t</math></td> </tr> </tbody> </table> <div data-bbox="582 974 933 1198"> </div> <p data-bbox="986 987 1257 1023">Acceptable criterion</p> <table border="1" data-bbox="986 1025 1369 1151"> <thead> <tr> <th>X</th> <th>Y</th> <th>Z</th> </tr> </thead> <tbody> <tr> <td><math>\leq 3</math></td> <td><math>\leq 2</math></td> <td><math>\leq t</math></td> </tr> <tr> <td colspan="2">shall not reach to ITO</td> <td></td> </tr> </tbody> </table> <div data-bbox="582 1332 965 1512"> </div> <p data-bbox="975 1355 1241 1391">Acceptable criterion</p> <table border="1" data-bbox="975 1393 1369 1473"> <thead> <tr> <th>X</th> <th>Y</th> <th>Z</th> </tr> </thead> <tbody> <tr> <td>Disregard</td> <td><math>\leq 0.2</math></td> <td><math>\leq t</math></td> </tr> </tbody> </table> <div data-bbox="582 1624 933 1803"> </div> <p data-bbox="975 1641 1241 1677">Acceptable criterion</p> <table border="1" data-bbox="975 1680 1337 1760"> <thead> <tr> <th>X</th> <th>Y</th> <th>Z</th> </tr> </thead> <tbody> <tr> <td><math>\leq 5</math></td> <td><math>\leq 2</math></td> <td><math>\leq t/3</math></td> </tr> </tbody> </table>	X	Y	Z	$\leq 2$	0.5mm	$\leq t/2$	X	Y	Z	$\leq 3$	0.5mm	$\leq t$	X	Y	Z	$\leq 3$	$\leq 2$	$\leq t$	shall not reach to ITO			X	Y	Z	Disregard	$\leq 0.2$	$\leq t$	X	Y	Z	$\leq 5$	$\leq 2$	$\leq t/3$
X	Y	Z																																	
$\leq 2$	0.5mm	$\leq t/2$																																	
X	Y	Z																																	
$\leq 3$	0.5mm	$\leq t$																																	
X	Y	Z																																	
$\leq 3$	$\leq 2$	$\leq t$																																	
shall not reach to ITO																																			
X	Y	Z																																	
Disregard	$\leq 0.2$	$\leq t$																																	
X	Y	Z																																	
$\leq 5$	$\leq 2$	$\leq t/3$																																	

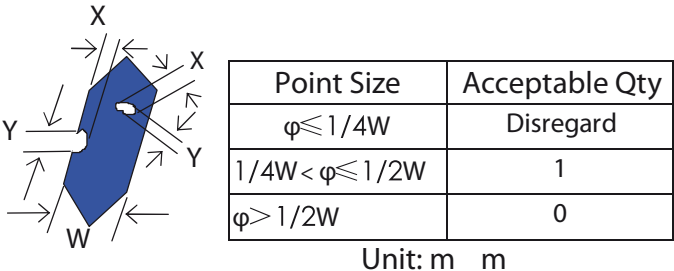
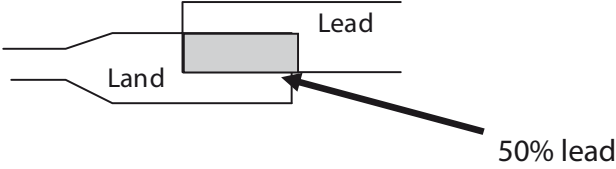
No.	Item	Criterion								
7	Segment pattern $W = \text{Segment width}$ $\phi = (X+Y)/2$	(1) Pin hole $\phi < 0.10\text{mm}$ is acceptable.  <table border="1" data-bbox="911 568 1359 748"> <thead> <tr> <th>Point Size</th> <th>Acceptable Qty</th> </tr> </thead> <tbody> <tr> <td><math>\phi \leq 1/4W</math></td> <td>Disregard</td> </tr> <tr> <td><math>1/4W &lt; \phi \leq 1/2W</math></td> <td>1</td> </tr> <tr> <td><math>\phi &gt; 1/2W</math></td> <td>0</td> </tr> </tbody> </table> Unit: m m	Point Size	Acceptable Qty	$\phi \leq 1/4W$	Disregard	$1/4W < \phi \leq 1/2W$	1	$\phi > 1/2W$	0
Point Size	Acceptable Qty									
$\phi \leq 1/4W$	Disregard									
$1/4W < \phi \leq 1/2W$	1									
$\phi > 1/2W$	0									
8	Back-light	(1) The color of backlight should correspond its specification. (2) Not allow flickering								
9	Soldering	(1) Not allow heavy dirty and solder ball on PCB. (The size of dirty refer to point and dust defect) (2) Over 50% of lead should be soldered on Land. 								
10	Wire	(1) Copper wire should not be rusted (2) Not allow crack on copper wire connection. (3) Not allow reversing the position of the flat cable. (4) Not allow exposed copper wire inside the flat cable.								
11*	PCB	(1) Not allow screw rust or damage. (2) Not allow missing or wrong putting of component.								

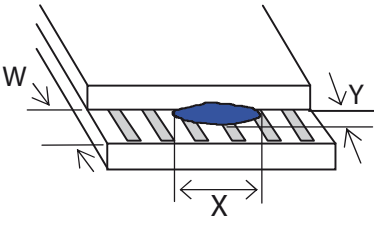
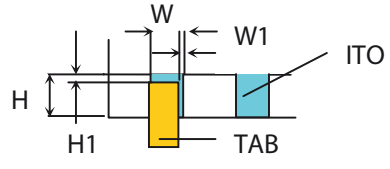
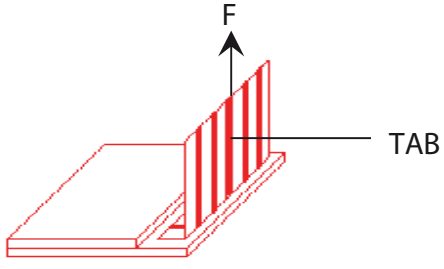

No	Item	Criterion
12	Protruded W: Terminal Width	 <p>Acceptable criteria:  <math>Y \leq 0.4</math></p>
13	TAB	<p>1. Position</p>  <div style="border: 1px solid black; padding: 5px; width: fit-content; margin-left: auto; margin-right: auto;"> <math>W1 \leq 1/3W</math>  <math>H1 \leq 1/3H</math> </div> <p>2 TAB bonding strength test</p>  <p> <math>P (=F/TAB \text{ bonding width}) \geq 650\text{gf/cm}</math>, (speed rate: 1mm/min)            5pcs per SOA (shipment)         </p>
14	Total no. of acceptable Defect	<p>A. Zone</p> <p>Maximum 2 minor non-conformities per one unit.            Defect distance: each point to be separated over 10mm</p> <p>B. Zone</p> <p>It is acceptable when it is no trouble for quality and assembly in customer's end product.</p>

### 11.3 Reliability of LCM

Reliability test condition:

Item	Condition	Time (hrs)	Assessment
High temp. Storage	80°C	48	No abnormalities in functions and appearance
High temp. Operating	70°C	48	
Low temp. Storage	-30°C	48	
Low temp. Operating	-20°C	48	
Humidity	40°C/ 90%RH	48	
Temp. Cycle	-20°C ← 25°C → 70°C (30 min ← 5 min → 30min)	10cycles	

Recovery time should be 24 hours minimum. Moreover, functions, performance and appearance ,etc. shall be free from remarkable deterioration within 50,000 hours under ordinary operating and storage conditions room temperature ( $20 \pm 8^\circ\text{C}$ ), normal humidity (below  $45 \pm 20\%$  RH), and in the area not exposed to direct sun light. The life time is not content the life time of the LED (for the life time of LED which decay only 50%,in the industry the experience value is 50000 hours, but there are not any experimentation data to support this). .

### 11.4 Precaution for using LCD/LCM

LCD/LCM is assembled and adjusted with a high degree of precision. Do not attempt to make any alteration or modification. The followings should be noted.

General Precautions:

1. LCD panel is made of glass. Avoid excessive mechanical shock or applying strong pressure onto the surface of display area.
2. The polarizer used on the display surface is easily scratched and damaged. Extreme care should be taken when handling. To clean dust or dirt off the display surface, wipe gently with cotton, or other soft material soaked with isopropyl alcohol, ethyl alcohol or trichlorotrifluoroethane, do not use water, ketone or aromatics and never scrub hard.
3. Do not tamper in any way with the tabs on the metal frame.
4. Do not make any modification on the PCB without consulting Orient Display.

5. When mounting a LCM, make sure that the PCB is not under any stress such as bending or twisting. Elastomer contacts are very delicate and missing pixels could result from slight dislocation of any of the elements.
6. Avoid pressing on the metal bezel, otherwise the elastomer connector could be deformed and lose contact, resulting in missing pixels and also cause rainbow on the display.
7. Be careful not to touch or swallow liquid crystal that might leak from a damaged cell. Any liquid crystal adheres to skin or clothes, wash it off immediately with soap and water.

#### Static Electricity Precautions:

1. CMOS-LSI is used for the module circuit; therefore operators should be grounded whenever he/she comes into contact with the module.
2. Do not touch any of the conductive parts such as the LSI pads; the copper leads on the PCB and the interface terminals with any parts of the human body.
3. Do not touch the connection terminals of the display with bare hand; it will cause disconnection or defective insulation of terminals.
4. The modules should be kept in anti-static bags or other containers resistant to static for storage.
5. Only properly grounded soldering irons should be used.
6. If an electric screwdriver is used, it should be grounded and shielded to prevent sparks.
7. The normal static prevention measures should be observed for work clothes and working benches.
8. Since dry air is inductive to static, a relative humidity of 50-60% is recommended.

#### Soldering Precautions:

1. Soldering should be performed only on the I/O terminals.
2. Use soldering irons with proper grounding and no leakage.
3. Soldering temperature:  $280^{\circ}\text{C} \pm 10^{\circ}\text{C}$
4. Soldering time: 3 to 4 second.
5. Use eutectic solder with resin flux filling.
6. If flux is used, the LCD surface should be protected to avoid spattering flux.
7. Flux residue should be removed.

#### Operation Precautions:

1. The viewing angle can be adjusted by varying the LCD driving voltage  $V_o$ .
2. Since applied DC voltage causes electro-chemical reactions, which deteriorate the display, the applied pulse waveform should be a symmetric waveform such that no DC component remains. Be sure to use the specified operating voltage.
3. Driving voltage should be kept within specified range; excess voltage will shorten display life.
4. Response time increases with decrease in temperature.
5. Display color may be affected at temperatures above its operational range.

## Limited Warranty

Orient Display LCDs and modules are not consumer products, but may be incorporated by OD's customers into consumer products or components thereof, Orient Display does not warrant that its LCDs and components are fit for any such particular purpose.

1. The liability of Orient Display is limited to repair or replacement on the terms set forth below. Orient Display will not be responsible for any subsequent or consequential events or injury or damage to any personnel or user including third party personnel and/or user. Unless otherwise agreed in writing between Orient Display and the customer, Orient Display will only replace or repair any of its LCD which is found defective electrically or visually when inspected in accordance with Orient Display general LCD inspection standard. (Copies available on request)
2. No warranty can be granted if any of the precautions state in handling liquid crystal display above has been disregarded. Broken glass, scratches on polarizer mechanical damages as well as defects that are caused accelerated environment tests are excluded from warranty.
3. In returning the LCD/LCM, they must be properly packaged; there should be detailed description of the failures or defect.