

200mA 1-Wire Configurable Front Flash LED Driver with Ultra Small Package

FEATURES

- Front Flash LED Driving
- 200mA Maximum Flash Current
- 16 Steps Current 1-wire Pulse Configurable, 12.5mA/step
- LED Current Accuracy: $\pm 15\%$
- Low Dropout Voltage: 65mV@200mA (Typ.)
- Efficiency: 94% ($V_{IN}=3.6V$, $V_F=3.4V$)
- Shutdown Current: $<0.1\mu A$
- Ultra Small $1.5 \times 1.0 \times 0.55\text{mm}^3$ DFN-6L Package

APPLICATION

- Front Camera Flash
- LED Torch Mode

GENERAL DESCRIPTION

AW3640 is a low voltage-drop current sink LED driver, which supports both Torch and Flash modes. The current-regulation sink integrated in the chip make the LED current capable of keeping constant when input voltage, LED forward voltage or temperature changing. The LED current can be adjusted among 16 steps by sending 1-wire pulse into the EN pin, and the maximum value is 200mA.

AW3640 is available in an ultra small $1.5\text{mm} \times 1.0\text{mm} \times 0.55\text{mm}$ DFN-6L package. And only one multi-layer ceramic capacitor is needed for the peripheral of the solution.

In shut down mode, AW3640 turns off all internal circuit and the consumption is less than $0.1\mu A$.

The device requires 2.8V~5.5V input voltage range and an operating temperature range of $-40\sim 85^\circ\text{C}$.

TYPICAL APPLICATION CIRCUIT

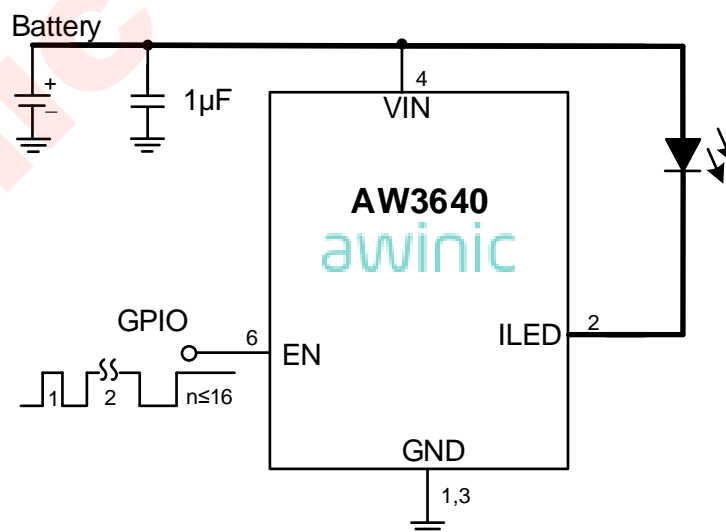
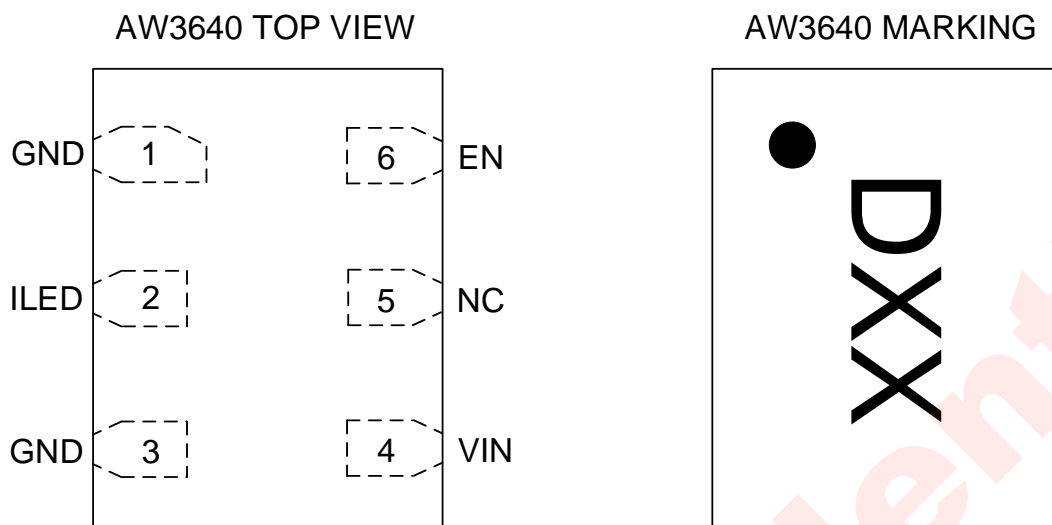

Figure 1 AW3640 Application Circuit for Single LED

All the trademarks mentioned in the document are the property of their owners.

PIN CONFIGURATION AND TOP MARK



D ---- AW3640DNR
XX ---- Manufacture trace code

PIN DEFINITION

No.	NAME	DESCRIPTION
1	GND	Ground.
2	ILED	Open drain current sink pin, connected to LED cathode.
3	GND	Ground.
4	VIN	Power Supply (2.8V-5.5V)
5	NC	Not connected.
6	EN	Enable pin. LED current can be adjusted by sending 1-wire pulse into this pin.

ORDERING INFORMATION

Part Number	Temperature	Package	Moisture Sensitivity Level	Environmental Information	Marking	Delivery Form
AW3640 DNR	-40°C ~ 85°C	1.5mmx1.0mm DFN-6L	MSL1	ROHS+HF	DXX	Tape and Reel 3000pcs/Reel

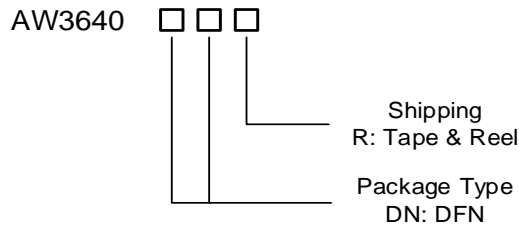

TYPICAL APPLICATION CIRCUITS

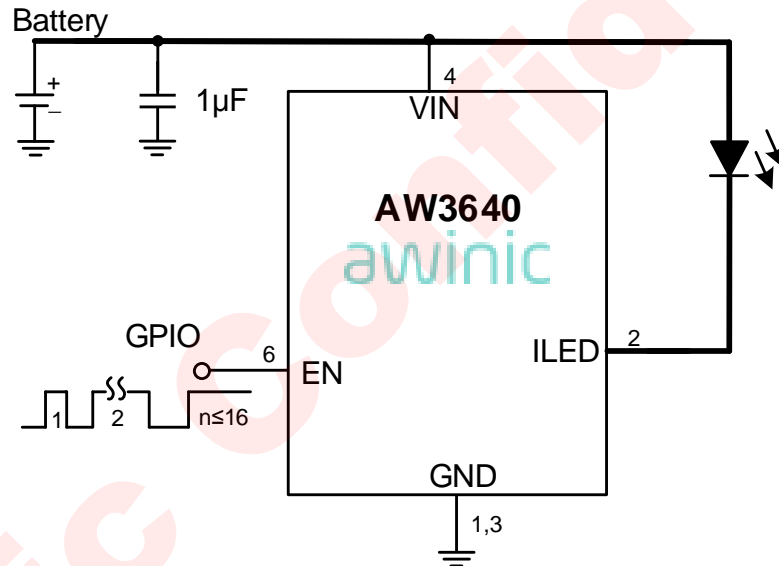

Figure 2 AW3640 Application Circuit for Single LED

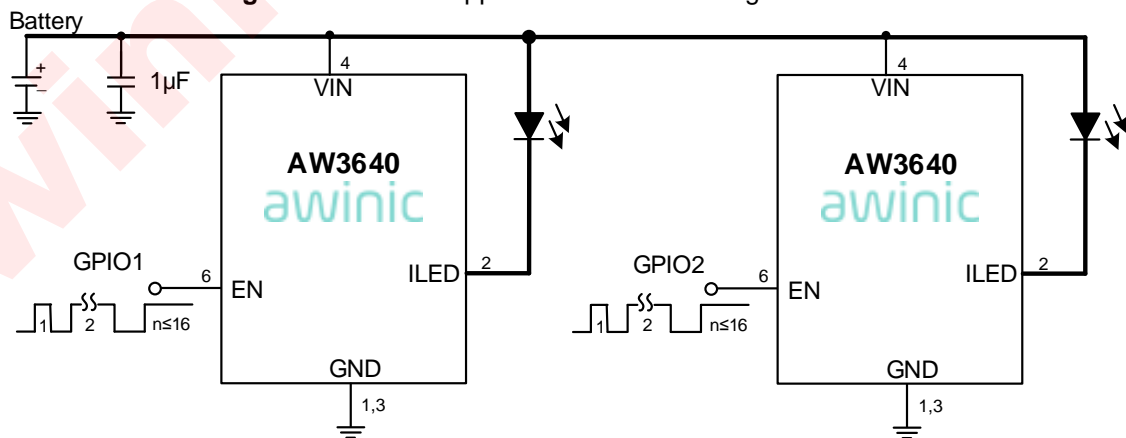

Figure 3 AW3640 Application Circuit for Dual LEDs

ABSOLUTE MAXIMUM RATINGS^(NOTE1)

PARAMETERS		Range	Unit
VIN, ILED		-0.3 to 6	V
EN		-0.3 to (VIN+0.3)	V
Max Junction Temperature T _{JMAX}		125	°C
Storage Temperature T _{STG}		-65 to 150	°C
Maximum lead temperature (soldering)		260	°C
Junction to Ambient Thermal Resistance θ_{JA}		148.2	°C/W
ESD, All Pins ^(NOTE2)	HBM	2000	V
	MM	200	V
	CDM	1000	V
Latch-Up JEDEC STANDARD NO.78B DECEMBER 2008		+IT: +300 -IT: -300	mA

RECOMMENDED OPERATING CONDITIONS

PARAMETERS	Range	Unit
V _{IN}	2.8 to 5.5	V
Junction temperature (T _J)	-40 to 125	°C
Ambient temperature (T _A)	-40 to 85	°C

NOTE1: Conditions out of those ranges listed in "absolute maximum ratings" may cause permanent damages to the device. In spite of the limits above, functional operation conditions of the device should within the ranges listed in "recommended operating conditions". Exposure to absolute-maximum-rated conditions for prolonged periods may affect device reliability.

NOTE2: The human body model is a 100pF capacitor discharged through a 1.5kΩ resistor into each pin. Test method: MIL-STD-883G Method 3015.7

ELECTRICAL CHARACTERISTICS

$V_{BAT}=3.8V$, $T_A=25^{\circ}C$ for typical values (unless otherwise noted)

Symbol	Description	Test Conditions	Min	Typ.	Max	Units
Power supply						
V_{IN}	Input operation voltage		2.8		5.5	V
$I_{SHUTDOWN}$	Current in Shutdown mode	EN=0		0.1	1	μA
I_Q	Quiescent Current in Active mode	EN=1, ILED floating		255		μA
Digital Logical Interface						
V_{IL}	Logic input low level				0.4	V
V_{IH}	Logic input high level		1.3			V
R_{EN}	Pull down resistor inside			100		k Ω
1-Wire Dimming Pulse Timing						
T_{LO}	EN pulse low time		0.5		500	μs
T_{HI}	EN pulse high time		0.5			μs
T_{SHDN}	Chip shutdown delay	Measure from EN falling edge to the chip entering shutdown mode	0.8		2.5	ms
LED Driver						
I_{LED}	Current accuracy	$I_{LED}=200mA$	170	200	230	mA
V_{DROP}	Dropout voltage	$I_{LED}=200mA$		65	100	mV

FUNCTIONAL BLOCK DIAGRAM

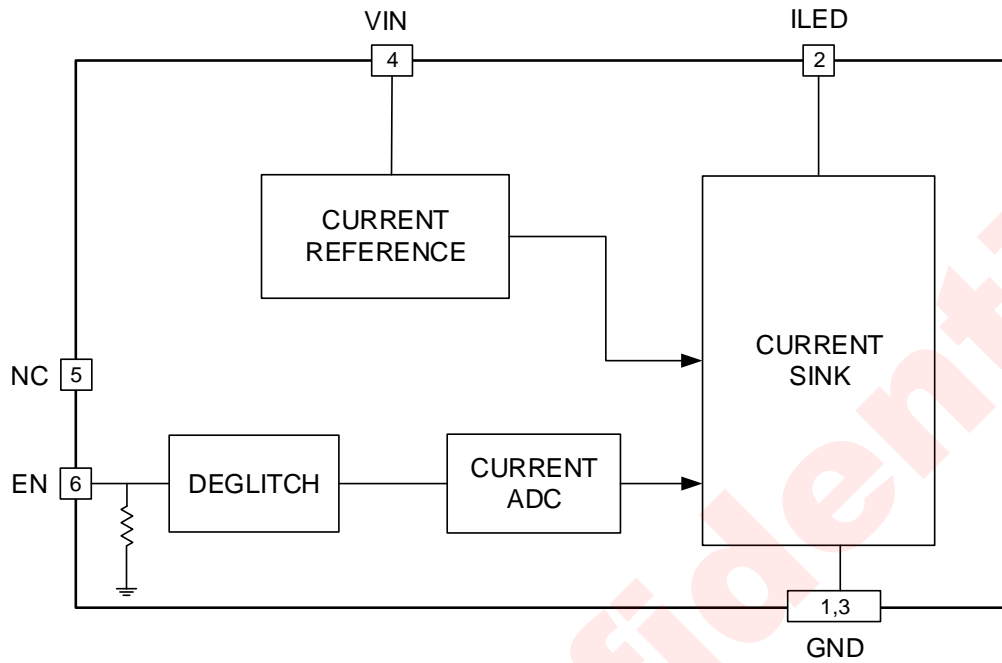

Figure 4 AW3640 Functional Block

TYPICAL CHARACTERISTICS

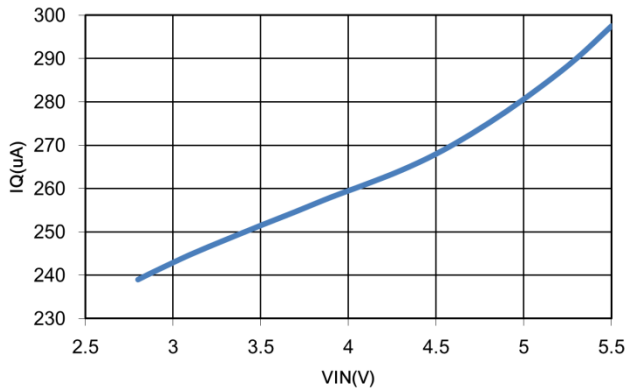

Figure 5 Quiescent Current vs. Input Voltage

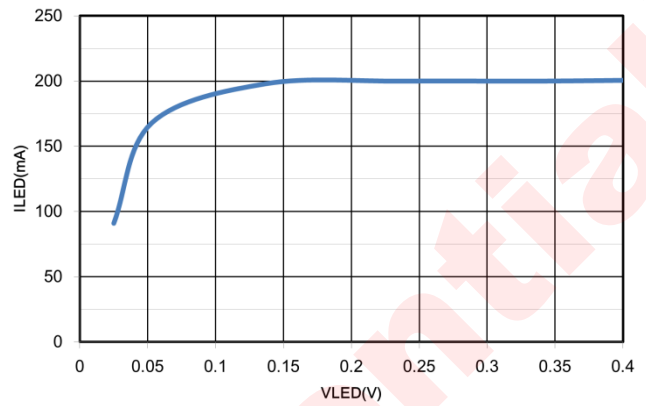

Figure 6 LED Current vs. ILED pin Voltage

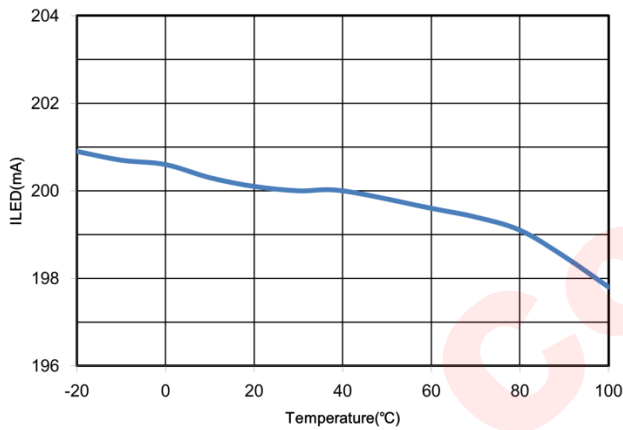

Figure 7 LED Current vs. Temperature

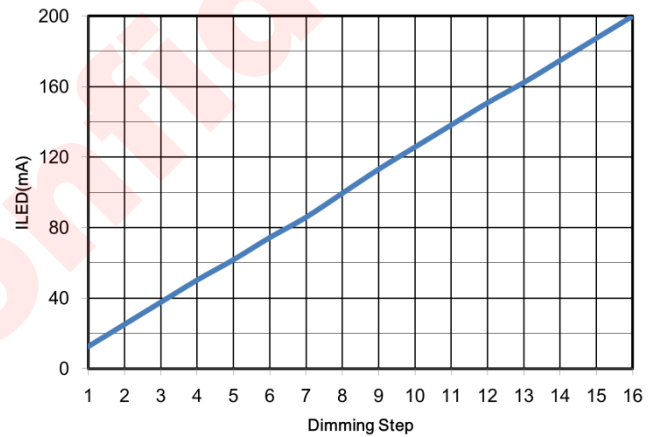

Figure 8 LED Current vs. 1-Wire Dimming Step

DETAILED DESCRIPTION

AW3640 is a low voltage-drop current sink LED driver, which supports both Torch and Flash modes. The current-regulation sink integrated in the chip make the LED current capable of keeping constant when input voltage, LED forward voltage or temperature changing. The LED current can be adjusted among 16 steps by sending 1-wire pulse into the EN pin, and the maximum value is 200mA.

ENABLE CONTROL

The voltage level at EN pin determines the operation state of the chip. When the EN pin is set to high, AW3640 operates in normal state. And the chip would enter shutdown mode if the EN pin is set to low for over 2.5ms, as a built-in shutdown delay circuit in AW3640. The shutdown current dissipated by AW3640 is less than $0.1 \mu A$.

GLITCH ELIMINATION

AW3640 built in deglitch circuit. The interference between signals inside the portable device is unavoidable, thus deglitch circuit is necessary at the EN pin. The deglitch circuit inside AW3640 is capable of eliminating the glitch which is narrower than 80ns, preventing the incorrect trigger at the EN pin effectively.

APPLICATION INFORMATION

1-WIRE PULSE DIMMING

AW3640 adopts the 1-wire pulse dimming to avoid the switch noise. A 4-bit DAC inside AW3640 allows counting the rising edge at the EN pin to set the LED current (refer to Figure 5 and Table 1). Figure 5 shows that the first high level hold time T_{ON} should be over $20\mu s$ to make sure the chip start up regularly, and meantime setting the LED current to the maximum value. Other EN pulse timing requirements include normal high level time T_{HI} should longer than $0.5\mu s$, and low level time T_{LO} should between $0.5\mu s$ and $500\mu s$.

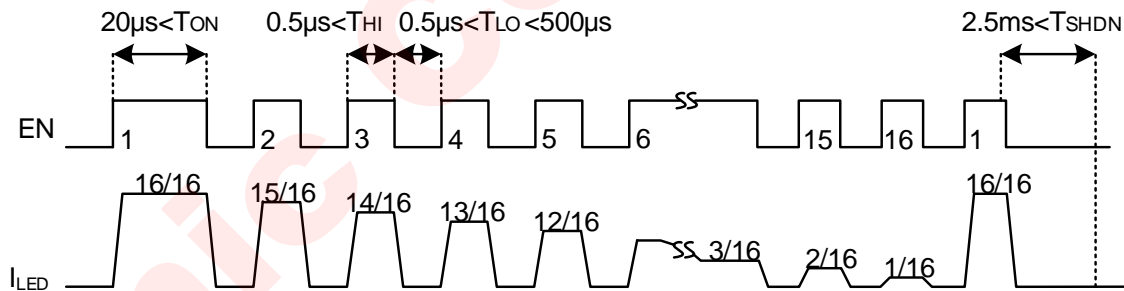

Figure 9 AW3640 1-wire dimming timing diagram

The LED current steps down along with the increasing EN pulse rising edge number as shown in table 1. After the current set process, the EN pin should set to high level.

Table 1 LED Current vs. EN Rising Edge Number

EN Rising Edge Number	LED Current (Ma)	EN Rising Edge Number	LED Current (Ma)
1	200	9	100
2	187.5	10	87.5
3	175	11	75
4	162.5	12	62.5
5	150	13	50
6	137.5	14	37.5
7	125	15	25
8	112.5	16	12.5

EFFICIENCY

AW3640 is a low voltage-drop current sink LED driver, its operation efficiency can be approximately calculated as below.

$$\eta = \frac{P_{OUT}}{P_{IN}} = \frac{V_F \times I_{OUT}}{V_{IN} \times I_{IN}} \approx \frac{V_F \times I_{OUT}}{V_{IN} \times I_{OUT}} = \frac{V_F}{V_{IN}}$$

V_F in the formula represents the forward voltage of LED. If V_{IN} is 3.6V, V_F is 3.4V, the chip efficiency is about 94%.

PCB LAYOUT CONSIDERATION

To make fully use of the performance of AW3640, the guidelines below should be followed.

- 1、 All the peripherals should be placed as close to the device as possible. Place the input capacitor C_{IN} on the top layer (same layer as the AW3640) and close to V_{IN} (pin4).
- 2、 Route the power line (shown in Figure 2) as widely and shortly as possible to reduce parasitic impedance.
- 3、 To optimize the heat dissipation performance, the GND pins (pin1 & 3) should be connected to the PCB ground plane using as many vias as possible.

TAPE AND REEL INFORMATION

CARRIER TAPE

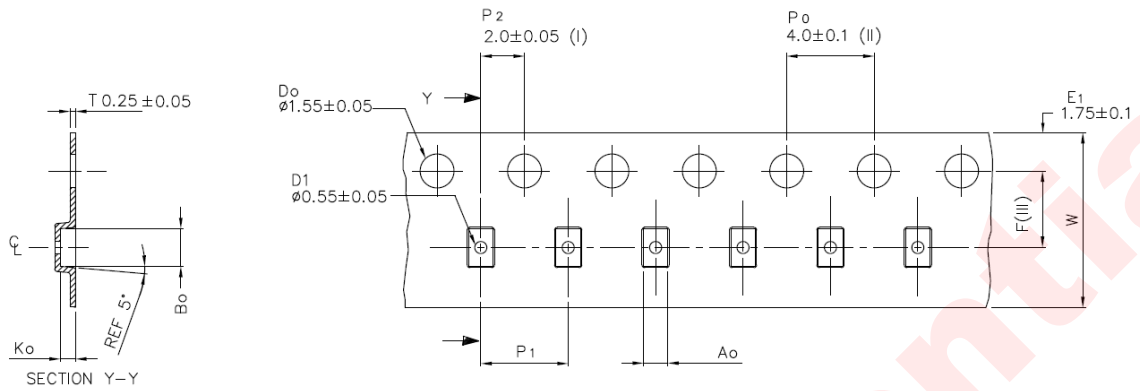

Ao	1.12	+/-0.05
Bo	1.72	+/-0.05
Ko	0.70	+/-0.05
F	3.50	+/-0.05
P1	4.00	+/-0.1
W	8.00	+0.3/-0.1

- (I) Measured from centreline of sprocket hole to centreline of pocket.
- (II) Cumulative tolerance of 10 sprocket holes is ± 0.20 .
- (III) Measured from centreline of sprocket hole to centreline of pocket.
- (IV) Other material available.

ALL DIMENSIONS IN MILLIMETRES UNLESS OTHERWISE STATED.

PIN1

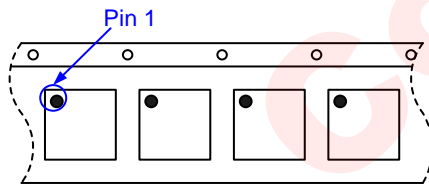

User Direction of Feed

REEL

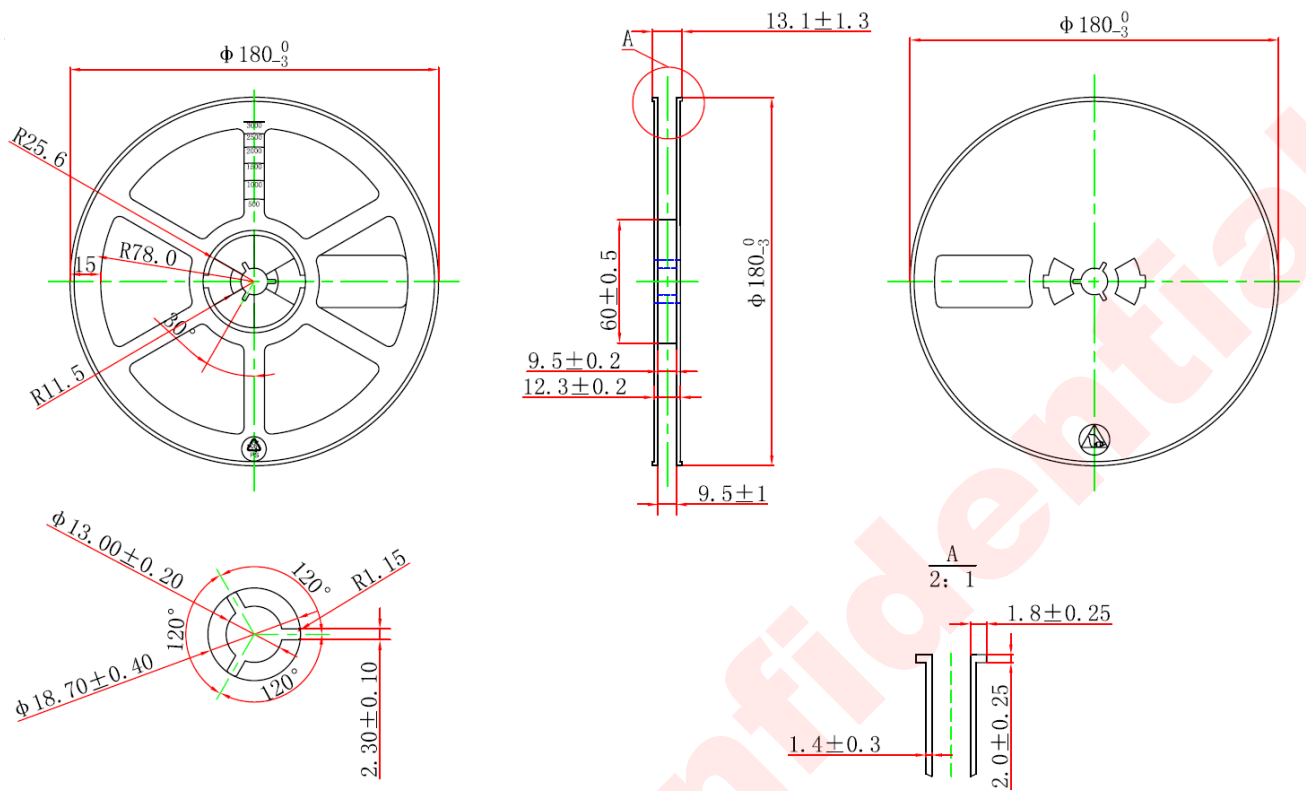

NOTE:

- 1、 ALL DIMS IN mm;
- 2、 General Tolerance ± 0.25 mm.

PACKAGE INFORMATION

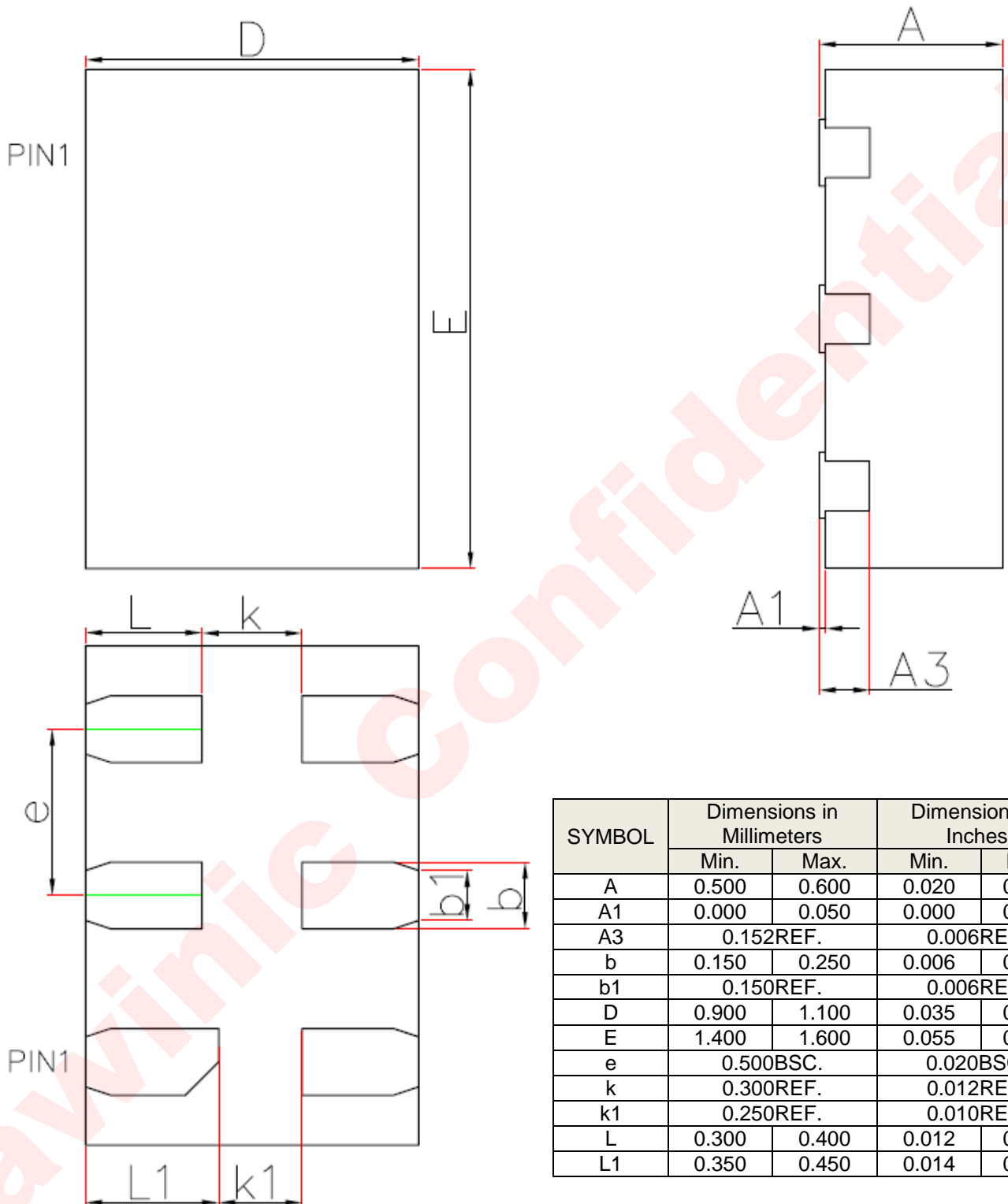

SYMBOL	Dimensions in Millimeters		Dimensions in Inches	
	Min.	Max.	Min.	Max.
A	0.500	0.600	0.020	0.024
A1	0.000	0.050	0.000	0.002
A3	0.152REF.		0.006REF.	
b	0.150	0.250	0.006	0.010
b1	0.150REF.		0.006REF.	
D	0.900	1.100	0.035	0.043
E	1.400	1.600	0.055	0.063
e	0.500BSC.		0.020BSC.	
k	0.300REF.		0.012REF.	
k1	0.250REF.		0.010REF.	
L	0.300	0.400	0.012	0.016
L1	0.350	0.450	0.014	0.018

LAND PATTERN EXAMPLE

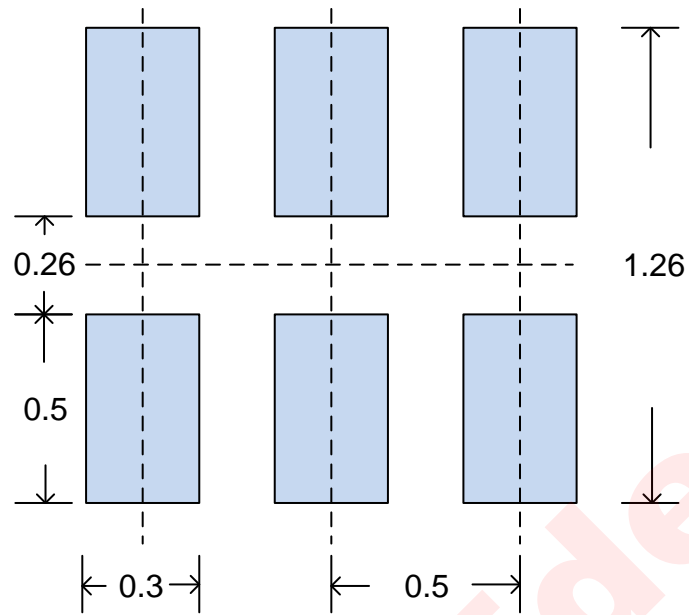

NOTE: Dimensions are in millimeters.

REFLOW

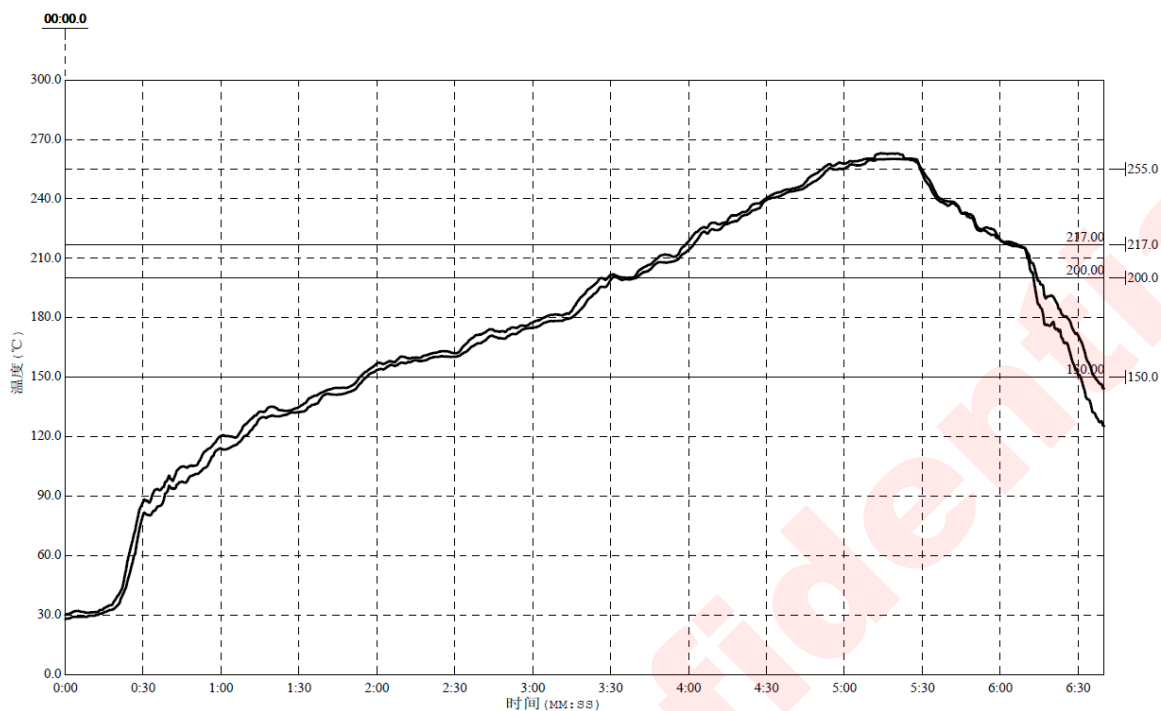

Figure 3 Package Reflow Oven Thermal Profile

Reflow Note	Spec
Average ramp-up rate (217°C to Peak)	Max. 3°C/sec
Time of Preheat temp.(from 150°C to 200°C)	60-120sec
Time to be maintained above 217°C	60-150sec
Peak Temperature	250°C-260°C
Time within 5°C of actual peak temp	20-40sec.
Ramp-down rate	Max. 6°C/sec
Time from 25°C to peak temp	Max. 8min.

REVISION HISTORY

Vision	Date	Change Record
V0.9	July 2016	Datasheet V0.9 Released
V1.0	October 2016	Datasheet V1.0 Released
V1.1	January 2017	1. Added Tape and Reel information; 2. Added RoHS and MSL statements. 3. Added Land pattern example.
V1.2	February 2018	1. Updated Ordering Information table; 2. Deleted Page1 Chinese content.
V1.3	September 2018	1. Updated MSL level.

awinic Confidential

DISCLAIMER

Information in this document is believed to be accurate and reliable. However, Shanghai AWINIC Technology Co., Ltd (AWINIC Technology) does not give any representations or warranties, expressed or implied, as to the accuracy or completeness of such information and shall have no liability for the consequences of use of such information.

AWINIC Technology reserves the right to make changes to information published in this document, including without limitation specifications and product descriptions, at any time and without notice. Customers shall obtain the latest relevant information before placing orders and shall verify that such information is current and complete. This document supersedes and replaces all information supplied prior to the publication hereof.

AWINIC Technology products are not designed, authorized or warranted to be suitable for use in medical, military, aircraft, space or life support equipment, nor in applications where failure or malfunction of an AWINIC Technology product can reasonably be expected to result in personal injury, death or severe property or environmental damage. AWINIC Technology accepts no liability for inclusion and/or use of AWINIC Technology products in such equipment or applications and therefore such inclusion and/or use is at the customer's own risk.

Applications that are described herein for any of these products are for illustrative purposes only. AWINIC Technology makes no representation or warranty that such applications will be suitable for the specified use without further testing or modification.

All products are sold subject to the general terms and conditions of commercial sale supplied at the time of order acknowledgement.

Nothing in this document may be interpreted or construed as an offer to sell products that is open for acceptance or the grant, conveyance or implication of any license under any copyrights, patents or other industrial or intellectual property rights.

Reproduction of AWINIC information in AWINIC data books or data sheets is permissible only if reproduction is without alteration and is accompanied by all associated warranties, conditions, limitations, and notices. AWINIC is not responsible or liable for such altered documentation. Information of third parties may be subject to additional restrictions.

Resale of AWINIC components or services with statements different from or beyond the parameters stated by AWINIC for that component or service voids all express and any implied warranties for the associated AWINIC component or service and is an unfair and deceptive business practice. AWINIC is not responsible or liable for any such statements.