

AWB51D9 Data Sheet

1.2 GHz CATV Push-pull Amplifier MMIC

1. Product Overview

1.1 Features

- 50 ~ 1200 MHz Bandwidth
- 21.5 dB Gain at 500 MHz
- CSO : 65 dBc, CTB : 62 dBc
@ Pout = 103 dBμV flat for NTSC 79 channels + QAM256 75 channels, -6 dB offset
- Robust under Hard Operating Conditions
- +8 V, 370 mA Supply

1.2 Applications

- CATV Line Amplifiers
- HFC Nodes
- Head End Equipment

1.3 Package Profile & RoHS Compliance

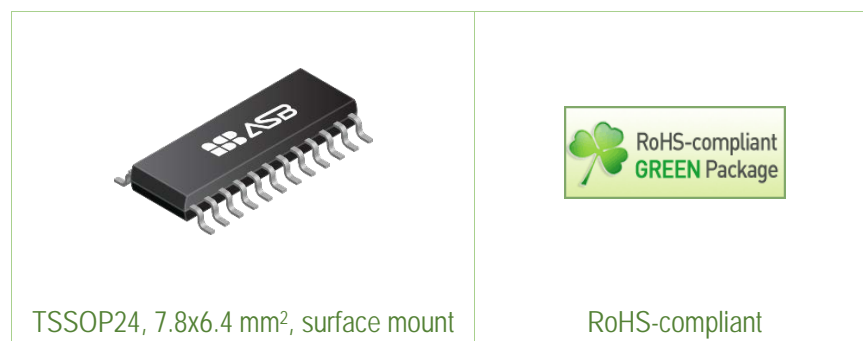

2. Summary on Product Performances

2.1 Typical Performance

Supply voltage = +8 V, $T_A = +25\text{ }^\circ\text{C}$, $Z_0 = 75\ \Omega$.

Parameter	Typical				Unit
Frequency	50	500	1000	1200	MHz
Gain	21.8	21.5	21.9	22.2	dB
S11	-19	-15	-22	-14.5	dB
S22	-21	-17	-22	-16	dB
Noise Figure	2.4	2.6	2.8	2.4	dB
CSO ¹⁾	60				dBc
CTB ¹⁾	63				dBc
Current	370				mA
Device Voltage	+8				V

1) CSO & CTB measured at $P_{out} = 108\text{ dB}\mu\text{V}$ flat for Cenelec-42 channels.

2.2 Product Specification

Supply voltage = +8 V, $T_A = +25\text{ }^\circ\text{C}$, $Z_0 = 75\ \Omega$.

Parameter	Min	Typ	Max	Unit
Frequency		500		MHz
Gain		21.5		dB
S11		-15		dB
S22		-17		dB
Noise Figure		2.6		dB
Current		370		mA
Device Voltage		+8		V

2.3 Pin Configuration

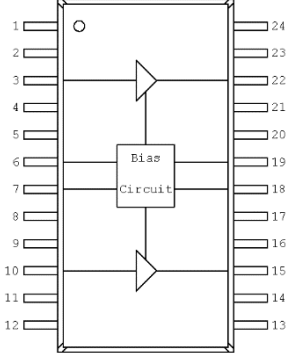
Pin	Description	Simplified Outline
3, 10	RF_IN	
6, 7	Current Adjustable	
18, 19	V _{CG} Adjustable	
15, 22	RF_OUT	
Others	NC or GND	

Note: Backside metal paddle is RF and DC ground.

2.4 Absolute Maximum Ratings

Parameters	Max. Ratings
Operation Case Temperature	-40 to +85 °C
Storage Temperature	-40 to +150 °C
Device Voltage	+10 V
Maximum Current	470 mA
Operation Junction Temperature	+160 °C
Input RF Power (CW, 75 Ω matched)	+24 dBm

2.5 Thermal Resistance

Symbol	Description	Typ	Unit
R _{th}	Thermal resistance from junction to lead	9	°C/W

2.6 ESD Classification & Moisture Sensitivity Level

ESD Classification

HBM	Class 1B	Voltage Level: 750 V
MM	Class A	Voltage Level: 100 V

CAUTION: Gallium Arsenide Integrated Circuits are sensitive to electrostatic discharge (ESD) and can be damaged by static electricity. Proper ESD control techniques should be used when handling these devices.

Moisture Sensitivity Level

MSL 3 at 260 °C reflow

3. Application: 50 ~ 1200 MHz (75 Ω Push-pull, $V_{supply} = +8 V$)

3.1 Application Circuit & Evaluation Board

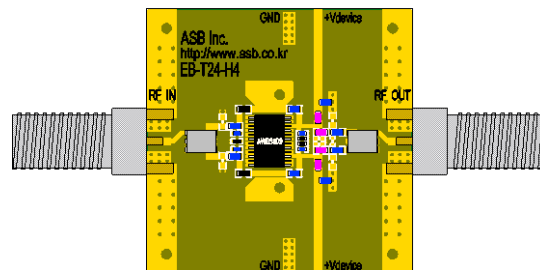
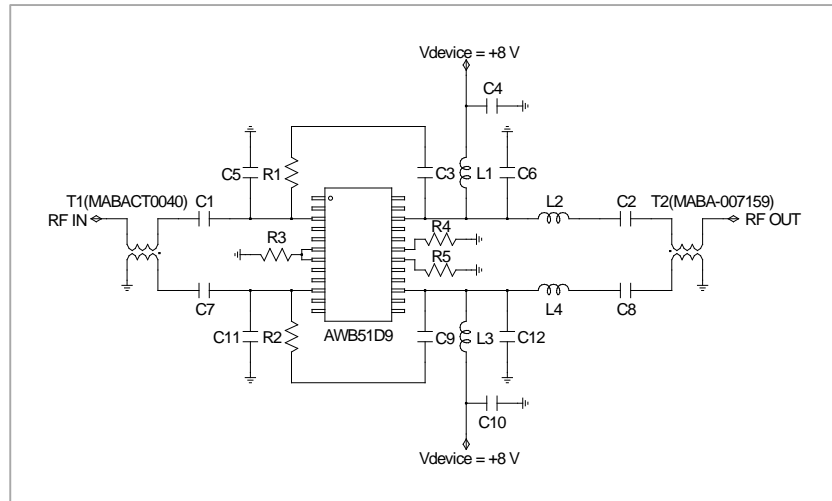

PCB Information	
Material	FR4
Thickness (mm)	0.8
Size (mm)	40x40
EB No.	EB-T24-H4

Bill of Material

Symbol	Value	Size	Description	Manufacturer
AWB51D9	-	-	MMIC Amplifier	ASB
C1, C2, C7, C8	1 μ F	0603	DC blocking capacitor	Murata
C3, C9	1 μ F	0603	Feedback capacitor	Murata
C4, C10	10 μ F	0805	Decoupling capacitor	Murata
C5, C11	1.8 pF	0603	Matching capacitor	Murata
C6, C12	2.2 pF	0402	Matching capacitor	Murata
L1, L3	1 μ H	1206	RF choke inductor	Murata
L2, L4	2.2 nH	0603	Matching inductor	Murata
R1, R2	620 Ω	0603	Feedback resistor	Samsung
R3	0 Ω	0402	Current adjust resistor	Samsung
R4, R5	2 k Ω	0402	V_{CG} adjust resistor	Samsung
T1, T2	1:1	-	Transformer balun	MACOM

3.2 Performance Table

Supply voltage = +8 V, $T_A = +25\text{ }^\circ\text{C}$, $Z_0 = 75\ \Omega$.

Parameter	Typical			Unit
Frequency	50	500	1200	MHz
Gain	21.8	21.5	22.2	dB
S11	-19	-15	-14.5	dB
S22	-21	-17	-16	dB
Noise Figure	2.4	2.6	2.4	dB
CSO ¹⁾	60			dBc
CTB ¹⁾	63			dBc
Current	370			mA
Device Voltage	+8			V

1) CSO & CTB measured at $P_{out} = 108\text{ dB}\mu\text{V}$ flat for Cenelec-42 channels.

3.3 Plot of S-parameter & Stability Factor

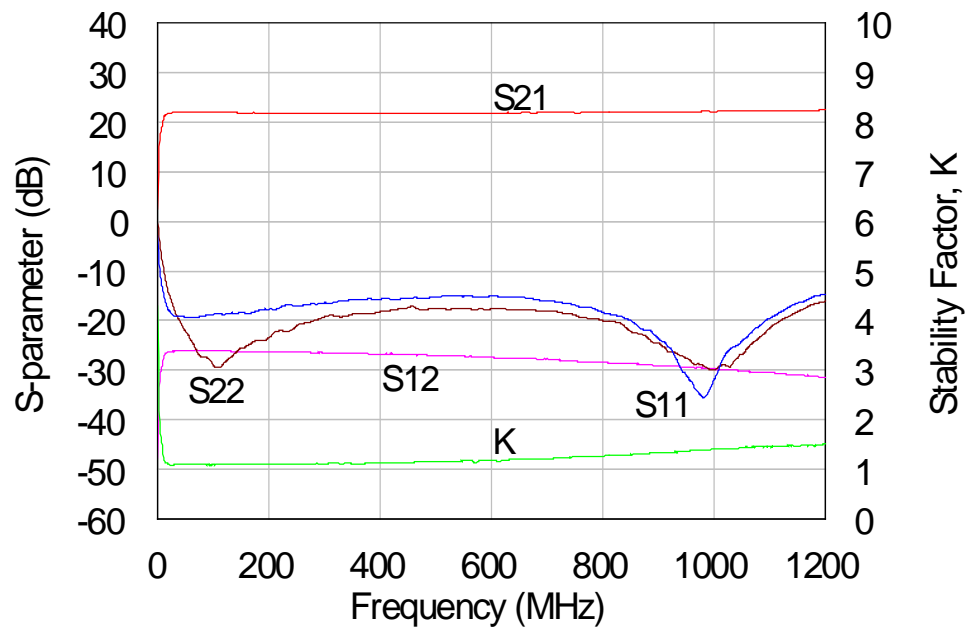

4. Application: 50 ~ 1000 MHz (75 Ω Push-pull, $V_{supply} = +8 V$)

4.1 Application Circuit & Evaluation Board

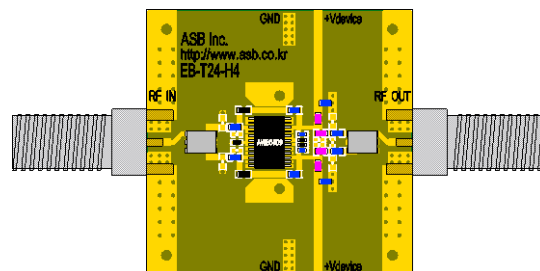
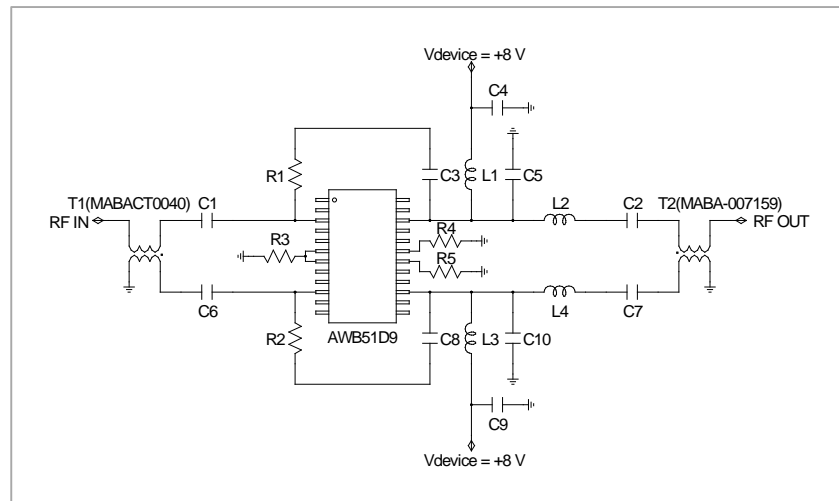

PCB Information

Material	FR4
Thickness (mm)	0.8
Size (mm)	40x40
EB No.	EB-T24-H4

Bill of Material

Symbol	Value	Size	Description	Manufacturer
AWB51D9	-	-	MMIC Amplifier	ASB
C1, C2, C6, C7	1 μ F	0603	DC blocking capacitor	Murata
C3, C8	1 μ F	0603	Feedback capacitor	Murata
C4, C9	10 μ F	0805	Decoupling capacitor	Murata
C5, C10	1.5 pF	0603	Matching capacitor	Murata
L1, L3	1 μ H	1206	RF choke inductor	Murata
L2, L4	2.2 nH	0603	Matching inductor	Murata
R1, R2	620 Ω	0603	Feedback resistor	Samsung
R3	0 Ω	0402	Current adjust resistor	Samsung
R4, R5	2 k Ω	0402	V _{CG} adjust resistor	Samsung
T1, T2	1:1	-	Transformer balun	MACOM

4.2 Performance Table

Supply voltage = +8 V, T_A = +25 °C, Z_O = 75 Ω.

Parameter	Typical			Unit
Frequency	50	500	1000	MHz
Gain	21.8	21.6	22.0	dB
S11	-19	-18	-18	dB
S22	-21	-17	-16	dB
Noise Figure	2.4	2.6	3.0	dB
CSO ¹⁾	65			dBc
CTB ¹⁾	62			dBc
Current	370			mA
Device Voltage	+8			V

1) CSO & CTB measured at P_{out} = 103 dBμV flat for NTSC 79 channels + QAM 256 75 channels, -6 dB offset.

4.3 Plot of S-parameter & Stability Factor

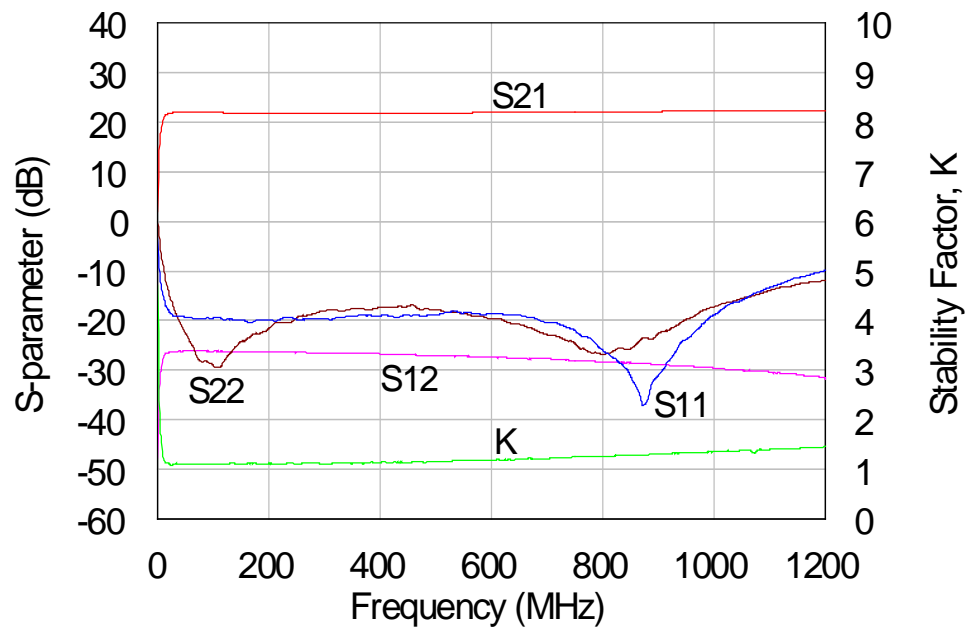

5. Package Outline (TSSOP24)

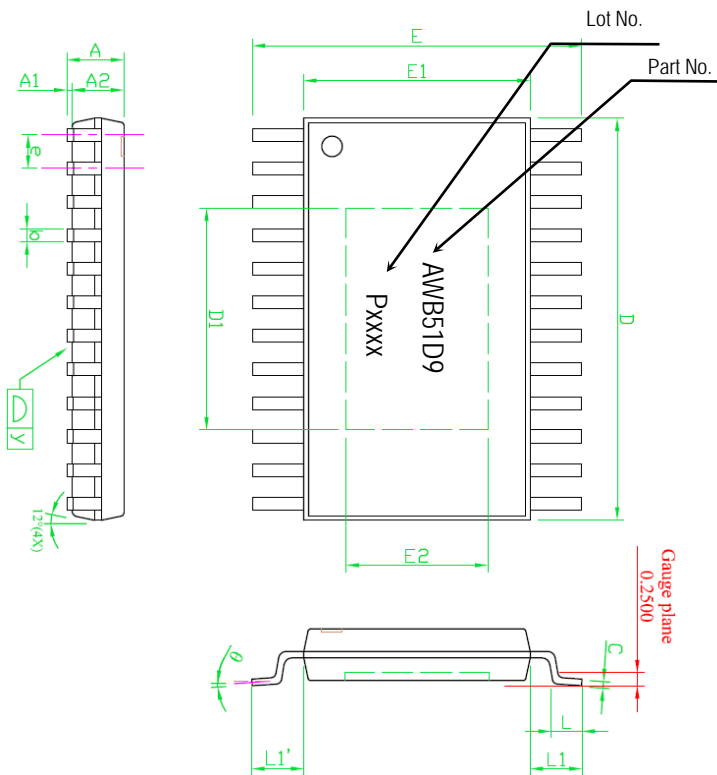

Symbols	Dimensions (In mm)		
	MIN	NOM	MAX
A	---	---	1.15
A1	0.00	----	0.10
A2	0.80	1.00	1.05
b	0.19	---	0.30
C	0.09	---	0.20
D	7.70	7.80	7.90
D1	4.086	4.286	4.486
E	6.20	6.40	6.60
E1	4.30	4.40	4.50
E2	2.55	2.75	2.95
e	---	0.65	---
L	0.45	0.60	0.75
y	---	---	0.10
θ	0°	---	8°
L1-L1'	---	---	0.12
L1		1.00REF	

6. Surface Mount Recommendation (In mm)

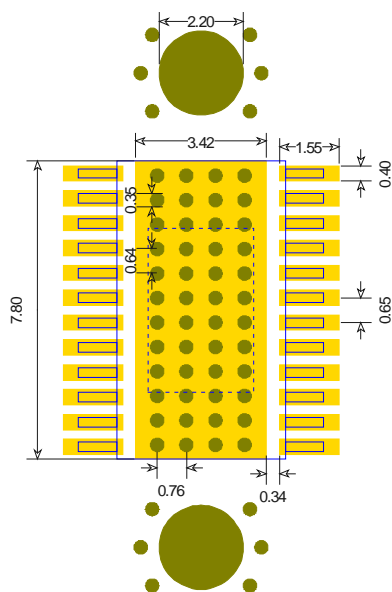

NOTE

1. Add as much copper as possible to inner and outer layers near the part to ensure optimal thermal performance.
2. To ensure reliable operation, device ground paddle-to-ground pad soldering is critical.
3. Add mounting screws near the part to fasten the board to a heat sinker. Ensure that the ground & thermal via region contacts the heat sinker.
4. A proper heat dissipation path underneath the area of the PCB for the mounted device is strictly required for proper thermal operation. Damage to the device can result from inappropriate heat dissipation.

7. Recommended Soldering Reflow Profile

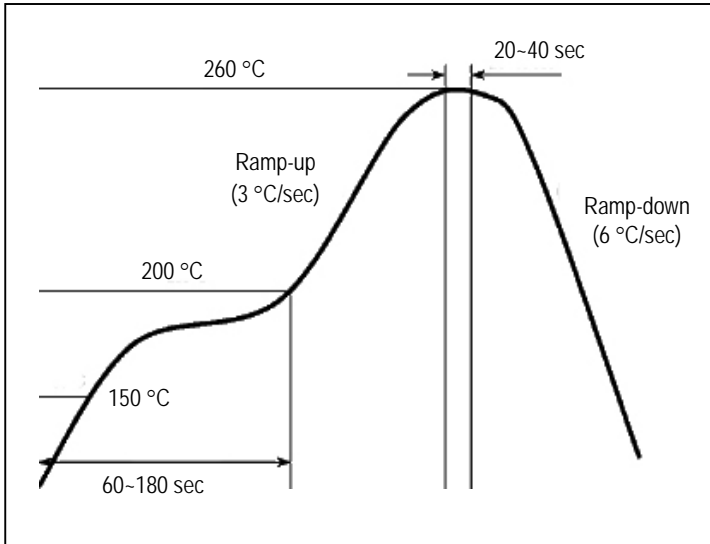

(End of Datasheet)